

REV.	ECR/ECN No.	DESCRIPTION	DRAWN/DATE	CHECKED/DATE	APPROVED/DATE
D	ECN2021069	UPDATE FRAME	Abner 2021-07-08	Staven 2021-07-08	Sam 2021-07-08
E	ECN2021120	Add change record	Abner 2021-11-30	Staven 2021-11-30	Sam 2021-11-30

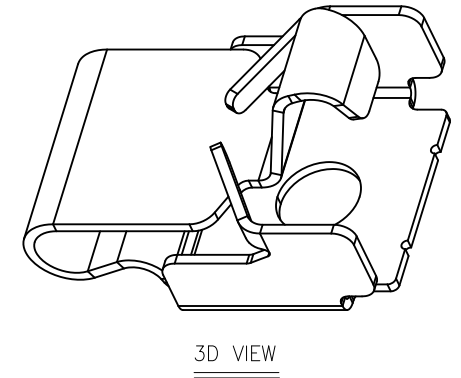
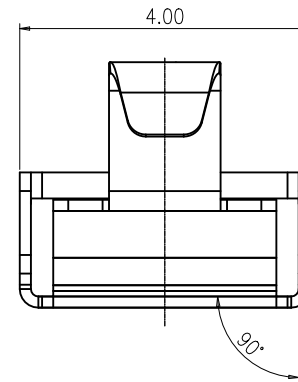

NOTES:

1. MATERIAL:SUS 304 T=0.15mm;
2. FINISH: Au 2u" SURFACE PLATING OVER CONTACT AREAS,
Au 2u" SURFACE PLATING OVER SOLDER AREAS,
Ni 40-80u" UNDER PLATING OVER ALL.
3. ALL MATERIAL MUST BE COMPLY WITH RoHS2.0.

UNLESS OTHERWISE SPECIFIED TOLERANCES			ANGLE OF PROJECTION		Amphenol AORORA	
X.	±0.30	X. *	± 2'		Amphenol Aorora Technology (Huizhou) Co.,Ltd	
X.X	±0.20	X.X *	± 1'			
X.XX	±0.10	X.XX *	± 0.2'	DOC TYP	Customer Drw	
X.XXX	±0.05	X.XXX *	± 0.1'	DRAWN DATE	Abner 2021-11-30	TITLE: H3.30mm Spring
LINEAR DIMS			ANGLES DIMS	DESIGN DATE	Abner 2021-11-30	SIZE PART NUMBER: A4 Z003-007L1-11001
DWG NO.:	A-S0055		CHECKED DATE		Staven 2021-11-30	REV. E
MATERIAL	SEE NOTES		APPROVED DATE		Sam 2021-11-30	SCALE 1:1 UNIT : mm SHEET 1 OF 1
FINISHED	SEE NOTES					

This document is the property of and embodies CONFIDENTIAL and PROPRIETARY information of AOR. No part of the information shown on this document may be used in any way or disclosed to others without the written consent of AOR. © 2019 AOR



