

1

2

3

4

REV.	ECR/ECN No.	DESCRIPTION	DRAWN/DATE	CHECKED/DATE	APPROVED/DATE
F		UPDATE FRAME	Staven 2020-11-13	Staven 2020-11-13	Biao 2020-11-13
G	ECN2022112	UPDATE CPK SYMBOLS	Abner 2022-07-20	Staven 2022-07-20	Sam 2022-07-20

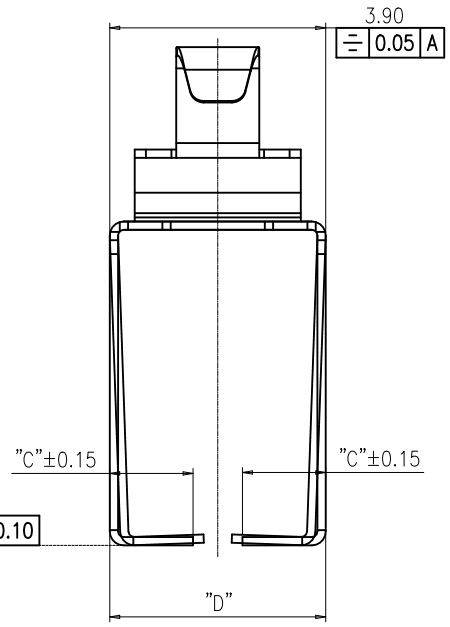
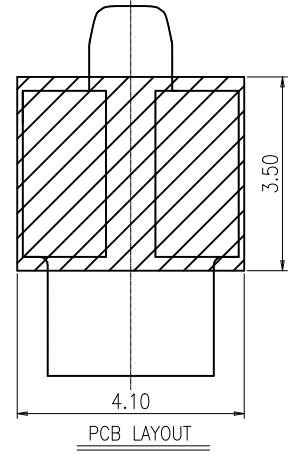
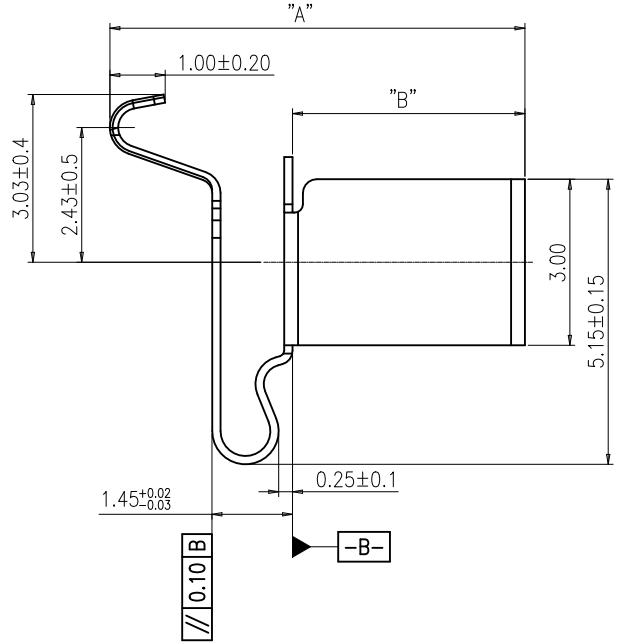
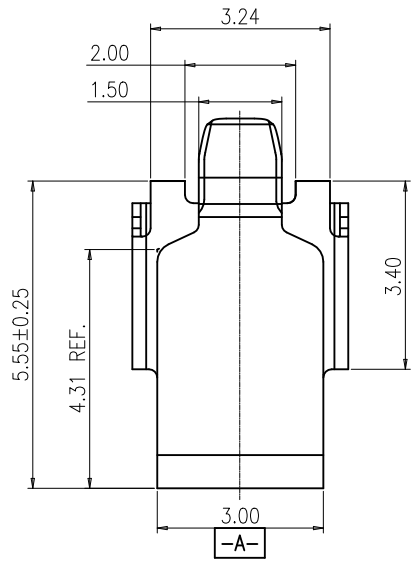

- NOTES:
- 1、 MATERIAL: SUS 304-H T=0.15mm;
  - 2、 ALLOW BURR 0.03mm Max.;
  - 3、 PLATING: Au 2u" SURFACE PLATING OVER CONTACT AREAS, Au 2u" SURFACE PLATING OVER SOLDER AREAS, Ni 40-120u" UNDER PLATING OVER ALL.
  - 4、 "▼" THE SYMBOL IS REPRESENTED AS CPK AND  $\bar{X}$ -R.

TABLE:

PART NUMBER	A	B	C	D
Z00D-4G7L1-11000	4.8 <sup>+0.3</sup> <sub>-0.05</sub>	1.5 <sup>+0.0</sup> <sub>-0.3</sub>	1.50	3.90 <sup>+0</sup> <sub>-0.20</sub>
Z007-4G7L1-11000	5.2 <sup>+0.3</sup> <sub>-0.05</sub>	1.9 <sup>+0.0</sup> <sub>-0.3</sub>	1.05	3.90 <sup>+0</sup> <sub>-0.20</sub>
Z00C-4G7L1-11000	7.5 <sup>+0.3</sup> <sub>-0.05</sub>	4.2 <sup>+0.0</sup> <sub>-0.3</sub>	1.50	3.90 <sup>+0</sup> <sub>-0.20</sub>
Z00F-4G7L1-11000	9.0 <sup>+0.3</sup> <sub>-0.05</sub>	5.7 <sup>+0.0</sup> <sub>-0.3</sub>	0.80	3.90 <sup>+0</sup> <sub>-0.5</sub>
Z00N-4G7L1-11000	6.3 <sup>+0.3</sup> <sub>-0.3</sub>	3.0±0.15	1.50	3.90±0.15
Z00E-4G7L1-11000	4.0 <sup>+0.3</sup> <sub>-0.3</sub>	0.7±0.15	1.50	3.90±0.15
Z00X-4G7L1-11000-E000	5.6 <sup>+0.3</sup> <sub>-0.3</sub>	2.3±0.15	1.50	3.90±0.15

UNLESS OTHERWISE SPECIFIED TOLERANCES		ANGLE OF PROJECTION		 Amphenol Aorora Technology (Huizhou) Co.,Ltd	
X.	±0.30	X. *	± 5'		
X.X	±0.25	X.X *	± 4'	DOC TYP Customer Drw	
X.XX	±0.20	X.XX *	± 3'		
X.XXX	±0.15	X.XXX *	± 2'	DRAWN DATE Abner 2022-07-20	
LINEAR DIMS		ANGLES DIMS			
DWG NO.:	A-S0198			TITLE: SPRING	
MATERIAL	SEE NOTES				
FINISHED	SEE NOTES			SIZE PART NUMBER: A4 SEE TABLE	
		APPROVED DATE Sam 2022-07-20		REV. G	
		CHECKED DATE Staven 2022-07-20		SCALE 1:1 UNIT : mm SHEET 1 OF 1	

This document is the property of and embodies CONFIDENTIAL and PROPRIETARY information of AOR. No part of the information shown on this document may be used in any way or disclosed to others without the written consent of AOR. © 2019 AOR

1

2

3

4

REV.	ECR/ECN No.	DESCRIPTION	DRAWN/DATE	CHECKED/DATE	APPROVED/DATE
A		NEW RELEASE	May 2016-04-11	Qi Han 2016-04-11	Hongkui Liu 2016-04-11
B	ECN2022112	UPDATE FRAME	Abner 2022-07-20	Staven 2022-07-20	Sam 2022-07-20

NOTES:

- MATERIAL:
  - CARRY TAPE:HIPS,T=0.40mm, COLOR:TRANSPARENT.
  - REEL:HIPS,BLUE.
  - SHIM:PET,CLEAR.
- PRIMARY PACKING:800PCS/REEL.
- SECONDARY PACKING:10 REELS/CARTON  
("TOTAL"=10\*800/CARTON).
- PEELING RESISTANCE: 0.1N~0.9N(10~90gf);  
PEELING ANGLE: 165°~180°;  
PEELING SPEED: 300mm/minutes.

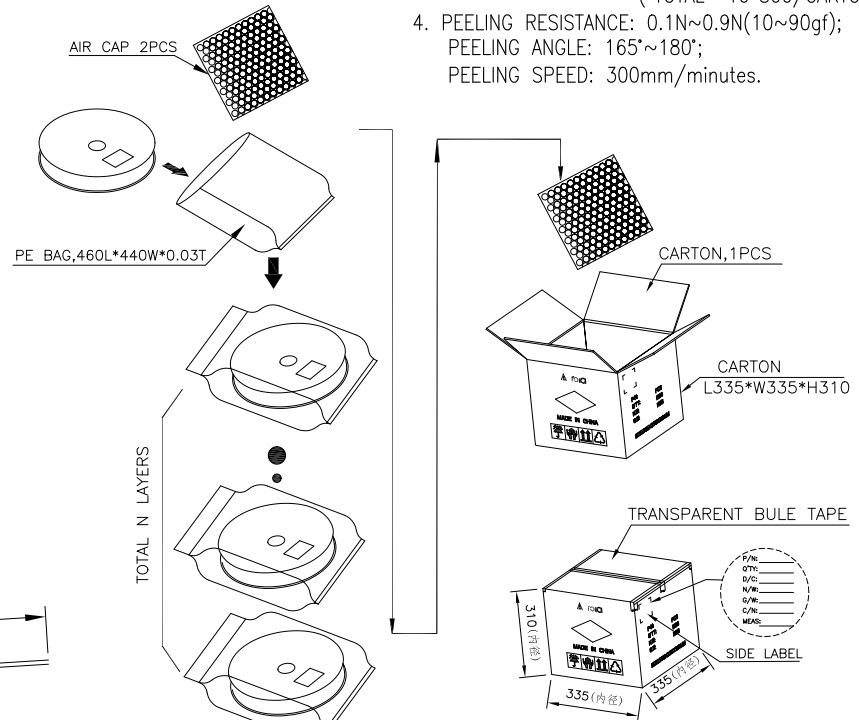
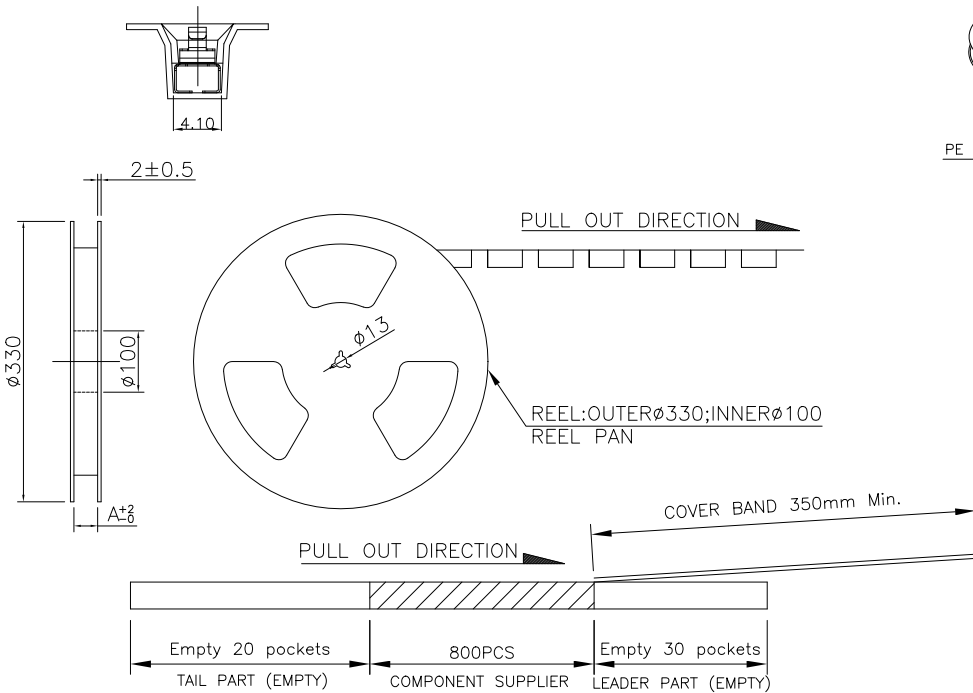
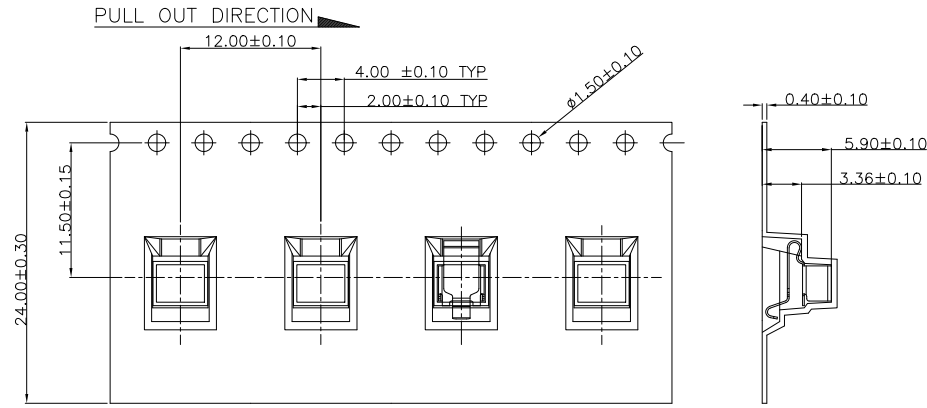

UNLESS OTHERWISE SPECIFIED TOLERANCES				ANGLE OF PROJECTION		Amphenol AORORA	
X.	±0.15	X. °	± 1'			Amphenol Aorora Technology (Huizhou) Co.,Ltd	
X.X	±0.16	X.X °	± 0.5'				
X.XX	±0.05	X.XX °	± 0.5'	DOC TYPE		TITLE:	
X.XXX	±0.03	X.XXX °	± 1'	PACKING DWG.		SPRING H5.6	
LINEAR DIMS		ANGLES DIMS		DRAWN	DATE	Abner	2022-07-20
DWG NO.: A-H0172				DESIGN	DATE	Abner	2022-07-20
MATERIAL		SEE NOTES		CHECKED	DATE	Staven	2022-07-20
FINISHED		SEE NOTES		APPROVED	DATE	Sam	2022-07-20
SIZE	PART NUMBER:		REV.				
A4	ZOOX-4G7L1-11000-E000		B				
SCALE	1:1	UNIT : mm	SHEET 1 OF 1				