

1

2

3

4

REV.	ECR/ECN No.	DESCRIPTION	DRAWN/DATE	CHECKED/DATE	APPROVED/DATE
F		UPDATE FRAME	Staven 2020-11-13	Staven 2020-11-13	Biao 2020-11-13
G	ECN2022112	UPDATE CPK SYMBOLS	Abner 2022-07-20	Staven 2022-07-20	Sam 2022-07-20

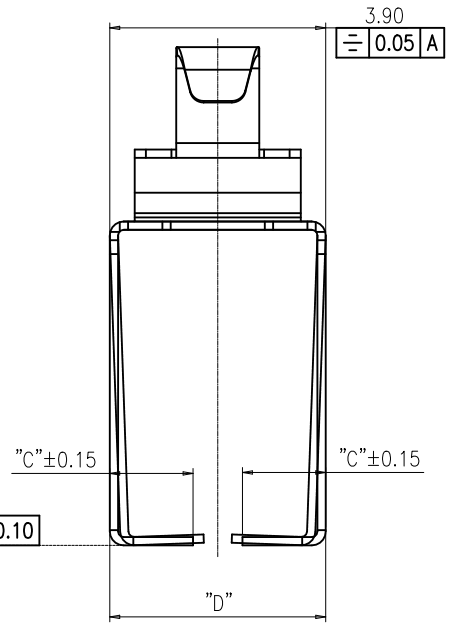
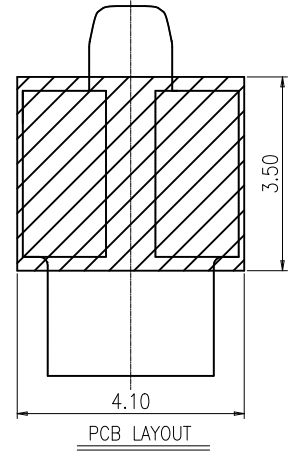
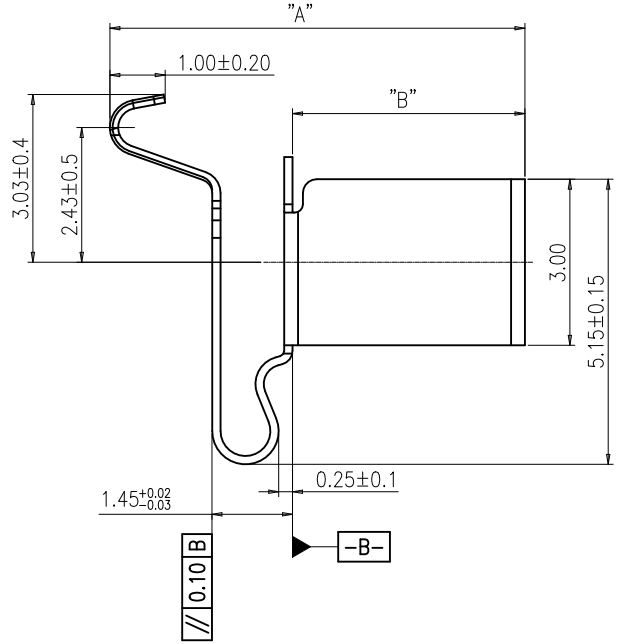
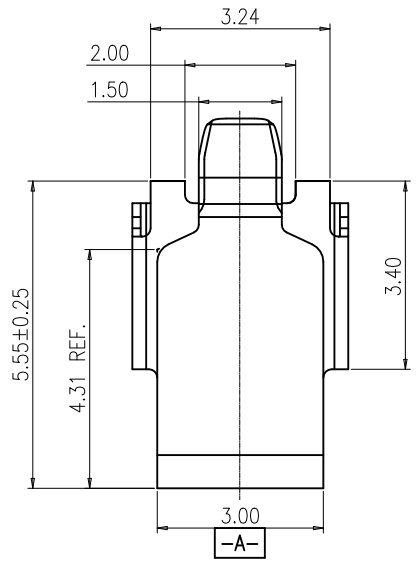

- NOTES:
- MATERIAL: SUS 304-H T=0.15mm;
 - ALLOW BURR 0.03mm Max.;
 - PLATING: Au 2u" SURFACE PLATING OVER CONTACT AREAS, Au 2u" SURFACE PLATING OVER SOLDER AREAS, Ni 40-120u" UNDER PLATING OVER ALL.
 - "▼" THE SYMBOL IS REPRESENTED AS CPK AND \bar{X} -R.

TABLE:

PART NUMBER	A	B	C	D
Z00D-4G7L1-11000	4.8 ^{+0.3} _{-0.05}	1.5 ^{+0.0} _{-0.3}	1.50	3.90 ⁺⁰ _{-0.20}
Z007-4G7L1-11000	5.2 ^{+0.3} _{-0.05}	1.9 ^{+0.0} _{-0.3}	1.05	3.90 ⁺⁰ _{-0.20}
Z00C-4G7L1-11000	7.5 ^{+0.3} _{-0.05}	4.2 ^{+0.0} _{-0.3}	1.50	3.90 ⁺⁰ _{-0.20}
Z00F-4G7L1-11000	9.0 ^{+0.3} _{-0.05}	5.7 ^{+0.0} _{-0.3}	0.80	3.90 ⁺⁰ _{-0.5}
Z00N-4G7L1-11000	6.3 ^{+0.3} _{-0.3}	3.0±0.15	1.50	3.90±0.15
Z00E-4G7L1-11000	4.0 ^{+0.3} _{-0.3}	0.7±0.15	1.50	3.90±0.15
Z00X-4G7L1-11000-E000	5.6 ^{+0.3} _{-0.3}	2.3±0.15	1.50	3.90±0.15

UNLESS OTHERWISE SPECIFIED TOLERANCES		ANGLE OF PROJECTION		 Amphenol Aorora Technology (Huizhou) Co.,Ltd	
X.	±0.30	X.	± 5'		
X.X	±0.25	X.X	± 4'	TITLE: SPRING	
X.XX	±0.20	X.XX	± 3'	Customer Drw	
X.XXX	±0.15	X.XXX	± 2'	DRAWN	Abner
LINEAR DIMS		ANGLES DIMS		DATE	2022-07-20
DWG NO.: A-S0198		DESIGN		DATE	Abner
MATERIAL		CHECKED		DATE	Staven
FINISHED		APPROVED		DATE	Sam
SEE NOTES		DATE		2022-07-20	2022-07-20
SEE NOTES		DATE		2022-07-20	2022-07-20

SIZE	PART NUMBER:		REV.
A4	SEE TABLE		G
SCALE	1:1	UNIT : mm	SHEET 1 OF 1



This document is the property of and embodies CONFIDENTIAL and PROPRIETARY information of AOR. No part of the information shown on this document may be used in any way or disclosed to others without the written consent of AOR. © 2019 AOR

1

2

3

4

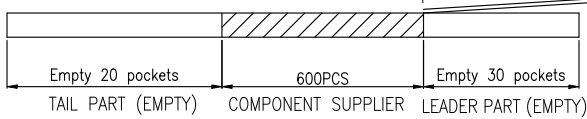
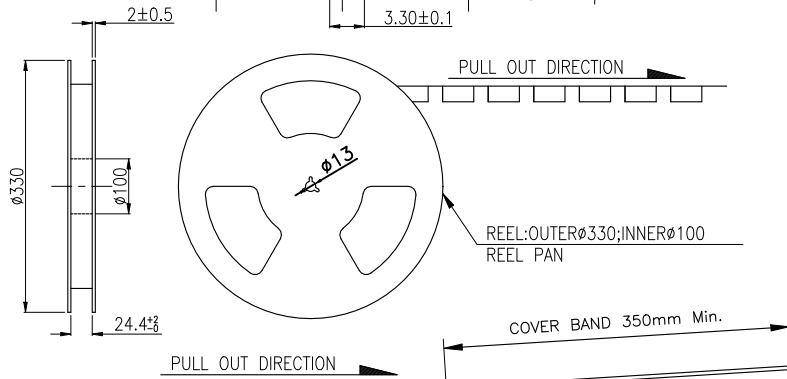
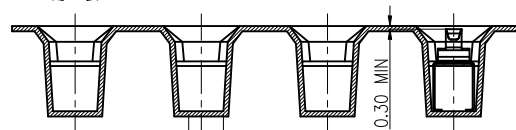
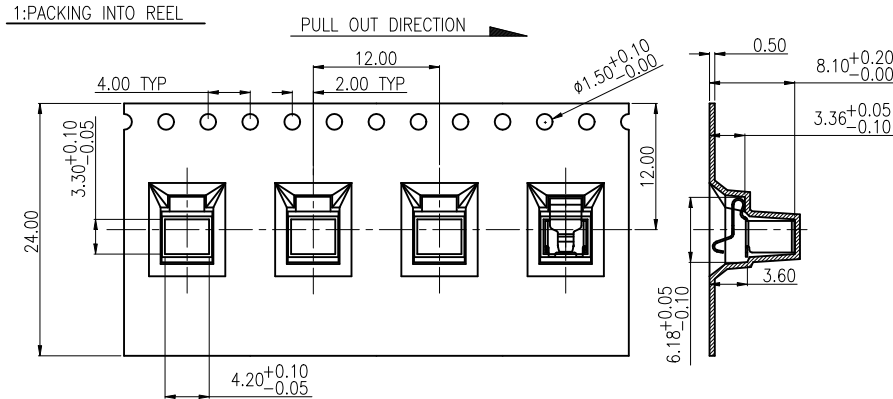

NOTES:

- MATERIAL:
 - CARRY TAPE:HIPS,T=0.50mm,COLOR:TRANSPARENT.
 - REEL:HIPS,BLUE.
 - SHIM:PE,CLEAR.
- PRIMARY PACKING:600PCS/REEL.
- SECONDARY PACKING:10 REELS/CARTON
("TOTAL"=10*600/CARTON).
- PEELING RESISTANCE: 0.1N~0.7N(10~70gf);
PEELING ANGLE: 165°~180°;
PEELING SPEED: 300mm/minutes.

REV.	ECR/ECN No.	DESCRIPTION	DRAWN/DATE	CHECKED/DATE	APPROVED/DATE
F	ECN20200073	Added H7.5 specification	Staven 2020-09-03	Staven 2020-09-03	Biao 2020-09-03

2:PACKING INTO OUTER BOX

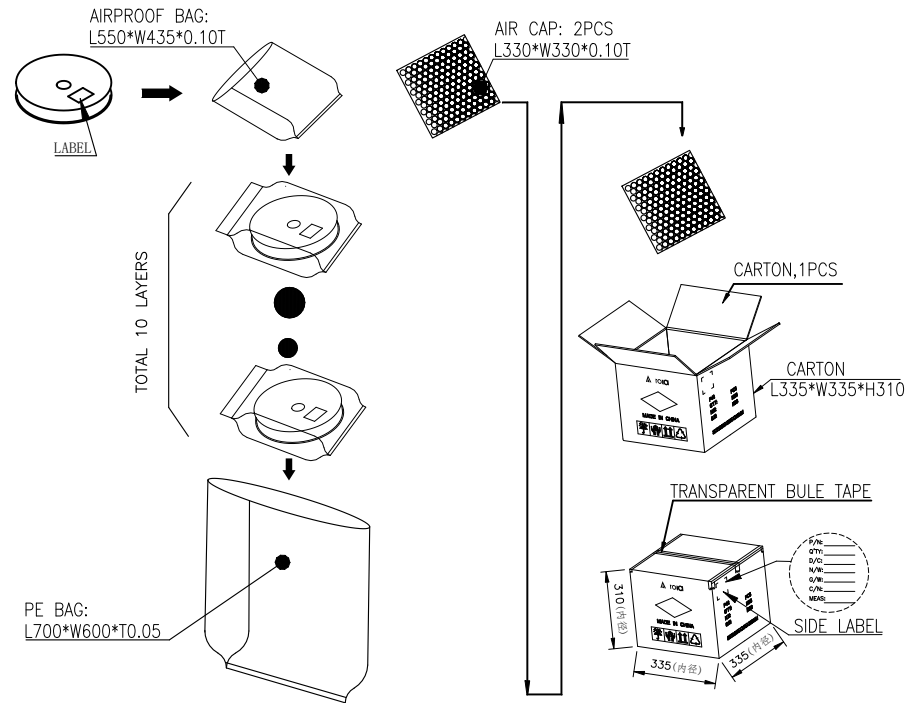

TABLE:

PART NO.	PCS/REEL	N REEL/BOX (TOL PCS)
Z00C-4G7L1-11000	600	10REEL/BOX (6000pcs)
Z01Q-4G7L1-11000-E000		
Z02D-4F7L1-11000-E000		

UNLESS OTHERWISE SPECIFIED TOLERANCES				ANGLE OF PROJECTION		Amphenol AORORA	
X.	±0.30	X. '	± 5'			Amphenol Aorora Technology (Huizhou) Co.,Ltd TITLE: H7.5 SPRING—PACKING	
X.X	±0.25	X.X '	± 4'				
X.XX	±0.20	X.XX '	± 3'	DOC TYPE		PACKING Drw	
X.XXX	±0.15	X.XXX '	± 2'	DRAWN	DATE	Staven	2020-09-03
LINEAR DIMS				ANGLES DIMS		DESIGN	DATE
DWG NO.:				A-H0099		Staven	2020-09-03
MATERIAL				SEE NOTES		CHECKED	DATE
FINISHED				SEE NOTES		Biao	2020-09-03
APPROVED				DATE		Biao	2020-09-03
SIZE	PART NUMBER:		REV.		TITLE:		
A4	SEE TABLE		F		H7.5 SPRING—PACKING		
SCALE	1:1	UNIT : mm	SHEET 1 OF 1				