

This is controlled document.  
 Hardcopy to be endorsed by authorized person.  
 Check with Issuing Officer or SAP system for latest update.

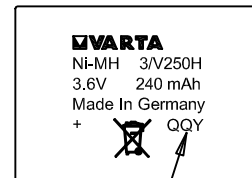

Quarterly code

Printing is on this side of the casing

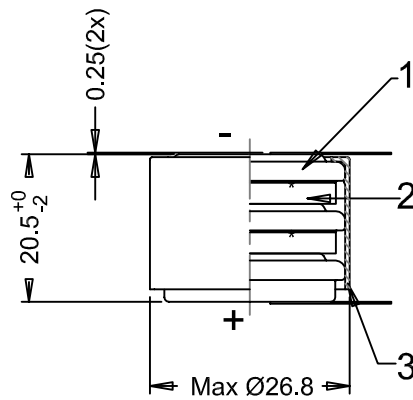
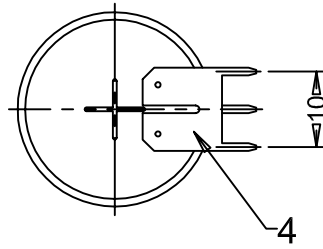
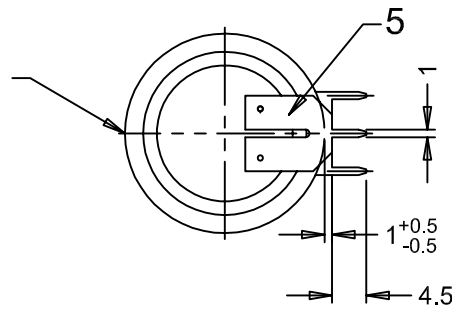

Note: No welding onto the groove

1	R332/08	Add cross wheeled bin	2008-10-11	Eka
No	AO No	Revisions	Date	Name

Projection:	Material:		Description:	
	Refer to part list no: 070838		3/V250H battery with snap-on plastic casing & solder tags	
Dimensions in mm	Prepared & Checked	Verified & Approved	Dwg. No:	070838
Tolerance: As specified	1997-08-21	A.P.ANG	VKB Order No:	55625 603 059
Scale: 1 : 1				4 0 1

Rights reserved to make technical changes, as a result of further development, without notice. This drawing is the property of VARTA Microbattery and must not be copied or disclosed to a third party without the written consent of VARTA Microbattery.

