

STRAIGHT PLUG CRIMP TYPE

CABLE 0.6/2.8 PACK.100

R142.077.702

Series : **BNC 75 HDTV**

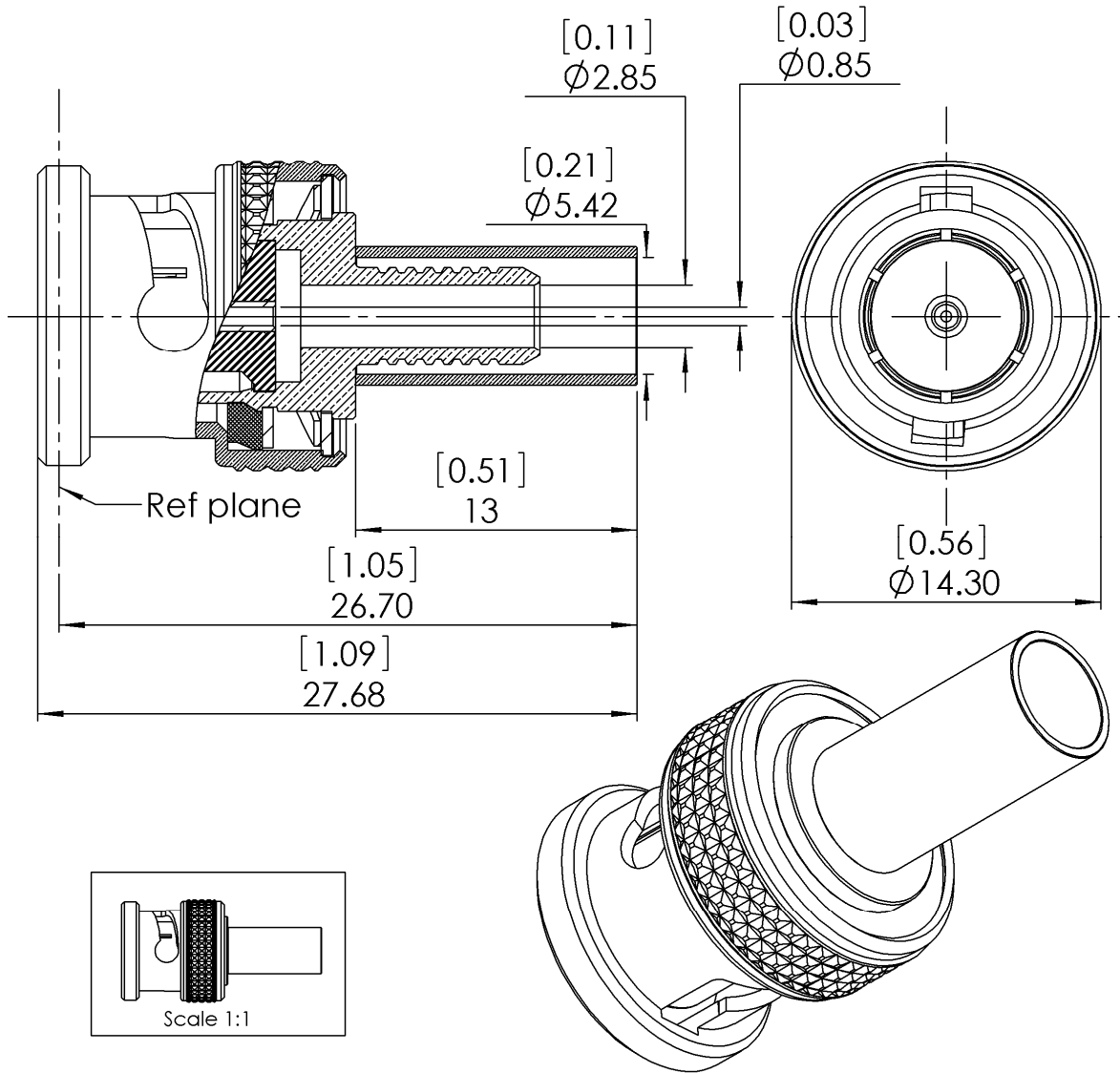

All dimensions are in mm.

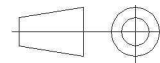

COMPONENTS	MATERIALS	PLATING (µm)
BODY	BRASS	NPGR
CENTER CONTACT	BRASS	NPGR
OUTER CONTACT	BRASS	NPGR
INSULATOR	PTFE	
GASKET	SILICONE RUBBER	
OTHERS PARTS	BRASS	BBR
-	-	-
-	-	-

Issue : 0843 B

In the effort to improve our products, we reserve the right to make changes judged to be necessary.



STRAIGHT PLUG CRIMP TYPE

R142.077.702

CABLE 0.6/2.8 PACK.100

Series : **BNC 75 HDTV**

PACKAGING

Standard	Unit	Other
100	'W' option	Contact us

SPECIFICATION

ELECTRICAL CHARACTERISTICS

Impedance		75 Ω
Frequency		DC-6 GHz
VSWR	1.05 +	0,0350 x F(GHz) Maxi
Insertion loss		0.1 √F(GHz) dB Maxi
RF leakage	- (AD - F(GHz)) dB Maxi
Voltage rating		500 Veff Maxi
Dielectric withstanding voltage		1500 Veff mini
Insulation resistance		5000 MΩ mini

CABLE ASSEMBLY

Stripping	a	b	c	d	e	f
mm	3,50	10,8	18,0	0,00	0,00	0,00

Assembly instruction : **Crimp 02**

Recommended cable(s)
DRAKA HDTV 0.6/2.8
CAE HDTV HD 0628

Characteristics indicated on this data sheet are those that can be achieved with the highest performance cable. Intrinsic limitations of the cable may diminish the performance of the assembly

Cable retention

- pull off **110** N mini
 - torque **NA** N.cm

MECHANICAL CHARACTERISTICS

Center contact retention		
Axial force – Mating end	10	N mini
Axial force – Opposite end	10	N mini
Torque	NA	N.cm mini

TOOLING

Part Number	Description	Hexagon
.	.	.
R282.223.000	CRIMPING TOOL	5.41
R282.235.011	CRIMPING DIES M22520/5-11	5.41
R282.281.000	CRIMPING TOOL	2 x 4 Pts(Pos 6)
R282.968.023	POSITIONER FOR CRIMPING TOOL	

Recommended torque		
Mating		N.cm
Panel nut		N.cm
Clamp nut		N.cm
A/F clamp nut	0,0000	mm

Mating life	1000	Cycles mini
Weight	8,8070	g

ENVIRONMENTAL

Operating temperature	-65/+165	° C
Hermetic seal		Atm.cm3/s
Panel leakage		

OTHER CHARACTERISTICS

Issue : 0843 B

In the effort to improve our products, we reserve the right to make changes judged to be necessary.

