

**STRAIGHT PLUG CRIMP TYPE**

**CABLE 0.8/3.7 PACK.100**

**R142.077.722**

Series : **BNC 75 HDTV**

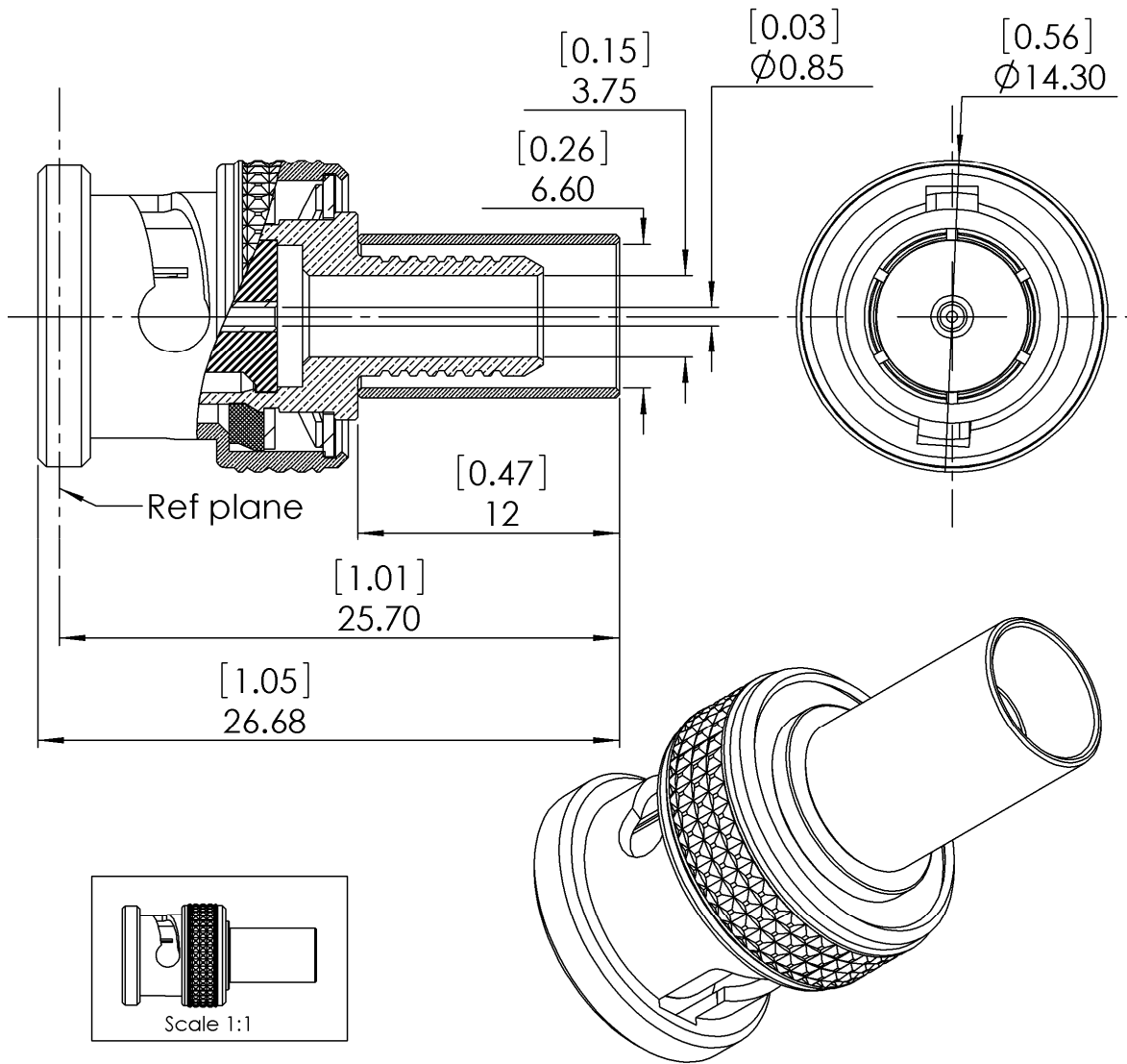

All dimensions are in mm.

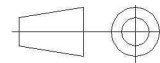

COMPONENTS	MATERIALS	PLATING (µm)
BODY	BRASS	NPGR
CENTER CONTACT	BRASS	NPGR
OUTER CONTACT	BRASS	NPGR
INSULATOR	PTFE	
GASKET	SILICONE RUBBER	
OTHERS PARTS	BRASS	BBR
-	-	-
-	-	-

Issue : 0843 B

In the effort to improve our products, we reserve the right to make changes judged to be necessary.



**STRAIGHT PLUG CRIMP TYPE**

**R142.077.722**

**CABLE 0.8/3.7 PACK.100**

Series : **BNC 75 HDTV**

**PACKAGING**

Standard	Unit	Other
<b>100</b>	<b>'W' option</b>	<b>Contact us</b>

**SPECIFICATION**

**ELECTRICAL CHARACTERISTICS**

Impedance		<b>75</b> Ω
Frequency		<b>DC-6</b> GHz
VSWR	<b>1.05</b> +	<b>0,0350</b> x F(GHz) Maxi
Insertion loss		<b>0.1</b> √F(GHz) dB Maxi
RF leakage	- (	<b>AD</b> - F(GHz)) dB Maxi
Voltage rating		<b>500</b> Veff Maxi
Dielectric withstanding voltage		<b>1500</b> Veff mini
Insulation resistance		<b>5000</b> MΩ mini

**CABLE ASSEMBLY**

Stripping	a	b	c	d	e	f
mm	3,50	10,8	18,0	0,00	0,00	0,00

Assembly instruction : **Crimp 02**

Recommended cable(s)  
**DRAKA 0.8/3.7**  
**BELDEN 1505A**  
**CAE HD 08370**

Characteristics indicated on this data sheet are those that can be achieved with the highest performance cable. Intrinsic limitations of the cable may diminish the performance of the assembly

Cable retention

- pull off **136** N mini  
 - torque **NA** N.cm

**MECHANICAL CHARACTERISTICS**

Center contact retention		
Axial force – Mating end	<b>10</b>	N mini
Axial force – Opposite end	<b>10</b>	N mini
Torque	<b>NA</b>	N.cm mini

**TOOLING**

Part Number	Description	Hexagon
.	.	.
<b>R282.235.013</b>	<b>CRIMPING DIES</b>	<b>6.48</b>
<b>R282.281.000</b>	<b>CRIMPING TOOL</b>	<b>2 x 4</b> Pts(Pos 7)
<b>R282.968.023</b>	<b>POSITIONER FOR CRIMPING TOOL</b>	
<b>R282.293.000</b>	<b>CRIMPING TOOL M22520/5-01</b>	

Recommended torque		
Mating		N.cm
Panel nut		N.cm
Clamp nut		N.cm
A/F clamp nut	<b>0,0000</b>	mm

Mating life	<b>1000</b>	Cycles mini
Weight	<b>9,0960</b>	g

**ENVIRONMENTAL**

Operating temperature	<b>-65/+165</b>	° C
Hermetic seal		Atm.cm3/s
Panel leakage		

**OTHER CHARACTERISTICS**

**Issue : 0843 B**

In the effort to improve our products, we reserve the right to make changes judged to be necessary.

