

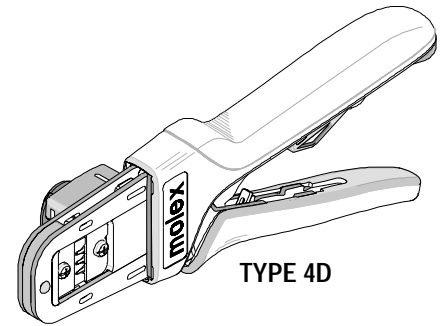

# HAND CRIMP TOOL Specification Sheet Order No. 63819-0900



## FEATURES

- A full cycle ratcheting hand tool ensures complete crimps
- Ergonomic soft grip handles for comfortable crimping
- A precision user-friendly terminal locator wire stop holds terminals in the proper crimping position
- Right and Left handed applications
- This tool is IPC/WHMA A-620 Class 2 compliant as indicated
- This tool is RoHS compliant, however RoHS compliant is not required

## SCOPE

Products: Mini-Fit™ Jr. Male and Female Crimp Terminals, 16 - 24 AWG.

Terminal Series No.	Terminal Order No.				Wire Size		Insulation Diameter Maximum		Strip Length	
	Loose Piece		Reel		AWG	mm <sup>2</sup>	mm	In.	mm	In.
5556	39-00-0078	39-00-0174	39-00-0077	39-00-0173	16	1.30	3.10	.122	3.00-3.50	.118-.138
	39-00-0080	39-00-0180	39-00-0079	39-00-0179						
	39-00-0090	39-00-0186	39-00-0089	39-00-0185						
	39-00-0094	39-00-0199	39-00-0093	39-00-0198						
	39-00-0113	39-00-0205	39-00-0112	39-00-0204						
	39-00-0119	39-00-0212	39-00-0118	39-00-0211						
	39-00-0142	39-00-0218	39-00-0141	39-00-0217						
	39-00-0158	39-00-0448	39-00-0157	39-00-0447						
	39-00-0168		39-00-0167							
	39-00-0039	39-00-0182	39-00-0038	39-00-0181	18-24	0.80-0.20	3.10	.122	3.00-3.50	.118-.138
	39-00-0056	39-00-0195	39-00-0055	39-00-0194						
	39-00-0060	39-00-0201	39-00-0059	39-00-0200						
	39-00-0074	39-00-0208	39-00-0073	39-00-0207						
	39-00-0109	39-00-0214	39-00-0108	39-00-0213						
	39-00-0115	39-00-0406	39-00-0114	39-00-0405						
	39-00-0154	39-00-0408	39-00-0153	39-00-0407						
	39-00-0164	39-00-0429	39-00-0163	39-00-0428						
	39-00-0170	39-00-0441	39-00-0169	39-00-0440						
39-00-0176	40-13-0852	39-00-0175	40-13-0851							
5558	39-00-0082	39-00-0131	39-00-0081	39-00-0130	16	1.30	3.10	.122	3.00-3.50	.118-.138
	39-00-0084	39-00-0148	39-00-0083	39-00-0147						
	39-00-0096	39-00-0224	39-00-0095	39-00-0223						
	39-00-0100	39-00-0450	39-00-0099	39-00-0449						
	39-00-0125		39-00-0124		18-24	0.80-0.20	3.10	.122	3.00-3.50	.118-.138
	39-00-0041	39-00-0127	39-00-0040	39-00-0126						
	39-00-0054	39-00-0220	39-00-0053	39-00-0219						
	39-00-0062	39-00-0431	39-00-0061	39-00-0430						
	39-00-0076	40-13-0854	39-00-0075	40-13-0853						
39-00-0121		39-00-0120								

Hand Crimp Tool For Mini-Fit™ Jr. Male and Female Crimp Terminals

Terminal Series No.	Terminal Order No.				Wire Size		Insulation Diameter Maximum		Strip Length	
	Loose Piece		Reel		AWG	mm <sup>2</sup>	mm	In.	mm	In.
30490	30490-1012	30490-2012	30490-1002	30490-9802	18-24	0.80-0.20	3.10	.122	3.00-3.50	.118-.138
			30490-2002	30490-9902						
44476	44476-3112		44476-3111		16	1.30	3.10	.122	3.00-3.50	.118-.138
	44476-1112	44476-1212	44476-1111		18-20	0.80-0.50				
44478	44478-3112	44478-3212	44478-3111	44478-3211	16	1.30	3.10	.122	3.00-3.50	.118-.138
	44478-1112		44478-1111	44478-1211	18-20	0.80-0.50				
44485	44485-3212	44485-3412	44485-3211	44485-3411	16	1.30	3.10	.122	3.00-3.50	.118-.138
	44485-3312		44485-3311							
	44485-1212	44485-1412	44485-1211	44485-1411	18-24	0.80-0.20				
	44485-1312		44485-1311							
45750	45750-3112	45750-3212	45750-3111	45750-3211	16	1.30	3.10	.122	3.00-3.50	.118-.138
	45750-1112	45750-1212	45750-1111	45750-1211	18-20	0.80-0.50				
46012	46012-3142	46012-3242	46012-3141	46012-3241	16	1.30	3.10	.122	3.00-3.50	.118-.138
	46012-1142	46012-1242	46012-1141	46012-1241	18-20	0.80-0.50				
46018	46018-3542		46018-3541		16	1.30	3.10	.122	3.00-3.50	.118-.138
	46018-1542		46018-1541		18-20	0.80-0.50				
46083	46083-3112	46083-3212	46083-3111	46083-3211	16	1.30	3.10	.122	3.00-3.50	.118-.138
	46083-3122	46083-3222	46083-3121	46083-3221						
	46083-1112	46083-1212	46083-1111	46083-1211	18-20	0.80-0.50				
	46083-1122	46083-1222	46083-1121	46083-1221						
46098	46098-3542		46098-3541		16	1.30	3.10	.122	3.00-3.50	.118-.138
	46098-1542		46098-1541		18-20	0.80-0.50				

⚠ Customer to cut off terminal from reel: 0.2mm (.008") maximum Cut-off Tab.  
+ See conditions on page 3

**DEFINITION OF TERMS**

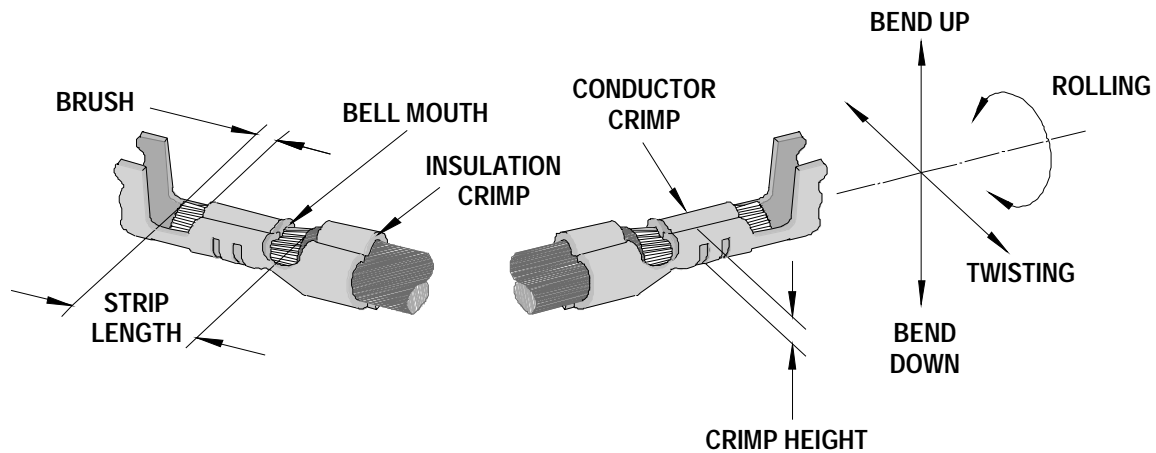

The above terminal drawing is a generic terminal representation. It is not an image of a terminal listed in the scope.

**CONDITIONS:**

After crimping, the conductor profiles should measure the following.

Terminal Series No.	Wire Size		Conductor Crimp				Insulation Crimp				Pull Force Minimum		+ Profile		
			Height (Ref.)		Width (Ref.)		Height (Ref.)		Width (Ref.)						
	AWG	mm <sup>2</sup>	mm	In.	mm	In.	mm	In.	mm	In.	N	Lb.	16	18	20-24
5556	16	1.30	1.06-1.16	.042-.046	1.92	.076	2.82	.111	2.89	.114	68.5	15.40	X		
	18	0.80	1.00-1.10	.039-.043	1.69	.067	2.38	.094	2.68	.106	88.0	19.80		X	
	20	0.50	0.83-0.93	.033-.037	1.64	.065	2.24	.088	2.65	.104	58.7	13.20			X
	22	0.35	0.80-0.90	.031-.035	1.63	.064	2.24	.088	2.61	.103	39.1	8.00			X
	24	0.20	0.78-0.88	.030-.034	1.63	.064	2.21	.087	2.60	.102	29.3	6.60			X
5558	16	1.30	1.06-1.16	.042-.046	1.92	.076	2.82	.111	2.89	.114	68.5	15.40	X		
	18	0.80	1.00-1.10	.039-.043	1.69	.067	2.38	.094	2.68	.106	88.0	19.80		X	
	20	0.50	0.83-0.93	.033-.037	1.64	.065	2.24	.088	2.65	.104	58.7	13.20			X
	22	0.35	0.80-0.90	.031-.035	1.63	.064	2.24	.088	2.61	.103	39.1	8.00			X
	24	0.20	0.78-0.88	.030-.034	1.63	.064	2.21	.087	2.60	.102	29.3	6.60			X
30490	18	0.80	1.00-1.10	.039-.043	1.69	.067	2.38	.094	2.68	.106	88.0	19.80		X	
	20	0.50	0.83-0.93	.033-.037	1.64	.065	2.24	.088	2.65	.104	58.7	13.20			X
	22	0.35	0.80-0.90	.031-.035	1.63	.064	2.24	.088	2.61	.103	39.1	8.00			X
	24	0.20	0.78-0.88	.030-.034	1.63	.064	2.21	.087	2.60	.102	29.3	6.60			X
44476	16	1.30	1.06-1.16	.042-.046	1.92	.076	2.82	.111	2.89	.114	68.5	15.40	X		
	18	0.80	1.00-1.10	.039-.043	1.69	.067	2.38	.094	2.68	.106	68.5	15.40		X	
	20	0.50	0.83-0.93	.033-.037	1.64	.065	2.24	.088	2.65	.104	58.7	13.20			X
44478	16	1.30	1.06-1.16	.042-.046	1.92	.076	2.82	.111	2.89	.114	68.5	15.40	X		
	18	0.80	1.00-1.10	.039-.043	1.69	.067	2.38	.094	2.68	.106	68.5	15.40		X	
	20	0.50	0.83-0.93	.033-.037	1.64	.065	2.24	.088	2.65	.104	58.7	13.20			X
44485	16	1.30	1.06-1.16	.042-.046	1.92	.076	2.82	.111	2.89	.114	68.5	15.40	X		
	18	0.80	1.00-1.10	.039-.043	1.69	.067	2.38	.094	2.68	.106	68.5	15.40		X	
	20	0.50	0.83-0.93	.033-.037	1.64	.065	2.24	.088	2.65	.104	58.7	13.20			X
	22	0.35	0.80-0.90	.031-.035	1.63	.064	2.24	.088	2.61	.103	39.1	8.00			X
	24	0.20	0.78-0.88	.030-.034	1.63	.064	2.21	.087	2.60	.102	29.3	6.60			X
45750	16	1.30	1.06-1.16	.042-.046	1.92	.076	2.82	.111	2.89	.114	68.5	15.40	X		
	18	0.80	1.00-1.10	.039-.043	1.69	.067	2.38	.094	2.68	.106	68.5	15.40		X	
	20	0.50	0.83-0.93	.033-.037	1.64	.065	2.24	.088	2.65	.104	58.7	13.20			X
46012	16	1.30	1.06-1.16	.042-.046	1.92	.076	2.82	.111	2.89	.114	68.5	15.40	X		
	18	0.80	1.00-1.10	.039-.043	1.69	.067	2.38	.094	2.68	.106	68.5	15.40		X	
	20	0.50	0.83-0.93	.033-.037	1.64	.065	2.24	.088	2.65	.104	58.7	13.20			X
46018	16	1.30	1.06-1.16	.042-.046	1.92	.076	2.82	.111	2.89	.114	68.5	15.40	X		
	18	0.80	1.00-1.10	.039-.043	1.69	.067	2.38	.094	2.68	.106	68.5	15.40		X	
	20	0.50	0.83-0.93	.033-.037	1.64	.065	2.24	.088	2.65	.104	58.7	13.20			X
46083	16	1.30	1.06-1.16	.042-.046	1.92	.076	2.82	.111	2.89	.114	68.5	15.40	X		
	18	0.80	1.00-1.10	.039-.043	1.69	.067	2.38	.094	2.68	.106	68.5	15.40		X	
	20	0.50	0.83-0.93	.033-.037	1.64	.065	2.24	.088	2.65	.104	58.7	13.20			X
46098	16	1.30	1.06-1.16	.042-.046	1.92	.076	2.82	.111	2.89	.114	68.5	15.40	X		
	18	0.80	1.00-1.10	.039-.043	1.69	.067	2.38	.094	2.68	.106	68.5	15.40		X	
	20	0.50	0.83-0.93	.033-.037	1.64	.065	2.24	.088	2.65	.104	58.7	13.20			X
+ To Achieve IPC-A-620 Class 2 Crimps, the following over-all wire insulation diameter ranges are recommended: 16 AWG Profile: 1.90-3.10mm (.075-.122 inch) 18 AWG Profile: 1.68-2.85mm (.066-.112 inch) 20-24 AWG Profile: 1.40-2.54mm (.055-.100 inch)															

## OPERATION

**CAUTION:** Install only Molex terminals listed above with this tool. Do not crimp hardened objects as damage can occur to the tool or die.

Open the tool by squeezing the handles together. At the end of the closing stroke, the ratchet mechanism will release the handles and the hand tool will spring open. See Figure 1.

## Crimping Terminals

1. Select the desired terminal listed in the preceding charts.
2. Make sure the center of the locator is in the down position. With the locator attached, push the locator button on the back of the hand tool to bring the locator forward through the tooling. See Figure 2.

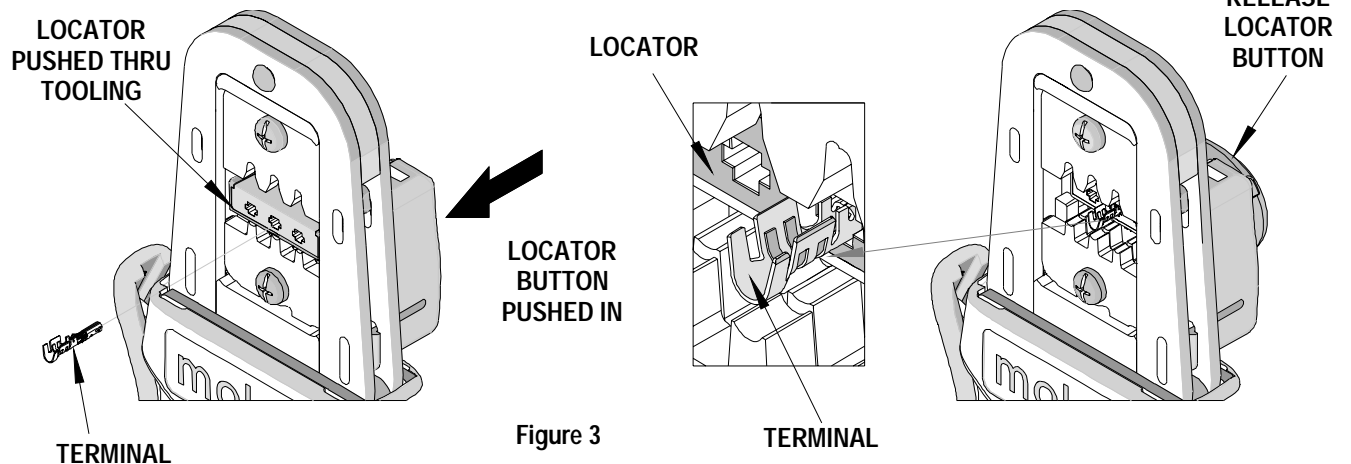
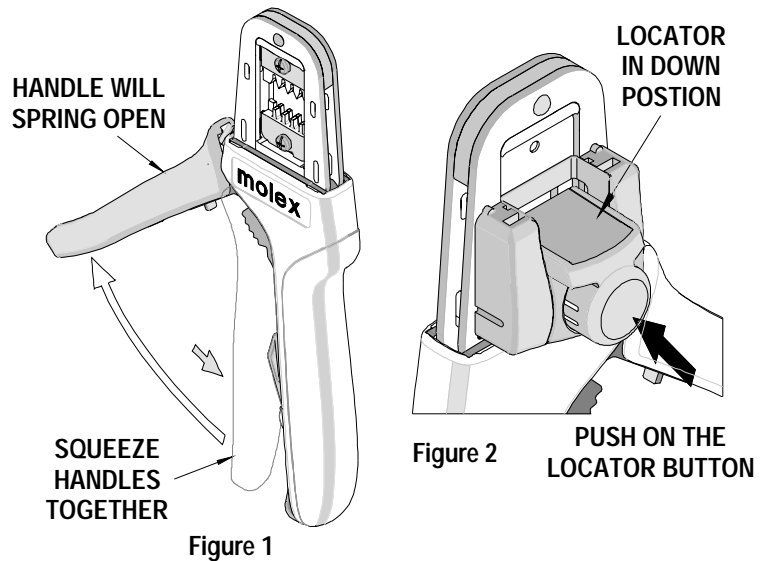

3. While holding the locator button in, load the terminal into the proper nest opening in the locator based on the wire gauge or terminal type markings on the hand tooling. See Figure 3.
4. Release the locator button, allowing the locator to return to the crimping position.
5. Close the tool handle until the first ratchet position engages. See Figure 4.
6. Insert the properly stripped wire through the terminal and against the wire stop. See Figure 5.
7. Crimp the terminal by squeezing the tool handles until the ratchet mechanism cycle has been completed. Release the handles to open the jaws.

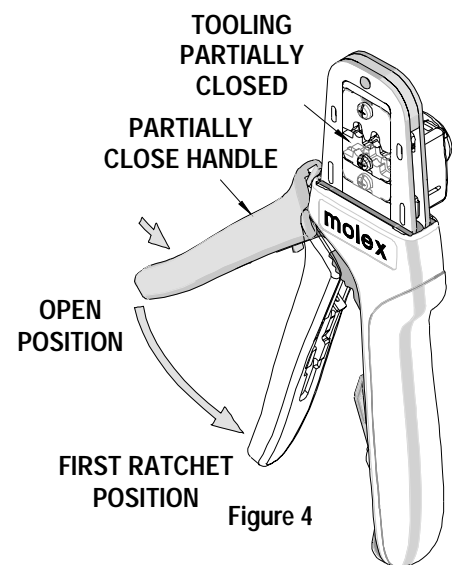

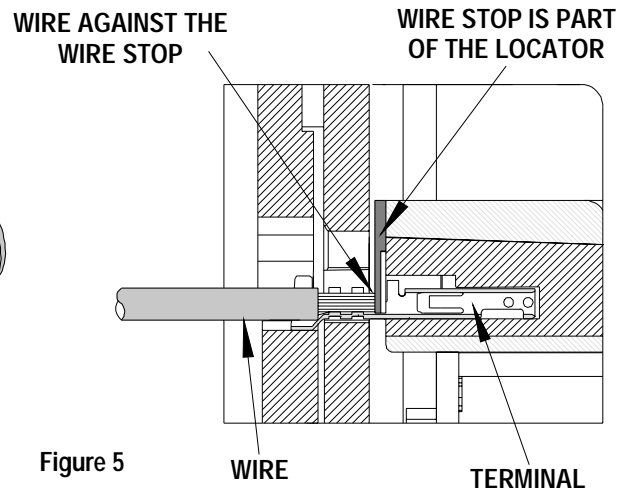
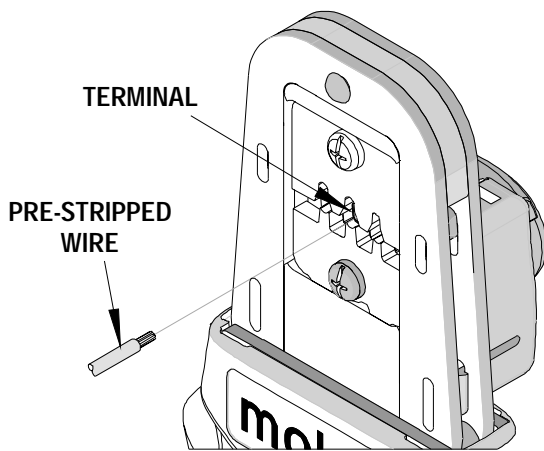

**Note:** The tamper proof ratchet action will not release the tool until it has been fully closed.

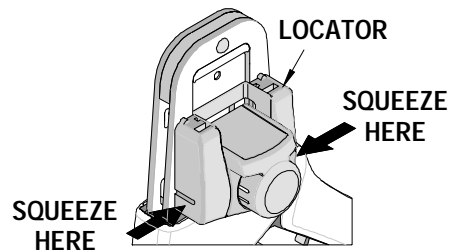
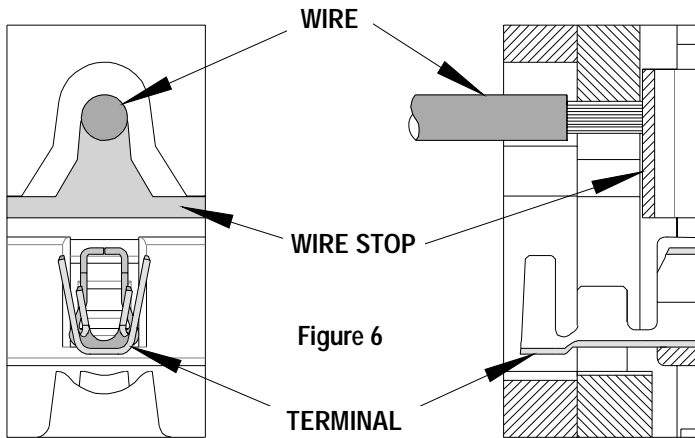

MAKE SURE CENTER OF LOCATOR IS IN THE DOWN POSITION

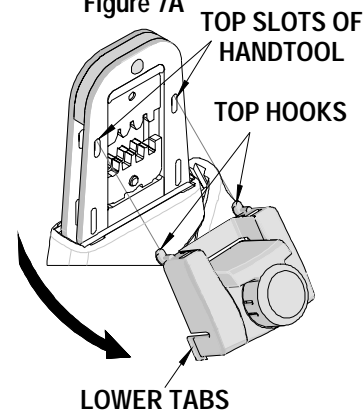

8. Remove the crimped terminal from the terminal locator by pulling on the wire.
9. Visually inspect the crimped terminal for proper crimp location.
10. On some large O.D. wires, it may not be possible to insert the wire with the tool partially closed. Those wires should be inserted with the hand tool in the open position. Insert the wire above the terminal in the punch and against the wire stop then close the tool. See Figure 6.

**Note:**

A crimp height chart is provided with this manual as Reference Only. Due to the wide range of wires, strands, insulation diameters, and durometers available, actual crimp height measurements may vary slightly. An occasional, destructive, pull force test should be performed to check hand tool crimp. Pull Force value Must exceed the Minimum pull force specifications listed.

## Locator Replacement

See the parts list on the last page of this document for the proper locator order number. Follow the steps below to replace the locator.

1. Open the crimp hand tool.
2. Squeeze gently on the lower area shown in Figure 7A with your thumb and index finger. The lower tabs of the locator should disengage from the hand tool.
3. Lift and pull away from the hand tool. The top locator hooks should slip out of the top slots easily. See Figure 7A.
4. To reinstall the new locator, make sure the hand tool is in the open position.
5. Press the red insert down as far as it will go as shown in Figure 7B.
6. Holding onto the lower part of the locator with your thumb and index finger, insert the locators top hooks (2) into the hand tool top slots.
7. Rotate the locator down and press the lower tabs into the two bottom slots of the hand tool. To secure the locator into place, the lower tabs must snap into place on the hand tool frame.

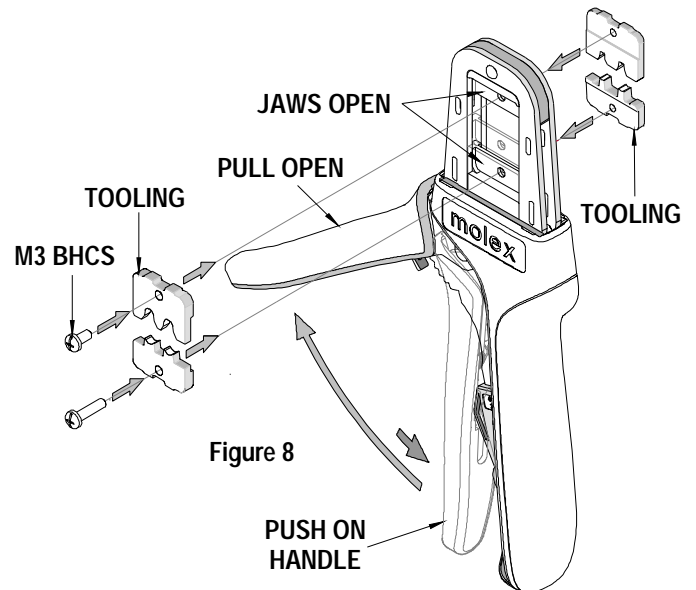

## Right or Left Hand Operation

This hand tool has an added feature that can be converted from a right handed application to a left handed application. It is necessary to reverse the tooling if using the left handed application along with the locator. Follow the steps below:

1. The locator must be removed before reversing the tooling.
2. Remove the M3 BHCS which is holding the upper tooling.
3. Flip the upper tooling to the opposite side and replace the M3 BHCS. Make sure the small markings on the front and back of the hand tool frame, match up and are on the outside of the hand tool frame. See Figure 8 and 9.
4. Do the same thing with the lower tooling and tighten the M3 screws. Be sure the small markings line up.
5. Reinstall the locator by following the Instructions in the locator replacement section.

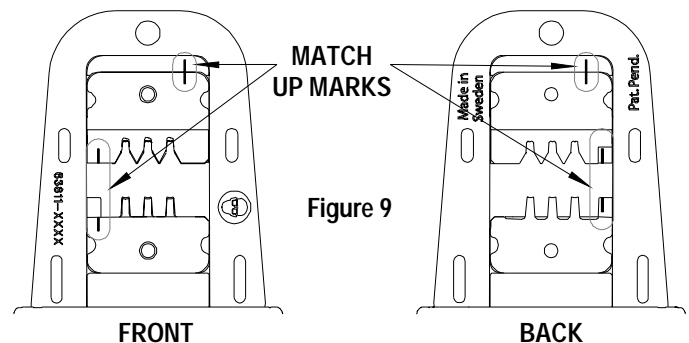

## Maintenance

It is recommended that each operator of the tool be made aware of, and responsible for, the following maintenance steps:

1. Remove dust, moisture, and other contaminants with a clean brush, or soft, lint free cloth.
2. Do not use any abrasive materials that could damage the tool.

3. Make certain all pins; pivot points and bearing surfaces are protected with a thin coat of high quality machine oil. Do not oil excessively. The tool was engineered for durability but like any other equipment it needs cleaning and lubrication for a maximum service life of trouble free crimping. Light oil (such as 30 weight automotive oil) used at the oil points, every 5,000 crimps or 3 months, will significantly enhance the tool life.

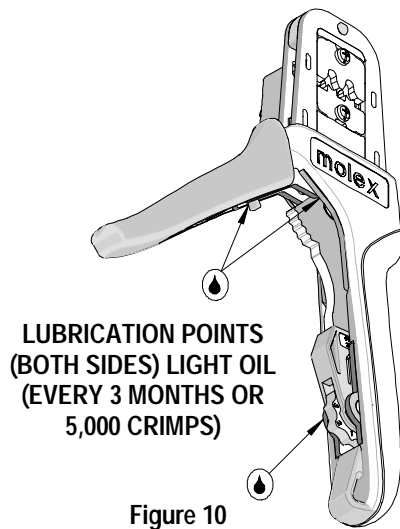

Figure 10

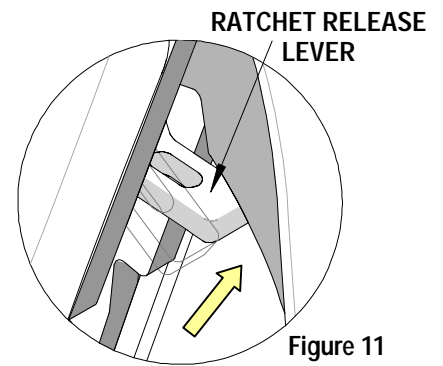

Figure 11

4. Wipe excess oil from hand tool, particularly from crimping area. Oil transferred from the crimping area onto certain terminations may affect the electrical characteristics of an application.
5. When tool is not in use, keep the handles closed to prevent objects from becoming lodged in the crimping dies, and store the tool in a clean, dry area.

### Miscrimps or Jams

Should this tool ever become stuck or jammed in a partially closed position, **Do Not force the handles open or closed.** The tool will open easily by pressing up on the ratchet release lever in the movable handle. See Figure 11.

### How to Adjust Tool Preload (See Figure 12)

This hand tool is factory preset to 25-45 LBS. preload. It may be necessary over the life of the tool to adjust tool handle preload force. Listed below are the steps required to adjust the crimping force of the hand tool to obtain proper crimp conditions:

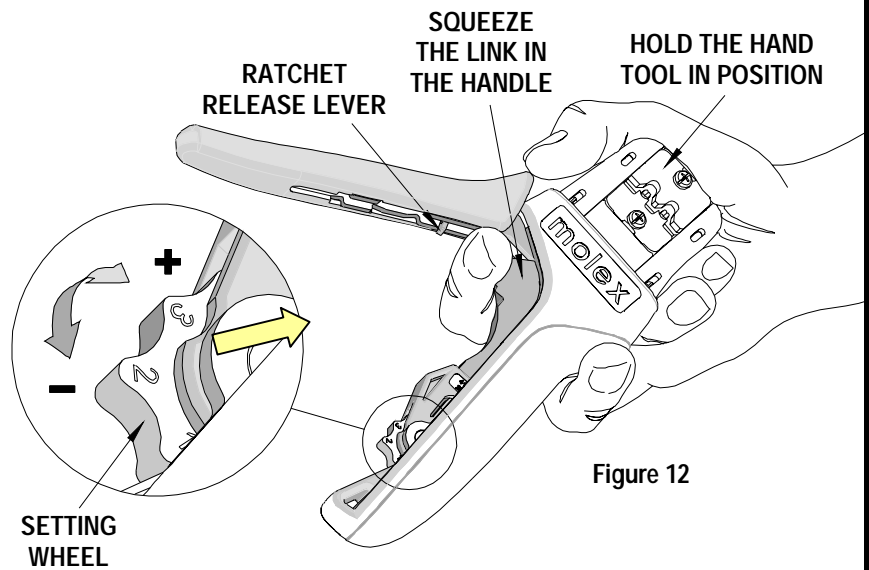

Figure 12

1. Hold the hand tool in the palm of your hand as shown in Figure 12. Using the index finger squeeze the link towards the top of the hand tool frame. This will release the preload adjustment wheel.
2. Rotate the setting wheel counter-clockwise (CCW) to increase handle force. The numbers will display higher. To decrease handle force rotate the setting wheel clockwise (CW).
3. Release the link to lock the setting wheel in place.
4. Check the crimp specifications or conduct a pull test after tool handle preload force is adjusted.

## Warranty

This tool is for electrical terminal crimping purposes only. This tool is made of the best quality materials. All vital components are long life tested. All tools are warranted to be free of manufacturing defects for a period of 30 days. Should such a defect occur, we will repair or exchange the tool free of charge. This repair or exchange will not be applicable to altered, misused, or damaged tools. This tool is designed for hand use only. Any clamping, fixturing, or use of handle extensions voids this warranty.

**CAUTION:** Molex crimp specifications are valid only when used with Molex terminals and tooling.

## CAUTIONS:

1. Manually powered hand tools are intended for low volume or field repair. This tool is **NOT** intended for production use. Repetitive use of this tool should be avoided.
2. Insulated rubber handles are not protection against electrical shock.
3. Wear eye protection at all times.
4. Use only the Molex terminals specified for crimping with this tool.

## Certification

Molex does not certify or re-certify hand tools but rather supplies the following guidelines for customers to re-certify hand tools.

- This tool is qualified to pull force only. See the Molex web site for the Quality Crimp Handbook for more information on pull testing.
- If the tool does not meet minimum pull force values, handle preload should be increased and the pull test rerun, (See How to Adjust Preload).
- When the hand tool is no longer capable of achieving minimum pull force, it should be taken out of service and replaced.



**PARTS LIST**

Item Number	Order Number	Description	Quantity
REF	63819-0900	Hand Crimp Tool	Figure 13
1	63819-0975	Locator Assembly	1
2	63810-0104	Spring, Return	1
3	63810-0105	Spring, Ratchet	1

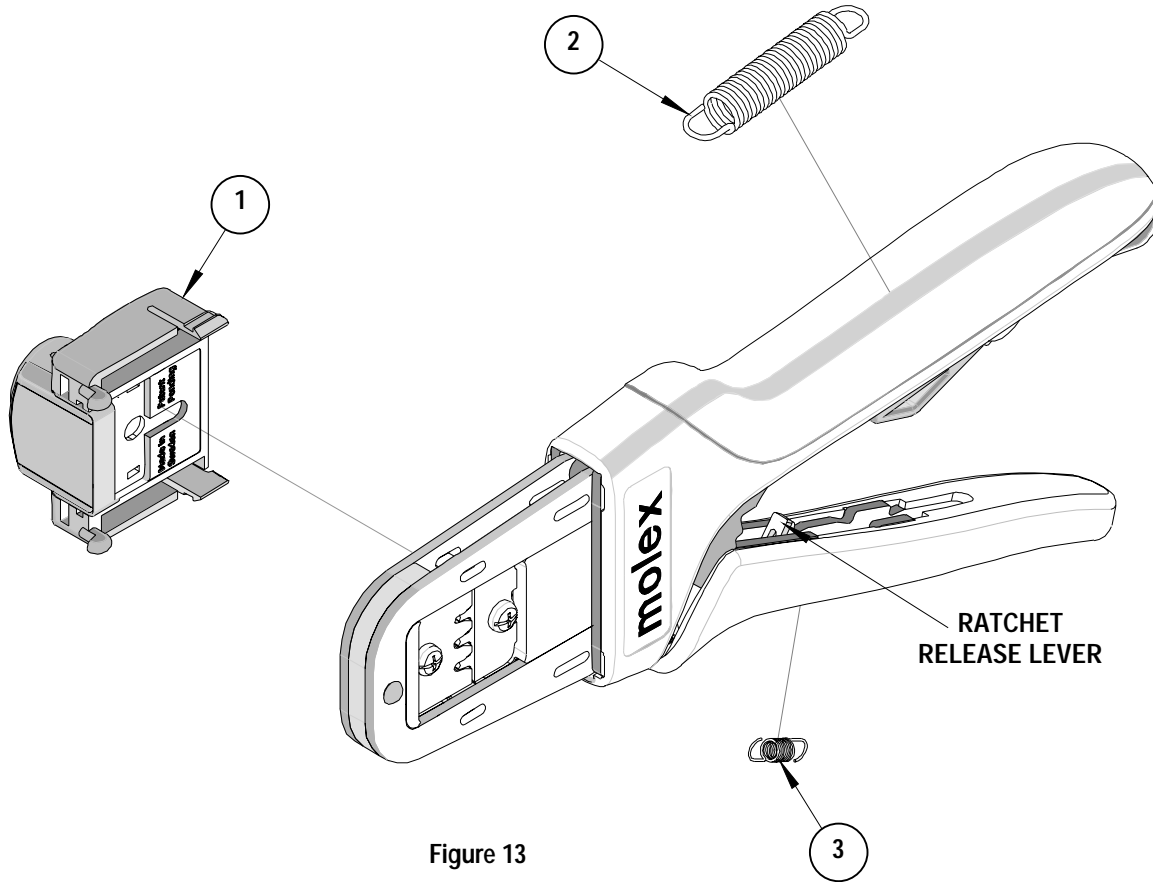

Figure 13

**Americas Headquarters**  
 Lisle, Illinois 60532 U.S.A.  
 1-800-78MOLEX  
 amerinfo@molex.com

**Far East North Headquarters**  
 Yamato, Kanagawa, Japan  
 81-462-65-2324  
 feninfo@molex.com

**Far East South Headquarters**  
 Jurong, Singapore  
 65-6-268-6868  
 fesinfo@molex.com

**European Headquarters**  
 Munich, Germany  
 49-89-413092-0  
 eurinfo@molex.com

**Corporate Headquarters**  
 2222 Wellington Ct.  
 Lisle, IL 60532 U.S.A.  
 630-969-4550  
 Fax: 630-969-1352

Visit our Web site at <http://www.molex.com>