

LOC	DIST	REVISIONS			
GP	00	REV	DATE	BY	APPD
		A	RELEASED PER ECO-09-007387	26MAR2009	CR MS

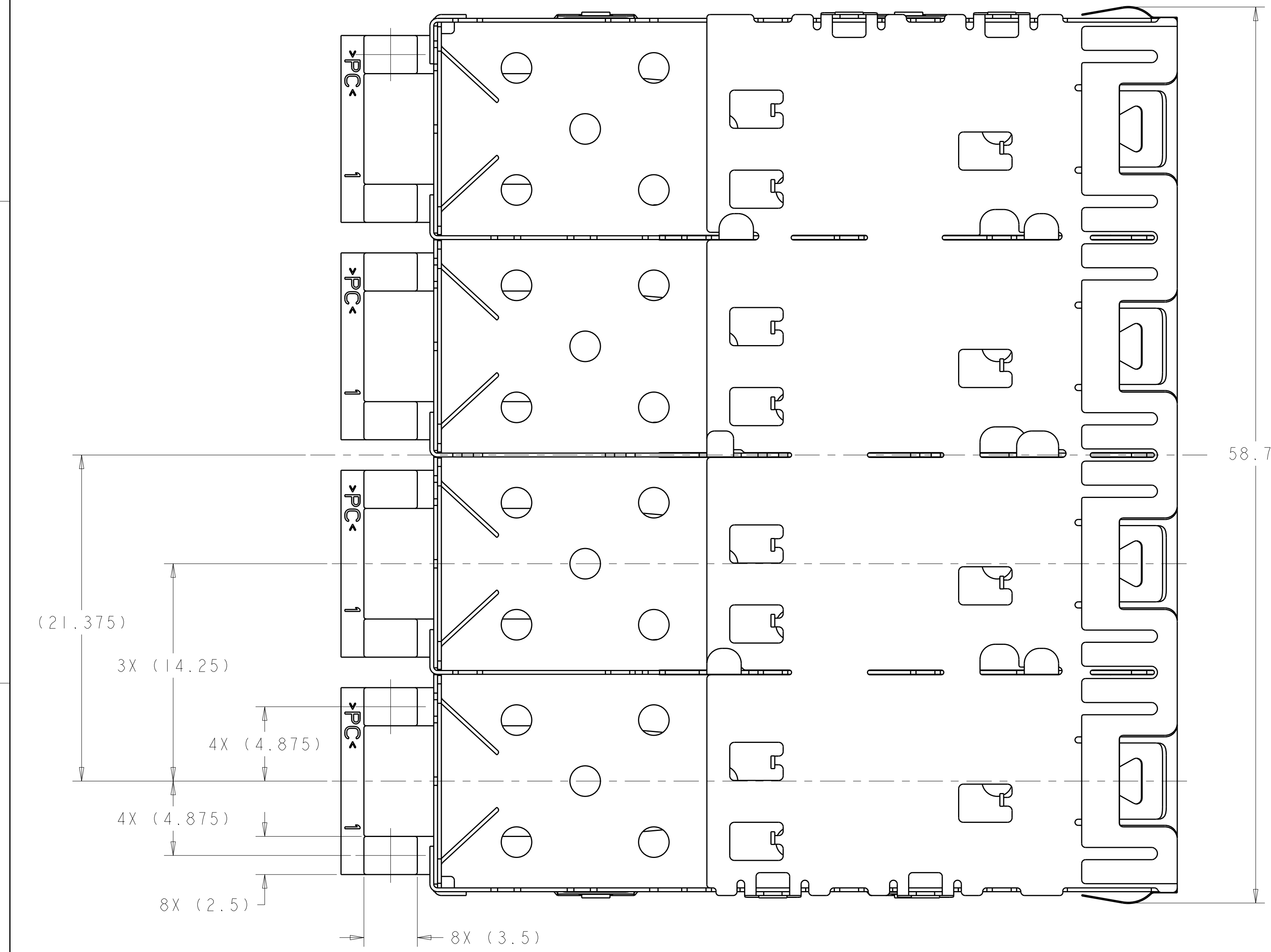

- 1. MATERIAL:
 CAGE ASSEMBLY: 0.25mm THICK NICKEL SILVER ALLOY
 LIGHT PIPE BRACKET: STAINLESS STEEL
 LIGHT PIPE: POLYCARBONATE, CLEAR
- 2. FINISH:
 SPRINGS: MINIMUM OF 0.8um TIN PLATE OVER A MINIMUM OF 0.8um NICKEL UNDERPLATE.
 NON-PLATED EDGES PERMISSIBLE.
- 3. PADS AND VIAS CHASSIS GROUND.
- 4. DATUM AND BASIC DIMENSION ESTABLISHED BY CUSTOMER.
- 5. MATES WITH SFP MSA COMPLIANT TRANSCEIVERS.
- 6. INTERPRETATION OF DATUM REFERENCE FRAME IN ACCORDANCE WITH SECT 4.4.1.1 OF ASME Y14.5M-1994.
- 7. REFERENCE APPLICATION SPEC. 114-13120, HOLE A, FOR RECOMMENDED DRILL HOLE DIAMETER AND PLATING THICKNESS.
- 8. REFERENCE APPLICATION SPEC. 114-13120, HOLE B, FOR RECOMMENDED DRILL HOLE DIAMETER AND PLATING THICKNESS.
- 9. HOLE PATTERN REPEATS FOR EACH PORT. SPACING BETWEEN PORTS IS 14.25mm.
- 10. MINIMUM PC BOARD THICKNESS:
 SINGLE SIDED = 1.50
 DOUBLE SIDED = 2.25
- 11. LIGHT PIPE ASSEMBLY SHIPPED UNASSEMBLED TO CAGE ASSEMBLY. CAGE ASSEMBLY TO BE PRESSED INTO THE PCB PRIOR TO ATTACHING THE LIGHT PIPE ASSEMBLY TO THE CAGE.
- 12. CERTAIN MATING TRANSCEIVERS MAY REQUIRE ADDITIONAL PCB THICKNESS THAT WOULD BE DETERMINED BY THE CUSTOMER.
- 13. PRODUCT HAS NOT COMPLETED QUALIFICATION TESTING.

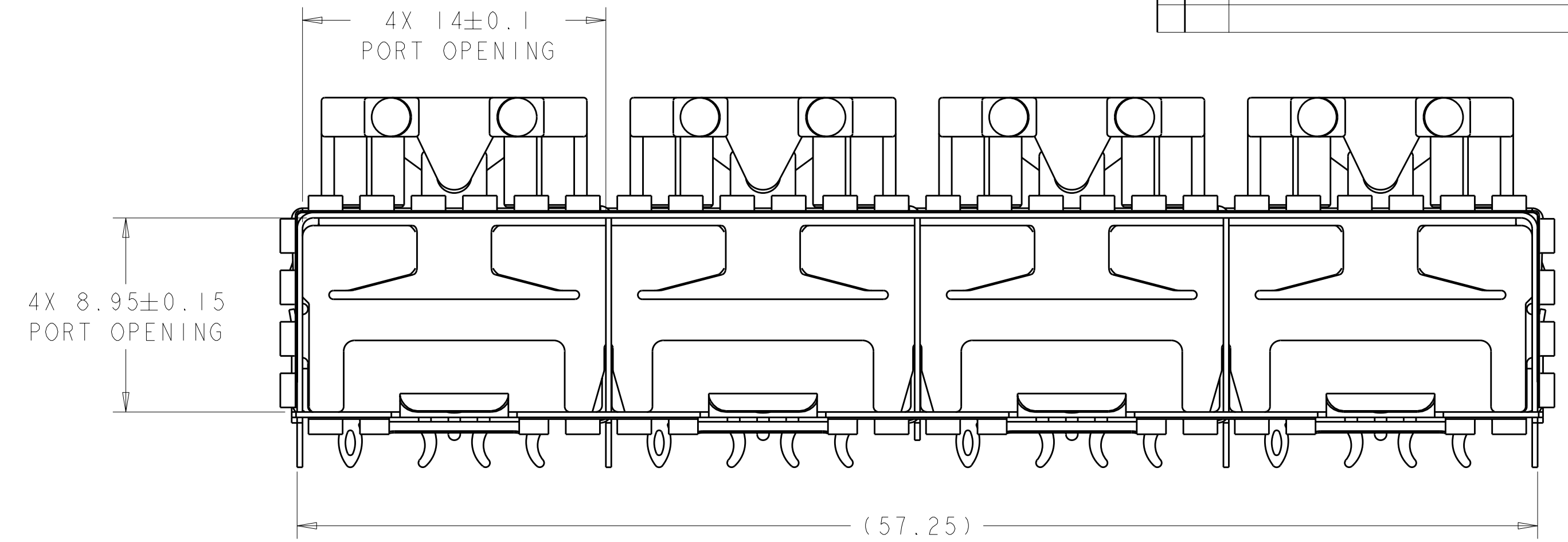
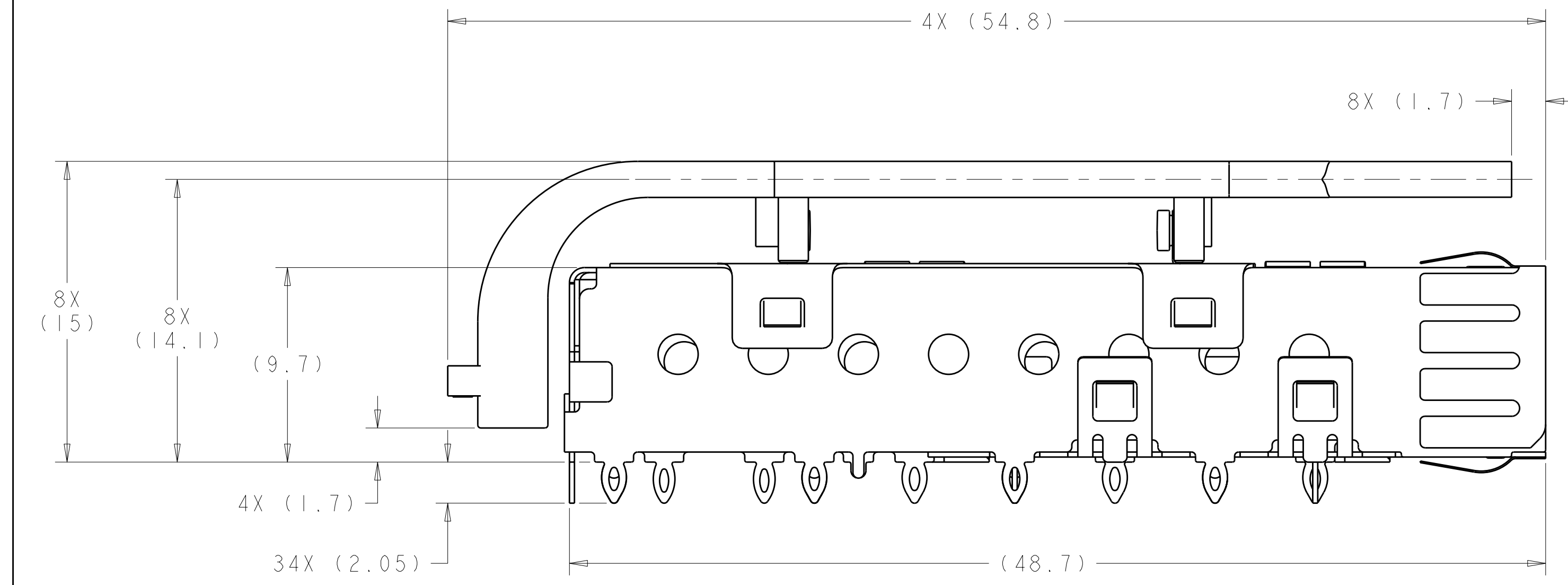
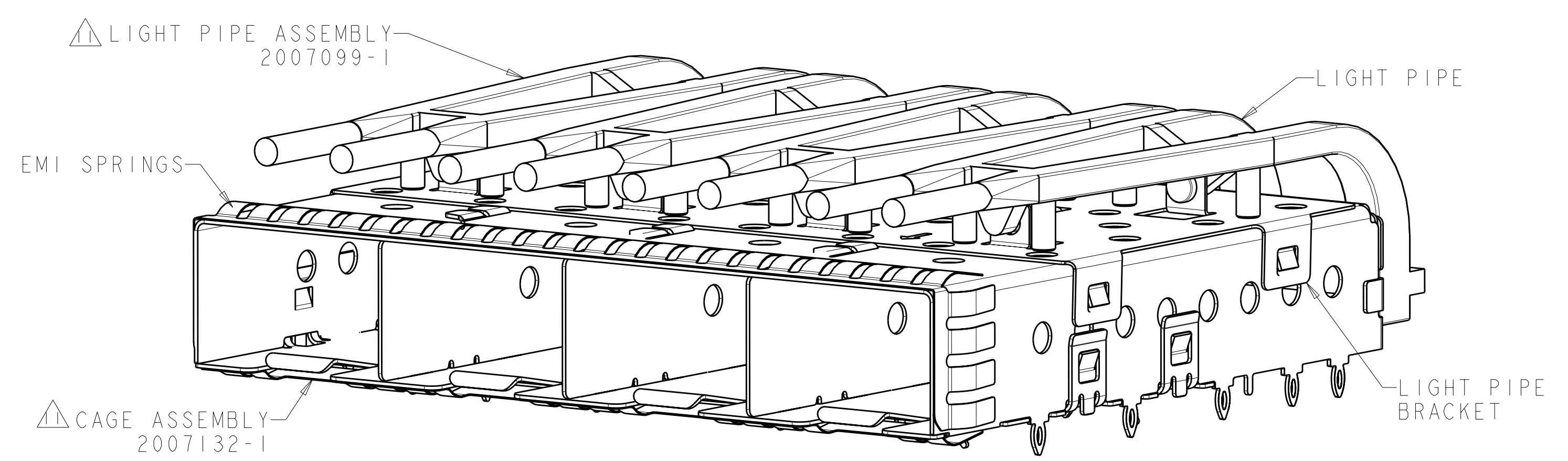

2007178-1
 FINISHED ASSEMBLY
 SCALE 4:1

2007178-1
 PART
 NUMBER

DIMENSIONS: mm		TOLERANCES UNLESS OTHERWISE SPECIFIED: 9 PLC ±0.1 1 PLC ±0.1 5 PLC ±0.1 4 PLC ±0.1 ANGLES ±1°		DWN M. SCHMITT 21JUN2007 CHK M. SCHMITT 21JUN2007 APVD B. WERTZ 21JUN2007		Tyco Electronics Harrisburg, PA 17105-3608	
MATERIAL:		FINISH:		NAME: SFP+ 1X4 CAGE ASSEMBLY PRESS FIT, EXTERNAL EMI SPRINGS WITH LIGHT PIPES		SIZE: CAGE CODE DRAWING NO: 114-13120	
CUSTOMER DRAWING		SCALE: 5:1		SHEET 1 OF 4		REV A	

LOC	DIST	REV	DATE	BY	APPD
GP	00				

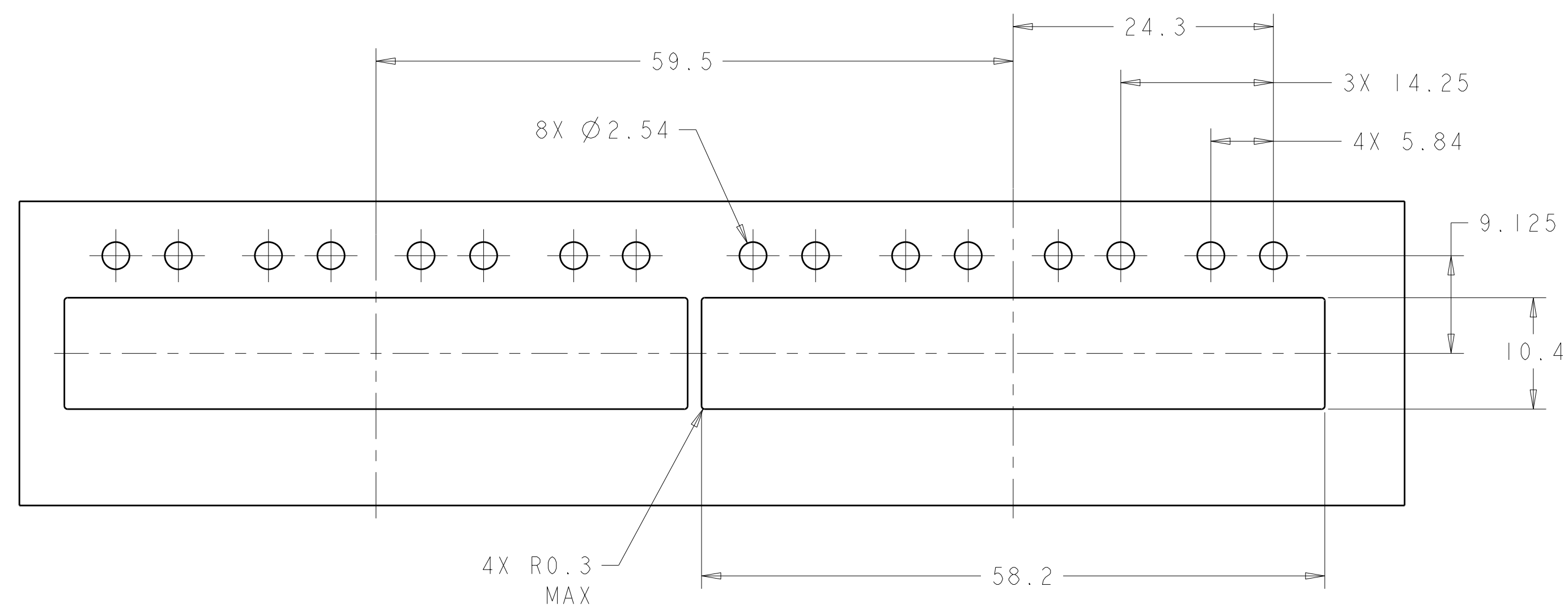

RECOMMENDED BEZEL CUT-OUT
 SINGLE SIDED APPLICATIONS
 SCALE 5:2

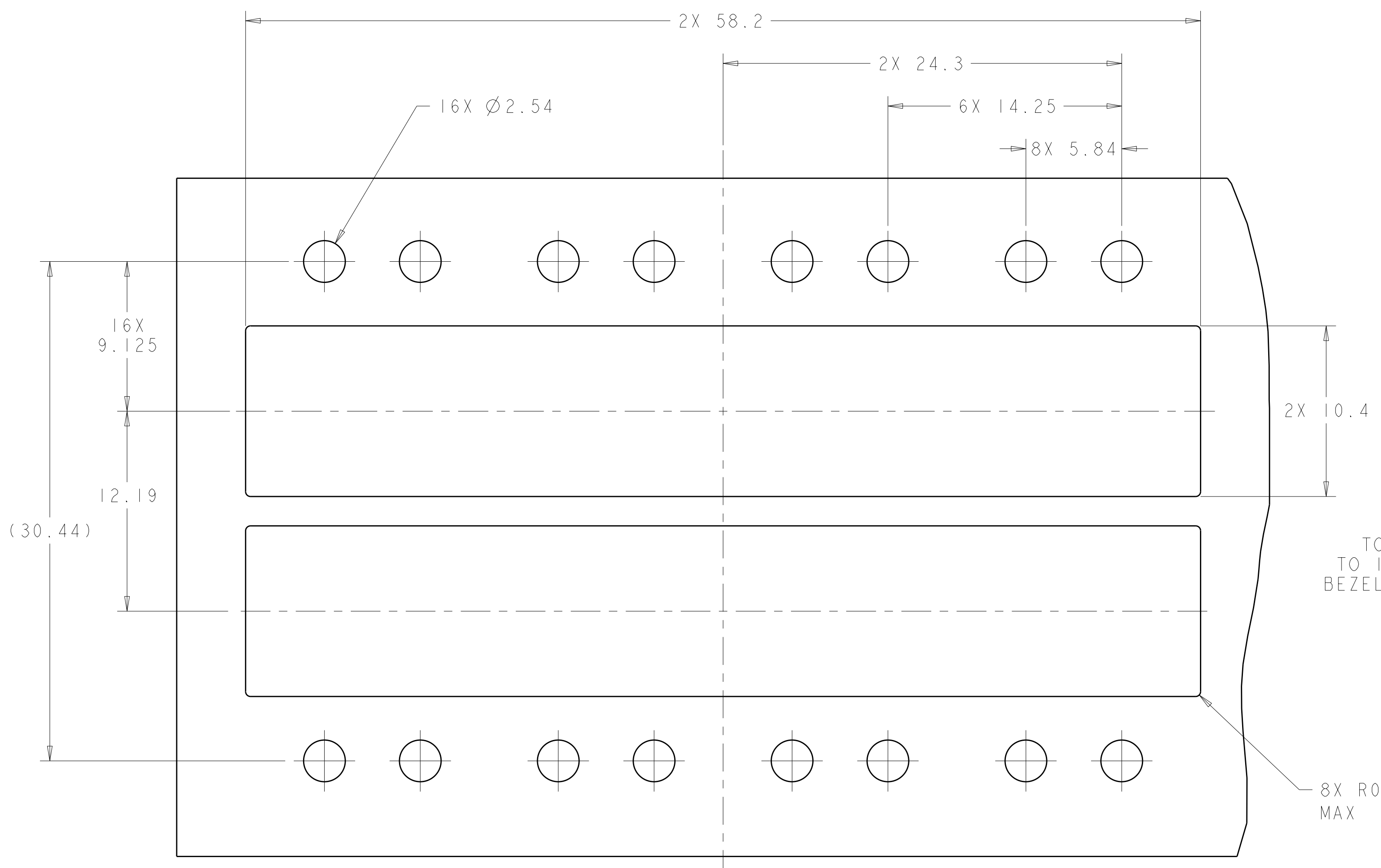

RECOMMENDED BEZEL CUT-OUT
 BELLY TO BELLY APPLICATIONS

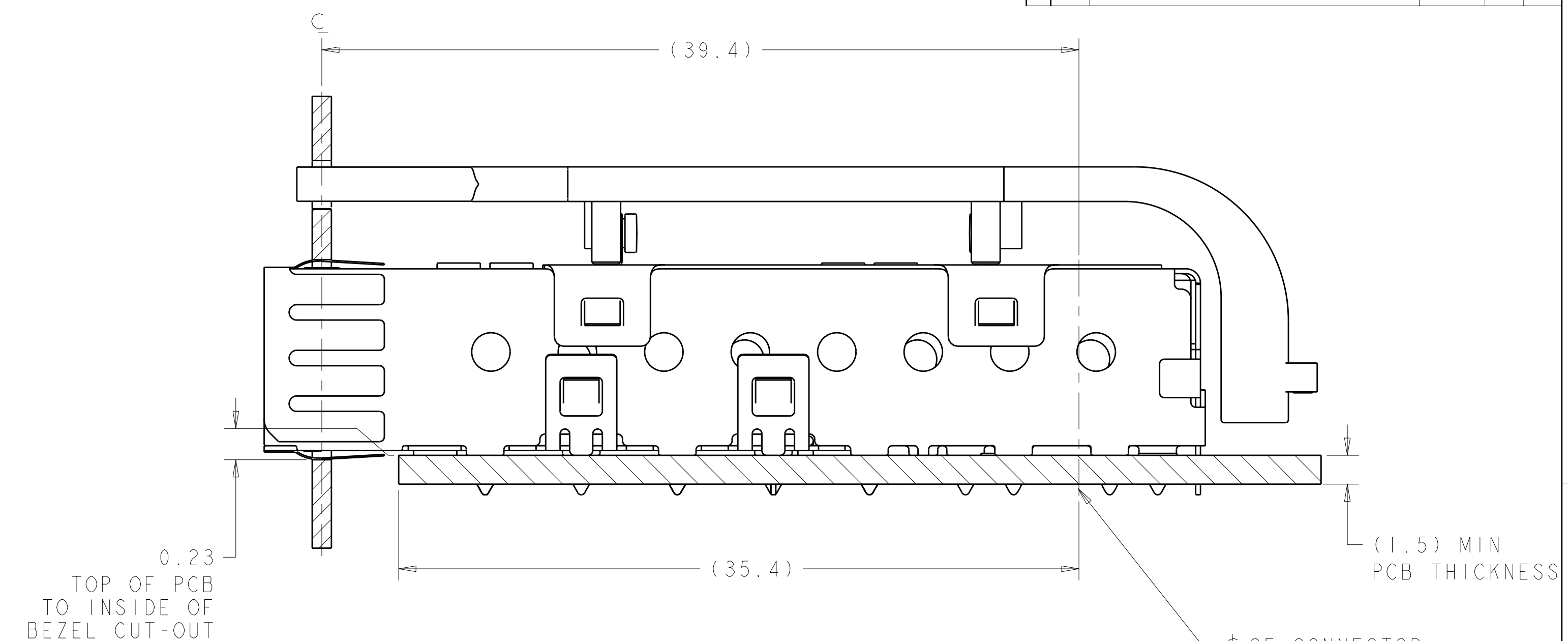

2007178-1
 MOUNTED ON PC BOARD
 SHOWN THRU RECOMMENDED BEZEL

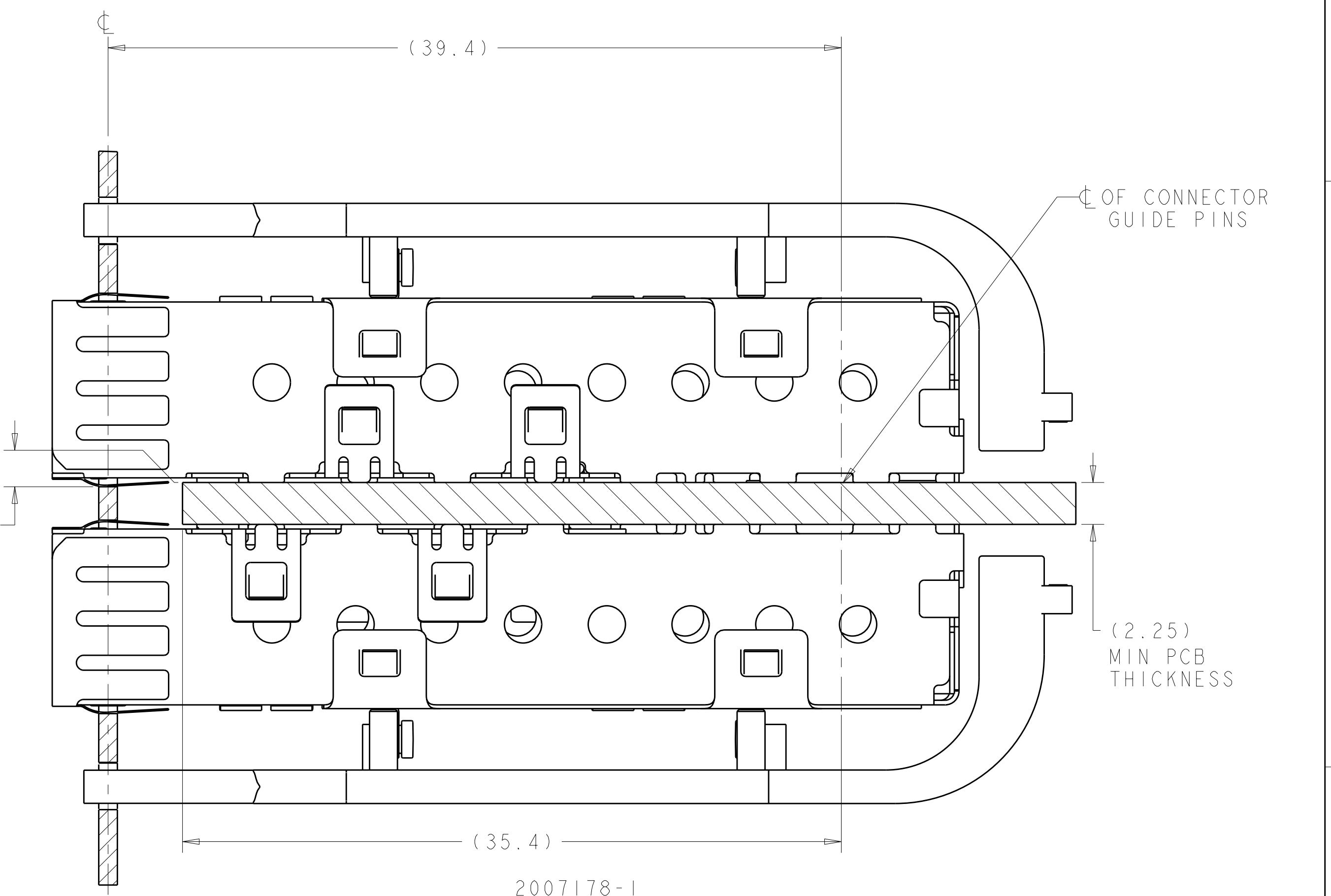

2007178-1
 MOUNTED BELLY TO BELLY ON PC BOARD
 SHOWN THRU RECOMMENDED BEZEL

DIMENSIONS: mm 		TOLERANCES UNLESS OTHERWISE SPECIFIED: 9 PLC ±0.1 1 PLC ±0.1 2 PLC ±0.1 3 PLC ±0.1 4 PLC ±0.1 ANGLES ±1°		DWN M. SCHMITT 21JUN2007 CHK M. SCHMITT 21JUN2007 APVD B. WERTZ 21JUN2007		Tyco Electronics Harrisburg, PA 17105-3608	
MATERIAL: - FINISH: -		PRODUCT SPEC: 108-2364 APPLICATION SPEC: 114-13120		NAME: SFP+ 1X4 CAGE ASSEMBLY PRESS FIT, EXTERNAL EMI SPRINGS WITH LIGHT PIPES		SIZE: CAGE CODE: DRAWING NO: A100779C=2007178 RESTRICTED TO: -	
CUSTOMER DRAWING		WEIGHT: -		SCALE: 5:1		SHEET: 2 OF 4 REV: A	

LOC	DIST	REV	DATE	BY	APPD
GP	00				

REV	DESCRIPTION	DATE	BY	APPD
-	SEE SHEET 1	-	-	-

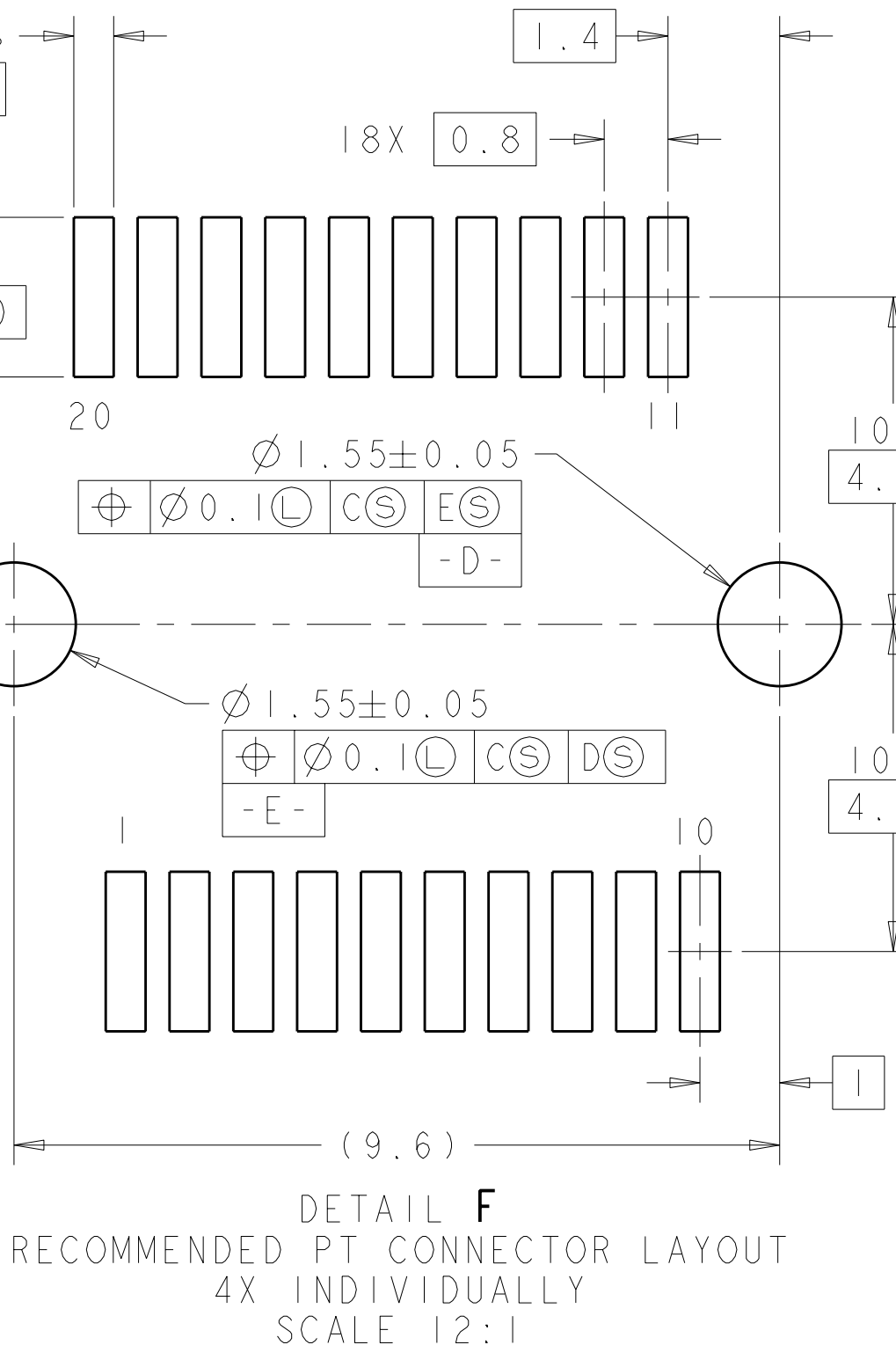
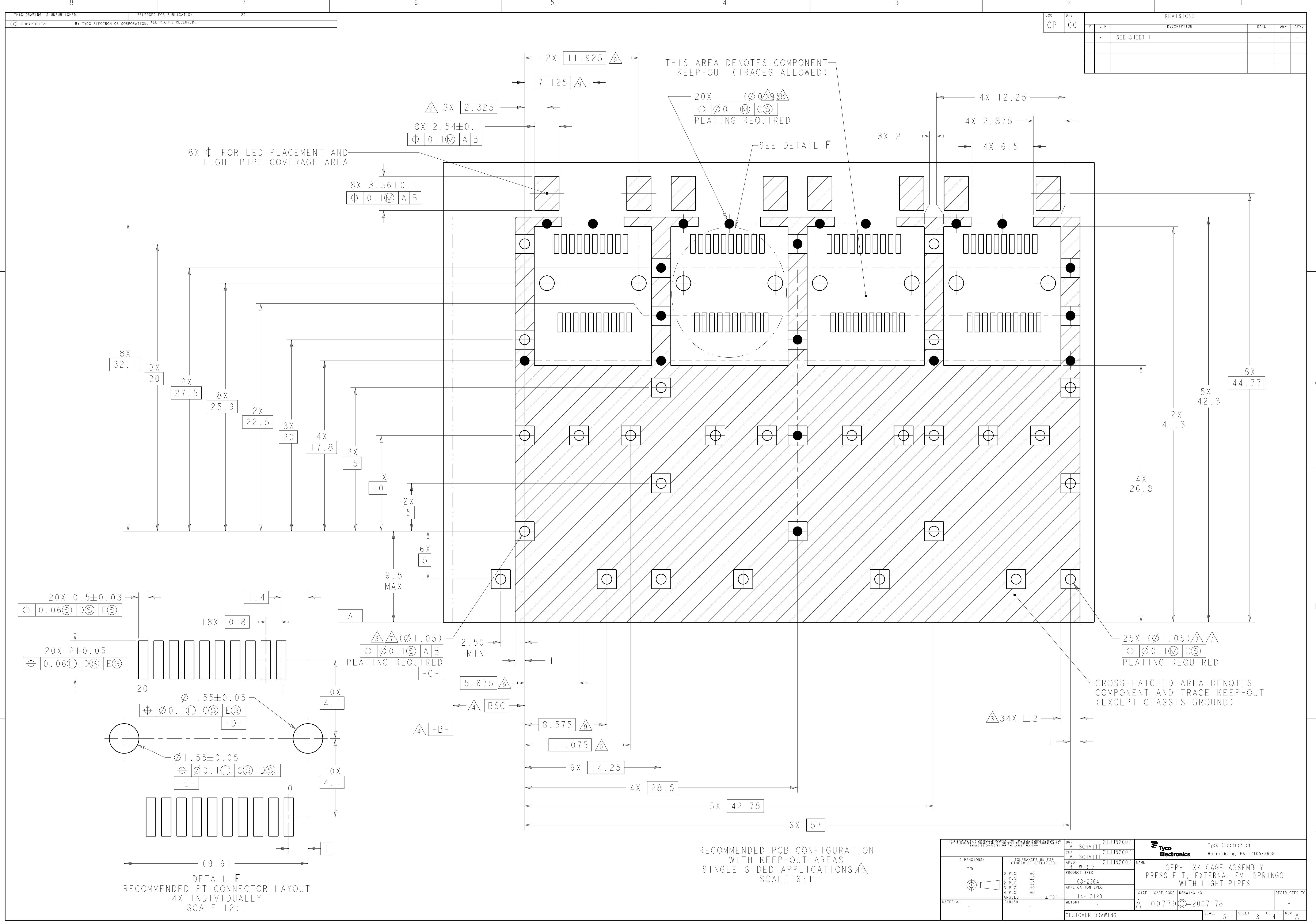

RECOMMENDED PCB CONFIGURATION
 WITH KEEP-OUT AREAS
 SINGLE SIDED APPLICATIONS
 SCALE 6:1

DIMENSIONS: mm		TOLERANCES UNLESS OTHERWISE SPECIFIED: 9 PLC ±0.1 1 PLC ±0.1 2 PLC ±0.1 3 PLC ±0.1 4 PLC ±0.1 ANGLES ±1°		DWN: M. SCHMITT 21JUN2007 CHK: M. SCHMITT 21JUN2007 APVD: B. WERTZ 21JUN2007		Tyco Electronics Harrisburg, PA 17105-3608	
MATERIAL:		FINISH:		NAME: SFP+ 1X4 CAGE ASSEMBLY PRESS FIT, EXTERNAL EMI SPRINGS WITH LIGHT PIPES		SIZE: CAGE CODE: DRAWING NO: A100779C=2007178 RESTRICTED TO:	
CUSTOMER DRAWING		SCALE: 5:1		SHEET: 3 OF 4		REV: A	

LOC	DIST	REV	DATE	BY	APPD
GP	00				

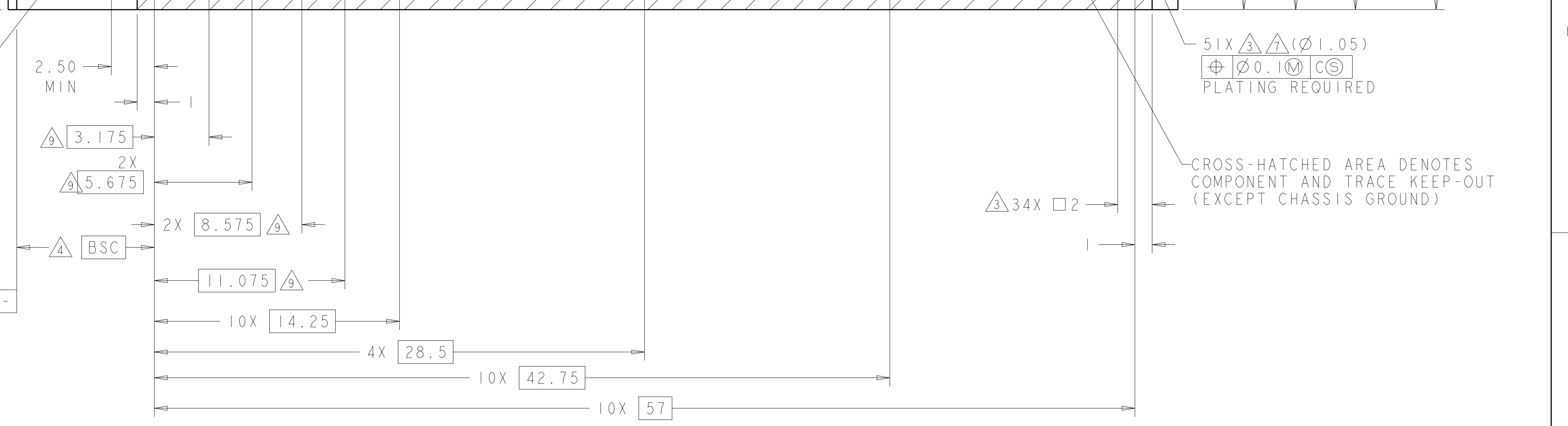
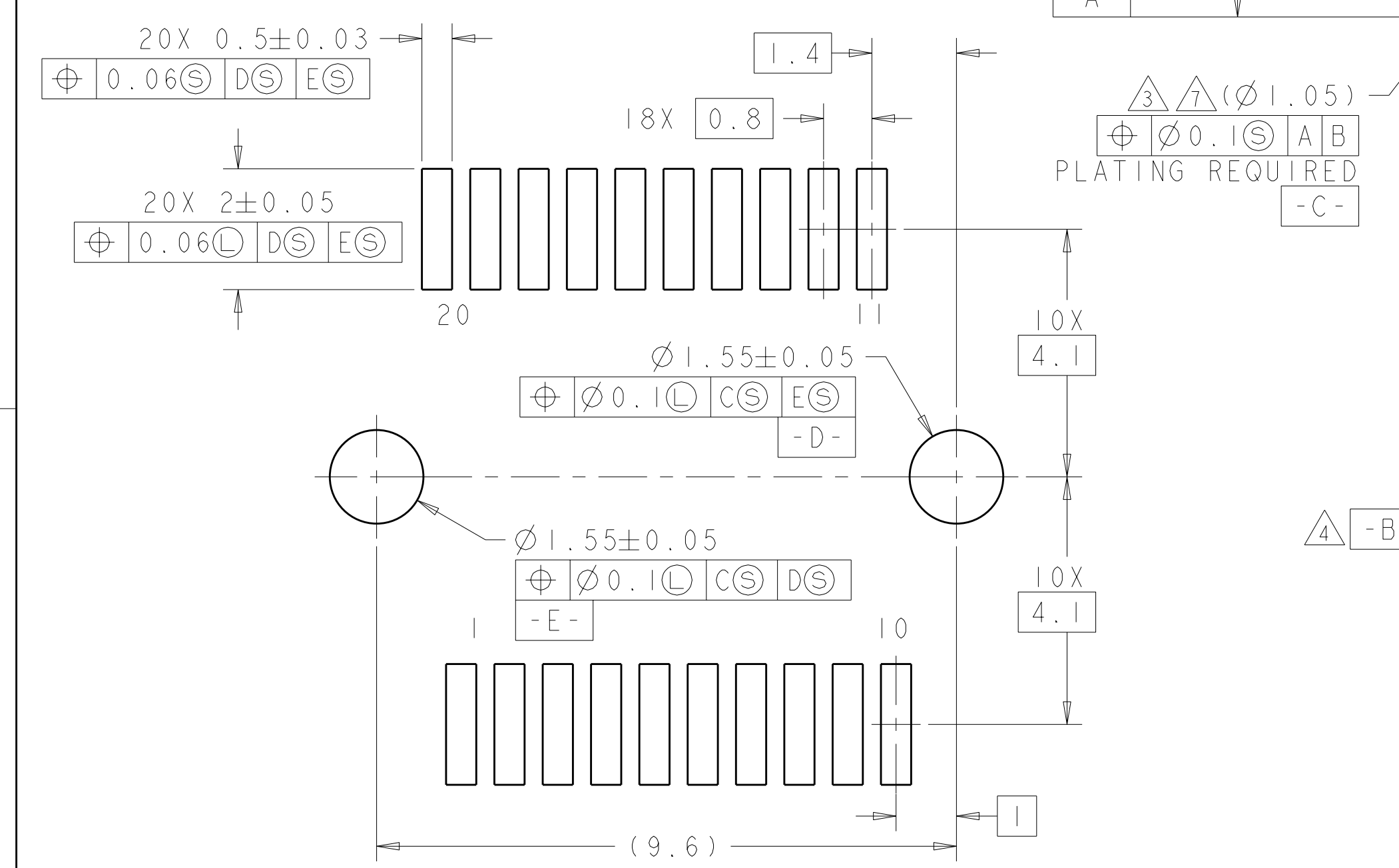
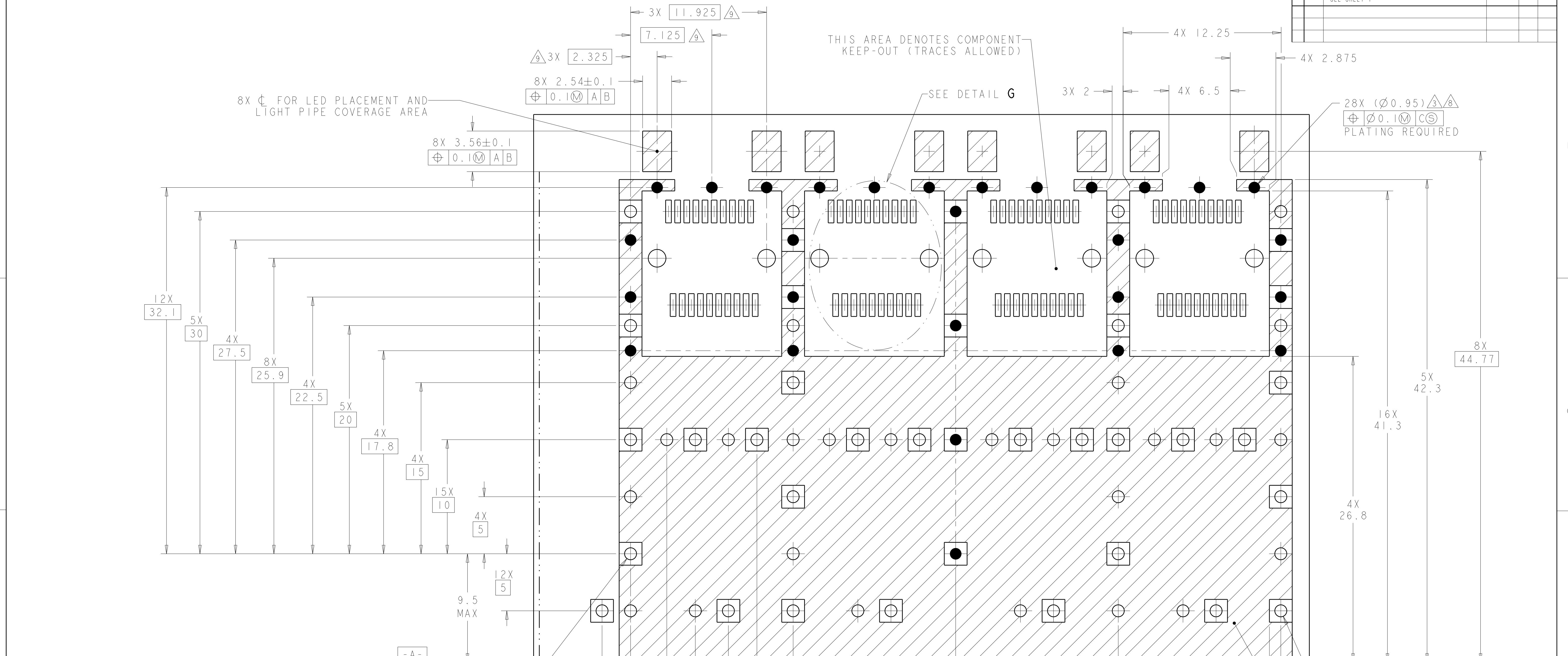

THIS AREA DENOTES COMPONENT KEEP-OUT (TRACES ALLOWED)

SEE DETAIL G

CROSS-HATCHED AREA DENOTES COMPONENT AND TRACE KEEP-OUT (EXCEPT CHASSIS GROUND)

RECOMMENDED PCB CONFIGURATION WITH KEEP-OUT AREAS BELLY TO BELLY APPLICATIONS SCALE 6:1

DIMENSIONS: mm 		TOLERANCES UNLESS OTHERWISE SPECIFIED: 9 PLC ±0.1 1 PLC ±0.1 2 PLC ±0.1 3 PLC ±0.1 4 PLC ±0.1 ANGLES ±1°		DWN: M. SCHMITT 21JUN2007 CHK: M. SCHMITT 21JUN2007 APVD: B. WERTZ 21JUN2007 PRODUCT SPEC: 108-2364 APPLICATION SPEC: 114-13120 WEIGHT: - CUSTOMER DRAWING		Tyco Electronics Harrisburg, PA 17105-3608 NAME: SFP+ 1X4 CAGE ASSEMBLY PRESS FIT, EXTERNAL EMI SPRINGS WITH LIGHT PIPES SIZE: CAGE CODE DRAWING NO: A100779C=2007178 SCALE: 5:1 SHEET 4 OF 4 REV A	
--------------------	--	--	--	--	--	---	--