

LOC	DIST	REV	DATE	BY	APPD
GP	00	A	14MAY2008	ZMR	DLG

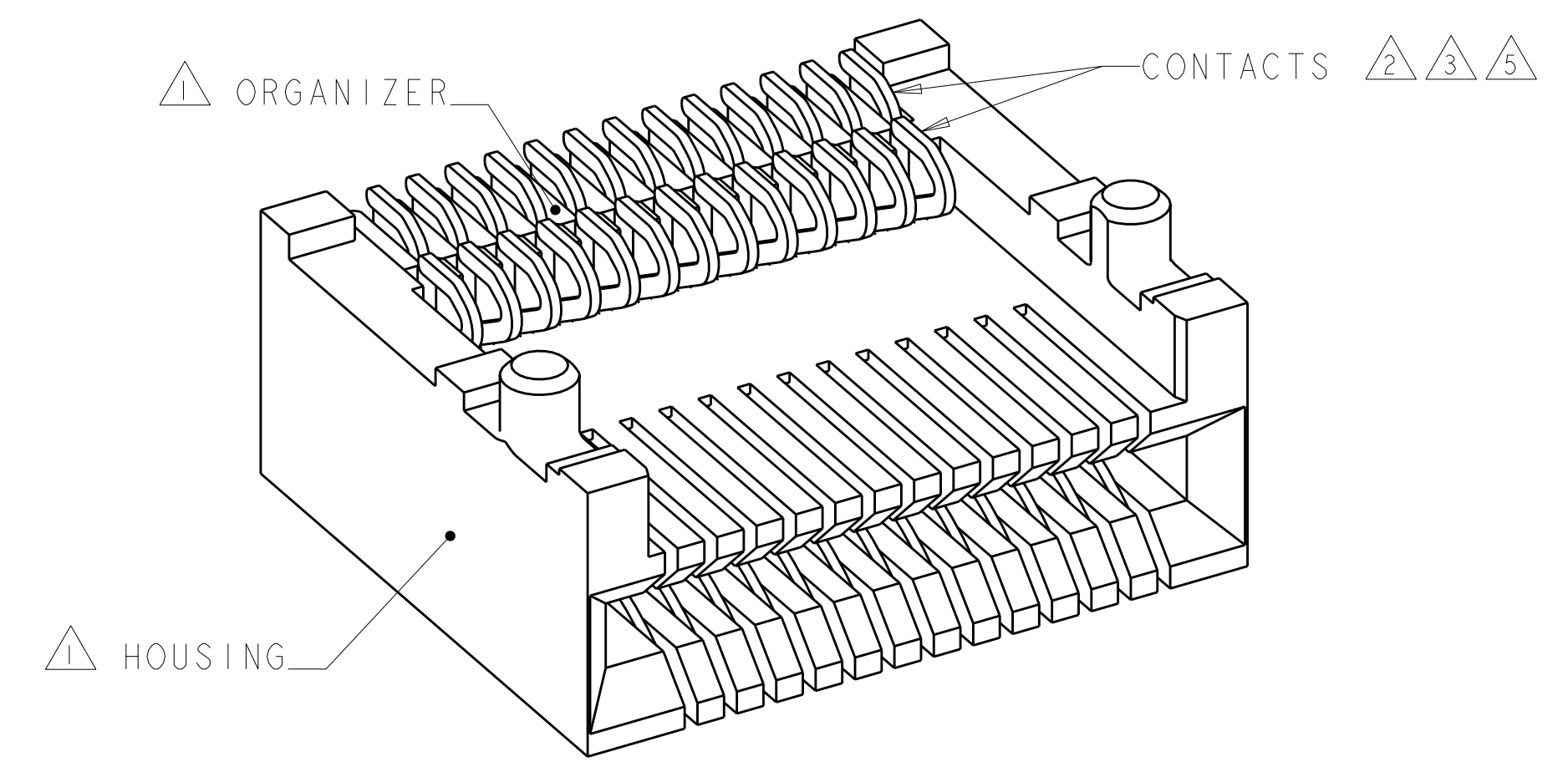

26 POSITION RECEPTACLE
 SCALE 9:1

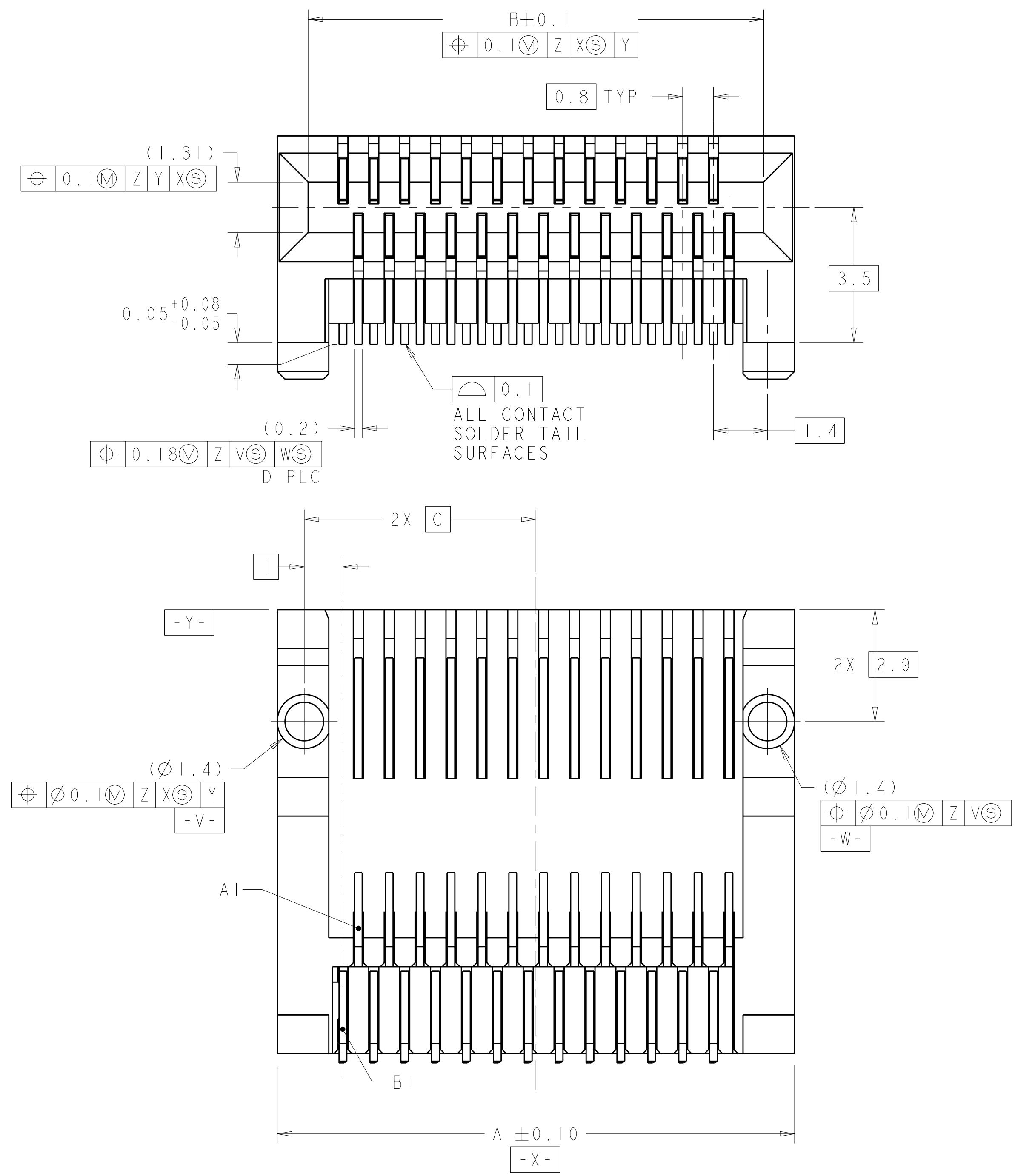

- 1 MATERIAL: LCP, BLACK.
- 2 MATERIAL: PHOSPHOR BRONZE PER ASTM B 103.
- 3 FINISH: 0.76µm MIN GOLD PLATE PER ASTM B 488, APPLIES TO INTERFACE AREA AND 2.03µm MIN TIN PLATE SOLDER TAILS, ALL OVER 3.81µm MIN NICKEL PLATE PER QQ-N-290.
- 4 DATUM AND BASIC DIMENSION ESTABLISHED BY CUSTOMER.
- 5 FINISH: 0.38µm MIN GOLD PLATE PER ASTM B 488, APPLIES TO INTERFACE AREA AND 2.03µm MIN TIN PLATE SOLDER TAILS, ALL OVER 3.81µm MIN NICKEL PLATE PER QQ-N-290.

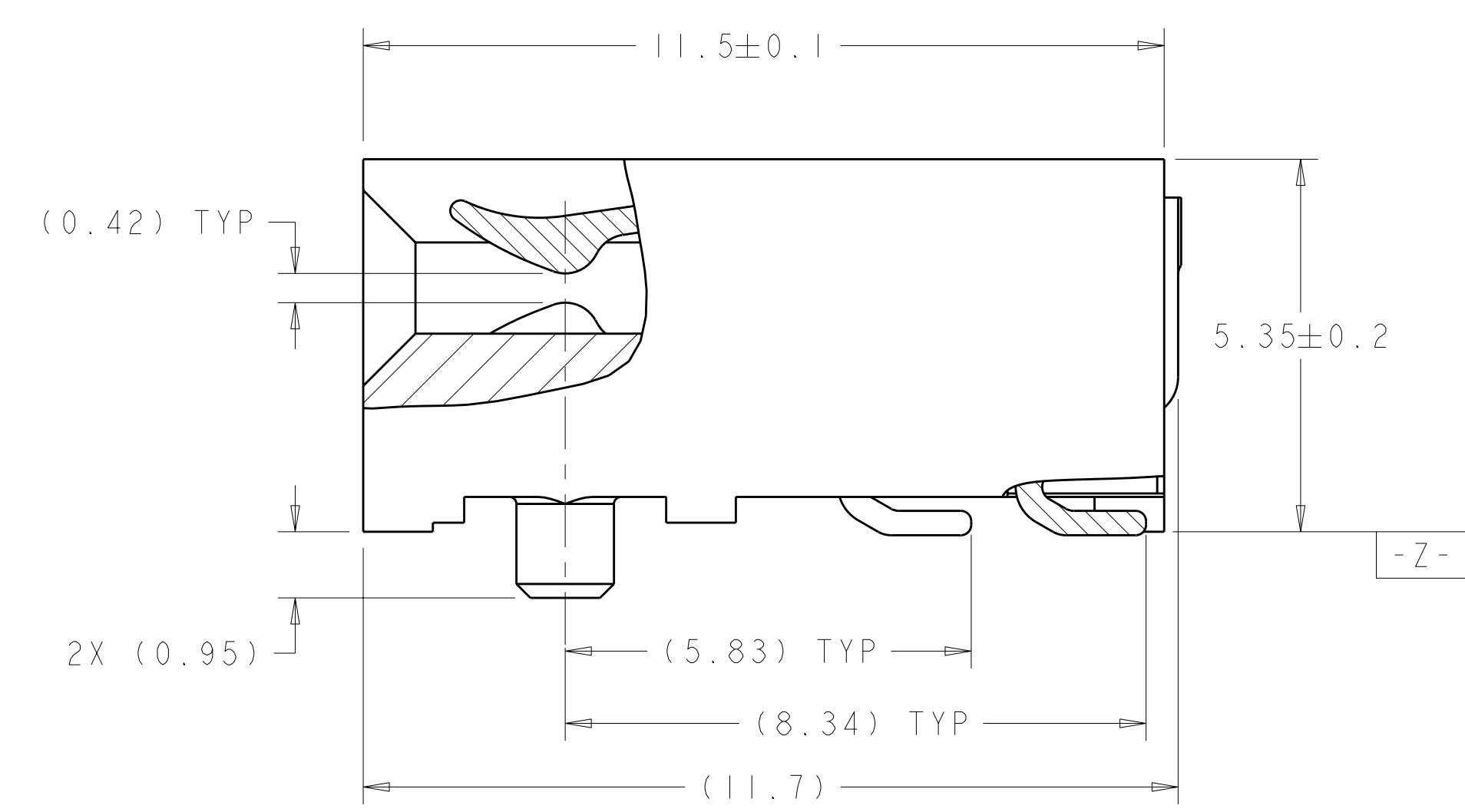

FINISH	PACKAGING	SIZE					POSN	PART NUMBER
		E	D	C	B	A		
1	TAPE AND REEL	16.80	38	8.40	16.60	18.10	38	1-1761987-8
		16.00	36	8.00	15.80	17.40	36	1-1761987-7
		12.00	26	6.00	11.80	13.40	26	1-1761987-6
	TUBE	28.80	68	14.80	28.60	30.20	68	1-1761987-5
		16.80	38	8.40	16.60	18.10	38	1-1761987-4
		23.20	54	11.60	23.00	24.60	54	1-1761987-3
2	TAPE AND REEL	21.60	50	10.80	21.40	23.00	50	1-1761987-2
		16.00	36	8.00	15.80	17.40	36	1-1761987-1
		12.00	26	6.00	11.80	13.40	26	1-1761987-0
	TUBE	16.80	38	8.40	16.60	18.10	38	1761987-9
		16.00	36	8.00	15.80	17.40	36	1761987-8
		12.00	26	6.00	11.80	13.40	26	1761987-7
3	TAPE AND REEL	28.80	68	14.80	28.60	30.20	68	1761987-6
		16.80	38	8.40	16.60	18.10	38	1761987-5
		23.20	54	11.60	23.00	24.60	54	1761987-4
	TUBE	21.60	50	10.80	21.40	23.00	50	1761987-3
		16.00	36	8.00	15.80	17.40	36	1761987-2
		12.00	26	6.00	11.80	13.40	26	1761987-1

DIMENSIONS: mm
 TOLERANCES UNLESS OTHERWISE SPECIFIED:
 9 PLC ±
 5 PLC ±
 4 PLC ±
 ANGLES ±
 MATERIAL SEE NOTES
 FINISH SEE TABLE
 DWN M. E. COWHER 28JUN2005
 CHK R. R. HENRY 28JUN2005
 APPD R. R. HENRY 28JUN2005
 NAME EVERCLEAR Mini-SAS RECEPTACLE CONNECTOR ASSEMBLY, RIGHT ANGLE, SURFACE MOUNT
 PRODUCT SPEC 108-2234
 APPLICATION SPEC
 WEIGHT
 CUSTOMER DRAWING
 Tyco Electronics Harrisburg, PA 17105-3608
 SIZE CAGE CODE DRAWING NO. RESTRICTED TO
 A 100779 C=1761987
 SCALE 12:1 SHEET 1 OF 2 REV A

LOC	DIST	REVISIONS					
GP	00	P	LTB	DESCRIPTION	DATE	DWN	APVD
		-	-	SEE SHEET 1	-	-	-

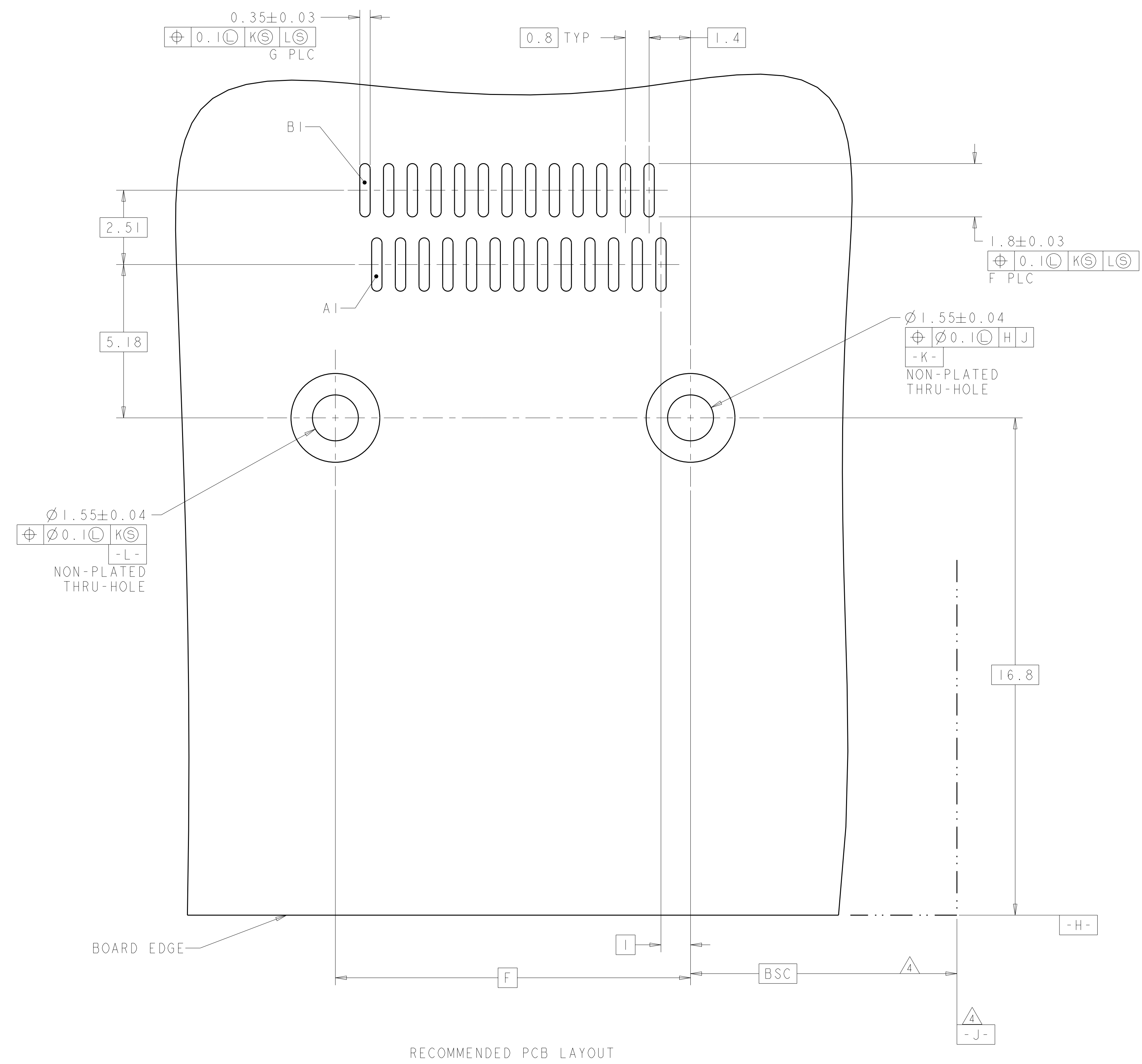

RECOMMENDED PCB LAYOUT

<small>THIS DRAWING IS UNPUBLISHED. RELEASED FOR PUBLICATION BY TYCO ELECTRONICS CORPORATION. IT IS SUBJECT TO CHANGE WITHOUT NOTICE AND WITHOUT OBLIGATION. SHOULD BE CONTACTED FOR THE LATEST REVISION.</small>		DWN M.E. COWHER 28JUN2005 CHK R.R. HENRY 28JUN2005 APVD R.R. HENRY 28JUN2005	Tyco Electronics Harrisburg, PA 17105-3608
DIMENSIONS: mm 	TOLERANCES UNLESS OTHERWISE SPECIFIED: 9 PLC ± 8 PLC ± 5 PLC ± 4 PLC ± ANGLES ± FINISH ±	NAME EVERCLEAR Mini-SAS RECEPTACLE CONNECTOR ASSEMBLY, RIGHT ANGLE, SURFACE MOUNT PRODUCT SPEC 108-2234 APPLICATION SPEC SIZE CAGE CODE DRAWING NO. RESTRICTED TO A 100779 C-1761987	SCALE 12:1 SHEET 2 OF 2 REV A
MATERIAL	FINISH	WEIGHT	CUSTOMER DRAWING