

IN PROCESS 1

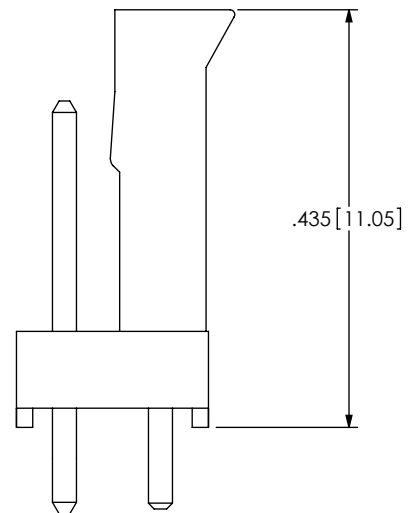

IN PROCESS 2

1. LOAD FULL STRIP RTSW-50-D WITH T-1S6-07-XX-2 AND C-15-02-XX TO DIMENSIONS SHOWN ON INPROCESS 1.
2. MULTI-CUT RTSW-50-D ASSEMBLY TO POSITION.
3. ROTO-CUT LST-50-S BODY TO POSITION.
4. MOUNT LST-XX-S TO RTSW-XX-D TO DIMENSION SHOWN ON INPROCESS 2.

PROPRIETARY NOTE

THIS DOCUMENT CONTAINS INFORMATION CONFIDENTIAL AND PROPRIETARY TO SAMTEC, INC. AND SHALL NOT BE REPRODUCED OR TRANSFERRED TO OTHER DOCUMENTS OR DISCLOSED TO OTHERS OR USED FOR ANY PURPOSE OTHER THAN THAT WHICH IT WAS OBTAINED WITHOUT THE EXPRESSED WRITTEN CONSENT OF SAMTEC, INC.

DO NOT SCALE DRAWING

SHEET SCALE: 5:1

samtec

520 PARK EAST BLVD, NEW ALBANY, IN 47150
 PHONE: 812-944-6733 FAX: 812-948-5047
 e-Mail: info@SAMTEC.com code: 55322

DESCRIPTION:
 .100 C.L. TERMINAL / SOCKET COMBO

DWG. NO.
LST-1XX-XX-XX-D

BY: KEVIN B 10/20/00 SHEET 2 OF 2