

G9A @%\$!\$&\$" \$!LL!8!K HG<C K B

89G B98 / 8A 9BGCB98
B'A @A 9HFGGB7 <9G

G9A @%L!LL!LL" L!LL!8!K HLL

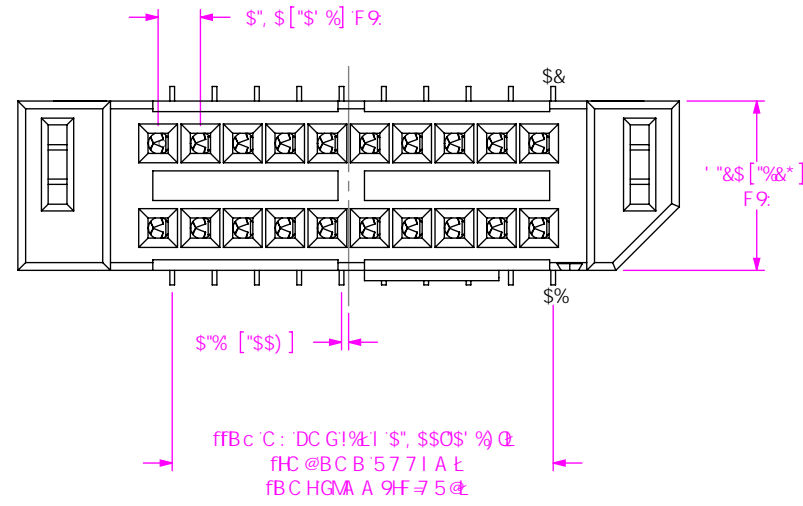

Bc C: DC GHCBG
!\$) HkFl 1) \$ fd9f FCK L
fB) DC G-B 7 F9A 9BH L

@58 GHM
!\$& G F: 57 9A C I BH

G57? <9 <H
!\$ " \$ " ' A A

C DHC B
!H' H5 D9 / F99@
!?. DC @A 89: @A
"fl G9?!) \$!\$ '\$Z G99: ÷ " & z G<H&L

C DHC B
!K H' K 9@B H5 6 fG99: ÷ " & z G<99H&L

D@HB: GD97 ÷ 7.5 HC B
!< . < 95 J M " \$\$\$\$ \$: C @ C B
" 7 C B H 5 7 H : C @ : @ G < C B H 5 @
! : : C @ Z " \$\$\$\$ \$: C @ C B 7 C B H 5 7 H
! : : C @ : @ G < C B H 5 @
! : : @ G < Z " \$\$\$\$ \$ C B 9 B H F 9 7 C B H 5 7 H

FCK 'GD97 ÷ 7.5 HC B
!8. 8 C I 6 @ FCK

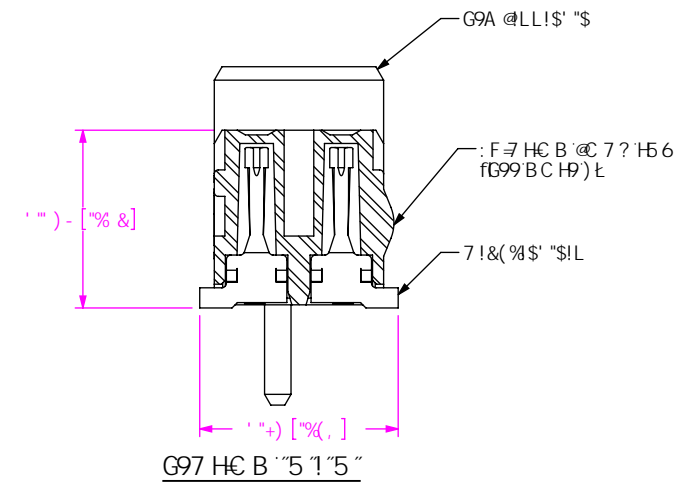
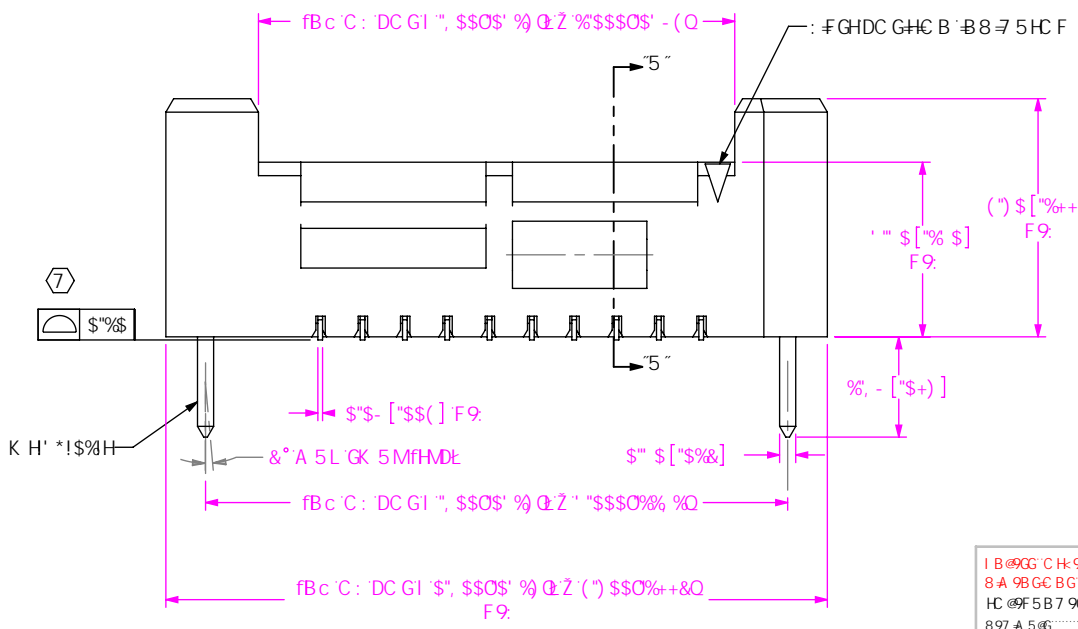

<p>I B @9G C H 9FK 4G GD97 = 98Z 8 A 9B GC BG 5 F 9 B A @A 9HFG HC @F 5 B 7 9G 5 F 9. 897 A 5 @ 5 B : @G L'L . ± \$ " O S % O & * L'LL . ± \$ % O S \$) O L'LL . ± \$ \$) % O S \$ & S Q</p>	<p>DFC DF 9H5 FMBC H H: 68 C 71 A 98 H 7 C B H 6 B G B : C F A 5 H C B 7 C B : 6 9 B H 5 @ 5 B 8 D F C D F 9 H 5 F M C G 5 A H 7 Z B 7 * 5 B 8 G : 5 @ B C H 6 9 F 9 D F C 8 I 7 9 8 C F H 5 B G 9 F 9 8 H C C H 9 F B C 71 A 9 B H C F 8 4 7 @ C 9 8 H C C H 9 F G C F I 9 8 : C F 5 B M D I F D C 9 C H 9 F H 5 B H 5 H K < 7 < H K 5 G C 6 H 8 9 8 K H C I H H 9 9 L D F 9 9 9 8 K F H 9 8 7 C B 9 8 H C : G 5 A H 7 Z B 7 *</p>	 <p>) & \$ D 5 F ? 9 5 G H 6 @ 8 Z B 9 K . 5 @ 5 B M Z B (+) \$ D < C B 9 : % B - ((1 * + 5 L : , % B - (, 1) \$ (+ Y I A U J :) z : 4 G 5 A H 7 " v : a " v X Y .)) & "</p>
<p>A 5 H F 5 @ 8 C ' B C H G 7 5 @ 9 8 F 5 K B : G 9 9 H G 7 5 @ 9 % \$ % (&) + B G @ H C F : J 9 7 H 5 9 % \$) 7 C B H 5 7 H , &) 6 Y 71 Z < 5 @ < 5 F 8 @ C 7 ? B : 7 @ D . D < C G 6 F C B N 9) % \$ K 9 @ B H 5 6 . 6 F 5 G 5 @ C K & ' S 2 : I @ @ < 5 F 8</p>	<p>89G7 F DHC B. " , A A H 9 F 9 M 9 A 7 F C ' G C 7 ? 9 H 8 K : " B C " G9A @%L!LL!LL" L!LL!8!K HLL 6M 8 " G 7 < A 9 @N , # & \$ # & \$ \$, G < 9 9 H % C : &</p>	

