

DRAWING MADE IN THIRD ANGLE PROJECTION

THIS DRAWING IS UNPUBLISHED. RELEASED FOR PUBLICATION .19
 © COPYRIGHT 19 BY AMP INCORPORATED, HARRISBURG, PA. ALL INTERNATIONAL RIGHTS RESERVED. AMP PRODUCTS MAY BE COVERED BY U.S. AND FOREIGN PATENTS AND/OR PATENTS PENDING.

LOC	DIST	P	F	ZONE	LTR	REVISIONS	DATE	APPD
CM	53					C REDWN/REV PER CM-586	8-28-86	KJ/RS
						D REV PER ECN CM-1046	6-3-87	RS

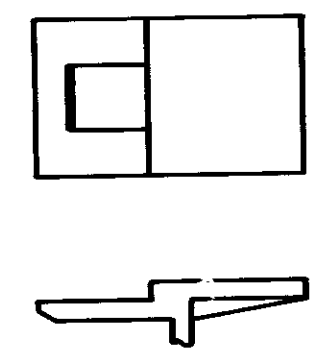
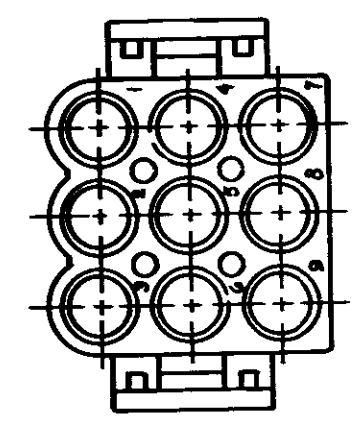
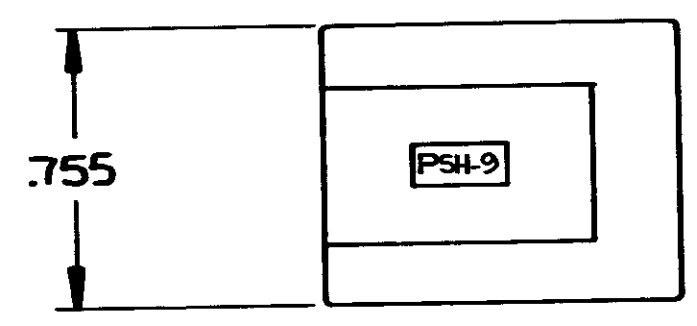
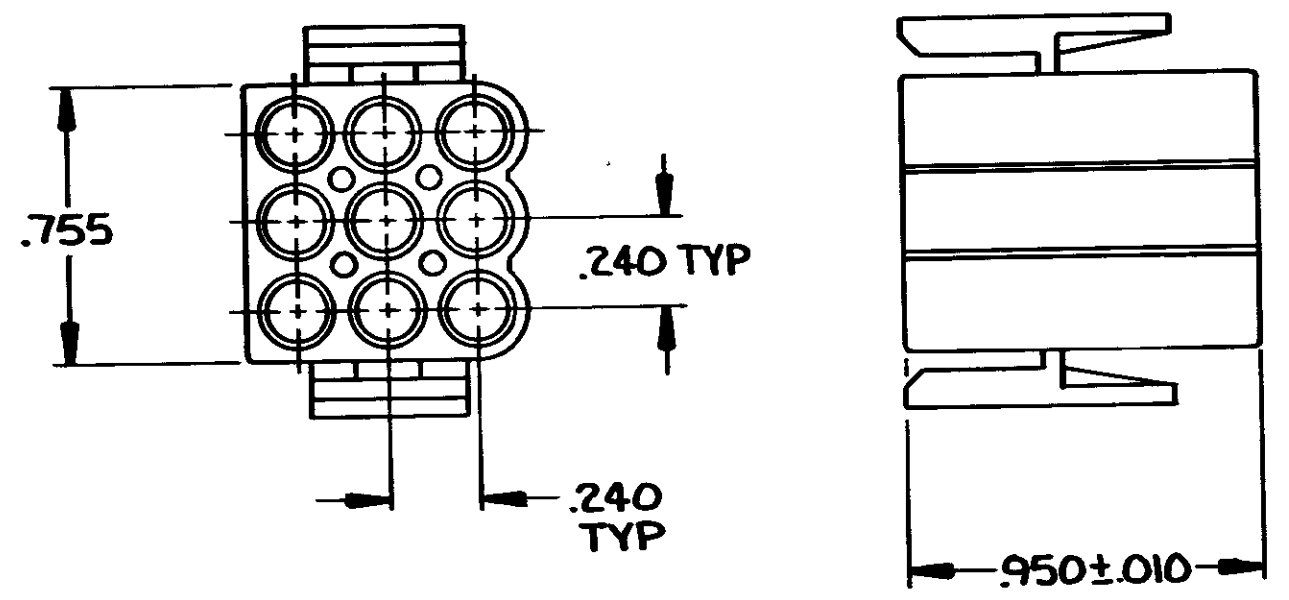

OPTIONAL CONSTRUCTION

1. USE WITH CAP 480586.
2. ACCEPTS SOCKET 61626.

1-480585-0
PART NO

UNLESS OTHERWISE SPECIFIED DIMENSIONS ARE IN INCHES TOLERANCES ON 2 PL DEC ± _____ 3 PL DEC ± .005 ANGLES ± _____		DR <i>Whitaker 8-28-86</i> CHK <i>R. Swing 9-2-86</i> APPD <i>M. Swate 9-2-86</i> APPD		AMP AMP INCORPORATED Harrisburg, Pa. 17105	
MATERIAL NYLON UL94V-2		PRODUCT SPEC _____		NAME PLUG, 9 CIRCUIT, .140 MATE-N-LOK	
COLOR NATURAL		APPLICATION SPEC _____		SIZE C	FSCM NO 00779
WEIGHT _____		DRAWING NO 480585		SHEET 1 OF 1	

CUSTOMER DRAWING