

THIS DRAWING IS UNPUBLISHED. RELEASED FOR PUBLICATION, 19
 BY AMP INCORPORATED. ALL RIGHTS RESERVED.

LOC	DIST	REVISIONS					
		P	LTR	DESCRIPTION	DATE	DWN	APVD
AD	39		J	REV PER 0010-0478-94	11-94	EB	SAS
			K	REV PER 0010-1784-94	3-6-95	EB	SAS
			L	REV PER 0621-0168-98	25JAN99	BH	BES

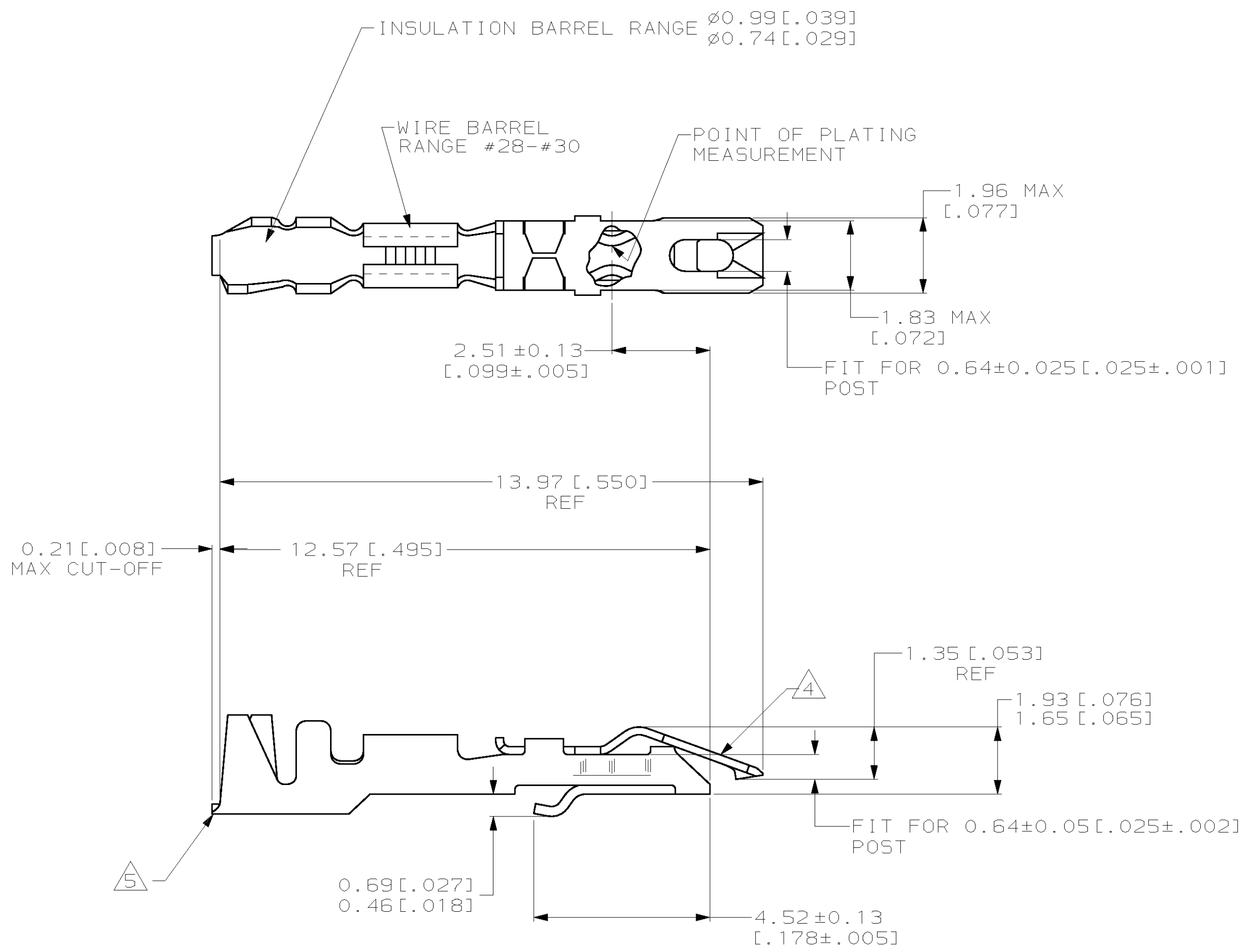

- ① PLATED WITH 0.00076[.000030] GOLD IN CONTACT AREA, GOLD FLASH ON REMAINDER, OVER 0.00127[.000050] NICKEL.
- ② PLATED WITH 0.00254[.000100] TIN-LEAD OVER 0.00127[.000050] NICKEL - ENTIRE CONTACT.
- ③ PLATED WITH 0.00127[.000050] GOLD OVER 0.00127[.000050] NICKEL - ENTIRE CONTACT.
- ④ SPRING MATERIAL: STAINLESS STEEL.
- ⑤ BODY MATERIAL: PHOS BRONZE - FINISH: SEE TABLE.

OBSOLETE	③	87191-3	87190-3
	②	87191-2	87190-2
	①	87191-1	87190-1
	BODY FINISH	PART NO (LOOSE PIECE)	PART NUMBER (STRIP)

<small>THIS DRAWING IS A CONTROLLED DOCUMENT FOR AMP INCORPORATED. IT IS SUBJECT TO CHANGE AND THE CONTROLLING ENGINEERING ORGANIZATION SHOULD BE CONTACTED FOR THE LATEST REVISION.</small>		DWN	E. BRANDBERG	9-23-94	AMP Incorporated Harrisburg, PA 17105-3608
DIMENSIONS: mm (INCHES)		CHK	S. SHUEY	9-23-94	
TOLERANCES UNLESS OTHERWISE SPECIFIED: 0 PLC ±- 1 PLC ±- 2 PLC ±- 3 PLC ±- 4 PLC ±- ANGLES ±- FINISH ±-		APVD	D. DUPLER	9-23-94	
		PRODUCT SPEC	108-36028	APPLICATION SPEC	
MATERIAL	SEE CALLOUT	WEIGHT	-	114-25006	CONTACT - LOCKING CLIP FOR 0.64[.025] SQUARE POST
		CUSTOMER DRAWING	SCALE	10:1	SIZE A2 CAGE CODE 00779 DRAWING NO C-87191
					SHEET 1 OF 1 REV L