

HONEYWELL PART NUMBER
23AC81
KC-R1633

REV	DOCUMENT	CHANGED BY	CHECK
4	0038160	KVS 24APR08	ASD

PUSH TO OPERATE-RETURNS  
AUTOMATICALLY TO POSITION  
SHOWN

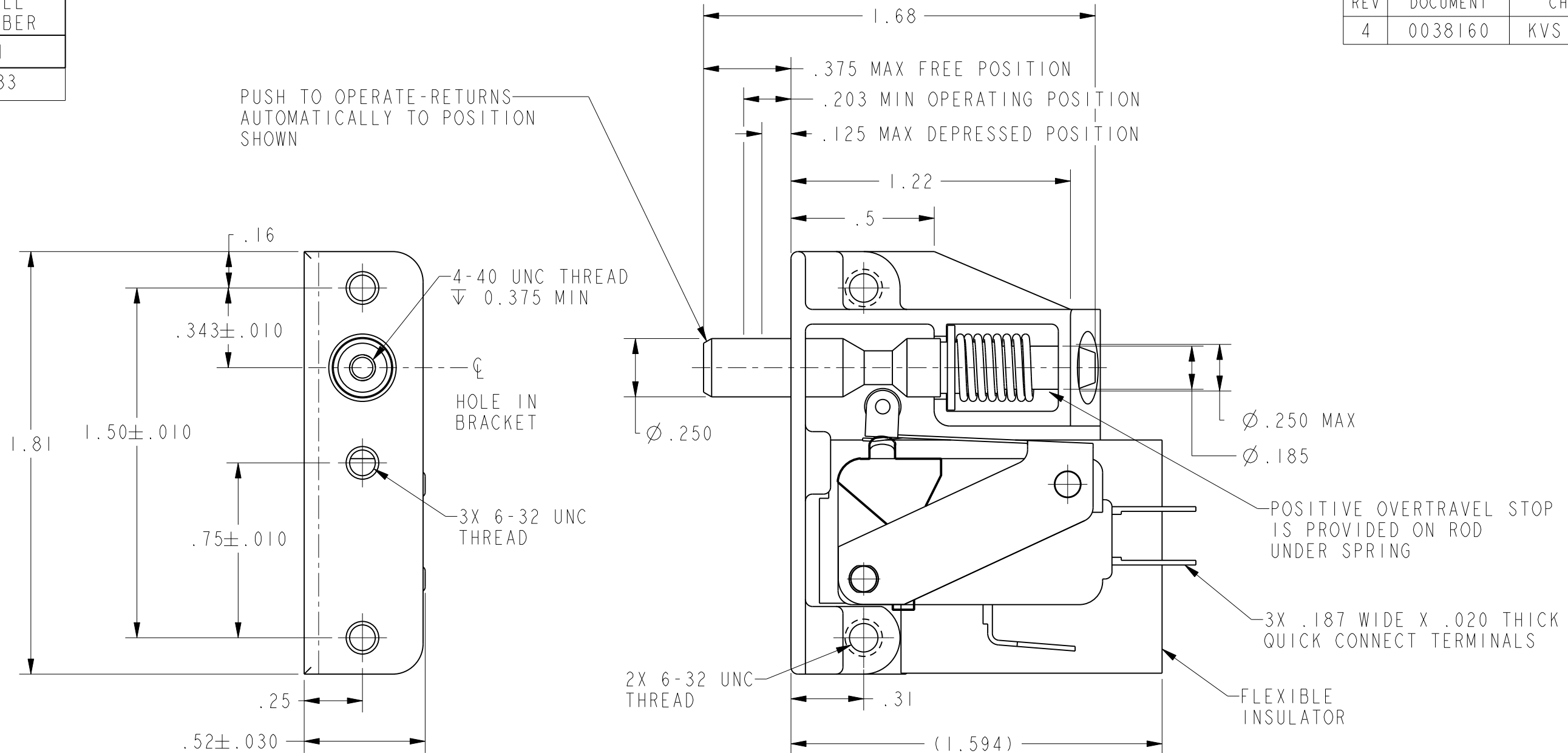

NOTES

1. UNIT INCLUDES CATALOG LISTING "V7-6A17D8-S" BASIC SWITCH
2. BASIC SWITCH PLASTIC PARTS ARE MADE OF GLASS FILLED PCT AND TEFLON FILLED PHENOLIC
3. ACTUATOR ROD MADE OF HIGH STRENGTH PLASTIC
4. NOTCH IN ACTUATOR ROD WILL PERMIT .035 DISPLACEMENT BETWEEN END OF ROD AND HOLE IN BRACKET

CHARACTERISTICS	ELECTRICAL DATA	DESIGN UNITS: INCH	DRAWN	BS	19MAR08	<b>Honeywell</b>						
		TOLERANCES UNLESS NOTED:	CHECK	ASD	19MAR08							
TOTAL TRAVEL: .250 APPROX PUSH DIRECTION	CONTACT ARRANGEMENT S P D T	NO PLACES    x    ±	THIS DRAWING COVERS A PROPRIETARY ITEM AND IS THE PROPERTY OF HONEYWELL. THIS DRAWING IS NOT TO BE COPIED OR USED WITHOUT THE PERMISSION OF HONEYWELL.			TITLE <b>ASSEMBLY-SWITCH</b>						
FULLY DEPRESSED FORCE-- 4 LBS MAX	5A 125, <u>250</u> , 277 VAC 1/10HP <u>250</u> VAC	ONE PLACE    .x    ±    0.030										
		TWO PLACE    .xx    ±    0.015				INTERPRET PER ASME Y14.5M-1994 OTHER HONEYWELL ENGINEERING STANDARDS MAY APPLY			SIZE	TYPE	DRAWING NAME	REV
		THREE PLACE    .xxx    ±    0.005							<b>B</b>	<b>I</b>	<b>23AC81</b>	<b>4</b>
		ANGLES    x    ±	THIRD ANGLE PROJECTION			SCALE	2:1		SHEET	1 OF 1		
						Pro/ENGINEER	3D					