

The information disclosed herein was originated by and is the property of MAZeT. MAZeT reserves all patent, proprietary, design, use, sales, manufacturing and reproduction rights thereto. Product names used in this publication are for identification purposes only and may be trademark of their respective companies.

REVISIONS

| REV: | DISCRIPTION | APPROVED |
|------|-------------|------------|
| 1 | V1.1 | 2001/02/21 |

DATA-SHEET

MCSi

Integral 3-Element Color Sensor

1. FUNCTION

The colour sensors are made of 19 x 3 Si-PIN photo diodes integrated on chip. They are carried out as a hexagonal matrix with the diameter of 3 mm. The design as Si-PIN photo diodes allows signal frequencies up to MHz-range. In order to achieve a small cross talk between the photodiodes the individual sectors were separated from each other by additional structures. Each of these photodiodes is sensitized with dielectric spectral filter for its colour range, preferably for the primary colors red, green and blue.

2. APPLICATION

- Quality control
- Monitoring the production
- Control of manufacturing
- Detection of colour marks

3. FEATURES

Dielectric filters guaranties the good optical properties of the colour sensors, such as:

- high transmission
- slight aging of the filter
- high temperature stability
- high signal frequency
- reduced cross talk
- small size (diameter of the optical sensitive surface ca. 3 mm)
- insensitiveness to decentralized imaging, e. g. LWL coupling

4. CONSTRUCTION

- 3 x 19 on chip integrated PIN photo diodes
- different package versions (TO5 with/without IR-blocking)
- dielectric filters for the three colour ranges: red, green and blue
- Electrical connections
 - three anodes
 - one common cathode

MAZeT GmbH Sales office
 Göschwitzer Straße 32
 D-07745 Jena / Germany
 Phone: +49/3641-2809-0
 Fax: +49/3641-2809-12
 Email: sales@MAZeT.de

| Approvals | Date | MAZeT GmbH | |
|-----------|------------|---------------------|--------------|
| Drawn | 2001/02/21 | Status: Data sheet | |
| Checked: | 2001/02/21 | | |
| Released | 2001/02/21 | DOC. NO: DB-99-070e | Sheet 1 of 4 |

| REVISIONS | | |
|-----------|-------------|------------|
| REV. | DESCRIPTION | APPROVED |
| 1 | V1.1 | 2001/02/21 |

5. MAXIMUM RATINGS / CHARACTERISTICS

(TA = 25°C; per single diode)

| Description | Symbol | Condition | typ. Value | Unit |
|--|--|---|-------------------------------------|-----------------|
| Diameter of the light sensitivity area | D | | 3,0 | mm |
| Light sensitivity area per element | A | | 0,06 | mm ² |
| Photo sensitivity of colour ranges | S _{max} | λ _B = 470 nm λ _G = 570 nm λ _R = 650 nm | 0,26 0,33 0,41 (0,25) | A/W |
| Photo sensitivity per colour | A | | 1,2 | mm ² |
| Field of the spectral sensitivity ± 2%*λ | λ _B λ _G λ _R | | 400 - 510 490 - 610 590 - 750 | nm |
| Reverse Voltage | V _R | | 5 | V |
| Dark current | I _R | V _R = 5V | <100 | pA |
| Terminal Capacitance | C | V _R = 5V | <100 | pF |
| Rise and fall time of the photocurrent | t _r , t _f | | <1 | µs |
| Noise equivalent power | NEP | | <10 ⁻¹³ | W/√Hz |
| Crosstalk | | | 5 | % |
| Angle of incidence | φ | Δλ _(Filter) < 1%*λ | 8 | Grad |
| Operating temperature range | T _{op} | | 0 ... +70 | °C |
| Storage temperature range | T _{st} | | -20 ... +80 | °C |

6. CHARACTERISTIC CURVE

6.1 Typical spectral sensitivity of the integral colour sensor without IR-blocking

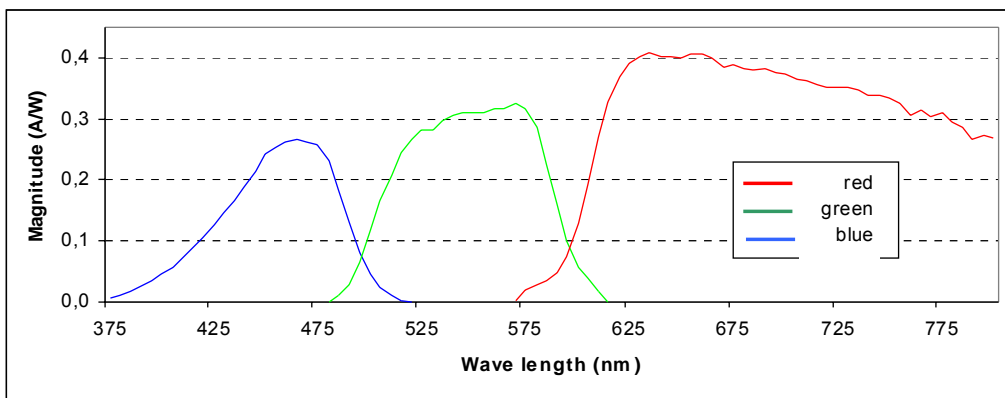

6.2 Typical spectral sensitivity of the integral colour sensor with IR-blocking

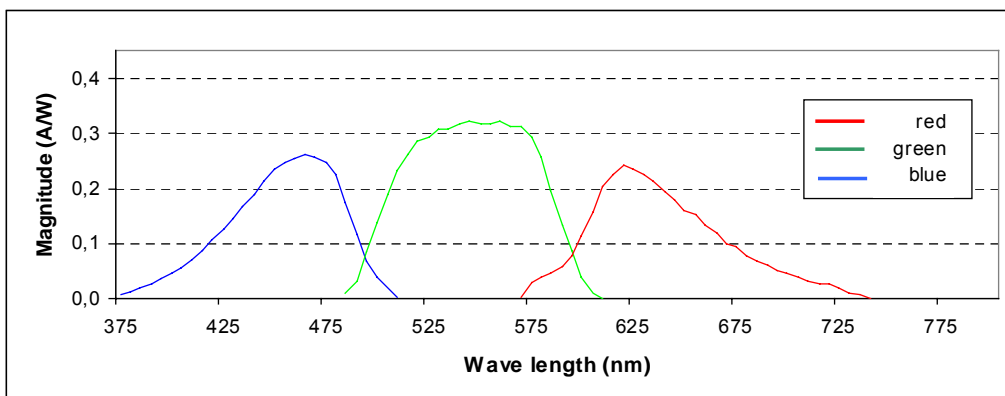

| REVISIONS | | |
|-----------|-------------|------------|
| REV. | DESCRIPTION | APPROVED |
| 1 | V1.1 | 2001/02/21 |

7. PACKAGE OVERVIEW

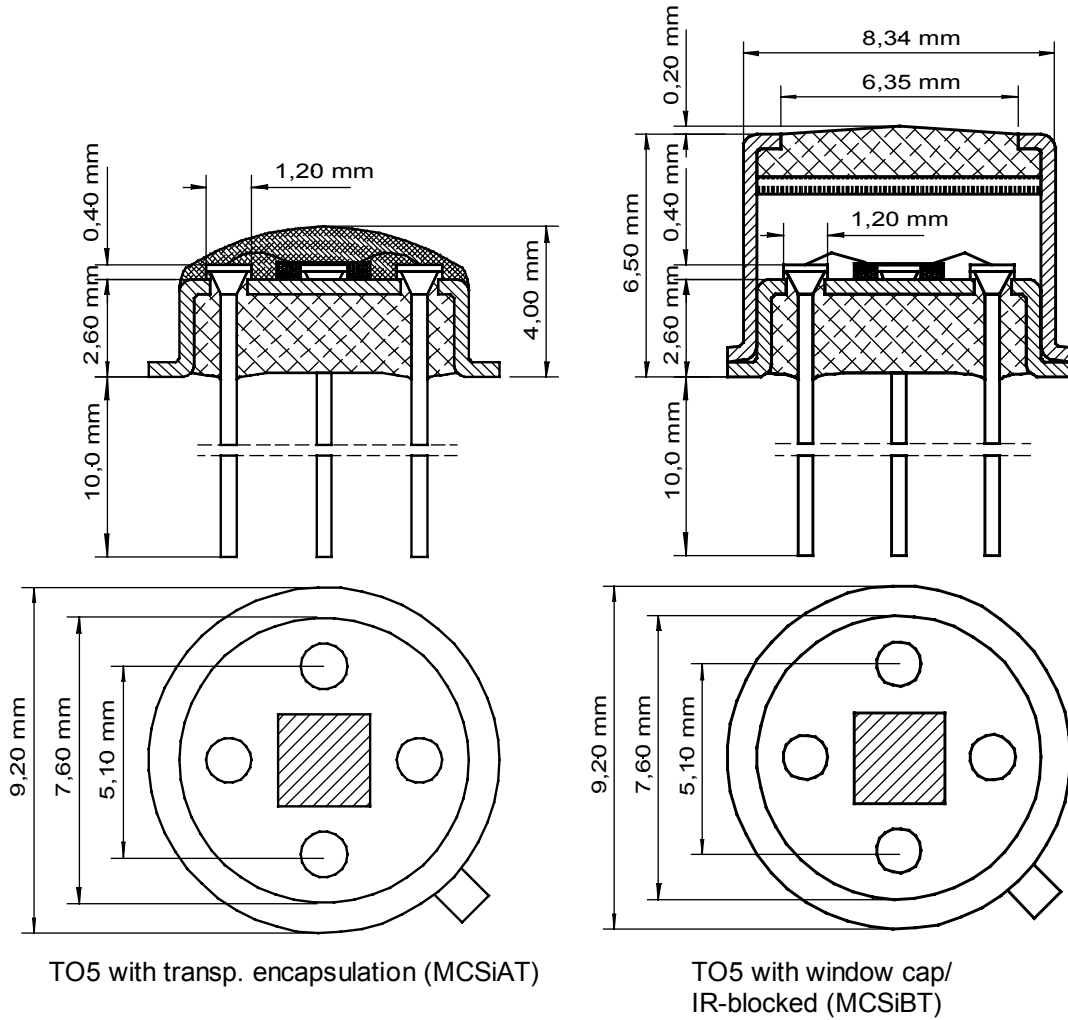

TO5 with transp. encapsulation (MCSiAT)

TO5 with window cap/
IR-blocked (MCSiBT)

| REVISIONS | | |
|-----------|-------------|------------|
| REV. | DESCRIPTION | APPROVED |
| 1 | V1.1 | 2001/02/21 |

8. PIN-CONFIGURATION

(Top view)

| PIN- | description |
|------|----------------|
| A1 | red |
| A2 | blue |
| A3 | green |
| A4 | common cathode |

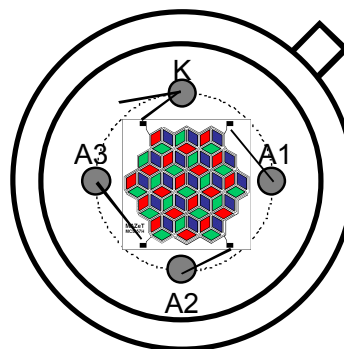

TO5-outline

9. APPLICATION CIRCUIT

Opposite figure shows an circuit for the conversion of photo current to an equivalent voltage. These voltage can be processed e.g. with an ADC. By the selection of suitable resistors the output voltage range can be adjusted to the photo current value. (for example the pin-programmable transimpedance amplifier MT104 with the

$$R_x \approx \frac{V_{Out}}{I_{Photo}}$$

resistors 25kΩ, 500kΩ and 5MΩ)

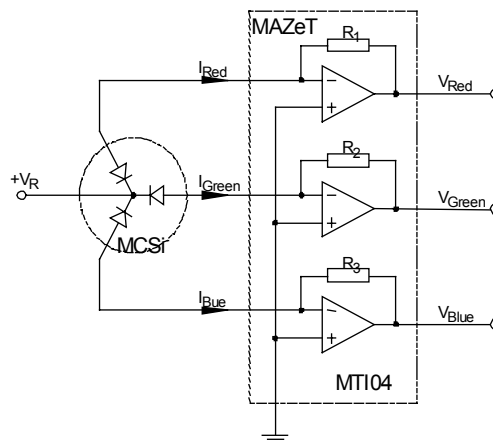

10. APPLICATION NOTE

It is recommended to use an IR-block filter > 720nm or an light source with low infrared radiation for optimal operations of the colour sensor.

11. ORDERING INFORMATION

- integral colour sensor MCSi as Die
- integral colour sensor MCSi with TO5-package + transparent encapsulation
- integral colour sensor MCSi with TO5-package + glas cap IR-blocked
- Evaluation board for JENCOLOUR sensors

MCSiAT
MCSiBT
MCS-EB1