

DPM 970

Digital AC Voltmeter Module

A 3½ digit LCD panel meter, featuring 19mm (0.75") digit height and LED backlighting, the DPM 970 is a true RMS voltage and current meter with 500V a.c. (2kV[Ⓜ]) and 2mA full scale readings as standard. By changing the value of scaling resistors or adding a shunt, this module will measure most a.c. voltages and currents. The DPM 970 features auto-zero and suppression of d.c. offset voltage. The digital hold function freezes the last displayed reading. Calibration is achieved via two multi-turn potentiometers for offset and scale. Connection to the meter is via screw terminals. The module is housed in a robust carrier which can be bolted in place or panel mounted using the bezel, window and clips provided.

- 🔊 19mm (0.75") Digit Height
- 🔊 Screw Terminal Connections
- 🔊 Digital Hold
- 🔊 500V a.c. (2kV[Ⓜ]) Full Scale Reading
- 🔊 Measures Voltage and Current
- 🔊 LED Backlighting

SCALING

The value of the three scaling resistors RA1, RA2 and RB may be altered in order to change the full scale reading (F.S.R.) of the meter - see table. To ensure that the meter reads "000" with zero input voltage/current, short circuit ACV and COM and adjust the ZERO potentiometer. The meter will need re-calibration by adjusting the CAL potentiometer.

Required F.S.R.	RA1	RA2	RB
200mV ①	0R	0R	Open
2V ①	910k	0R	100k
20V ①	1M	0R	10k
200V ①	1M	0R	1k
2kV (factory default) ① ②	464K	536K	100R
2mA (factory default) ③	-	-	100R
20mA ③	-	-	10R
200mA ③	-	-	1R
2A ③	-	-	0.1R
20A ③ ④	-	-	0.01R

NOTE

- ① Use inputs ACV and COM for measuring voltage.
- ② For measuring voltages above 500V RMS, external scaling resistors must be used.
- ③ Use inputs ACI and COM for measuring current.
- ④ We recommend the use of a current transformer when measuring in excess of 10 Amps. Consult current transformer manufacturer's data for connections and recommendations.

Other scaling factors can be achieved via the correct selection of RA1, RA2 and RB values.



Standard Meter	Min.	Typ.	Max.	Stock Number
Specification				DPM 970
Accuracy (overall error) *		0.5	1.5	% (±2 count)
Full scale reading **	0		1999	V _{RMS}
Resolution		1		V _{RMS}
Sample rate		3		samples/sec
Operating temperature range	0		50	°C
Temperature stability		200		ppm/°C
Frequency range (input voltage)	15		15k	Hz
Input impedance (2kV range)		1		MΩ
DC Supply voltage	7.5	9	14	V d.c.
Supply current (Backlighting off)		1.5		mA d.c.
Supply current (Backlighting on) @ 5Vd.c.		50		mA d.c.

* To ensure maximum accuracy, re-calibrate periodically.

** Maximum safe input voltage across the ACV and COM terminals is 500V_{RMS}.

If voltages to be measured exceed 500V_{RMS}, then fit scaling resistors externally to the module.

DIMENSIONS All dimensions in mm (inches)

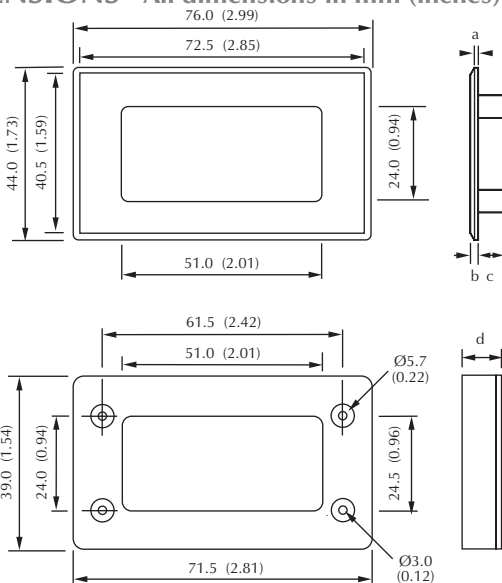

- a. 1.0 (0.04)
- b. 2.0 (0.08)
- c. 6.5 (0.26)
- d. 11.5 (0.45)

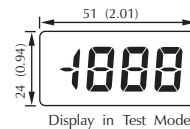

Panel cut-out 72 x 40 (2.83 x 1.57)
Maximum panel thickness 3mm (0.12).

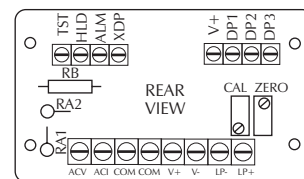

WEBSITE: <http://www.lascarelectronics.com/>

SCREW TERMINAL FUNCTIONS

ACV	Alternating voltage measurement input, accepts up to 500V a.c. By changing the values of scaling resistors RA1, RA2 and RB, other voltage and current ranges can be achieved. To measure in excess of 500V a.c., remove RA1, RA2 and RB from the meter and externally; link RA1 and RA2 on the meter. See scaling table for suitable values for RA1, RA2 and RB.
ACI	Alternating current measurement input. See Scaling table for suitable values for shunt resistor RB.
COM	Return line for voltage measurement input (ACV) or current measurement (ACI) input.
COM	Return line for voltage measurement input (ACV) or current measurement (ACI) input.
V+	Positive power supply input.
V-	Negative power supply input.
LP-	Negative supply for LED backlighting.
LP+	Positive supply for LED backlighting.
TST	Connect to V+ to display all segments except decimal points and annunciators. It should not be operated for more than a few seconds as the DC voltage applied to the LCD may "burn" the display. This connection is normally at 5V below V+ and is the ground for the digital section of the meter.
HLD	Digital Hold option. Connect to V+ to hold last displayed reading indefinitely.
ALM	Alarm "!" annunciator. Connect to XDP to display.
XDP	Annunciator drive waveform. Used to drive alarm annunciator (ALM) if required.
V+	Auxilliary V+ for connections to decimal points DP1, DP2 or DP3.
DP1	199.9 Connect to V+ to display required decimal point.
DP2	19.99 Connect to V+ to display required decimal point.
DP3	1.999 Connect to V+ to display required decimal point.

⚠ SAFETY WARNING ⚠

To comply with the Low Voltage Directive (LVD 93/68/EEC), input voltages to the module's connectors must not exceed 500VRMS. If voltages to be measured exceed 500VRMS, then fit scaling resistors externally to the module. If the mains power supply is connected to the module, then all the module's connectors must be considered to be floating at mains potential. Consequently due caution must be exercised when connecting to the module's connector functions under these conditions. The user must ensure that the incorporation of the DPM into the user's equipment conforms to the relevant sections of BS EN 61010 (Safety Requirements for Electrical Equipment for Measuring, Control and Laboratory Use).

APPLICATIONS

WARNING : Do not apply in excess of 500V a.c. to the meter.

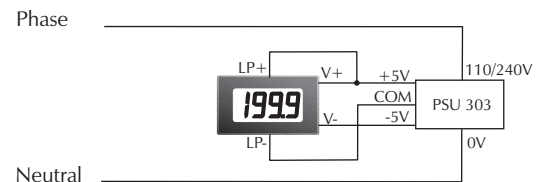
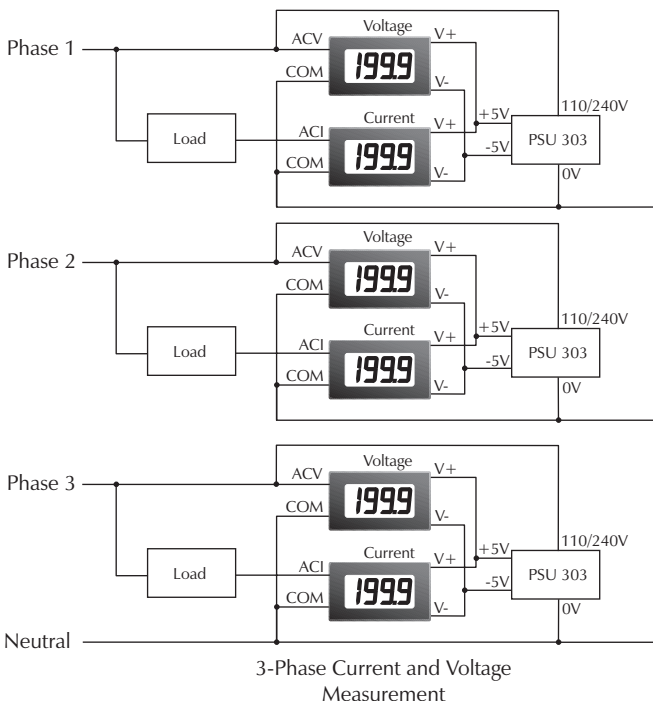

Powering the LED backlighting on a DPM 970 from the PSU 303's +5V and COM outputs.

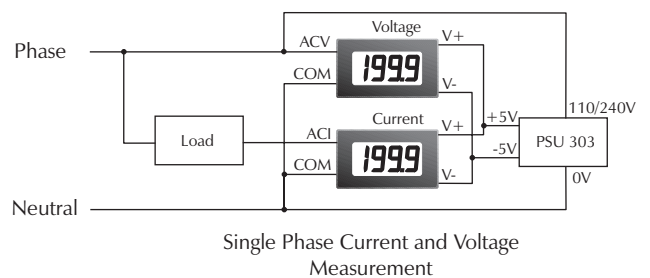

Single Phase Current and Voltage Measurement

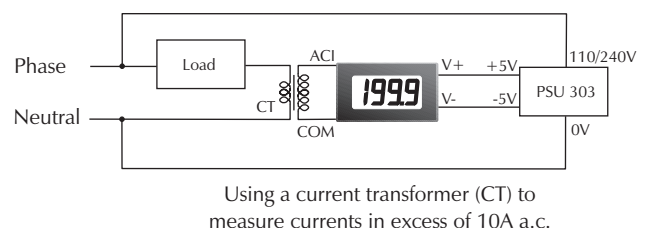

Using a current transformer (CT) to measure currents in excess of 10A a.c.