

# Crimp Attachment for Flexible Cable and Direct Solder for Semi-Rigid Cable

## Right Angle Solder Plug - Semi-Rigid Cable

P.N.	Cable Group	Plt.	Ins.	Imp.	Crimp Tool
SMB6182A1-NT30G-11-50	11	Nickel	Teflon	50	N/A
SMB6182A1-3GT30G-11-50	11	Gold	Teflon	50	N/A
SMB6182A1-3GT30G-13-50	13	Gold	Teflon	50	N/A



SMB6182A1-NT30G-11-50,  
SMB6182A1-3GT30G-11-50

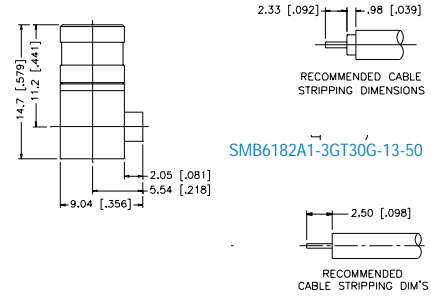

Note: Female center contact

Assembly Instruction F - page 214

## Bulkhead Feedthrough Crimp Jack - Flexible cable

P.N.	Cable Group	Plt.	Ins.	Imp.	Crimp Tool
SMB1421A1-002-NT30G-5-50	05	Nickel	Teflon	50	1 or 2
SMB1421A1-NT30G-3-50	03	Nickel	Teflon	50	1 or 2
SMB1421A1-3GT30G-5-50	05	Gold	Teflon	50	1 or 2
SMZ1421G6-3GT30G-6-75	06	Gold	Teflon	75	1 or 2
SMB1421A1-NT30G-5-50	05	Nickel	Teflon	50	1 or 2
SMB1421A1-3GT30G-5A-50	05A	Gold	Teflon	50	2
SMB1421A1-NT30G-14-50	14	Nickel	Teflon	50	1 or 2
SMB1421A1-3GT30G-14-50	14	Gold	Teflon	50	1 or 2
SMC Connectors					
SMC1421G1-NT30G-5-50	05	Nickel	Teflon	50	1 or 2
SMC1421A1-3GT30G-5-50	05	Gold	Teflon	50	1 or 2

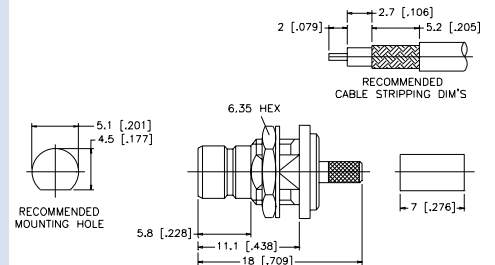

Note: Male center contact

Assembly Instruction J - page 218

## Right Angle Crimp and Solder Jack - Flexible & Semi-Rigid Cable

P.N.	Cable Group	Plt.	Ins.	Imp.	Crimp Tool
SMB1112A1-NT30G-5-50	05	Nickel	Teflon	50	1 or 2
SMB1112A1-3GT30G-5-50	05	Gold	Teflon	50	1 or 2
SMB1112A1-3GT30G-13-50	13	Gold	Teflon	50	N/A

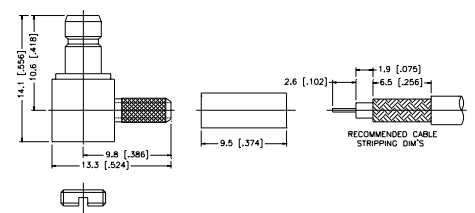

Note: Male center contact

Assembly Instruction F - page 214  
Assembly Instruction I - page 217

## Right Angle Bulkhead Crimp Jack - Flexible Cable

P.N.	Cable Group	Plt.	Ins.	Imp.	Crimp Tool
SMB1412A1-NT30G-1-50	01	Nickel	Teflon	50	3 or 4
SMB1412A1-3GT30G-1-50	01	Gold	Teflon	50	3 or 4
SMB1412A2-3GT30G-1A-50	01A	Gold	Teflon	50	3 or 4
SMB1412A1-001-NT30G-5-50	05	Nickel	Teflon	50	1 or 2
SMB1412A1-001-3GT30G-5-50	05	Gold	Teflon	50	1 or 2
SMB1412A1-NT30G-5A-50	05A	Nickel	Teflon	50	2
SMB1412A1-3GT30G-5A-50	05A	Gold	Teflon	50	2
SMB1412A1-3GT30G-14-50	14	Gold	Teflon	50	1 or 2



SMB1412A1-NT30G-1-50, SMB1412A1-3GT30G-1-50,  
SMB1412A2-NT30G-1A-50, SMB1412A2-NT30G-1A-50

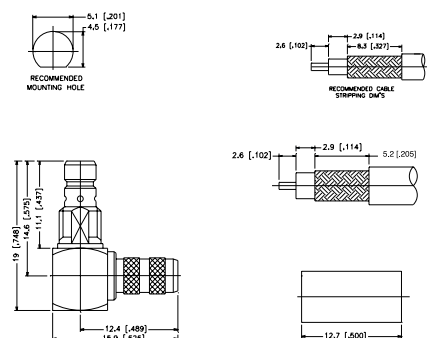

Note: Male center contact

Assembly Instruction I - page 217