

CONSTRUCTION

The basis of the construction is a formed base panel into which is attached the plastic moulded front panel with two securing brackets. The top cover is placed on top of the base panel and is fixed via two screws through the base and with screws through the flat rear panel. Two side chassis are attached to the base to permit the fixing of metric and eurocard based pcbs. Additional cross members can be added to facilitate non-board based components and other metalwork. An interior front panel is attached to the side chassis to form RFI/EMI shield for the component mounting area of the product. The shielding performance can be improved by the addition of copper beryllium fingers to ensure metal to metal contact between the base, front, top and rear panels. (supplied as accessories). Clip in guides can be fixed directly to the side chassis members to allow direct mounting of 160mm & 220mm double eurocard boards.

Additional to the standard rubber foot, is the tilt foot which can be added to give better angles of operation for the user. The sloping front panel gives an approximate 15 degree viewing angle.

APPLICATIONS

These attractive enclosures offer a unique opportunity to mount either metric or eurocard pcbs in a standard enclosure offering a good level of EMC protection.

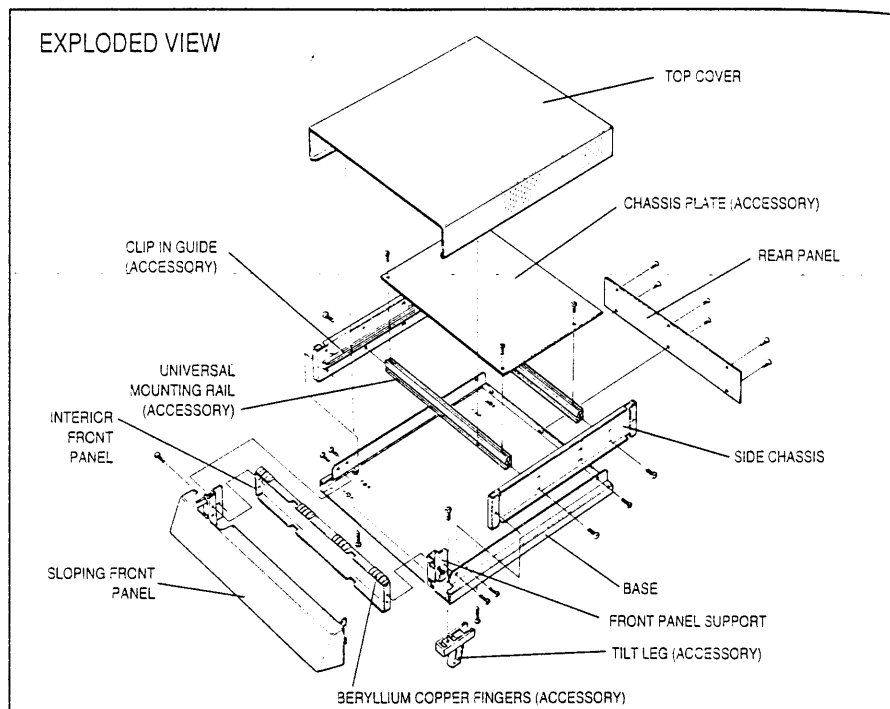

The plastic sloping front panel gives an aesthetic and user friendly interface, whilst the EMC protection is maintained by the interior front panel. The underside of the sloping front panel and the sides of the top cover have been ventilated to give the user the opportunity to have convectional or forced air cooling.

These products are ideally suited for telecomms, instrumentation and medical applications, offering technical competence and custom flexibility.

CONTENTS OF KIT

- 1 Top cover
- 1 Base
- 2 Chassis side members
- 1 Rear panel
- 4 Rubber feet
- 1 Plastic sloping front panel
- 2 Front panel supports
- 1 Interior front panel
- 1 Screw fixing kit

ACCESSORIES

- Copper beryllium fingers
- Chassis plate
- Tilt feet
- Universal mounting kit
- Clip in guides
- Tilt carry handle

DIMENSIONAL DETAILS

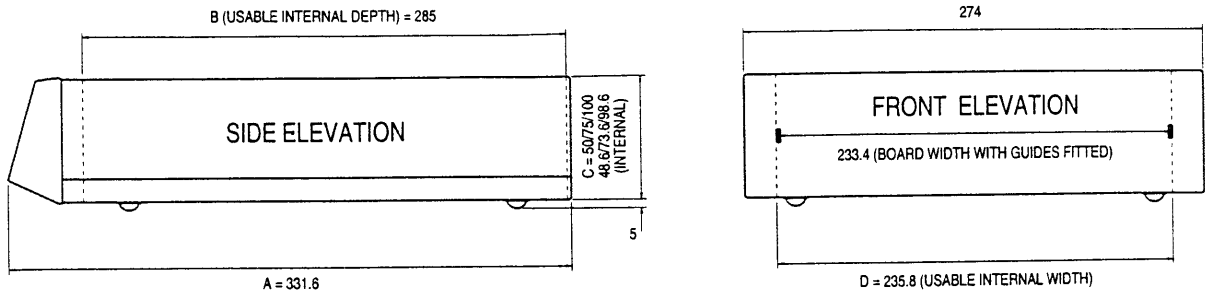

EBX CASES
SHIELDING EFFECTIVENESS (50MM X 300MM)

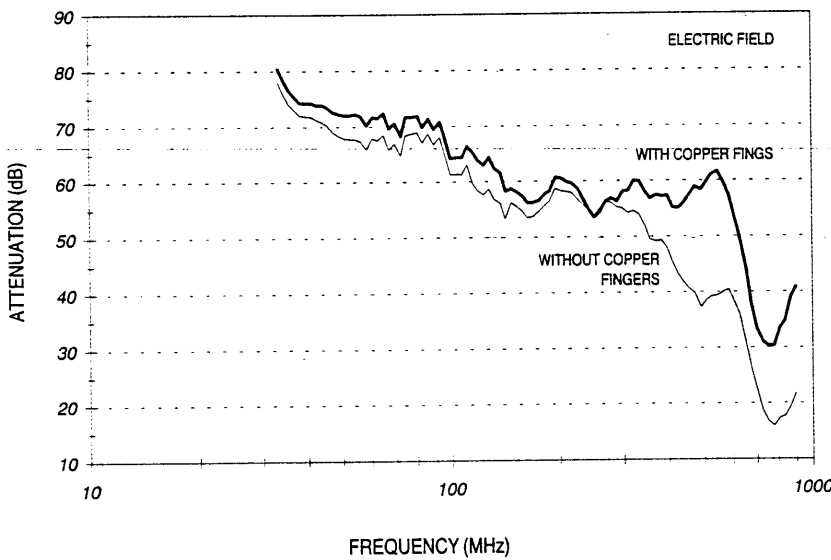

EMI/RFI PROTECTION

These products have been designed with EMI/RFI protection. All interior surfaces are paint free, thus giving the maximum opportunity for metal to metal contact. Additional beryllium copper fingers give an improved performance and can be added according to the application requirement. With copper fingers fitted to the interior front and rear panels, the attenuation levels are in excess of 55dB from 30-600MHz, declining progressively to 40dB at 1GHz. These tests were carried out in accordance with MIL STD 285-1, with no active components present in the enclosure. Please note: all modifications to these enclosures should be carried out in accordance with good EMC practice.

MATERIAL SPECIFICATION

- Rear panel : 0.9mm Zintec steel
- Top and bottom covers : 0.7mm Zintec coated steel
- Front panel : ABS Black
- Side chassis & interior front panel : 0.9mm Zintec steel
- Feet : Self adhesive rubber
- Front panel supports : 1.2mm Zintec steel
- Colours : ABS Black (Tilt)
- Colours : Black epoxy powder paint Black ABS.

VEROBXES[®] EBX CASES

Ordering information

Description	Height (mm)	Width (mm)	Depth (mm)	A	B	C	D	Order code
Size 1	50	275	200	231.6	185	48.6	235.8	53-251592J
Size 2	75	275	200	231.6	185	73.6	235.8	53-251593F
Size 3	50	275	300	331.6	285	48.6	235.8	53-251594C
Size 4	75	275	300	331.6	285	73.6	235.8	53-251595L
Size 4	100	275	300	331.6	285	98.6	235.8	53-251596H