

LOC	DIST	P	F	ZONE	LTR	DESCRIPTION	DATE	APPD
BD	48				A2	REV. & REDRAWN ECN-1119	7-18-85	SW
					B	REVISED PER ECN BD6802	12/03/92	RM
					B1	ADDED -4 PER NPR 4855	07/07/93	SB
					C	OBS -4 PER EC 0420-141-96	17 SEPT 97	SB

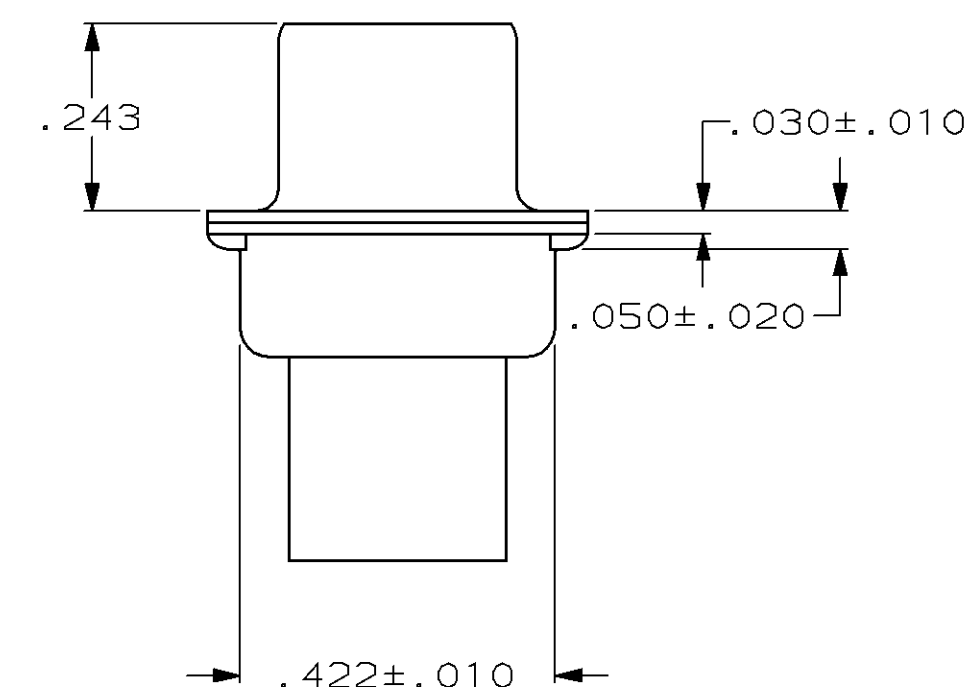
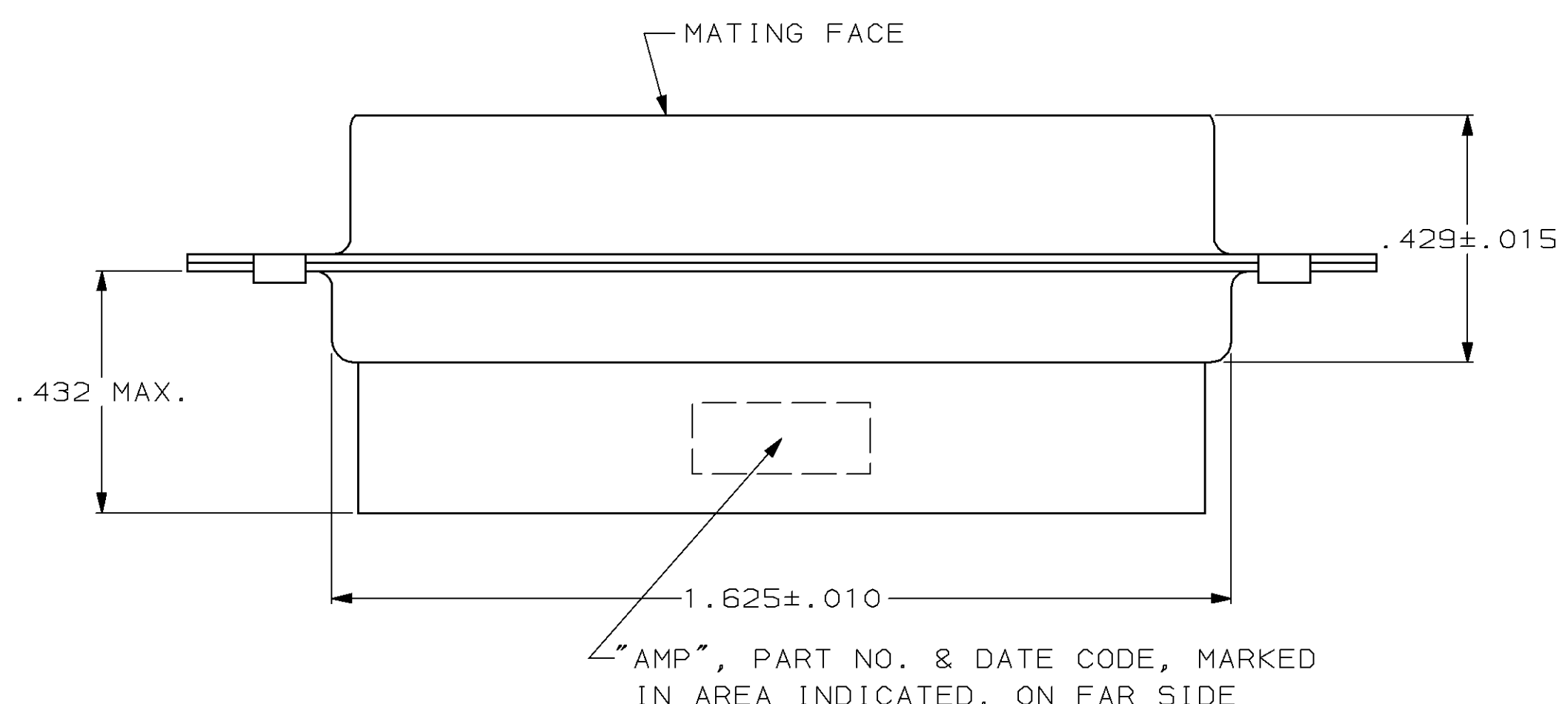
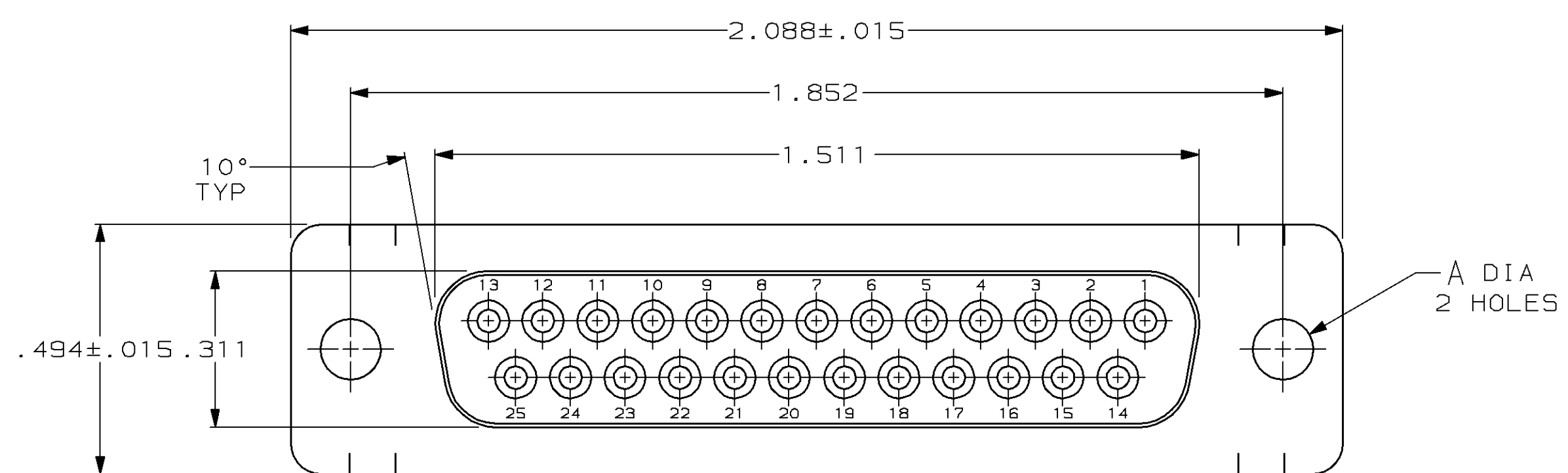

- CONNECTOR ACCEPTS SIZE 20 DF SOCKET CONTACTS, RETENTION TINES ARE AN INTEGRAL PART OF INSERT.
- CONNECTOR COMPLIES WITH 108-40005 WHERE APPLICABLE.
- NYLON, FLAME RETARDANT, 94V-0 RATED, GLASS FILLED, BLACK.
- STEEL PER ASTM A109.
- TIN OR TIN-LEAD PLATED PER MIL-T-10727.
- TIN PLATED PER MIL-T-10727 OVER COPPER PER MIL-C-14550.

OBSOLETE	SMALL PACK	△6	.120	207463-4
	STANDARD	△5	.154	207463-2
	STANDARD	△6	.120	207463-1
	PACKAGING TYPE	SHELL FINISH	A	PART NO

DO NOT SCALE PRINT. UNLESS SPECIFIED DIMENSIONS IN INCHES TOLERANCES ON : 2 PLC DEC ± - 3 PLC DEC ± .005 ANGLES ± 2°	DR 7-19-85 S.WELDON	AMP Incorporated Harrisburg, PA 17105-3608		
	CHK 7-29-85 J.GERACE			
MATERIAL	APPD 7-29-85 L.BREKOSKY	NAME		
MOLDED PARTS: △3 SHELLS: △4	APPD 7-31-85 V.KUMAR	RECEPTACLE CONNECTOR, SIZE 3, 25 POSITION, AMPLIMITE™ HDP		
FINISH	PRODUCT SPEC -	SIZE	CAGE CODE	DRAWING NO
SHELLS: SEE TABLE	APPLICATION SPEC -	C	00779	C=207463
	WEIGHT -	SCALE	4:1	SHEET 1 OF 1

THIS DRAWING IS A CONTROLLED DOCUMENT FOR AMP INCORPORATED. IT IS SUBJECT TO CHANGE AND THE CONTROLLING ENGINEERING ORGANIZATION SHOULD BE CONTACTED FOR THE LATEST REVISION.