

Special Load PCB Relay 409 47, 409 67

1 pole 10 A, for high inrush currents,
mono- or bistable



F0249-A

Features

- Specifically designed to handle high inrush currents
- Tungsten prerun contact
- 500 A / 10 μ s inrush peak current
- DC- or bistable version
- 4 kV / 8 mm coil-contact
- meets protection class II requirements

Applications

Dimmer switches, movement sensors, filament loads, halogen bulbs, motors and electrovalves



Technical data of approved types on request

Contact data

Configuration	1 N/O contact
Type of contact	single contact
Rated current	10 A
Rated voltage / max.breaking voltage AC	250 Vac / 400 Vac
Maximum breaking capacity AC	2500 VA
Make current (max. 4 s at duty cycle 10%)	16 A
peak inrush current 10 μ s / 20 ms	500 / 120 A
Contact material	W (prerun contact) + AgCdO

Contact ratings

Type	Load	Operations	Standard
409	10 A, 250 Vac, resistive	2.5x10 ⁵	
409	1300 W, fluorescent lamps, 140 μ F	3x10 ⁴	
409	2500 W, incandescent lamps	3x10 ⁴	
409	1000 W, Dulux lamps, 140 μ F	3x10 ⁴	

Coil data

monostable DC coil

Nominal voltage	5...110 Vdc
Nominal coil power	820 mW
Operate category	2 / b

Coil versions monostable

Coil code	Nominal voltage Vdc	Pull-in voltage Vdc	Release voltage Vdc	Maximum voltage Vdc	Coil resistance Ω	Coil current mA
031	12	7.5	0.9	14.2	170\pm10%	71.0
027	24	18.0	1.8	34.6	880\pm15%	27.0
024	48	34.5	3.6	60.6	2700 \pm 15%	18.0
023	60	41.0	4.5	77.8	4400 \pm 15%	14.0

All figures are given for coil without preenergization, at ambient temperature +20°C

Other coil voltages on request

Coil operating range DC

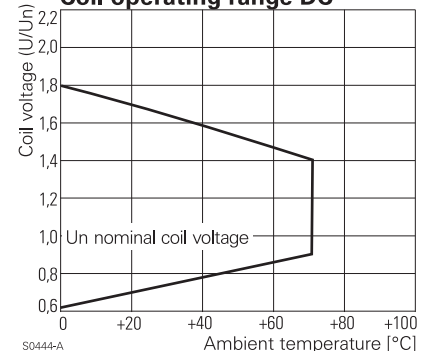

Special Load PCB Relay 409 47, 409 67

1 pole 10 A, for high inrush currents,
mono- or bistable

Coil data bistable	1 coil
Nominal voltage	6...100 Vdc
Nominal coil power	0.8...1 W
Minimum energization time	20 ms

Coil versions bistable, 1 coil

Coil code	Nominal voltage Vdc	Pull-in voltage Vdc	Reset voltage min Vdc	Reset voltage max Vdc	Coil resistance Ω	Coil current mA
032	12	8.9	0.7	2.5	118 \pm 10%	102.0
029	24	18.0	1.3	5.0	457 \pm 10%	53.0

All figures are given for coil without preenergization, at ambient temperature +20°C, duty cycle 20%

Other coil voltages on request

Insulation

Dielectric strength	coil-contacts	4000 V _{rms}
	open contact circuit	1000 V _{rms}
Clearance / creepage		8 / 8 mm
Insulation to VDE 0110b (2/79)		
	Insulation category / reference voltage	C / 250
Tracking resistance of relay base		PTI 250

Other data

Flammability class according to UL 94	V-0
Ambient temperature	-20...+70 °C
Mechanical life	30x10 ⁶ operations
Max. switching rate at rated- / minimum load	15 min ⁻¹ / 1200 min ⁻¹
Operate- / release time	typ. 10 / 3 ms
Bounce time	typ. 3 ms
Vibration resistance	20 g (30...300 Hz)
Shock resistance (destruction)	100 g
Category of protection (IEC 61810)	RT II - flux proof
Relay weight	16 g
Packaging unit	25 / 250 pcs.

PCB layout / terminal assignment

View on solder pins
Dimensions in mm

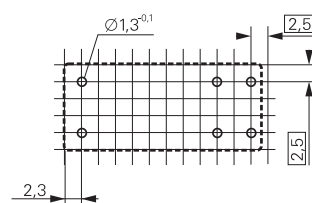

S0163-CX

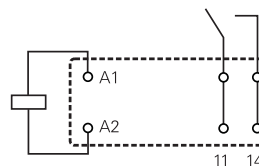

S0163-BF

Bistable versions:
Indicated contact position during or after coil energization with reset voltage.

Special Load PCB Relay 409 47, 409 67

1 pole 10 A, for high inrush currents,
mono- or bistable

Dimensions

Dimensions in mm

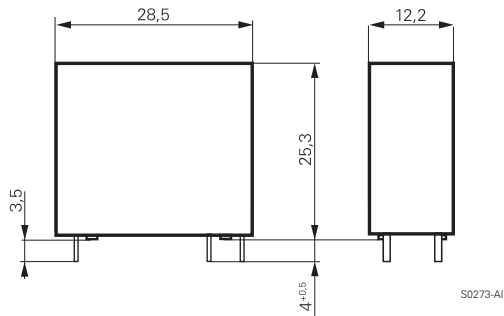

Product key

0 4 0 9 **7** **0 0 1**

Type

Coil version

- 47** Monostable version
- 67** Bistable version

Coil

Coil code: Please refer to coil versions table, preferred types in bold print

Contact configuration

- 001** 1 N/O contact

Other types on request

Product key	Version	Contacts	Coil	Coil	Part number
0409 47 031 001	10A	1 N/O	DC-coil	12Vdc	1-1415403-6
0409 47 028 001	flux proof	W prerun		24Vdc	1-1415403-4
0409 67 032 001		AgCdO	bistable	12Vdc	0-1415405-0
0409 67 029 001			1 coil	24Vdc	0-1415405-1