

149-461 → 493

TABLE 5. SLOTTED CHEESE HEAD MACHINE SCREWS. METRIC SERIES

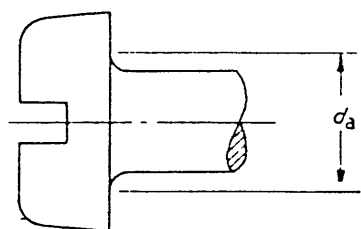
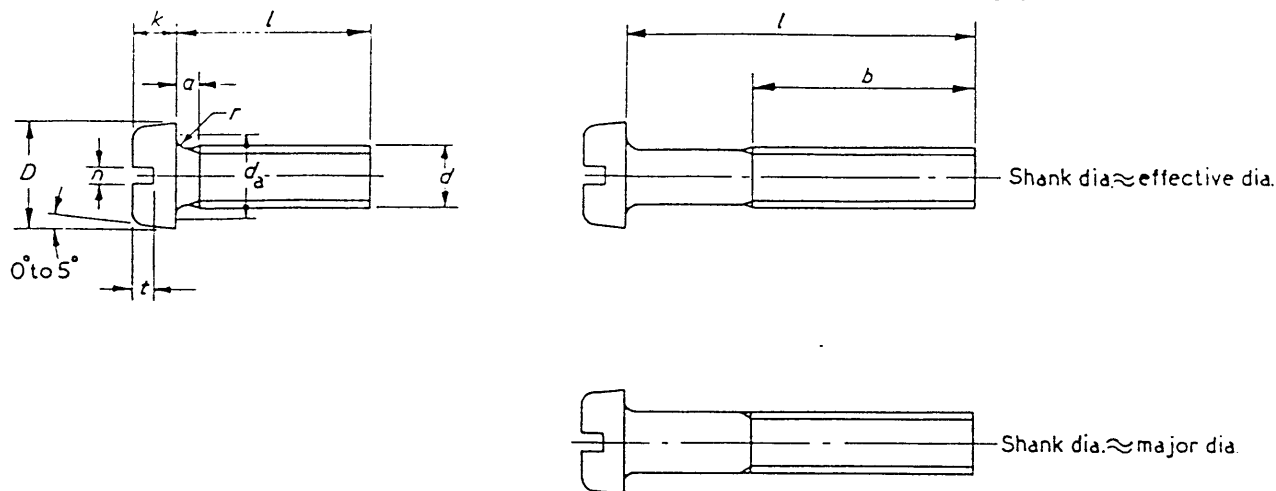

Enlarged view of transition diameter (d_a)

26

Dimensions in millimetres

Dimensions in millimetres												
1	2	3	4	5	6	7	8	9	10	11	12	13
General							Slotted heads					
d	D		k		r	d_a	b	a	n		t	
Nominal size and thread diameter	Head diameter		Head height		Radius	Transition diameter	Thread length	Thread run-out	Width of slot		Depth of slot	
	Max.	Min.	Max.	Min.	Min.	Max.	Min.	Max. †	Max.	Min.	Max.	Min.
M1	2.00	1.75	0.70	0.56	0.10	1.30	*	0.50	0.45	0.31	0.44	0.30
M1.2	2.30	2.05	0.80	0.66	0.10	1.50	*	0.50	0.50	0.36	0.49	0.35
(M1.4)	2.60	2.35	0.90	0.76	0.10	1.70	*	0.60	0.50	0.36	0.60	0.40
M1.6	3.00	2.75	1.00	0.86	0.10	2.00	15.00	0.70	0.60	0.46	0.65	0.45
M2	3.80	3.50	1.30	1.16	0.10	2.60	16.00	0.80	0.70	0.56	0.85	0.60
(M2.2)	4.00	3.70	1.50	1.36	0.10	2.80	17.00	0.90	0.80	0.66	1.00	0.70
M2.5	4.50	4.20	1.60	1.46	0.10	3.10	18.00	0.90	0.80	0.66	1.00	0.70
M3	5.50	5.20	2.00	1.86	0.10	3.60	19.00	1.00	1.00	0.86	1.30	0.90
(M3.5)	6.00	5.70	2.40	2.26	0.10	4.10	20.00	1.20	1.00	0.86	1.40	1.00
M4	7.00	6.64	2.60	2.46	0.20	4.70	22.00	1.40	1.20	1.06	1.60	1.20
(M4.5)	8.00	7.64	3.10	2.92	0.20	5.20	24.00	1.50	1.20	1.06	1.80	1.40
M5	8.50	8.14	3.30	3.12	0.20	5.70	25.00	1.60	1.51	1.26	2.00	1.50
M6	10.00	9.64	3.90	3.72	0.25	6.80	28.00	2.00	1.91	1.66	2.30	1.80
M8	13.00	12.57	5.00	4.82	0.40	9.20	34.00	2.50	2.31	2.06	2.80	2.30
M10	16.00	15.57	6.00	5.82	0.40	11.20	40.00	3.00	2.81	2.56	3.20	2.70
M12	18.00	17.57	7.00	6.78	0.60	14.20	46.00	3.50	3.31	3.06	3.80	3.20
(M14)	21.00	20.48	8.00	7.78	0.60	16.20	52.00	4.00	3.31	3.06	4.20	3.60
M16	24.00	23.48	9.00	8.78	0.60	18.20	58.00	4.00	4.37	4.07	4.60	4.00
(M18)	27.00	26.48	10.00	9.78	0.60	20.20	64.00	5.00	4.37	4.07	5.10	4.50
M20	30.00	29.48	11.00	10.73	0.80	22.40	70.00	5.00	5.27	5.07	5.60	5.00

NOTE. Nominal thread diameters shown in brackets are non-preferred.

* Threaded up to head only.

† See 9.3.

27