

R8C Family

Consumer and Industry Applications



Introduction

Renesas Technology is one of the largest semiconductor companies in the world

- Established on 1st April, 2003 as a joint venture between Hitachi Ltd and Mitsubishi Electric Corp.
- Headquartered in Tokyo, Japan with over 26,000 employees worldwide
- Designs and manufactures highly integrated semiconductor solutions for industrial, consumer, automotive and telecoms markets
- Ranked the No. 1 microcontroller supplier globally and the No. 1 global supplier of embedded flash MCU's

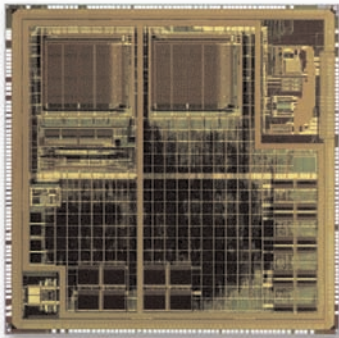

Renesas Technology owes its success to its outstanding technology, its excellent quality and to its drive and commitment to listen and meet our customers' needs.

As a result, today Renesas Technology is the world's leading microcontroller company offering a huge range of 8-, 16- and 32-bit microcontrollers. These feature:

- A complete product line-up
- Outstanding memory integration
- World leading embedded Flash technology
- Leading peripheral integration
- High performance CPU's
- Low power consumption
- Low EMS / EMI
- Advanced packaging options



The Renesas M16 & R8 microcontroller families

Today, Renesas offers the H8 and M16C CISC microcontroller families and the high-performance SH RISC microcontroller family.

H8 Microcontroller families

The H8 family comprises of a wide range of CISC microcontrollers from low-cost 8-bit to the most sophisticated, high-performance 32-bit.

- The H8/300L Super Low Power series of 8-bit microcontrollers has been developed to meet the demands of the next generation of power critical applications.
- The H8/300H Tiny provides design engineers with a low-cost 16-bit alternative to many 8-bit microcontrollers available today.
- The H8/300H provides a highly competitive 16-bit Flash microcontroller family for consumer and industrial applications.
- The H8S leading edge 16-bit family combines high memory and peripheral integration with high performance.
- The H8SX family now provides an H8 code-compatible roadmap to 32-bit performance.

M16C and R8C Microcontroller families

The M16C platform consists of a wide range of 16-bit microcontrollers featuring high efficiency 'C' programming, high-speed processing and low power consumption.

- The R8C Tiny comes as an ultra low-cost, Flash family in small pin-count packages addressing the classic 8-bit market.
- The M16C/2x and M16C/6x high-performance families provide high peripheral integration, low power consumption and low EMS/EMI.
- The M32C family, with its rich set of peripherals, builds the performance bridge between the 16-bit CISC and 32-bit RISC world.

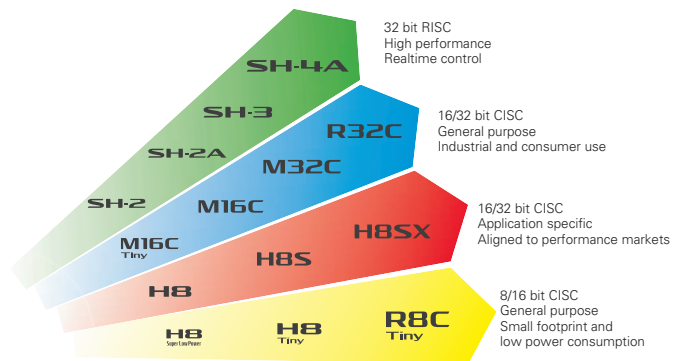

The SH Microcontroller Families

The SH microcontroller families offer the highest performance levels found on microcontrollers today. In particular SH-2A offers up to 480 DMIPS today and also interrupt response times of just 30ns. Renesas developed the world's fastest Flash technology - called MONOS Flash - to support such high speed with no wait states. The family ranges from:

- The low cost SH-Tiny series with 64KB and 128KB Flash options and in 48-/64-pin packages. Aimed at white goods motor control.
- The mid-class SH2-based SH708xF and SH714xF series with up to 80MHz (zero wait) 512KB MONOS Flash and 176 pins, triple fast ADC as well as strong timer resources to drive up to two motors. Available in 3V and 5V.
- The highend SH-2A products with 512KB MONOS Flash in the SH7211F as well as a line-up of highly integrated rom-less versions with 4 x SCI, 3 x IIC, 2 x CAN, USB host and function and TFT drive on the SH7203, for example. At 200MHz and with additional FPU this device competes with industrial PC, yet is a fraction of the cost and power consumption, available long term and in Renesas' best-in-class quality.

R8C Introduction

More performance on 8bit application

The R8C microcontroller family is the latest in a line of high performance microcontrollers from Renesas. At the beginning of April 2003 we offered the 1st R8C devices, with the unique innovation of the combination of an 16-bit core and 8-bit internal bus, to maximise performance and minimise cost. First we introduced the R8C/1x devices in 20pin & 32pin packages with memory sizes from 4K to 16kbyte flash. With the 2nd R8C/2x generation by end of 2005 we added the high-speed 40MHz on-chip oscillator, new powerful features like Motor Control timers, CAN, DA converter, RTC, decrease the Vcc power supply to 2.2V and a lot of other useful features like low power modes down to 0.7µA in STOP mode 1.8µA in WAIT mode.

Thanks to the popular M16C core, the R8C has the same well known reliability and also an excellent

reputation in the MCU market. With its short instruction cycles at 50ns (20MHz) and the excellent code density it is possible to use smaller flash sizes, which also helps to save cost. This combination of embedded features, reducing code, high reliability offers developers a microcontroller for more performance on 8-bit applications!

With its on-chip flash memory from 4kbyte to 128kbyte and a wide range of peripherals in packages of 20, 32, 48, 52, 64pin and 80 pins the series has grown dramatically, more than 260 devices are in volume production today.

By Q3/2008, we will introduce the next generation of R8C/3xA. These will support the voltage ranges down to 1.8V and will get additional advanced high-performance features. As a general purpose device the R8C is suitable for different applications in different packages.

R8C Roadmap - Generation

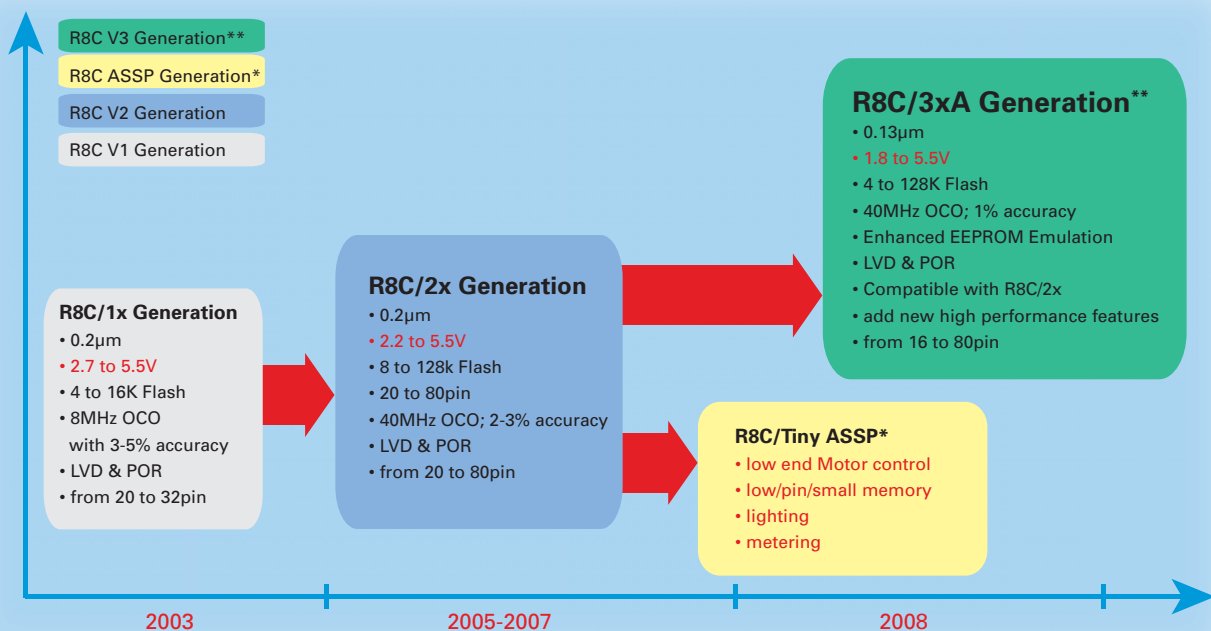

* ASSP: Application Specific Standard Products
** new Family Q3/2008 first devices 20; 32; 52pin up to 32kbyte

High Performance 16bit

R8C/Tiny series meets your needs and system for a 16-bit MCU with a compact board-mounting space and a low-pin count.

The new R8C/Tiny series of MCU's is a high performance lineup of 16-bit MCU's that boost low voltage and power consumption while offering high

speed operational processing. Applicable from consumer products to industry and automobiles by a wide range of product availability, the R8C/Tiny series brings together the easy-to-use properties of the H8/300H Tiny and the excellent ROM and C language efficiency seen in the M16C.

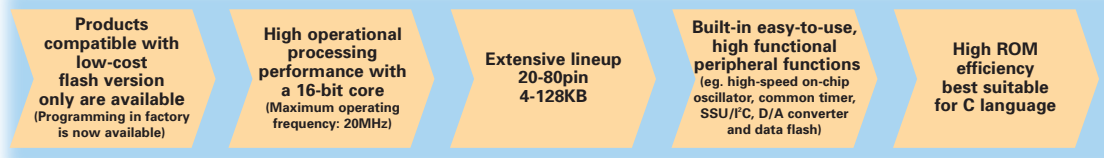

R8C/Tiny Roadmap

| Pin count | Strengthened SSUFC function (combined with H8/Tiny) | Improved flash characteristic (0.2HNDs) | Strengthened timer function (combined with H8/Tiny and 740) | Lineup expansion Built-in D/A | Application specific expansion Slimmed-down functionality |
|-----------|--|--|---|--|---|
| 80 | | | | R8C/2C-2D* Supports low voltage operating Built-in D/Aa | |
| 64 | | | Strengthened functions | R8C/2A-2B* Supports low voltage operating Built-in D/Aa | |
| 52 | | | R8C/24-25* Supports low voltage operation | | |
| 48 | | | R8C/22-23* Built-in CAN for automotive R8C/20-21* For automotive | | |
| 32 | R8C/10-12* Speeding up Strengthened communication function | R8C/11-13* Strengthened communication function | R8C/26-27* For general and automotive Supports low voltage operation | R8C/2K,2L* Motor control R8C/2E,2F* Lighting control R8C/2G A/D converter deletion | |
| 20 | R8C/14-15* A/D deletion | R8C/16-17* Improved characteristics R8C/18-19* A/D deletion | R8C/28-29* For general and automotive Supports low voltage operation | R8C/2H A/D converter deletion R8C/2J* General-purpose 1K,2K flash; 16 Pin | |

*: Equipped with data flash : Under mass production : Under development *: Under development. Availability planned for Q3/2008 *: Under development. Availability planned for Q1/2009

High Performance 16bit

The R8C are general purpose devices with high-performance features and the ideal solution for tomorrow's consumer and industry applications. A lot of devices are also available with automotive specification and CAN interface. The high-performance 16-bit Timers (with 40MHz clock source)

can drive up to 13 x PWM and also includes support for 3-phase motor control with automatic dead time insertion. Therefore it is easy to realize motor control applications. The internal 40MHz high-speed oscillator has an accuracy down to +/-2% over the total temperature range and can be calibrated down to 1%. To make your system more reliable, these devices include different fail-safe functions like clock-stop detection, SFR protection, dataflash, watchdog time, etc.. This helps to reduce costs in the next generation of small application, white goods, industrial and security applications. Other applications include low-power/battery applications and induction heating applications.

Low power consumption operation

Low-cost development environment
(an on-chip debugger, a starter kit, and a CPU board included)

Extensive information service
(At Renesas' website, and through application notes and instruction manuals etc.)

Operating at 1.8 to 5.5V
1% OCO; On-chip DTC, SA' flash memory

R8C/3xA**

R8C/3xA**

R8C/35A**

up to 32kbyte

R8C/36A**

up to 128kbyte

R8C/33A**

up to 32kbyte

R8C/32A**

up to 16byte

R8C/3xA**

16 Pin

Application Example

General Purpose



Automotive



Building Automation



EPOS/Vending



Health/Fitness



Metering



Motor Control



Small Appliances



White Goods



Target Market

Suitable Market

R8C – The latest innovation of Microcontroller

- For more performance on today's and tomorrow's 8bit applications
- Low pin - small memory – low price
- Quick time to market
- FLASH only microcontroller

CPU Core/Register Model

- 16-bit CPU core
- 8-bit CPU internal data bus

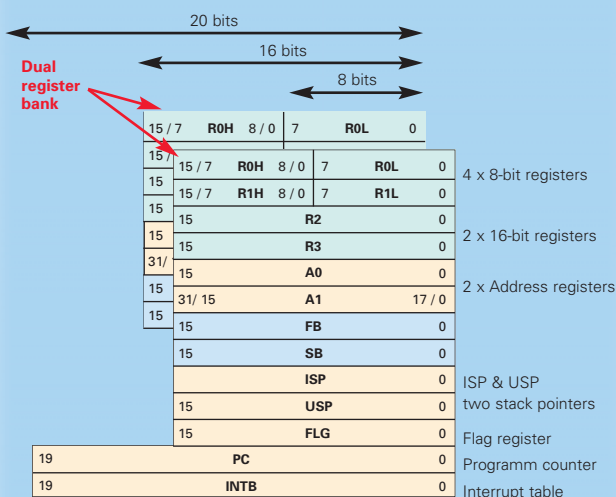

- Multiplier: $16 \times 16 \rightarrow 32$
- Multiplier-accumulate instruction: $16 \times 16 + 32 \rightarrow 32$

Basic peripherals for R8C/1x Family

20MHz (50ns – shortest instruction)
 Three clock circuits
 - two internal ring oscillator
 - 8MHz (+/-3%)
 - 125KHz
 Clock-stop detection
 4 x 10bit ADC
 1 x USART
 1 x UART
 1 x I2C or SPI (SSUA)
 4/8 x LED ports (20mA driver)
 2 x 8-bit Timer (with prescaler)
 1 x 16-bit Timer – capture compare
 POR, LVD (two levels)
 Flash: 4 to 16KB
 RAM: 376B to 1KB
 Dataflash: 2 x 1K or 2K
 Vcc: 2.7 to 5.5V

- **R8C/2x Family with additional features:**
 - dedicated Timers for
 - 3 phase Motor control
 - D/A converter
 - CAN interface
 - 40MHz OCO with 1% accuracy
 - 32KHz + RTC
 - 2.2V
 - low power

Flash: 8KB - 128KB
 RAM: 512B - 7.5kB
 Dataflash: 2 x 1K
 Vcc: 2.2V – 5.5V

- R8C CPU performance – more performance on 8-bit application
 - 50ns (at e.g. 20MHz) for shortest instruction
- Code density (generates 10 to 50% less code)
 - 2 x MCU register banks available (avoid push & pop), excellent code instructions
- Excellent reputation of Renesas Flash Technology
 - robustness and reliability
 - EMI, EMS countermeasures
- High performance 0.2µm single-voltage flash
- Data-Flash to substitute external EEPROM
- Cost saving peripheral integration
 - POR, LVD, WDT, Dataflash, 2 x internal oscillators
- Low-cost development tool chain
 - On-Chip Debugger via one wire
 - Flash interface via one wire

Basic peripherals for R8C/2x Family

- 20MHz (50ns – shortest instruction)
- Four clock circuits
- Two Internal on-chip oscillators
 - 40MHz OCO (1% calibrated)
 - 125KHz OCO
- Clock-stop detection
- HW Multiplier
- 32KHz – with one week RTC
- Watchdog with independent oscillator
- Up to 20 x 10-bit ADC
- D/A converter
- 1-3 x USART
- 1 x I2C or SPI (SSUA)
- 1 x LIN HW- module
- 1 x CAN interface
- 4/8 x LED ports (20mA drive)
- 2 x 8-bit Timer
- 1 x 8-bit Timer + with one week RTC
- 2-3 x 16-bit Timer – I/C & OC
- POR, LVD (three levels)
- Low power modes
 - (Stop mode: 0.7µA; Wait mode: 1.8µA)
- Single wire On-chip debug interface

Platform compatibility

R8C and M16C have the same 16bit core

Quick time to market, reducing the total system & development cost is mandatory these days. Therefore, it is important to have a microcontroller family which can offer embedded high performance, software compatibility, a wide range of products and reliability. Renesas, as a No.1 company in microcontroller, is offering this on the R8C/M16C platforms:

- MCU Platform – code compatible to the well known M16C/M32 family
- More performance in 8-bit applications
- Best EMI performance
- Provide best C code efficiency
- Reduce system cost not only MCU cost
- powerful 8-bit/16-bit timers and features
 - high performance 16-bit Timer RC and Timer RD with 40MHz clock source
 - special timer for 3 phase motor control application (PWM with 40MHz OCO)
 - DA; comparators and up to 20 x 10 ADC with conversion at 3.3μs
 - excellent interrupt handling with selectable different priority level
 - high current drive port (up to +/-20mA)
- security and fail-save functionality & features
 - e.g. independent clock for WDT
 - clock-stop detection
 - code protection and SFR protection
 - cut-off ports (e.g. to avoid overcurrent)

High Performance Features

- Internal HW Multiplier
 - Multiplier: 16 x 16 → 32
 - Multiply - accumulate instruction: 16 x 16 + 32 → 32
- 40MHz internal oscillator
 - adjustable to 1% via software
 - best tolerance on total temperature range -40 to 85°C
- high-performance 16-bit Timer RD
 - to drive 3 phase motor control
- high-performance 16-bit Timer RC
 - with a lot of powerful timer modes
 - cut-off functions (e.g. over current)

- 32KHz – suitable for low power/battery application
 - with lower power consumption
 - WAIT mode down to 1.8μA; STOP mode 0.7μA
 - one week real time clock (RTC)
- multiple serial interfaces
 - SPI – I2C – UART – LIN - CAN
- Internal hardware multiplier

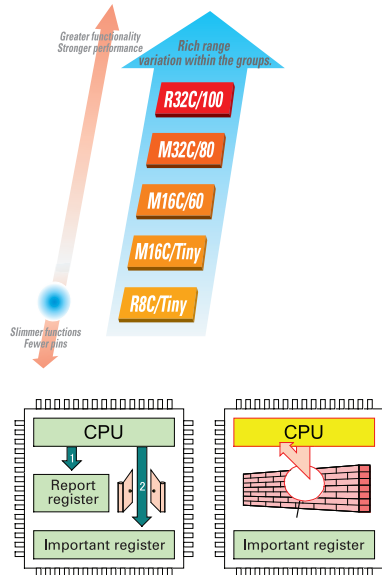

Example: 40MHz- On chip oscillator accuracy

Frequency vs Topr

(High-speed on-chip oscillator mode)

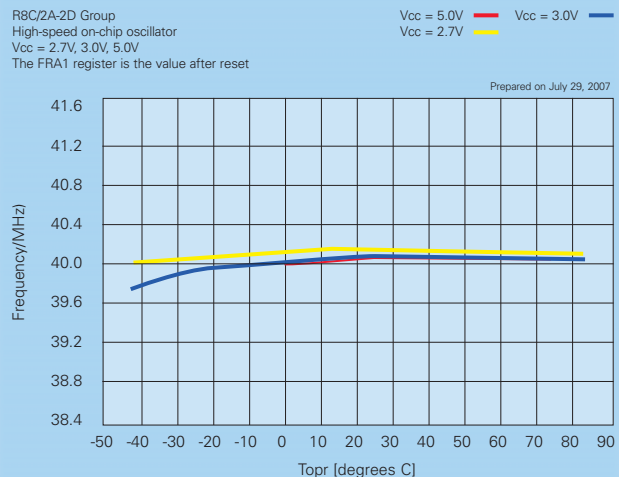

The mentioned value is only for your reference. The value is for the arbitrary samples and does not guarantee the product's characteristics.

R8C/2x Family

General Purpose Devices

| Item | R8C/28-29 | R8C/26-27 | R8C/22-23 | R8C/24-25 | R8C/2A-2B | R8C/2C-2D |
|---|---|--|--|---|---|---|
| Core | R8C core - 16-bit CPU | | | | | |
| Flash (byte) | 16K; 8K | 32K; 24K; 16K; 8K | 128K; 96K; 64K; 48K; 32K; 16K | 64K; 48K; 32K; 16K | 128K; 96K; 64K; 48K | 128K; 96K; 64K; 48K |
| RAM (byte) | 1K; 512 | 1.5K; 1.5K; 1K; 512 | 6K; 5K; 3K; 2.5K; 2K; 1K | 3K; 2.5K; 2K; 1K | 7.5K; 7K; 3K; 2.5K | 7.5K; 7K; 3K; 2.5K |
| Data Flash (byte) | 2 x 1K (only on R8C/29) | 2 x 1K (only R8C/27) | 2 x 1K (only on R8C/23) | 2 x 1K (only on R8C/25) | 2 x 1K (only on R8C/2B) | 2 x 1K (only on R8C/2D) |
| Clock circuits | 4 clock circuits with oscillation stop detection - external main clock (Xin, Xout) - 32kHz subclock (Xcin, Xcout) - internal low speed ring (125KHz) - internal high speed ring (40MHz) | | 3 clock circuits with oscillation stop detection - external main clock (Xin, Xout) - internal low speed ring (125KHz) - internal high speed ring (40MHz) | | 4 clock circuits with oscillation stop detection - external main clock (Xin, Xout) - 32kHz subclock (Xcin, Xcout) - internal low speed ring (125KHz) - internal high speed ring (40MHz) | |
| f(xin) max. | 20MHz@ 3.0 to 5.5V (50ns min. instruction) 10MHz@ 2.7 to 5.5V 5MHz@ 2.2 to 5.5V 32KHz - RTC 125KHz for low speed ring 40MHz for high speed ring (adjustable) | | 20MHz@ 3.0 to 5.5V (50ns min. instruction) 10MHz@ 2.7 to 5.5V 125KHz for low speed ring 40MHz for high speed ring (adjustable) | | 20MHz@ 3.0 to 5.5V (50ns min. instruction) 10MHz@ 2.7 to 5.5V 5MHz@ 2.2 to 5.5V 32KHz - RTC 125KHz for low speed ring 40MHz for high speed ring (adjustable) | |
| High speed on chip oscillator accuracy | 40MHz on chip oscillator +/-1% => 25°C @5V +/-2% => 0°C - 60°C @5V +/-3% => -20°C to 85°C @ -3.0V to 5.5V | | 40MHz on chip oscillator +/-1% => 25°C @5V +/-2% => 0°C - 60°C @5V +/-3% => -20°C to 85°C @ -3.0V to 5.5V +/-5% => -40°C to 125°C @ -3.0V to 5.5V | | 40MHz on chip oscillator +/-1% => 25°C @5V +/-2% => 0°C - 60°C @5V +/-3% => -20°C to 85°C @ -3.0V to 5.5V +/-2% => -20°C to 85°C @ -2.7V to 5.5V | |
| Pins | 20 | 32 | 48 | 52 | 64 | 80 |
| I/O ports | I/O 13 + 3 input | I/O 25 + 3 input | I/O 41 + 3 input | I/O 41 + 3 input | I/O 55 + 2input | I/O 71 + 2 input |
| LED direct drive | 8 x 20mA | | - | 8 x 20mA | | |
| Internal pull up | all I/O all selectable with pull up resistors | | | | | |
| Interrupts | 15 x intern 4 x extern selectable 7 priority level | 15 x intern 4 x extern selectable 7 priority level | 14 x intern 6 x extern selectable 7 priority level | 11 x intern 5 x extern selectable 7 priority level | 23 x intern 5 x extern selectable 7 priority level | 23 x intern 5 x extern selectable 7 priority level |
| Timers | 2 x 8bit (RA& RB - with prescaler) 1 x 8bit (RE - with prescaler one week RTC) 1 x 16bit (RC with IC & OC) | | 2 x 8bit (RA & RB - with prescaler) 1 x 8bit (RE - with prescaler OC) 2 x 16bit (RD with IC & OC) | | 2 x 8bit (RA & RB - with prescaler) 1 x 8bit (RE - with prescaler one week RTC) 1 x 16bit (RC with IC & OC) 2 x 16bit (RD with IC & OC) 1 x 16bit (RF with IC & OC) | |
| Watchdog | 1x 15bit (with independent 125KHz OCO) reset start selection | | | | | |
| Analog channels | ADC: 4 x 10bit - 3.3µs | ADC: 12 x 10bit - 3.3µs | | | | ADC: 20 x 10bit - 3.3µs (with additional scan mode) DA: 2 x 8bit |
| Serial I/O | 1 x USART (UART0) 1 x UART (UART1) 1 x SSUA or I2C 1 x LIN (via UART0 + Timer RA) | 2 x USART (UART0, UART1) 1 x SSUA or I2C 1 x LIN (via UART0 + Timer RA) | 2 x USART (UART0, UART1) 1 x SSUA or I2C 1 x LIN (via UART0 + Timer RA) 1 x CAN 2.0B | 2 x USART (UART0, UART1) 1 x SSUA or I2C 1 x LIN (via UART0 + Timer RA) | 3 x USART (UART0, UART1, UART2) 1 x SSUA or I2C 1 x LIN (via UART0 + Timer RA) | |
| Others | POR/LVD with three levels clock stop detection | | | | | |
| Run- mode | typ. 10 mA @ 5.0V, 20MHZ typ. 6 mA @ 3.0V, 10MHZ | typ. 10 mA @ 5.0V, 20MHZ typ. 6 mA @ 3.0V, 10MHZ | typ. 10 mA @ 5.0V, 20MHZ typ. 6 mA @ 3.0V, 10MHZ | typ. 10 mA @ 5.0V, 20MHZ typ. 6 mA @ 3.0V, 10MHZ | typ. 12 mA @ 5.0V, 20MHZ typ. 5.5 mA @ 3.0V, 10MHZ | typ. 12 mA @ 5.0V, 20MHZ typ.5.5 mA @ 3.0V, 10MHZ |
| Wait mode | a) with int. low speed ring: 25µA @5V (Peripheral clock stops) b) with 32KHz: 2.0µA | a) with int. low speed ring: 25µA @5V (Peripheral clock stops) b) with 32KHz: 2.0µA | a) with int low speed ring: 25µA @5V (Peripheral clock stops) b) with 32KHz: 2.0µA | a) with int low speed ring: 25µA @5V (Peripheral clock stops) b) with 32KHz: 2.0µA | a) with int low speed ring: 35µA @5V (Peripheral clock stops) b) with 32KHz: 2.1µA | a) with int low speed ring: 35µA @5V (Peripheral clock stops) b) with 32KHz: 2.1µA |
| Stop mode | Typ.0.7 µA @ 3.0V | Typ.0.7 µA @ 3.0V | Typ.0.7 µA @ 3.0V | Typ.0.7 µA @ 3.0V | typ.0.65 µA @ 3.0V | typ.0.65 µA @ 3.0V |
| Supply voltage | 2.2V to 5.5V | | 2.7V to 5.5V | | 2.2V to 5.5V | |
| Operating temperature | -20°C to +85°C (N version) std. spec. -40°C to +85°C (D version) industry spec. -20°C to +105°C (Y version) ext. temp. spec. (-40°C to +85°C (J version) automotive spec.) (-40°C to +125°C (K version) automotive spec.) | | -40°C to +85°C (D version) industry spec. (-40°C to +85°C (J version) automotive spec.) (-40°C to +125°C (K version) automotive spec.) | | -20°C to +85°C (N version) std. spec. -40°C to +85°C (D version) industry spec. -20°C to +105°C (Y version) ext. temp. spec. (-40°C to +85°C (J version) automotive spec.) (-40°C to +125°C (K version) automotive spec.) | |
| Package | 20pin SSOP - 0.65mm pin pitch | 32pin LQFP - 0.8mm pin pitch | 48pin LQFP - 0.5mm pin pitch | 52pin LQFP - 0.65mm pin pitch 64pin LGA - 0.65mm pin pitch | 64pin LQFP - 0.65mm pin pitch 64pin LQFP - 0.8mm pin pitch | 80pin LQFP - 0.5mm pin pitch |

R8C/1x Family

The first

| Item | R8C/18-19 | R8C/1A-1B | R8C/11 & 13 |
|--|---|---|---|
| Features | R8C core - 16-bit CPU | R8C core - 16-bit CPU | R8C core - 16-bit CPU |
| Flash (byte) | 16K; 12K; 8K4K | 16K; 12K; 8K4K | 16K; 12K; 8K |
| RAM (byte) | 1K; 768; 512; 384 | 1K; 768; 512; 384 | 1K; 768; 512 |
| Data Flash | 2 x 1K (only on R8C/19) | 2 x 1K (only on R8C/1B) | 2 x 2K (only on R8C/13) |
| Clock circuits | | 3 clock circuits with oscillation stop detection - external main clock (Xin, Xout) - internal low speed ring (125KHz) - internal high speed ring (8MHz) | |
| f(xin) max. | | 20MHz@ 3.0 to 5.5V (50ns min. instruction) 10MHz@ 2.7 to 5.5V 125KHz for low speed ring 8MHz for high speed (ring adjustable) | |
| High speed on chip oscillator accuracy | 8MHz internal OCO +/-3% => 0°C - 60°C @5V +/-4% => -20°C to 85°C @ 2.7V to 5.5V | | 8MHz internal OCO +/-5% => -10°C - 50°C @5V +/-10% => -40°C to 85°C @ 2.7V to 5.5V |
| Pins | 20 | | 32 |
| I/O ports | I/O 13 + 3 input | | I/O 22 + 2 inputs |
| LED direct drive | 4 x 20mA | | 8 x 20mA |
| Internal pull up | all I/O all selectable with pull up resistors | | |
| Interrupts | 10 x intern 4 x extern selectable 7 priority level | 9 x intern 4 x extern selectable 7 priority level | 11 x intern 5 x extern selectable 7 priority level |
| Timers | 2 x 8bit (Timer X, Z - with prescaler) 1 x 16bit (Timer C - with I/C & O/C) | | 3 x 8bit (Timer X, Y, Z) 1 x 16bit (Timer C - with I/C & O/C) |
| Watchdog | 1x 15bit (with independent 125KHz OCO) reset start selection | | 1x 15bit |
| Analog channels | Analog: 4 x compare 1 x USART (UART0) 1 x UART (UART1) | ADC: 4 x 10bit 1 x USART (UART0) 1 x UART (UART1) 1 x SSUA or I2C (selectable) | ADC: 12 x 10bit 1 x USART (UART0) 1 x UART (UART1) |
| Serial I/O | | | |
| Others | | POR/LVD with two levels clock stop detection | |
| Run- mode | typ. 9 mA @ 5.0V, 20MHZ typ.5 mA @ 3.0V, 10MHZ Typ.35 µA @ 3.0V (Peripheral clock stops) | typ. 9 mA @ 5.0V, 20MHZ typ.5 mA @ 3.0V, 10MHZ Typ.35 µA @ 3.0V (Peripheral clock stops) | typ. 9 mA @ 5.0V, 20MHZ typ.5 mA @ 3.0V, 10MHZ Typ.35 µA @ 3.0V (Peripheral clock stops) |
| Wait mode | Typ.0.7 µA @ 3.0V | Typ.0.7 µA @ 3.0V | Typ.0.7 µA @ 3.0V |
| Stop mode | Typ.0.7 µA @ 3.0V | Typ.0.7 µA @ 3.0V | Typ.0.7 µA @ 3.0V |
| Supply voltage | 2.7V to 5.5V | 2.7V to 5.5V | 2.7V to 5.5V |
| Operating temperature | -20°C to +85°C (N version) -40°C to +85°C (D version) -20°C to +105°C(Y version) TBD | -20°C to +85°C (N version) -40°C to +85°C (D version) -20°C to +105°C(Y version) TBD | -20°C to +85°C (N version) -40°C to +85°C (D version) TBD |
| Package | 20 pin SSOP - 0.65mm pitch 28pin QFN - 0.50mm pitch | 20 pin SSOP - 0.65mm pitch 28pin QFN - 0.50mm-pitch | 32 pin LQFP - 0.8mm-pitch |

R8C/ASSP Family

Application Specific Standard Solutions

| Item | R8C/2E-2F | R8C/2K-2L | R8C/2G | R8C/2H | R8C/2J |
|--|--|--|---|---|---|
| Core | R8C core - 16-bit CPU | | | | |
| Flash (byte) | 16K; 8K | | 32K; 24K; 16K | 8K; 4K | 4K; 2K |
| RAM (byte) | 1K; 512 | 1K; 1.5K | 1K; 1K; 512 | 384; 256 | 384; 256 |
| Data Flash (byte) | 2 x 1K (only R8C/2F) | 2 x 1K (only R8C/2L) | no | | |
| Clock circuits | 3 clock circuits with oscillation stop detection - external main clock (Xin, Xout) - internal low speed ring (125KHz) - internal high speed ring (40MHz) | | 3 clock circuits - 32kHz subclock (Xcin, Xcout) - internal low speed ring (125KHz) - internal high speed ring (8MHz) | | 3 clock circuits - internal low speed ring (125KHz) - internal high speed ring (8MHz) |
| f(xin) max. | 20MHz@ 3.0 to 5.5V 10MHz@ 2.7 to 5.5V 125KHz for low speed ring 40MHz for high speed ring (adjustable) | 20MHz@ 3.0 to 5.5V 10MHz@ 2.7 to 5.5V 5MHz@ 2.2 to 5.5V 125KHz for low speed ring 40MHz for high speed ring (adjustable) | 8MHz@ 2.7 to 5.5V (125ns min. instruction) 4MHz@ 2.2 to 5.5V 32KHz - with RTC 125KHz for low speed ring 8MHz for high speed ring (adjustable) | | 8MHz@ 2.7 to 5.5V (125ns min. instruction) 4MHz@ 2.2 to 5.5V 125KHz for low speed ring 8MHz for high speed ring (adjustable) |
| High speed on chip oscillator accuracy | 40MHz on chip oscillator +/-1% => 25°C @5V +/-2% => -20°C to 85°C @ -4.7V to 5.5V | | 8MHz on chip oscillator +/-1% => 25°C @5V +/-3% => 0°C to 60°C @ -4.7V to 5.5V +/-4% => -20°C to 85°C @ -2.7V to 5.5V | | |
| Pins | 32 | | 32 | 16 I/O | 20 |
| I/O ports | 25 I/O+ 3 input | | 28 I/O | | 12 I/O |
| LED direct drive | 8 x 20mA | | | | |
| Internal pull up | all I/O all selectable with pull up resistors | | | | |
| Interrupts | 15 x intern 4 x extern selectable 7 priority level | 15 x intern 4 x extern selectable 7 priority level | 17 x intern 5 x extern selectable 7 priority level | 17 x intern 3 x extern selectable 7 priority level | 14 x intern 3 x extern selectable 7 priority level |
| Timers | 2 x 8bit (RA& RB - with prescaler) 1 x 8bit (RE) | 2 x 8bit (RA& RB - with prescaler) 2 x 16bit (RD - with IC & OC) 1 x 16bit (RC - with IC & OC) | 2 x 8bit (RA& RB - with prescaler) 1 x 8bit (RE - with prescaler one week RTC) 1 x 16bit (RF - with IC & OC) | | 2 x 8bit (RA& RB - with prescaler) |
| Watchdog | 1x 15bit (with independent 125KHz OCO) reset start selection | | | | |
| Analog channels | ADC: 12 x 10bit DA: 2x 8bit Comparator: 2 x (200ns max. response time) | ADC: 9 x 10bit Comparator: 2 x 40µs max. response time (shared with LVD) | Comparator: 2 x 40µs max. response time (shared with LVD) | Comparator: 2 x 40µs max. response time (shared with LVD) | Comparator: 2 x 40µs max. response time (shared with LVD) |
| Serial I/O | 1 x USART (UART0) 1 x LIN (via UART0 + Timer RA) | | 2 x USART (UART0 UART1) 1 x LIN (via UART0 + Timer RA) | | 1 x USART (UART0) 1 x LIN (via UART0 + Timer RA) |
| Others | POR/LVD with three levels Clock stop detection | POR/LVD with three levels Clock stop detection | POR/LVD with three levels | POR/LVD with three levels | POR/LVD with three levels |
| Run- mode | typ. 10 mA @ 5.0V, 20MHZ typ. 6 mA @ 3.0V, 10MHZ | typ. 10 mA @ 5.0V, 20MHZ typ. 6 mA @ 3.0V, 10MHZ | typ. TBD mA @ 5.0V, 8MHZ typ. TBD mA @ 3.0V, 4MHZ | typ. TBD mA @ 5.0V, 8MHZ typ. TBD mA @ 3.0V, 4MHZ | typ. TBD mA @ 5.0V, 8MHZ typ. TBD mA @ 3.0V, 4MHZ |
| Wait mode | a) with int. low speed ring: 25µA @5V (Peripheral clock stops) | a) with int. low speed ring: 25µA @5V (Peripheral clock stops) | a) with int. low speed ring: TBDµA @5V (Peripheral clock stops) | a) with int. low speed ring: TBDµA @5V (Peripheral clock stops) | a) with int. low speed ring: TBDµA @5V (Peripheral clock stops) |
| Stop mode | Typ.0.7 µA @ 3.0V | Typ.0.7 µA @ 3.0V | Typ.TBD µA @ 3.0V | Typ.TBD µA @ 3.0V | Typ.TBD µA @ 3.0V |
| Supply Voltage | 2.7V to 5.5V | | | | |
| Operating temperature | -20°C to +85°C (N version) -40°C to +85°C (D version) -20°C to +105°C (Y version) (TBD) | -20°C to +85°C (N version) -40°C to +85°C (D version) -20°C to +105°C (Y version) (TBD) | -20°C to +85°C (N version) -40°C to +85°C (D version) | -20°C to +85°C (N version) -40°C to +85°C (D version) | -20°C to +85°C (N version) -40°C to +85°C (D version) |
| Package | 32pin LQFP - 0.8mm pin pitch | 32pin LQFP - 0.8mm pin pitch | 32pin LQFP - 0.8mm pin pitch | 20pin SSOP - 0.65mm pin pitch | 20pin SSOP - 0.65mm pin pitch |

R8C/3xA Family

The next generation

| Item | R8C/32 | R8C/33 | R8C35 |
|---|--|---|--|
| Core | R8C core - 16-bit CPU | | |
| Flash memory (byte) | 16K; 8K; 4K | 32K; 24K; 16K; 8K/4K | (128K; 96K; 64K; 32K; 24K; 16K (*1)) |
| RAM (byte) | 1.5K; 1K; 512b | 2.5K; 2K; 1.5K; 1K; 512 | (10K; 8K; 6K; 4K; 2.5K; 2K; 1.5K (*1)) |
| Data Flash (byte) | 4 x 1K (with Background operation) | | |
| Clock circuits | 4 clock circuits with oscillation stop detection - external main clock (Xin, Xout) - 32kHz subclock (Xcin, Xcout) - 2 x internal low speed ring (125kHz) - internal high speed ring (40MHz) | | |
| f(xin) max. | 20MHz@ 3.0 to 5.5V (50ns min. insturction) 10MHz@ 2.7 to 5.5V 5MHz@ 2.2 to 5.5V 2MHz@ 1.8 to 5.5V 32kHz - RTC 125kHz for low speed (2x times) 40MHz for high speed (adjustable) | | |
| High speed on chip oscillator accuracy | 40MHz +/-1% => -20°C to 85°C @ -3.0V to 5.5V | | |
| Pins | 20 | 32 | 52 |
| I/O ports | 15 I/O + 1 input | 27 I/O + 1 input | 47 I/O + 1 input |
| LED direct drive | 15 x 20mA | 27 x 20mA | 47 x 20mA |
| Internal pull up | all I/O all selectable with pull up resistors | | |
| Interrupts | 42 x interrupt vectors 7 x extern; selectable 7 priority level | 44 x interrupt vectors 7 x extern selectable 7 priority level | 48 x interrupt vectors 9 x extern selectable 7 priority level |
| DTC Data Transfer Controller | 1 x channel 21 x sources 2 x transfer modes (normal & repeat mode) | 1 x channel 23 x sources 2 x transfer modes (normal & repeat mode) | 1 x channel 33 x sources 2 x transfer modes (normal & repeat mode) |
| Timers | 2 x 8bit (RA & RB - with prescaler) 1 x 8bit (RE - with prescaler one week RTC) 1 x 16bit (RC with 4 IC & OC) | | 2 x 8bit (RA & RB - with prescaler) 1 x 8bit (RE - with prescaler one week RTC) 1 x 16bit (RC with 4 IC & OC) 2 x 16bit (RD with 2 x 4 IC & OC) |
| Watchdog | 1x 15bit (with independent 125kHz OCO) reset start selection; window function | | |
| Analog channels | ADC: 4 x 10bit (with 8 result registers) 2.15µs Comparator A: 2 x circuits (with LVD) Comparator B: 2 x circuits | ADC: 12 x 10bit (with 8 result registers) 2.15µs DA: 2 x 8bit Comparator A: 2 x circuits (with LVD) Comparator B: 2 x circuits | |
| Serial I/O | 1 x USART (UART0) 1 x UART2 (I2C IE mode multiprocessor,...) 1 x SSUA or I2C 1 x LIN (via UART0 + Timer RA) | 2 x USART (UART0, UART1) 1 x UART2 (I2C IE mode multiprocessor,...) 1 x SSUA or I2C 1 x LIN (via UART0 + Timer RA) | |
| Others | POR/LVD with 3 different circuits (Vdet1; Vdet2; Vdet3); Vdet1 with 16level clock stop detection | | |
| Active - mode | TBD | TBD | TBD |
| Wait mode | TBD µA | TBD µA | TBD µA |
| Stop mode | TBD µA | TBD µA | TBD µA |
| Supply voltage | 1.8V to 5.5V | | |
| Operating temperature | -20°C to +85°C (N version) -40°C to +85°C (D version) | | |
| Package | 20pin SSOP - 0.65mm pin pitch | 32pin LQFP - 0.8mm pin pitch | 52pin LQFP - 0.65mm pin pitch |

(*1) Devices under development. Availability planned Q3/2008. Memory version 4K to 32kbyte
Devices with 64pin; 80pin and memory version up to 128kbyte planned for Q1/2009

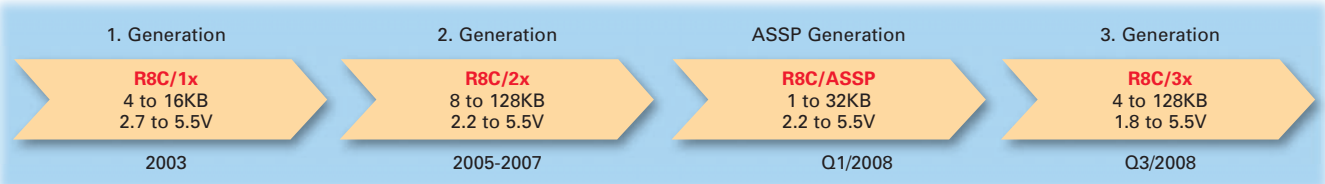

Advanced features

The third generation of R8C/3xA will offer additional performance and more advanced peripherals like Direct Transfer Control (DTC), Dataflash with background operation, more variations on analog interfaces and a 40MHz high speed on-chip oscillator of +/-1% over the temperature range of -20 to +85°C. The voltage range has been expanded to 1.8 to 5.5V. These 16 to 80pin devices are pin compatible within the R8C/3xA family and software compatible to the R8C/2x family.

R8C/3xA Family

Flash: 4KB to 128B (*1)
RAM: 512B to 10KB
Dataflash: 2 x 1K
Vcc: 1.8 to 5.5V

COMING SOON!

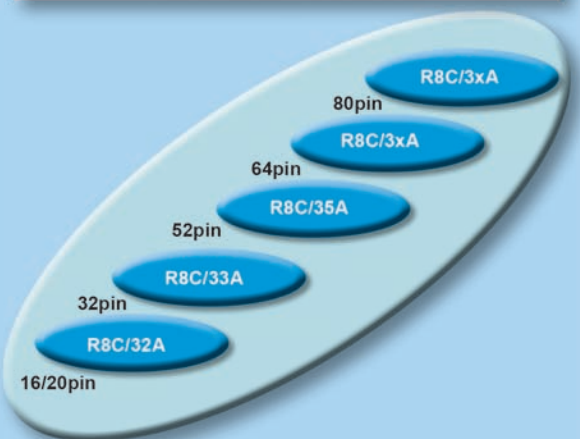

First samples available Q3/2008

R8C/1x and R8C/2x

R8C/1x - Cost efficient

R8C/18-19 and 1A-1B devices

The R8C/18-19 and 1A-1B are the most price aggressive members. It has a lot of different serial interfaces on a 20pin device; embedded Dataflash to substitute external EEproms and is available in two different packages.

- High precision, on-chip oscillator (8MHz)
- Low speed on-chip oscillator (independent clock for WDT)
- On chip multimaster I2C bus and SPI with chip select
- 2 x UART/ UASART
- R8C/1A-1B has AD convert's; R8C/18-19 has comparators
- High current drive ports
- Package: 20pin SSOP 4.4 x 6.5 x 1.45mm; 0.65mm pitch
28pin QFN 5 x 5 x 0.75mm; 0.5mm pitch



R8C/1A-1B

R8C/2x - Upgrade and Downgrade compatible

R8C/28-29 and 26-27 devices

The R8C/28-29 and 26-17 are ideal for applications which require small memory, low pin and low cost. It has a lot of different serial interfaces on a 20pin device; and embedded Dataflash to substitute external EEproms. The 32pin device offers memory sizes up to 3kbyte flash.

- High precision, on-chip oscillator (40MHz @ 1%)
- Low speed on-chip oscillators (independent clock for WDT)
- 3 serial interfaces including U(S)ART; multimaster I2C;
- SPI with chip select and LIN
- 32KHz; Real-time clock with embedded one week timer
- 20pin with 16 I/Os and 32pin with 28 I/Os
- High current drive ports & overcurrent detection
- Package: 20pin SSOP - 4.4 x 6.5 x 1.45mm; 0.65mm pitch
32pin LQFP - 7 x 7 x 1.7mm; 0.8mm pitch

(*2) automotive versions are available -40 to 85°C/125°C



R8C/26-27

R8C/24-25 devices

The R8C/24-25 general purpose device is suitable for a wide range of applications. This device offers a powerful solution for low-end motor control applications or can drive up to 8x16-bit PWM. As these are compatible to the R8C/26-29 devices, it is easy to upgrade for more performance and flash size up to 64kbyte.

- High precision, on chip oscillator (40MHz @ 1%)
- Low speed on chip oscillators (independent clock for WDT)
- 16-bit Timer RD for Motor control (e.g. 3ph with dead time)
- 3 serial interfaces including U(S)ART; multimaster I2C;
- SPI with chip select and LIN
- 32KHz; Real time clock (RTC) with embedded one week timer
- High current drive ports & overcurrent detection
- Package: 52pin LQFP - 10 x 10 x 1.7 mm; 0.65mm pitch
64pin LGA - 6 x 6 x 1.05 mm; 0.65mm pitch



R8C/24-25

R8C/2x - Upgrade and Downgrade compatible

R8C/22-23 devices

The R8C/22-23 devices are pin compatible to the R8C/24-25 and have the same powerful 16-bit timers to drive low-end motor control applications. In addition these have the CAN module. These devices has been designed to support low end industry and automotive applications, requiring CAN.

- High precision, on-chip oscillator (40MHz @ 1% calibrated)
 - Low speed on-chip oscillators (independent clock for WDT)
 - 16-bit Timer RD for Motor control (e.g. 3ph with dead time)
 - 1 x CAN 2.0B (16 slots)
 - Package: 48pin LQFP - 7 x 7x 1.7mm; 0.5mm pitch
 - Temperature range: industry spec. -40 to 85°C
- (*) automotive versions are available -40 to 125°C
higher memory versions – up to 128kbyte are available on the automotive devices



R8C/22-23

R8C/2x - Upgrade and Downgrade compatible

R8C/2A-2D devices

The R8C/2A-2B are 64pin and R8C/2C-2D are 80pin general purpose devices, suitable for a wide range of applications. These devices offer an easy upgrade for applications which need more I/O pins; up to 20 ADC (on 80pin) and memory sizes up to 128kbyte.

- High precision, on-chip oscillator (40MHz @ 1% calibrated)
- Low speed on-chip oscillators (independent clock for WDT)
- 16-bit Timer RD for Motor control (e.g. 3ph with dead time)
- High-current drive ports & over current detection
- DA converter and ADC with scan function (4 result registers)
- Package: 64pin LQFP -10 x 10 x 1.7mm; 0.5mm pitch
64pin LQFP - 14 x 14 x 1.7mm; 0.8mm pitch
80pin LQFP - 12 x 12 x 1.7mm; 0.5mm pitch



R8C/2A-2D

R8C Packages

20pin SSOP
4.4 x 6.5 x 1.45mm
0.65mm pitch



R8C/18 R8C/1B
R8C/19 R8C/28
R8C/1A R8C/29

28pin QFN
5 x 5 x 0.75mm
0.5mm pitch



R8C/18 R8C/1A
R8C/19 R8C/1B

32pin LQFP
7 x 7 x 1.7mm
0.8mm pitch



R8C/11 R8C/26
R8C/13 R8C/27

48pin LQFP
7 x 7 x 1.7mm
0.5mm pitch



R8C/20 R8C/20
R8C/21 R8C/21

52pin LQFP
10 x 10 x 1.7 mm
0.65mm pitch



R8C/24 R8C/25

64pin LGA
6 x 6 x 1.05 mm
0.65mm pitch



R8C/24
R8C/25

64pin LQFP
10 x 10 x 1.7mm
0.5mm pitch



R8C/2A
R8C/2B

64pin LQFP
14 x 14 x 1.7mm
0.8mm pitch



R8C/2A
R8C/2B

80pin LQFP
12 x 12 x 1.7mm
0.5mm pitch



R8C/2C
R8C/2D

R8C/ASSP - Application Specific Standard Devices

R8C/ASSP – Application Specific Standard Devices

R8C/2E-2F devices

The R8C/2E-2F devices are based on the well known R8C/2x family, therefore they are software and pin compatible to the 32pin R8C/26-27. The R8C/2E-2F has been designed to offer a lot of analog functions like comparators (with output pin), A/D and D/A converters on one chip. The D/A converters can be used as Vref for the comparators. This device is especially suited to lighting and beamer applications.

- High precision, on-chip oscillator (40MHz @ 1%)
- Low speed on-chip oscillators (independent clock for WDT)
- High-current drive ports
- 12 x Input AD converter; 2 x Input DA converter and 2 x comparators
- Package: 32pin LQFP - 7 x 7 x 1.7mm; 0.8mm pitch

R8C/2K-2L devices

The R8C/2K-2L are downgrades of the 52pin R8C/25 and 64pin R8C/2B. The R8C/2K-2L have 32pins and offer an excellent solution for many low-end motor control applications, which need small packages and smaller memory sizes.

- High precision, on-chip oscillator (40MHz @ 1%)
- Low speed on-chip oscillators (independent clock for WDT)
- 16bit Timer RD for motor control (e.g. 3ph with dead time)
- additional 16-bit Timer RC for back EMF
- 2 x UA(S)RT
- High-current drive ports & overcurrent detection
- Packages: 32pin LQFP - 7 x 7 x 1.7mm; 0.8mm pitch

R8C/2J device (*1)

The R8C/2J offers the most aggressive price on the high performance 16-bit R8C family. With two internal high/low oscillator; 1 x USART, 2x8bit and one 16-bit timers it has been designed for low cost and small appliances, where 2K and 4kbyte flash are enough. Nevertheless, this device has still a hardware multiplier, POR/LVD and circuits clock-stop detection. Pin compatible to the other 20pin devices makes it easy to switch to the R8C/18-1B and R8C/28-29 which offers more features and memory.

- High precision, on-chip oscillator (8MHz)
- Low speed on-chip oscillators (independent clock for WDT)
- 2 and 4kbyte flash
- 16pin with 12 I/Os
- High current drive ports
- Package: 20pin SSOP - 4.4 x 6.5 x 1.45mm; 0.65mm pitch

(*1) Device under development
Availability planned for end Q2/2008



R8C/2E-2F



R8C/2K-2L



R8C/2J

Tools



R8C Tool

A reliable, integrated development environment is essential in today's "fastest time-to-market" engineering climate. Wherever you are looking, the Renesas R8C Platform support tool chain provides a fitting tool to meet your requirements and speeds up the design time to market. Furthermore these tools can be reused for any other future development with a R8C Platform device.

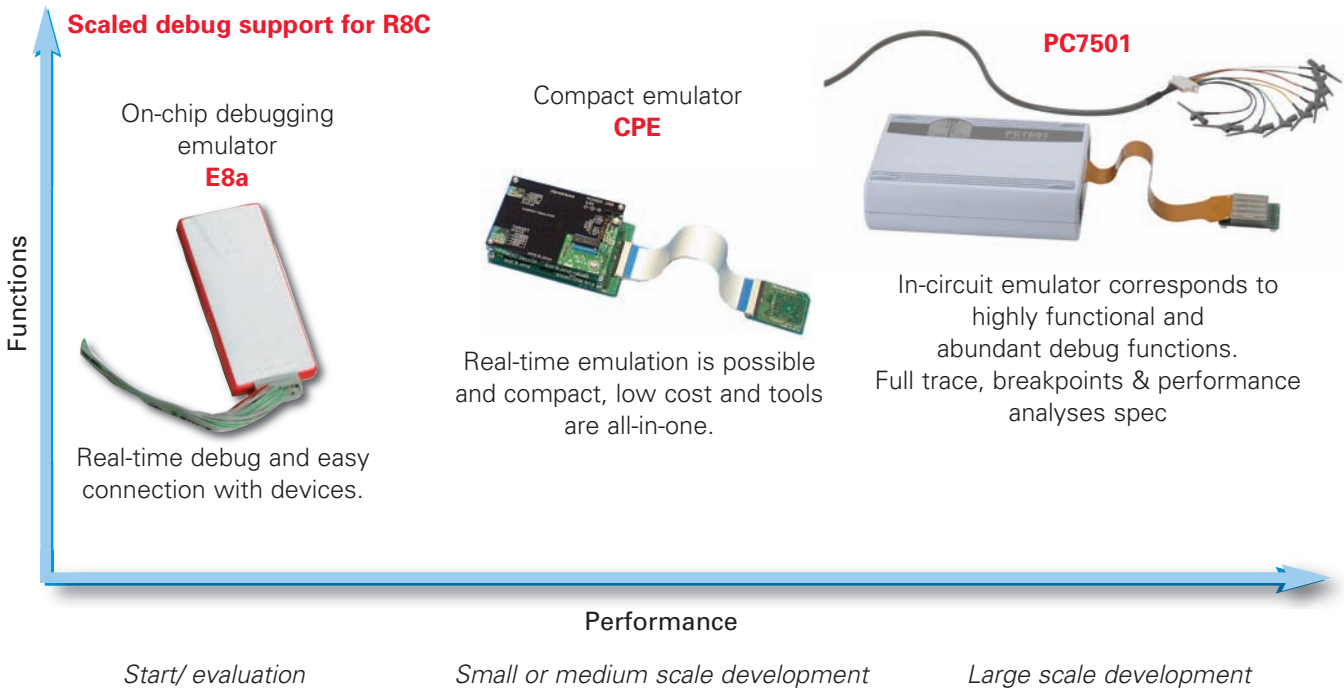

Compilers

The key for any embedded development is the tool chain. Renesas Technology Europe has a number of different approaches to ensure that we offer the very best solutions to support you during your design. The selection ranges from supported third-party compilers, free of charge GNU compiler and our own in-house compiler.

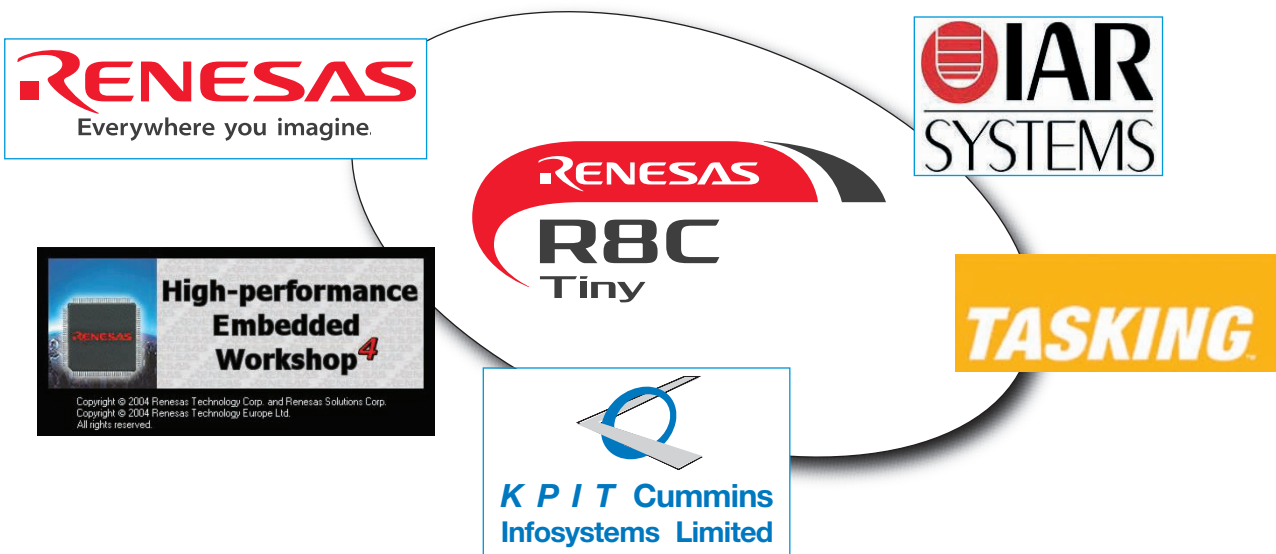

Tools Tools

High-performance Embedded Workshop

Renesas has developed a fully integrated development environment known as HEW (High-performance Embedded Workshop). HEW pulls together all of the development tasks into one easy-to-use application.

- Code development
- Project management
- Integrated debugger
- Compiler integration
- Flash programmer



| Group | Compact Emulator including CPE + Converter board | Full Emulator System | | Starter Kits | On-Chip Debugger | Renesas Flasher SW | Software Development Environment | Renesas Compiler | Renesas Debugger |
|--------------------------|--|----------------------|--|-------------------|------------------|--------------------|----------------------------------|---|------------------|
| | | Emulator | Probe - including Probe + Converter board | | | | | | |
| R8C/1X GENERATION | | | | | | | | | |
| R8C/18191A1B | R0E521174CPE00 (20pin) | | R0E521174EPB00 (20pin) | R0K5211B4S001BE | | | | | |
| R8C/2X GENERATION | | | | | | | | | |
| R8C/22-23 | R0E521237CPE00 (48pin) | | R0E521237EPB00 (48pin) | R0K521237S000BE | | | | | |
| R8C/24-25 | R0E521258CPE00 (52pin) | | R0E521258EPB00 (52pin) | R0K521256S001BE | | | | NC30WA - compiler | |
| R8C/26-27 | R0E521276CPE00 (32pin) | | R0E521276EPB00 (32pin) | R0K521276S001BE | | | | Singel user (one node): S32HEWNC30-1-18 S32HEWNC30-1-18 | |
| R8C/28-29 | R0E521174CPE00 (20pin) | | R0E521174EPB00 (20pin) | - | | | | Singel user:(Network) S32HEWNC30-N1-6 S32HEWNC30-N1-18 | |
| R8C/2A-2B | R0E5212BACPE00 (64pin) R0E5212BACPE10 (64pin) | | R0E5212BAEPB00 (64pin) R0E5212BAEPB10 (64pin) | - | | | | Five users (node): S32HEWNC30-5-6 S32HEWNC30-5-18 | |
| R8C/2C-2D | R0E5212DACPE00 (80pin) | | R0E5212DAEPB10 (80pin) | R0K5212D6S001BE | | | | Five users (Network): S32HEWNC30-N5-6 S32HEWNC30-N5-18 | |
| R8C/ASSP | | | | | | | | | |
| R8C/2K-2L | R0E5212L4CPE00 (32pin) | | R0E5212L4EPB00 | - | | | | | |
| R8C/2E-2F | - | - | - | under development | | | | | |
| R8C/2J | - | - | - | - | | | | | |
| R8C/3X GENERATION | | | | | | | | | |
| R8C/3x | E100 | E100 | | under development | | | | | |

Renesas Starter Kits (RSK)



RSK – Renesas StarterKit

The R8C Starter Kit includes:

- CPU board with target microcontroller
- LCD panel for user/diagnostic interaction
- E8a On Chip Debugger
- Trial C compiler and IDE
- Tutorial session
- Sample peripheral codes



Useful Links

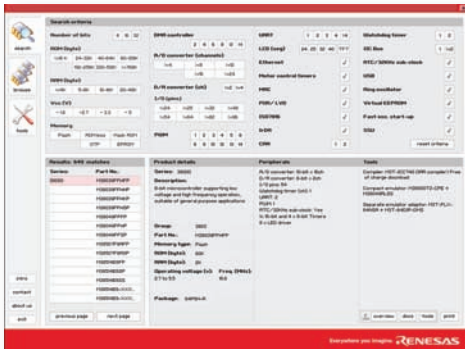

Discover the **Renesas Microchooser**: Free Microcontroller parametric search tool. Select from over 500 Flash microcontrollers using the Renesas interactive Microchooser™. This is the ultimate parametric search tool for 8, 16, and 32-bit microcontrollers, combining ease of use with instant results.
www.microchooser.com



www.renesasinteractive.com
Your convenient on-line environment for a wide range of semiconductor devices research, evaluation and application. Use the free Renesas on-line support service for focused learning and evaluation of Renesas microcontrollers in our virtual engineering lab.

www.renesas.com
The Renesas Global website allows you to access details on the entire Renesas product range including application notes, new software tools and much more.

The home page can be accessed from either: www.renesas.eu or www.eu.renesas.com

