



MCF5206e
ColdFire[®]
Integrated Microprocessor
User's Manual

Motorola reserves the right to make changes without further notice to any products herein. Motorola makes no warranty, representation or guarantee regarding the suitability of its products for any particular purpose, nor does Motorola assume any liability arising out of the application or use of any product or circuit, and specifically disclaims any and all liability, including without limitation consequential or incidental damages. "Typical" parameters can and do vary in different applications. All operating parameters, including "Typicals" must be validated for each customer application by customer's technical experts. Motorola does not convey any license under its patent rights nor the rights of others. Motorola products are not designed, intended, or authorized for use as components in systems intended for surgical implant into the body, or other applications intended to support or sustain life, or for any other application in which the failure of the Motorola product could create a situation where personal injury or death may occur. Should Buyer purchase or use Motorola products for any such unintended or unauthorized application, Buyer shall indemnify and hold Motorola and its officers, employees, subsidiaries, affiliates, and distributors harmless against all claims, costs, damages, and expenses, and reasonable attorney fees arising out of, directly or indirectly, any claim of personal injury or death associated with such unintended or unauthorized use, even if such claim alleges that Motorola was negligent regarding the design or manufacture of the part. Motorola and  are registered trademarks of Motorola, Inc. Motorola, Inc. is an Equal Opportunity/Affirmative Action Employer.

Freescale Semiconductor, Inc.

Freescale Semiconductor, Inc.

ColdFire is a Registered Trademark of Motorola, Inc. All other trademarks reside with their respective owners.

**For More Information On This Product,
Go to: www.freescale.com**

DOCUMENTATION FEEDBACK

**FAX 512-891-8593—Documentation Comments Only (no technical questions please)
http: // www.mot.com/hpesd/docs_survey.html—Documentation Feedback Only**

The Technical Communications Department welcomes your suggestions for improving our documentation and encourages you to complete the documentation feedback form at the World Wide Web address listed above. In return for your efforts, you will receive a small token of our appreciation. Your help helps us measure how well we are serving your information requirements.

The Technical Communications Department also provides a fax number for you to submit any questions or comments about this document or how to order other documents. Please provide the part number and revision number (located in upper right-hand corner of the cover) and the title of the document. When referring to items in the manual, please reference by the page number, paragraph number, figure number, table number, and line number if needed. **Please do not fax technical questions to this number.**

When sending a fax, please provide your name, company, fax number, and phone number including area code.

For Internet Access:

Web Only: [http: // www.motorola.com/coldfire](http://www.motorola.com/coldfire)

For Hotline Questions:

FAX (US or Canada): 1-800-248-8567

Freescale Semiconductor, Inc.

Applications and Technical Information

For questions or comments pertaining to technical information, questions, and applications, please contact one of the following sales offices nearest you.

— Sales Offices —

Field Applications Engineering Available Through All Sales Offices

UNITED STATES

ALABAMA, Huntsville (205) 464-6800
ARIZONA, Tempe (602) 897-5056
CALIFORNIA, Agoura Hills (818) 706-1929
CALIFORNIA, Los Angeles (310) 417-8848
CALIFORNIA, Irvine (714) 753-7360
CALIFORNIA, Roseville (916) 922-7152
CALIFORNIA, San Diego (619) 541-2163
CALIFORNIA, Sunnyvale (408) 749-0510
COLORADO, Colorado Springs (719) 599-7497
COLORADO, Denver (303) 337-3434
CONNECTICUT, Wallingford (203) 949-4100
FLORIDA, Maitland (407) 628-2636
FLORIDA, Pompano Beach/
Fort Lauderdale (305) 486-9776
FLORIDA, Clearwater (813) 538-7750
GEORGIA, Atlanta (404) 729-7100
IDAHO, Boise (208) 323-9413
ILLINOIS, Chicago/Hoffman Estates (708) 490-9500
INDIANA, Fort Wayne (219) 436-5818
INDIANA, Indianapolis (317) 571-0400
INDIANA, Kokomo (317) 457-6634
IOWA, Cedar Rapids (319) 373-1328
KANSAS, Kansas City/Mission (913) 451-8555
MARYLAND, Columbia (410) 381-1570
MASSACHUSETTS, Marlborough (508) 481-8100
MASSACHUSETTS, Woburn (617) 932-9700
MICHIGAN, Detroit (313) 347-6800
MINNESOTA, Minnetonka (612) 932-1500
MISSOURI, St. Louis (314) 275-7380
NEW JERSEY, Fairfield (201) 808-2400
NEW YORK, Fairport (716) 425-4000
NEW YORK, Hauppauge (516) 361-7000
NEW YORK, Poughkeepsie/Fishkill (914) 473-8102
NORTH CAROLINA, Raleigh (919) 870-4355
OHIO, Cleveland (216) 349-3100
OHIO, Columbus/Worthington (614) 431-8492
OHIO, Dayton (513) 495-6800
OKLAHOMA, Tulsa (800) 544-9496
OREGON, Portland (503) 641-3681
PENNSYLVANIA, Colmar (215) 997-1020
Philadelphia/Horsham (215) 957-4100
TENNESSEE, Knoxville (615) 584-4841
TEXAS, Austin (512) 873-2000
TEXAS, Houston (800) 343-2692
TEXAS, Plano (214) 516-5100
VIRGINIA, Richmond (804) 285-2100
WASHINGTON, Bellevue (206) 454-4160
Seattle Access (206) 622-9960
WISCONSIN, Milwaukee/Brookfield (414) 792-0122

CANADA

BRITISH COLUMBIA, Vancouver (604) 293-7605
ONTARIO, Toronto (416) 497-8181
ONTARIO, Ottawa (613) 226-3491
QUEBEC, Montreal (514) 731-6881

INTERNATIONAL

AUSTRALIA, Melbourne (61-3)887-0711
AUSTRALIA, Sydney (61-2)906-3855
BRAZIL, Sao Paulo 55(11)815-4200
CHINA, Beijing 86 505-2180
FINLAND, Helsinki 358-0-35161191
Car Phone 358(49)211501
FRANCE, Paris/Varves 33(1)40 955 900

GERMANY, Langenhagen/ Hanover 49(511)789911
GERMANY, Munich 49 89 92103-0
GERMANY, Nuremberg 49 911 64-3044
GERMANY, Sindelfingen 49 7031 69 910
GERMANY, Wiesbaden 49 611 761921
HONG KONG, Kwai Fong 852-4808333
Tai Po 852-6668333
INDIA, Bangalore (91-812)627094
ISRAEL, Tel Aviv 972(3)753-8222
ITALY, Milan 39(2)82201
JAPAN, Aizu 81(241)272231
JAPAN, Atsugi 81(0462)23-0761
JAPAN, Kumagaya 81(0485)26-2600
JAPAN, Kyushu 81(092)771-4212
JAPAN, Mito 81(0292)26-2340
JAPAN, Nagoya 81(052)232-1621
JAPAN, Osaka 81(06)305-1801
JAPAN, Sendai 81(22)268-4333
JAPAN, Tachikawa 81(0425)23-6700
JAPAN, Tokyo 81(03)3440-3311
JAPAN, Yokohama 81(045)472-2751
KOREA, Pusan 82(51)4635-035
KOREA, Seoul 82(2)554-5188
MALAYSIA, Penang 60(4)374514
MEXICO, Mexico City 52(5)282-2864
MEXICO, Guadalajara 52(36)21-8977
Marketing 52(36)21-9023
Customer Service 52(36)669-9160
NETHERLANDS, Best (31)49988 612 11
PUERTO RICO, San Juan (809)793-2170
SINGAPORE (65)2945438
SPAIN, Madrid 34(1)457-8204
or 34(1)457-8254
SWEDEN, Solna 46(8)734-8800
SWITZERLAND, Geneva 41(22)7991111
SWITZERLAND, Zurich 41(1)730 4074
TAIWAN, Taipei 886(2)717-7089
THAILAND, Bangkok (66-2)254-4910
UNITED KINGDOM, Aylesbury 44(296)395-252

FULL LINE REPRESENTATIVES

COLORADO, Grand Junction
Cheryl Lee Whitely (303) 243-9658
KANSAS, Wichita
Melinda Shores/Kelly Greiving (316) 838 0190
NEVADA, Reno
Galena Technology Group (702) 746 0642
NEW MEXICO, Albuquerque
S&S Technologies, Inc. (505) 298-7177
UTAH, Salt Lake City
Utah Component Sales, Inc. (801) 561-5099
WASHINGTON, Spokane
Doug Kenley (509) 924-2322
ARGENTINA, Buenos Aires
Argonics, S.A. (541) 343-1787

HYBRID COMPONENTS RESELLERS

Elmo Semiconductor (818) 768-7400
Minco Technology Labs Inc. (512) 834-2022
Semi Dice Inc. (310) 594-4631

PREFACE

The *MCF5206e ColdFire® Integrated Microprocessor User's Manual* describes the programming, capabilities, and operation of the MCF5206e device. Refer to the *ColdFire Family Programmer's Reference Manual Rev 1.0* (MCF5200PRMREV1/D) for information on the ColdFire Family of microprocessors.

CONTENTS

This user manual is organized as follows:

- Section 1: Introduction
- Section 2: Signal Description
- Section 3: ColdFire Core
- Section 4: Instruction Cache
- Section 5: SRAM
- Section 6: Bus Operation
- Section 7: DMA Controller Module
- Section 8: System Integration Module (SIM)
- Section 9: Chip-Select Module
- Section 10: Parallel Port (General-Purpose I/O) Module
- Section 11: DRAM Controller
- Section 12: UART Modules
- Section 13: M-Bus Module
- Section 14: Timer Module
- Section 15: Debug Support
- Section 16: IEEE 1149.1 Test Access Port (JTAG)
- Section 17: Electrical Characteristics
- Section 18: Mechanical Characteristics
- Appendix A: MCF5206e Memory Map
- Appendix B: Porting from M68000
- Index

Freescale Semiconductor, Inc.

Introduction	1
Signal Description	2
ColdFire Core	3
Instruction Cache	4
SRAM	5
Bus Operation	6
DMA Controller Module	7
System Integration Module (SIM)	8
Chip Select Module	9
Parallel Port (General-Purpose I/O)	10
DRAM Controller	11
UART Modules	12
MBus Module	13
Timer Module	14
Debug Support	15
IEEE 1149.1 JTAG	16
Electrical Characteristics	17
Mechanical Characteristics	18
Appendix A: MCF5206e Memory Map	A
Appendix B: Porting from M68000	B

Freescale Semiconductor, Inc.

- | | |
|-----------|--|
| 1 | Introduction |
| 2 | Signal Description |
| 3 | ColdFire Core |
| 4 | Instruction Cache |
| 5 | SRAM |
| 6 | Bus Operation |
| 7 | DMA Controller Module |
| 8 | System Integration Module (SIM) |
| 9 | Chip Select Module |
| 10 | Parallel Port (General-Purpose I/O) |
| 11 | DRAM Controller |
| 12 | UART Modules |
| 13 | M-Bus Module |
| 14 | Timer Module |
| 15 | Debug Support |
| 16 | IEEE 1149.1 JTAG |
| 17 | Electrical Characteristics |
| 18 | Mechanical Characteristics |
| A | Appendix A: MCF5206e Memory Map |
| B | Appendix B: Porting from M68000 |

TABLE OF CONTENTS

Paragraph Number	Title	Page Number
---------------------	-------	----------------

Section 1 Introduction

1.1	Background	1-1
1.2	MCF5206e Features	1-2
1.3	Functional Blocks	1-4
1.3.1	ColdFire Processor Core	1-5
1.3.1.1	Processor States	1-6
1.3.1.2	Programming Model	1-6
1.3.1.3	MAC Registers Summary	1-10
1.3.1.4	Addressing Capabilities Summary	1-10
1.3.1.5	Instruction Set Overview	1-10
1.3.2	MAC Module	1-15
1.3.3	Hardware Divide Module	1-15
1.3.4	Instruction Cache	1-15
1.3.5	Internal SRAM	1-15
1.3.6	DRAM Controller	1-16
1.3.7	Direct Memory Access (DMA)	1-16
1.3.8	UART Modules	1-16
1.3.9	Timer Module	1-16
1.3.10	Motorola Bus (M-Bus) Module	1-16
1.3.11	System Interface	1-17
1.3.11.1	External Bus Interface	1-17
1.3.11.2	Chip Selects	1-17
1.3.12	8-Bit Parallel Port (General Purpose I/O)	1-17
1.3.13	Interrupt Controller	1-17
1.3.14	System Protection	1-18
1.3.15	JTAG	1-18
1.3.16	System Debug Interface	1-18
1.3.17	Pinout and Package	1-18

Section 2 Signal Description

2.1	Introduction	2-1
2.2	Address Bus	2-3
2.2.1	Address Bus (A[27:24]/ CS[7:4]/ WE[0:3])	2-4
2.2.2	Address Bus (A[23:0])	2-4
2.2.3	Data Bus (D[31:0])	2-4

TABLE OF CONTENTS (Continued)

Paragraph Number	Title	Page Number
2.3	Chip Selects	2-4
2.3.1	Chip Selects (A[27:24]/ CS[7:4]/ WE[0:3])	2-5
2.3.2	Chip Selects (CS[3:0])	2-5
2.3.3	Byte Write Enables (A[27:24]/ CS[7:4]/ WE[0:3])	2-5
2.4	Interrupt control signals	2-5
2.4.1	Interrupt Priority Level/ Interrupt Request	2-7
2.5	Bus Control Signals	2-8
2.5.1	Read/Write (R/W) Signal	2-8
2.5.2	Size (SIZ[1:0])	2-9
2.5.3	Transfer Type (TT[1:0])	2-9
2.5.4	Access Type and Mode (ATM)	2-9
2.5.5	Transfer Start (TS)	2-10
2.5.6	Transfer Acknowledge (TA)	2-10
2.5.7	Asynchronous Transfer Acknowledge (ATA)	2-10
2.5.8	Transfer Error Acknowledge (TEA)	2-11
2.6	Bus Arbitration Signals	2-11
2.6.1	Bus Request (BR)	2-11
2.6.2	Bus Grant (BG)	2-11
2.6.3	Bus Driven (BD)	2-12
2.7	Clock and Reset Signals	2-12
2.7.1	Clock Input (CLK)	2-12
2.7.2	Reset (RSTI)	2-12
2.7.3	Reset Out (RTS[2]/RSTO)	2-12
2.8	DRAM Controller Signals	2-13
2.8.1	Row Address Strokes (RAS[1:0])	2-13
2.8.2	Column Address Strokes (CAS[3:0])	2-13
2.8.3	DRAM Write (DRAMW)	2-14
2.9	UART Module Signals	2-14
2.9.1	Receive Data (RxD[1], RxD[2])	2-14
2.9.2	Transmit Data (TxD[1], TxD[2])	2-15
2.9.3	Request To Send (RTS[1], RTS[2]/RSTO)	2-15
2.9.4	Clear To Send (CTS[1], CTS[2])	2-15
2.10	Timer Module Signals	2-15
2.10.1	Timer Input (TIN[2], TIN[1])	2-15
2.10.2	Timer Output (TOUT[2], TOUT[1])	2-15
2.11	DMA Module Signals	2-15
2.11.1	DMA Request (DREQ[0], DREQ[1])	2-15
2.12	M-Bus Module Signals	2-16
2.12.1	M-Bus Serial Clock (SCL)	2-16
2.12.2	M-Bus Serial Data (SDA)	2-16
2.13	General Purpose I/O Signals	2-16
2.13.1	General Purpose I/O (PP[7:4]/PST[3:0])	2-16

TABLE OF CONTENTS (Continued)

Paragraph Number	Title	Page Number
2.13.2	Parallel Port (General-Purpose I/O) (PP[3:0]/DDATA[3:0])	2-16
2.14	Debug Support Signals	2-16
2.14.1	Processor Status (PP[7:4]/PST[3:0])	2-16
2.14.2	Debug Data (PP[3:0]/DDATA[3:0])	2-17
2.14.3	Development Serial Clock (TRST/DSCLK)	2-17
2.14.4	Break Point (TMS/BKPT)	2-18
2.14.5	Development Serial Input (TDI/DSI)	2-18
2.14.6	Development Serial Output (TDO/DSO)	2-18
2.15	JTAG Signals	2-18
2.15.1	Test Clock (TCK)	2-18
2.15.2	Test Reset (TRST/DSCLK)	2-18
2.15.3	Test Mode Select (TMS/BKPT)	2-19
2.15.4	Test Data Input (TDI/DSI)	2-19
2.15.5	Test Data Output (TDO/DSO)	2-19
2.16	Test Signals	2-20
2.16.1	Motorola Test Mode (MTMOD)	2-20
2.16.2	High Impedance (HIZ)	2-20
2.17	Signal Summary	2-20

Section 3 ColdFire Core

3.1	Processor Pipelines	3-1
3.2	Processor Register Description	3-2
3.2.1	User Programming Model	3-2
3.2.1.1	Data Registers (D0–D7)	3-2
3.2.1.2	Address Registers (A0–A6)	3-2
3.2.1.3	Stack Pointer (A7)	3-2
3.2.1.4	Program Counter	3-2
3.2.1.5	Condition Code Register	3-3
3.2.2	MAC Unit User Programming Model	3-4
3.2.3	Hardware Divide Module	3-4
3.2.4	Supervisor Programming Model	3-4
3.2.4.1	Status Register	3-4
3.2.4.2	Vector Base Register (VBR)	3-5
3.3	Exception Processing Overview	3-5
3.4	Exception Stack Frame Definition	3-7
3.5	Processor Exceptions	3-8
3.5.1	Access Error Exception	3-8
3.5.2	Address Error Exception	3-9
3.5.3	Illegal Instruction Exception	3-9
3.5.4	Privilege Violation	3-9

TABLE OF CONTENTS (Continued)

Paragraph Number	Title	Page Number
3.5.5	Trace Exception	3-9
3.5.6	Debug Interrupt	3-10
3.5.7	RTE and Format Error Exceptions	3-10
3.5.8	TRAP Instruction Exceptions	3-10
3.5.9	Interrupt Exception	3-10
3.5.10	Fault-on-Fault Halt	3-11
3.5.11	Reset Exception	3-11
3.6	Instruction Execution Timing	3-11
3.6.1	Timing Assumptions	3-11
3.6.2	MOVE Instruction Execution Times	3-12

Section 4 Instruction Cache

4.1	Features of Instruction Cache	4-1
4.2	Instruction Cache Physical Organization	4-1
4.3	Instruction Cache Operation	4-2
4.3.1	Interaction With Other Modules	4-3
4.3.2	Memory Reference Attributes	4-3
4.3.3	Cache Coherency and Invalidation	4-3
4.3.4	Reset	4-4
4.3.5	Cache Miss Fetch Algorithm/Line Fills	4-4
4.4	Instruction Cache Programming Model	4-5
4.4.1	Instruction Cache Registers Memory Map	4-5
4.4.2	Instruction Cache Register	4-6
4.4.2.1	Cache Control Register (CACR)	4-6
4.4.2.2	Access Control Registers (ACR0, ACR1)	4-8

Section 5 SRAM

5.1	SRAM Features	5-1
5.2	SRAM Operation	5-1
5.3	Programming Model	5-1
5.3.1	SRAM Register Memory Map	5-1
5.3.2	SRAM Register	5-2
5.3.2.1	SRAM Base Address Register (RAMBAR)	5-2
5.3.3	SRAM Initialization	5-3
5.3.4	Power Management	5-4

TABLE OF CONTENTS (Continued)

Paragraph Number	Title	Page Number
Section 6		
Bus Operation		
6.1	Features	6-1
6.2	Bus and Control Signals	6-1
6.2.1	Address Bus (A[27:0])	6-1
6.2.2	Data Bus (D[31:0])	6-2
6.2.3	Transfer Start (TS)	6-2
6.2.4	Read/Write (R/W)	6-2
6.2.5	Size (SIZ[1:0])	6-2
6.2.6	Transfer Type (TT[1:0])	6-3
6.2.7	Access Type and Mode (ATM)	6-3
6.2.8	Asynchronous Transfer Acknowledge (ATA)	6-4
6.2.9	Transfer Acknowledge (TA)	6-4
6.2.10	Transfer Error Acknowledge (TEA)	6-5
6.3	Bus Exceptions	6-5
6.3.1	Double Bus Fault	6-5
6.4	Bus Characteristics	6-5
6.5	Data Transfer Mechanism	6-6
6.5.1	Bus Sizing	6-7
6.5.2	Bursting Read Transfers: Word, Longword, and Line	6-16
6.5.3	Bursting Write Transfers: Word, Longword, and Line	6-19
6.5.4	Burst-Inhibited Read Transfer: Word, Longword, and Line	6-22
6.5.5	Burst-Inhibited Write Transfer: Word, Longword, and Line	6-26
6.5.6	Asynchronous-Acknowledge Read Transfer	6-29
6.5.7	Asynchronous Acknowledge Write Transfer	6-32
6.5.8	Bursting Read Transfers with Asynchronous Acknowledge	6-34
6.5.9	Bursting Write Transfers with Asynchronous Acknowledge	6-37
6.5.10	Burst-Inhibited Read Transfers with Asynch. Acknowledge	6-41
6.5.11	Burst-Inhibited Write Transfers with Asynch. Acknowledge	6-44
6.5.12	Termination Tied to GND	6-47
6.6	Misaligned Operands	6-48
6.7	Acknowledge Cycles	6-49
6.7.1	Interrupt Acknowledge Cycle	6-50
6.8	Bus Errors	6-52
6.9	Bus Arbitration	6-54
6.9.1	Two Master Bus Arbitration Protocol (Two-Wire Mode)	6-54
6.9.2	Multiple Bus Master Arbitration Protocol (Three-Wire Mode)	6-61
6.10	External Bus Master Operation	6-67
6.10.1	External Master Read Transfer	6-69
6.10.2	External Master Write Transfer	6-72
6.10.3	External Master Bursting Read	6-74
6.10.4	External Master Bursting Write	6-77

TABLE OF CONTENTS (Continued)

Paragraph Number	Title	Page Number
6.11	Reset Operation	6-81
6.11.1	Master Reset.....	6-81
6.11.2	Normal reset	6-83
6.11.3	Software Watchdog Timer Reset Operation	6-84

Section 7 DMA Controller Module

7.1	Introduction	7-1
7.2	DMA Signal Description	7-3
7.3	DMA Module Overview	7-3
7.4	DMA Controller Module Programming Model	7-6
7.4.1	Source Address Register (SAR)	7-6
7.4.2	Destination Address Register (DAR)	7-7
7.4.3	Byte Count Register (BCR)	7-7
7.4.4	DMA Control Register	7-8
7.4.5	DMA Status Register (DSR)	7-10
7.4.6	DMA Interrupt Vector Register	7-12
7.5	Transfer Request Generation	7-12
7.5.1	Cycle Steal Mode	7-12
7.5.2	Continuous Mode	7-12
7.6	Data Transfer Modes	7-13
7.6.1	Single Address Transactions	7-13
7.6.2	Dual Address Transactions	7-13
7.6.2.1	Dual Address Reads	7-13
7.6.2.2	Dual Address Writes	7-13
7.7	DMA Controller Module Functional Description	7-14
7.7.1	Channel Initialization and Startup	7-14
7.7.1.1	Channel Prioritization	7-14
7.7.1.2	Programming the DMA Controller Module	7-14
7.7.2	Data Transfers	7-15
7.7.2.1	External DMA Request Operation	7-15
7.7.2.2	Auto-Alignment	7-16
7.7.2.3	BandWidth Control	7-17
7.7.3	Channel Termination	7-17
7.7.3.1	Error Conditions	7-17
7.7.3.2	Interrupts	7-17

Section 8 System Integration Module

8.1	Introduction	8-1
-----	--------------------	-----

TABLE OF CONTENTS (Continued)

Paragraph Number	Title	Page Number
8.1.1	Features	8-1
8.2	SIM Operation	8-1
8.2.1	Module Base Address Register (MBAR)	8-1
8.2.2	Bus Timeout Monitor	8-2
8.2.3	Spurious Interrupt Monitor	8-2
8.2.4	Software Watchdog Timer	8-3
8.2.5	Interrupt Controller	8-3
8.3	Programming Model	8-6
8.3.1	SIM Registers Memory Map	8-6
8.3.2	SIM Registers	8-7
8.3.2.1	Module Base Address Register (MBAR)	8-7
8.3.2.2	SIM Configuration Register (SIMR)	8-8
8.3.2.3	Interrupt Control Register (ICR)	8-9
8.3.2.4	Interrupt Mask Register (IMR)	8-11
8.3.2.5	Interrupt Pending Register (IPR)	8-12
8.3.2.6	Reset Status Register (RSR)	8-13
8.3.2.7	System Protection Control Register (SYPCR)	8-13
8.3.2.8	Software Watchdog Interrupt Vector Register (SWIVR)	8-15
8.3.2.9	Software Watchdog Service Register (SWSR)	8-16
8.3.2.10	Pin Assignment Register (PAR)	8-16
8.4	Bus Arbitration Control	8-18
8.4.1	Bus Master Arbitration Control (MARB)	8-18

Section 9 Chip-Select Module

9.1	Introduction	9-1
9.1.1	Features	9-1
9.2	Chip Select Module I/O	9-1
9.2.1	Control Signals	9-1
9.2.1.1	Chip Select (CS[7:0])	9-1
9.2.1.2	Write Enable (WE[3:0])	9-1
9.2.1.3	Address Bus	9-3
9.2.1.4	Data Bus	9-4
9.2.1.5	Transfer acknowledge (TA)	9-4
9.3	Chip Select Operation	9-4
9.3.1	Chip Select Bank Definition	9-5
9.3.1.1	Base Address and Address masking	9-5
9.3.1.2	Access Permissions	9-6
9.3.1.3	Control Features	9-6
9.3.2	Global Chip Select Operation	9-8
9.3.3	General Chip Select Operation	9-8

TABLE OF CONTENTS (Continued)

Paragraph Number	Title	Page Number
9.3.3.1	Nonburst Transfer with no Address Setup or Hold	9-9
9.3.3.2	Nonburst Transfer With Address Setup	9-10
9.3.3.3	Nonburst Transfer With Address Setup and Hold	9-11
9.3.3.4	Burst Transfer and Chip Selects	9-13
9.3.3.5	Burst Transfer With Address Setup	9-15
9.3.3.6	Burst Transfer With Address Setup and Hold	9-17
9.3.4	External Master Chip Select Operation	9-20
9.3.4.1	External Master Nonburst Transfer	9-20
9.3.4.2	External Master Burst Transfer	9-22
9.3.4.3	External Master Burst Transfer with Setup and Hold ...	9-24
9.4	Programming Model	9-26
9.4.1	Chip Select Registers Memory Map	9-26

TABLE OF CONTENTS (Continued)

Paragraph Number	Title	Page Number
11.3.1	Reset Operation	11-4
11.3.1.1	Master Reset	11-5
11.3.1.2	Normal Reset	11-5
11.3.2	Definition of DRAM Banks	11-5
11.3.2.1	Base Address and Address Masking	11-5
11.3.2.2	Access Permissions	11-7
11.3.2.3	Timing	11-8
11.3.2.4	Page Mode	11-8
11.3.2.5	Port Size/Page Size	11-8
11.3.2.6	Address Multiplexing	11-8
11.3.3	Normal Mode Operation	11-15
11.3.3.1	Nonburst Transfer In Normal Mode	11-16
11.3.3.2	Burst Transfer In Normal Mode	11-18
11.3.4	Fast Page Mode Operation	11-21
11.3.4.1	Burst Transfer In Fast Page Mode	11-21
11.3.4.2	Page Hit Read Transfer In Fast Page Mode	11-23
11.3.4.3	Page-Hit Write Transfer in Fast Page Mode	11-25
11.3.4.4	Page Miss Transfer in Fast Page Mode	11-27
11.3.4.5	Bus Arbitration	11-30
11.3.5	Burst Page-Mode Operation	11-32
11.3.6	Extended Data-Out (EDO) DRAM Operation	11-35
11.3.7	Refresh Operation	11-38
11.3.8	External Master Use of the DRAM Controller	11-40
11.3.8.1	External Master Nonburst Transfer in Normal Mode ..	11-41
11.3.8.2	External Master Burst Transfer in Normal Mode	11-44
11.3.8.3	External Master Burst Transfer in Burst Page Mode ..	11-47
11.3.8.4	Limitations	11-50
11.4	Programming Model	11-50
11.4.1	DRAM Controller Registers Memory Map	11-50
11.4.2	DRAM Controller Registers	11-51
11.4.2.1	DRAM Controller Refresh Register (DCRR)	11-51
11.4.2.2	DRAM Controller Timing Register (DCTR)	11-52
11.4.2.3	DRAM Controller Address Reg. (DCAR0 - DCAR1) ...	11-58
11.4.2.4	DRAM Controller Mask Reg. (DCMR0 - DCMR1)	11-59
11.4.2.5	DRAM Controller Control Reg. (DCCR0 - DCCR1)	11-60
11.5	DRAM Initialization Example	11-61

Section 12 UART Modules

12.1	Module Overview	12-2
12.1.1	Serial Communication Channel	12-2

TABLE OF CONTENTS (Continued)

Paragraph Number	Title	Page Number
12.1.2	Baud-Rate Generator/Timer	12-3
12.1.3	Interrupt Control Logic	12-3
12.2	UART Module Signal Definitions	12-3
12.2.1	Transmitter Serial Data Output (TxD)	12-3
12.2.2	Receiver Serial Data Input (RxD)	12-4
12.2.3	Request-To-Send (RTS)	12-4
12.2.4	Clear-To-Send (CTS)	12-4
12.3	Operation	12-5
12.3.1	Baud-Rate Generator/Timer	12-5
12.3.2	Transmitter and Receiver Operating Modes	12-6
12.3.2.1	Transmitter	12-6
12.3.2.2	Receiver	12-9
12.3.2.3	FIFO Stack	12-11
12.3.3	Looping Modes	12-12
12.3.3.1	Automatic Echo Mode	12-12
12.3.3.2	Local Loopback Mode	12-12
12.3.3.3	Remote Loopback Mode	12-12
12.3.4	Multidrop Mode	12-14
12.3.5	Bus Operation	12-16
12.3.5.1	Read Cycles	12-16
12.3.5.2	Write Cycles	12-16
12.3.5.3	Interrupt Acknowledge Cycles	12-16
12.4	Register Description and Programming	12-16
12.4.1	Register Description	12-16
12.4.1.1	Mode Register 1 (UMR1)	12-17
12.4.1.2	Mode Register 2 (UMR2)	12-19
12.4.1.3	Status Register (USR)	12-21
12.4.1.4	Clock-Select Register (UCSR)	12-24
12.4.1.5	Command Register (UCR)	12-24
12.4.1.6	Receiver Buffer (URB)	12-27
12.4.1.7	Transmitter Buffer (UTB)	12-28
12.4.1.8	Input Port Change Register (UIPCR)	12-28
12.4.1.9	Auxiliary Control Register (UACR)	12-29
12.4.1.10	Interrupt Status Register (UISR)	12-29
12.4.1.11	Interrupt Mask Register (UIMR)	12-30
12.4.1.12	Timer Upper Preload Register 1 (UBG1)	12-31
12.4.1.13	Timer Upper Preload Register 2 (UBG2)	12-31
12.4.1.14	Interrupt Vector Register (UIVR)	12-31
12.4.2	Programming	12-33
12.4.2.1	UART Module Initialization	12-33
12.4.2.2	I/O Driver Example	12-33
12.4.2.3	Interrupt Handling	12-33

TABLE OF CONTENTS (Continued)

Paragraph Number	Title	Page Number
12.5	UART Module Initialization Sequence	12-34

Section 13 M-Bus Module

13.1	Overview	13-1
13.2	Interface Features	13-1
13.3	M-Bus System Configuration	13-2
13.4	M-Bus Protocol	13-3
13.4.1	START Signal	13-3
13.4.2	Slave Address Transmission	13-3
13.4.3	Data Transfer	13-4
13.4.4	Repeated START Signal	13-4
13.4.5	STOP Signal	13-4
13.4.6	Arbitration Procedure	13-4
13.4.7	Clock Synchronization	13-5
13.4.8	Handshaking	13-5
13.4.9	Clock Stretching	13-5
13.5	Programming Model	13-6
13.5.1	M-Bus Address Register (MADR)	13-6
13.5.2	M-Bus Frequency Divider Register (MFDR)	13-6
13.5.3	M-Bus Control Register (MBCR)	13-8
13.5.4	M-Bus Status Register (MBSR)	13-9
13.5.5	M-Bus Data I/O Register (MBDR)	13-11
13.6	M-Bus Programming Examples	13-11
13.6.1	Initialization Sequence	13-11
13.6.2	Generation of START	13-11
13.6.3	Post-Transfer Software Response	13-12
13.6.4	Generation of STOP	13-13
13.6.5	Generation of Repeated START	13-14
13.6.6	Slave Mode	13-14
13.6.7	Arbitration Lost	13-14

Section 14 Timer Module

14.1	Overview of the Timer Module	14-1
14.2	Overview of Key Features	14-1
14.3	General-Purpose Timer Units	14-2
14.3.1	Selecting the Prescaler	14-3
14.3.2	Capture Mode	14-3
14.3.3	Configuring the Timer for Reference Compare	14-3

TABLE OF CONTENTS (Continued)

Paragraph Number	Title	Page Number
14.3.4	Configuring the Timer for Output Mode	14-3
14.4	Programming Model	14-3
14.4.1	Understanding the General-Purpose Timer Registers	14-3
14.4.1.1	Timer Mode Register (TMR)	14-4
14.4.1.2	Timer Reference Register (TRR)	14-5
14.4.1.3	Timer Capture Register (TCR)	14-5
14.4.1.4	Timer Counter (TCN)	14-5
14.4.1.5	Timer Event Register (TER)	14-6

**Section 15
Debug Support**

15.1	Real-Time Trace	15-1
15.2	Background Debug Mode (BDM)	15-4
15.2.1	CPU Halt	15-4
15.2.2	BDM Serial Interface	15-6
15.2.3	BDM Command Set	15-7
15.2.3.1	BDM Command Set Summary	15-8
15.2.3.2	ColdFire BDM Commands	15-9
15.2.3.3	Command Sequence Diagram	15-10
15.2.3.4	Command Set Descriptions	15-11
15.3	Real-Time Debug Support	15-26
15.3.1	Theory of Operation	15-26
15.3.1.1	Emulator Mode	15-27
15.3.1.2	Debug Module Hardware	15-28
15.3.2	Concurrent BDM and Processor Operation	15-28
15.3.3	Programming Model	15-29
15.3.3.1	Address Breakpoint Registers (ABLR, ABHR)	15-30
15.3.3.2	Address Attribute Breakpoint Register (AATR)	15-30
15.3.3.3	Program Counter Breakpoint Register (PBR, PBMR)	15-32
15.3.3.4	Data Breakpoint Register (DBR, DBMR)	15-32
15.3.3.5	Trigger Definition Register (TDR)	15-33
15.3.3.6	Configuration/Status Register (CSR)	15-35
15.4	Motorola Recommended BDM Pinout	15-38
15.4.1	Differences Between the ColdFire BDM and CPU32 BDM	15-38

**Section 16
IEEE 1149.1 Test Access Port/JTAG**

16.1	Overview	16-2
16.2	JTAG Pin Descriptions	16-2
16.3	JTAG Register Descriptions	16-3

TABLE OF CONTENTS (Continued)

Paragraph Number	Title	Page Number
16.3.1	JTAG Instruction Shift Register	16-3
16.3.1.1	EXTEST Instruction	16-3
16.3.1.2	IDCODE	16-4
16.3.1.3	SAMPLE/PRELOAD Instruction	16-4
16.3.1.4	HIGHZ Instruction	16-4
16.3.1.5	CLAMP Instruction	16-5
16.3.1.6	BYPASS Instruction	16-5
16.3.2	IDcode Register	16-5
16.3.3	JTAG Boundary-Scan Register	16-6
16.3.4	JTAG Bypass Register	16-6
16.4	TAP Controller	16-6
16.5	Restrictions	16-7
16.6	Disabling the IEEE 1149.1 Standard Operation	16-8
16.7	Motorola MCF5206e BSDL Description	16-9
16.8	Obtaining the IEEE 1149.1 Standard	16-9

**Section 17
Electrical Characteristics**

17.1	Maximum Ratings.....	17-1
17.1.1	Supply, Input Voltage and Storage Temperature	17-1
17.1.2	Operating Temperature	17-2
17.1.3	Thermal Resistance	17-2
17.1.4	Output Loading	17-2
17.2	DC Electrical Specifications	17-3
17.3	AC Electrical Specifications	17-4
17.3.1	Clock Input Timing Specifications	17-4
17.3.2	Clock Input Timing Diagram	17-4
17.3.3	Processor Bus Input Timing Specifications	17-5
17.3.4	Input Timing Waveform Diagram	17-6
17.3.5	Processor Bus Output Timing Specifications	17-7
17.3.6	Output Timing Waveform Diagram	17-8
17.3.7	Processor Bus Timing Diagrams	17-9
17.3.8	Timer Module AC Timing Specifications	17-15
17.3.9	Timer Module Timing Diagram	17-15
17.3.10	UART Module AC Timing Specifications	17-16
17.3.11	UART Module Timing Diagram	17-16
17.3.12	M-Bus Module AC Timing Specifications	17-17
17.3.12.1	Input Timing Specifications Between SCL and SDA ...	17-17
17.3.12.2	Output Timing Specifications Between SCL and SDA	17-18
17.3.12.3	Timing Specifications Between CLK and SCL, SDA ...	17-18
17.3.13	M-Bus Module Timing Diagram	17-19

TABLE OF CONTENTS (Continued)

Paragraph Number	Title	Page Number
17.3.14	General-Purpose I/O Port AC Timing Specifications	17-20
17.3.15	General-Purpose I/O Port Timing Diagram	17-20
17.3.16	DMA Controller AC Timing Specifications	17-21
17.3.17	DMA Controller Timing Diagram	17-21
17.3.18	IEEE 1149.1 (JTAG) AC Timing Specifications	17-21
17.3.19	IEEE 1149.1 (JTAG) Timing Diagram	17-22

**Section 18
Mechanical Data**

18.1	Package Diagram & Pinout	18-2
18.1.1	Package/Frequency Availability	18-2
18.2	Documentation	18-3
18.3	Development Tools	18-3

**Appendix A
MCF5206e Memory Map Summary**

**Appendix B
Porting From M68000 Family Devices**

B.1	C-Compilers and Host Software	B-i
B.2	Target Software Port	B-i
B.3	Initialization Code	B-ii
B.4	Exception Handlers	B-ii
B.5	Supervisor Registers	B-iii

LIST OF ILLUSTRATIONS

Figure Number	Title	Page Number
1-1.	MCF5206e Block Diagram.....	1-4
1-2.	Programming Model.....	1-8
3-1.	ColdFire Processor Core Pipelines.....	3-1
3-2.	User Programming Model.....	3-3
3-3.	MAC Unit User Programming Model.....	3-4
3-4.	Supervisor Programming Model.....	3-4
3-5.	Exception Stack Frame Form.....	3-7
4-1.	Instruction Cache Block Diagram.....	4-2
6-1.	Signal Relationships to CLK.....	6-6
6-2.	Internal Operand Representation.....	6-8
6-3.	MCF5206e Interface to Various Port Sizes.....	6-8
6-4.	Byte-, Word-, and Longword-Read Transfer Flowchart.....	6-11
6-5.	Longword-Read Transfer From a 32 bit Port (No Wait States).....	6-12
6-6.	Byte-, Word-, and Longword-Write Transfer Flowchart.....	6-14
6-7.	Word-Write Transfer to a 16 bit Port (No Wait States).....	6-15
6-8.	Bursting Word-, Longword-, and Line-Read Transfer Flowchart.....	6-17
6-9.	Bursting Word-Read From an 8 bit Port (No Wait States).....	6-18
6-10.	Word-, Longword-, and Line-Write Transfer Flowchart.....	6-20
6-11.	Line-Write Transfer to a 32 bit Port (No Wait States).....	6-21
6-12.	Burst-Inhibited Word-, Longword-, and Line-Read Transfer Flowchart.....	6-24
6-13.	Burst-Inhibited Longword Read From an 8 bit Port (No Wait States).....	6-25
6-14.	Burst-Inhibited Byte-, Word-, and Longword-Write Transfer Flowchart.....	6-27
6-15.	Burst-Inhibited Longword-Write Transfer to a 16 bit Port (No Wait States).....	6-28
6-16.	Byte-, Word-, and Longword-Read Transfer Flowchart.....	6-30
6-17.	Byte-Read Transfer from an 8-Bit Port Using Async. Termination.....	6-31
6-18.	Byte-, Word-, and Longword-Write Transfer Flowchart.....	6-32
6-19.	Byte-Write Transfer to a 32-Bit Port Using Async. Termination.....	6-33
6-20.	Bursting Word-, Longword-, and Line-Read Transfer Flowchart.....	6-35
6-21.	Bursting Longword-Read from 16 bit Port.....	6-36
6-22.	Word-, Longword-, and Line-Write Transfer Flowchart.....	6-38
6-23.	Bursting Line-Write from 32 bit Port Using Async. Termination.....	6-39
6-24.	Burst-Inhibited Word-, Longword-, and Line-Read Transfer Flowchart.....	6-42

LIST OF ILLUSTRATIONS (Continued)

Figure Number	Title	Page Number
6-25.	Burst-Inhibited Word Read from 8 bit Port Using Async. Termination	6-43
6-26.	Burst-Inhibited Word-, Longword-, and Line-Write Transfer Flowchart	6-45
6-27.	Burst-Inhibited Longword-Write Transfer to 16 bit Port	6-46
6-28.	Example of a Misaligned Longword Transfer	6-48
6-29.	Example of a Misaligned Word Transfer	6-48
6-30.	Interrupt Acknowledge Cycle Flowchart.....	6-50
6-31.	Interrupt Acknowledge Bus Cycle Timing (No Wait States).....	6-51
6-32.	Bursting Longword-Read Access from 16 bit Port	6-53
6-33.	MCF5206e Two-Wire Mode Bus Arbitration Interface	6-55
6-34.	Two-Wire Implicit and Explicit Bus Ownership.....	6-57
6-35.	Two-Wire Bus Arbitration with Bus Lock Negated	6-58
6-36.	Two-Wire Bus Arbitration with Bus Lock Asserted.....	6-59
6-37.	MCF5206e Two-Wire Bus Arbitration Protocol State Diagram	6-60
6-38.	Three-Wire Implicit and Explicit Bus Ownership.....	6-63
6-39.	Three-Wire Bus Arbitration with Bus Lock Bit Asserted.....	6-64
6-40.	MCF5206e Bus Arbitration Protocol State Diagram	6-65
6-41.	Alternate Master Read Transfer using MCF5206e-Generated Transfer Acknowledge Flowchart.....	6-70
6-42.	Alternate Master Read Transfer.....	6-71
6-43.	Alternate Master Write Transfer.....	6-72
6-44.	Alternate Master Write Transfer Using Transfer-Acknowledge Timing	6-73
6-45.	Alternate Master Bursting Read Transfer Flowchart	6-75
6-46.	Alternate Master Bursting Longword Read Transfer to an 8 bit Port	6-76
6-47.	Alternate Master Bursting Write Transfer Flowchart.....	6-79
6-48.	Alternate Master Bursting Longword Write Transfer to a 16 bit Port	6-80
6-49.	Master Reset Timing.....	6-82
6-50.	Normal Reset Timing	6-83
6-51.	Software Watchdog Timer Reset Timing	6-84
7-1.	DMA Signal Diagram	7-2
7-2.	Single-Address Transfers	7-5
7-3.	Dual-Address Transfer.....	7-5
7-4.	DMA Controller Module Register Model Per Channel	7-6
7-5.	External Request Timing - Cycle-Steal Mode, Single-Address Mode.....	7-15
7-6.	External Request Timing - Cycle-Steal Mode, Dual-Address Mode	7-16
9-1.	MCF5206e Interface to Various Port Sizes.....	9-4
9-2.	Longword Write Transfer from a 32 bit Port	9-9
9-3.	Word Write Transfer to a 16 bit Port	9-10
9-4.	Byte Write Transfer from an 8 bit Port	9-12
9-5.	Longword Burst Read Transfer from a 16 bit Port	9-14

LIST OF ILLUSTRATIONS (Continued)

Figure Number	Title	Page Number
9-6.	Longword Burst Read Transfer from a 16 bit Port	9-16
9-7.	Word Burst Read Transfer from an 8 bit Port.....	9-18
9-8.	Alternate Master Longword Read Transfer from a 32 bit Port	9-21
9-9.	Alternate Master Longword Read Transfer from a 16 bit Port	9-23
9-10.	Alternate Master Longword Read Transfer from a 16 bit Port	9-25
9-11.	Chip-Select and Write-Enable Assertion with ASET = 0 Timing	9-34
9-12.	Chip-Select and Write-Enable Assertion with ASET = 1 Timing	9-34
9-13.	Address Hold Timing with WRAH = 0	9-36
9-14.	Address Hold Timing with WRAH = 1	9-36
9-15.	Address Hold Timing with RDAH = 0	9-37
9-16.	Address Hold Timing with RDAH = 1	9-38
9-17.	Default Memory Address Hold Timing with WRAH = 0	9-41
9-18.	Default Memory Address Hold Timing with WRAH = 1	9-42
9-19.	Default Memory Address Hold Timing with RDAH = 0	9-43
9-20.	Default Memory Address Hold Timing with RDAH = 1	9-43
11-1.	MCF5206e Interface to Various Port Sizes.....	11-4
11-2.	Address Multiplexing For 8-bit DRAM With 512 Byte Page Size	11-9
11-3.	Connection Diagram for 4MByte DRAM with 8 bit Port and 1 KByte Page..	11-15
11-4.	Connection Diagram for 1MByte DRAM with 8 bit Port and 1 KByte Page..	11-15
11-5.	Byte Read Transfers in Normal Mode with 8 bit DRAM	11-17
11-6.	Longword Write Transfer in Normal Mode with 16 bit DRAM	11-19
11-7.	Word Write Transfer in Fast Page Mode with 8 Bit DRAM	11-22
11-8.	Longword Read Transfer Followed by a Page Hit Longword Read Transfer in Fast Page Mode with 32 bit DRAM.....	11-24
11-9.	Word Write Transfer Followed by a Page-Hit Word Write Transfer in Fast Page Mode with 16 bit DRAM	11-26
11-10.	Byte Read Transfer Followed by a Page-Miss Byte Read Transfer in Fast Page Mode with 8 bit DRAM	11-28
11-11.	Bus Arbitration in Fast Page Mode	11-31
11-12.	Longword Write Transfer Followed by a Word Read Transfer in Burst Page Mode with 16 bit DRAM	11-33
11-13.	Word Read Transfer Followed by a Page Miss Byte Read Transfer in Fast Page Mode with 8 bit EDO DRAM.....	11-36
11-14.	Alternate Master Byte Read Transfer Followed by Byte Write Transfer in Normal Mode with 16 bit DRAM	11-42
11-15.	Alt. Master Longword Write Transfer in Normal Mode with 16 bit DRAM	11-45
11-16.	Alt. Master Word Read Transfer in Burst Page Mode with 8 bit DRAM.....	11-48
11-17.	Normal Mode DRAM Transfer Timing.....	11-53
11-18.	Fast Page Mode or Burst Page Mode DRAM Transfer Timing	11-54
11-19.	Fast Page Mode or Burst Page Mode DRAM Transfer Timing	11-54

LIST OF ILLUSTRATIONS (Continued)

Figure Number	Title	Page Number
11-20.	Fast Page Mode Page Hit and Page Miss DRAM Transfer Timing	11-56
11-21.	Fast Page Mode or Burst Page Mode EDO DRAM Transfer Timing	11-57
11-22.	CAS Before RAS Refresh Cycle Timing	11-58
12-1.	UART Block Diagram.....	12-1
12-2.	External and Internal Interface Signals.....	12-4
12-3.	Baud-Rate Timer Generator Diagram.....	12-5
12-4.	Transmitter and Receiver Functional Diagram	12-7
12-5.	Transmitter Timing Diagram	12-8
12-6.	Receiver Timing Diagram	12-10
12-7.	Looping Modes Functional Diagram	12-13
12-8.	Multidrop Mode Timing Diagram.....	12-15
13-1.	M-Bus Module Block Diagram	13-2
13-2.	M-Bus Standard Communication Protocol.....	13-3
13-3.	Synchronized Clock SCL	13-5
13-4.	Flow-Chart of Typical M-Bus Interrupt Routine.....	13-16
14-1.	Timer Block Diagram Module Operation.....	14-2
15-1.	Processor/Debug Module Interface	15-1
15-2.	Pipeline Timing Example (Debug Output)	15-3
15-3.	BDM Serial Transfer	15-6
15-4.	BDM Signal Sampling.....	15-7
15-5.	Command Sequence Diagram.....	15-11
15-6.	Debug Programming Model.....	15-29
15-7.	26-Pin Berg Connector Arranged 2x13.....	15-38
15-8.	Serial Transfer Illustration.....	15-39
16-1.	JTAG Test Logic Block Diagram.....	16-2
16-2.	JTAG TAP Controller State Machine	16-7
16-3.	Disabling JTAG in JTAG Mode	16-8
16-4.	Disabling JTAG in Debug Mode.....	16-9
17-1.	Clock Input Timing	17-5
17-2.	Input Timing Waveform Requirements	17-7
17-3.	Output Timing Waveform	17-9

LIST OF ILLUSTRATIONS (Continued)

Figure Number	Title	Page Number
17-4.	Reset Configuration Timing.....	17-10
17-5.	Read and Write Timing	17-11
17-6.	Bus Arbitration Timing.....	17-12
17-7.	DRAM Signal Timing.....	17-13
17-8.	DRAM Refresh Cycle Timing	17-13
17-9.	DRAM Control By Alternate Master Timing.....	17-14
17-10.	Miscellaneous Signal Timing.....	17-15
17-11.	Timer Timing	17-16
17-12.	UART Timing.....	17-17
17-13.	M-Bus Timing.....	17-20
17-14.	General-Purpose I/O Port Timing.....	17-21
17-15.	DMA Timing	17-22
17-16.	IEEE 1149.1 (JTAG) Timing.....	17-23
18-1.	MCF5206e Package Diagram & Pinout	18-2

LIST OF ILLUSTRATIONS (Continued)

**Figure
Number**

Title

**Page
Number**

Freescale Semiconductor, Inc.

LIST OF TABLES

Table Number	Title	Page Number
1-1.	Specific Effective Addressing Modes	1-7
1-2.	MOVE Specific Effective Addressing Modes	1-7
1-3.	ColdFire MCF5206e Data Formats	1-9
1-4.	Instruction Set Summary	1-10
2-1.	MCF5206e Signal Index.....	2-2
2-2.	Address Bus.....	2-3
2-3.	Byte Write-Enable Signals	2-6
2-4.	Interrupt Levels for Encoded External Interrupts.....	2-7
2-5.	Boot CS[0] Automatic Acknowledge (AA) Enable	2-8
2-6.	Interrupt Request Encodings for CS[0]	2-8
2-7.	Data Transfer Size Encoding	2-9
2-8.	Bus Cycle Transfer Type Encoding.....	2-9
2-9.	ATM Encoding.....	2-9
2-10.	CAS Assertion.....	2-13
2-11.	Processor Status Encodings	2-16
2-12.	MCF5206e Signal Summary	2-19
3-1.	Exception Vector Assignments	3-7
3-2.	Format Field Encodings	3-8
3-3.	Fault Status Encodings	3-8
3-4.	Misaligned Operand References.....	3-12
3-5.	Move Byte and Word Execution Times	3-13
3-6.	Move Long Execution Times.....	3-13
3-7.	One-Operand Instruction Execution Times	3-14
3-8.	Two-Operand Instruction Execution Times.....	3-15
3-9.	Miscellaneous Instruction Execution Times	3-17
3-10.	General Branch Instruction Execution Times.....	3-18
3-11.	BRA, Bcc Instruction Execution Times.....	3-18
4-1.	Initial Fetch Offset vs. CLNF Bits	4-4
4-2.	Instruction Cache Operation as Defined by CACR[31,10]	4-5
4-3.	Memory Map of I-Cache Registers	4-6
4-4.	External Fetch Size Based on Miss Address and CLNF.....	4-8

LIST OF TABLES (Continued)

Figure Number	Title	Page Number
5-1.	Memory Map of SIM Registers	5-2
5-2.	Examples of Typical RAMBAR Settings	5-4
6-1.	SIZx Encoding.....	6-2
6-2.	Transfer Type Encoding.....	6-3
6-3.	ATM Encoding	6-3
6-4.	Chip Select, DRAM and Default Memory Address Decoding Priority	6-7
6-5.	SIZx Encoding for Burst- and Bursting-Inhibited Ports	6-9
6-6.	Address Offset Encoding	6-9
6-7.	Data Bus Requirement for Read Cycles	6-10
6-8.	Internal to External Data Bus Multiplexer - Write Cycle	6-13
6-9.	SIZx Encoding for Burst- and Bursting-Inhibited Ports	6-19
6-10.	MCF5206e Two-Wire Bus Arbitration Protocol Transition Conditions	6-59
6-11.	MCF5206e Two-Wire Arbitration Protocol State Diagram	6-60
6-12.	MCF5206e Three-Wire Bus Arbitration Protocol Transition Conditions.....	6-65
6-13.	MCF5206e Three-Wire Arbitration Protocol State Diagram.....	6-66
6-14.	Signal Source During Alternate Master Accesses	6-69
7-1.	DMA Signals	7-3
7-2.	DMA Controller Module Channel Offsets.....	7-6
7-3.	BWC Encoding	7-9
7-4.	SSIZE Encoding.....	7-10
7-5.	DSIZE Encoding	7-10
8-1.	Interrupt Levels for Encoded External Interrupts	8-4
8-2.	Memory Map of SIM Registers	8-7
8-3.	Interrupt Control Register Assignments	8-10
8-4.	Interrupt Mask Register Bit Assignments.....	8-11
8-5.	Interrupt Pending Register Bit Assignments	8-12
8-6.	SWT Timeout Period.....	8-15
8-7.	Bus Monitor Timeout Periods.....	8-15
8-8.	PAR3 - PAR0 Pin Assignment.....	8-17
8-9.	Arbitration Control Encodings (ARBCTRL).....	8-19

Freescale Semiconductor, Inc.

LIST OF TABLES (Continued)

Figure Number	Title	Page Number
9-1.	Data Bus Byte Write-Enable Signals.....	9-2
9-2.	Maximum Memory Bank Sizes.....	9-4
9-3.	Chip-Select, DRAM and Default Memory Address Decoding Priority.....	9-6
9-4.	Memory Map of Chip-Select Registers	9-27
9-5.	BA Field Comparisons for Alternate Master Transfers.....	9-29
9-6.	IRQ4 and IRQ1 Selection of CS[0] Port Size	9-32
9-7.	IRQ7 Selection of CS[0] Acknowledge Generation.....	9-32
9-8.	Port Size Encodings.....	9-39
10-1.	Memory Map of Parallel Port Registers	10-1
10-2.	Data Direction Register Bit Assignments	10-2
10-3.	Data Register Bit Assignments	10-3
11-1.	CAS Assertion.....	11-2
11-2.	Maximum DRAM Bank Sizes	11-3
11-3.	DRAM Bank Programming Example 1.....	11-6
11-4.	Chip-Select, DRAM and Default Memory Address Decoding Priority.....	11-7
11-5.	DRAM Bank Programming Example 2.....	11-8
11-6.	8-bit Port Size Address Multiplexing Configurations	11-11
11-7.	16-bit Port Size Address Multiplexing Configurations	11-12
11-8.	32-bit Port Size Address Multiplexing Configurations	11-13
11-9.	Bank Page Size Versus Actual DRAM Page Size	11-14
11-10.	Memory Map of DRAM Controller Registers.....	11-51
12-1.	UART Module Programming Model	12-17
12-2.	PMx and PT Control Bits.....	12-18
12-3.	B/Cx Control Bits.....	12-19
12-4.	CMx Control Bits	12-19
12-5.	SBx Control Bits	12-20
12-6.	RCSx Control Bits	12-24
12-7.	TCSx Control Bits.....	12-24
12-8.	MISCx Control Bits.....	12-25
12-9.	TCx Control Bits.....	12-26
12-10.	RCx Control Bits.....	12-27
13-1.	M-Bus Interface Programmer's Model	13-6
13-2.	MBUS Prescaler Values.....	13-7

LIST OF TABLES (Continued)

Figure Number	Title	Page Number
14-1.	Programming Model for Timers	14-3
15-1.	Processor PST Definition.....	15-2
15-2.	CPU-Generated Message Encoding.....	15-7
15-3.	BDM Command Summary	15-7
15-4.	BDM Size Field Encoding	15-8
15-5.	Control Register Map	15-23
15-6.	Definition of DRc Encoding - Read	15-25
15-7.	Definition of DRc Encoding - Write	15-26
15-8.	SIZE Encodings	15-29
15-9.	Transfer Type Encodings.....	15-29
15-10.	Transfer Modifier Encodings for Normal Transfers	15-30
15-11.	Transfer Modifier Encodings for Alternate Access Transfers.....	15-30
15-12.	Core Address, Access Size, and Operand Location.....	15-30
15-13.	DDATA, CSR[31:28] Breakpoint Response.....	15-36
15-14.	Shared BDM/Breakpoint Hardware.....	15-37
16-1.	JTAG Pin Descriptions.....	16-3
16-2.	JTAG Instructions	16-3
17-1.	Supply, Input Voltage and Storage Temperature	17-1
17-2.	Operating Temperature.....	17-1
17-3.	Thermal Resistance	17-2
17-4.	Output Loading	17-2
17-5.	DC Electrical Specifications	17-3
17-6.	I/O Driver Capability.....	17-4
17-7.	Clock Input Timing Specifications	17-5
17-8.	Processor Bus Input Timing Specifications.....	17-6
17-9.	Processor Bus Output Timing Specifications.....	17-8
17-10.	Timer Module AC Timing Specifications	17-16
17-11.	UART Module AC Timing Specifications	17-17
17-12.	INPUT Timing Specifications Between SCL and SDA.....	17-18
17-13.	Output Timing Specifications Between SCL and SDA.....	17-19
17-14.	Timing Specifications Between CLK and SCL, SDA.....	17-19
17-15.	General-Purpose I/O Port AC Timing Specifications	17-21
17-16.	IEEE 1149.1 (JTAG) AC Timing Specifications	17-22
18-1.	MCF5206e Package/Frequency Availability	18-3
18-2.	MCF5206e Documentation.....	18-3

LIST OF TABLES (Continued)

Figure Number	Title	Page Number
18-3.	Development Tools Providers.....	18-3
A-1.	MCF5206e User Programming Model	A-i

LIST OF TABLES (Continued)

**Figure
Number**

Title

**Page
Number**

Freescale Semiconductor, Inc.

SECTION 1 INTRODUCTION

1.1 BACKGROUND

The MCF5206e integrated microprocessor combines a Version 2 (V2) ColdFire® processor core with several peripheral functions such as a DRAM controller, timers, general-purpose I/O and serial interfaces, debug module, and system integration. Designed for embedded control applications, the V2 ColdFire core delivers enhanced performance while maintaining low system costs. To speed program execution, the large on-chip instruction cache and SRAM provide one-cycle access to critical code and data. The MCF5206e greatly reduces the time required for system design and implementation by packaging common system functions on chip and providing glueless interfaces to 8 bit, 16 bit, and 32 bit DRAM, SRAM, ROM, and I/O devices.

The MCF5206e is an enhanced version of the MCF5206 processor, with the same peripheral set, DMA, MAC, Hardware Divide, larger cache, and larger SRAM. It is pin compatible with the MCF5206, with the DMA pins muxed with Timer 0 pins. Available in 3.3V, with 5V-tolerant I/O, at speeds of 45 MHz and 54 MHz; higher performance at a lower price.

The revolutionary ColdFire microprocessor architecture gives cost-sensitive, high-volume markets new levels of price and performance. Based on the concept of variable-length RISC technology, ColdFire combines the architectural simplicity of conventional 32 bit RISC with a memory-saving, variable-length instruction set. In defining the ColdFire architecture for embedded processing applications, Motorola incorporated RISC architecture for peak performance and a simplified version of the variable-length instruction set found in the M68000 Family for code density and programmer familiarity.

By incorporating a variable-length instruction set architecture, embedded processor designers using ColdFire processors will enjoy significant system-level advantages over conventional 32-bit fixed-length RISC architectures. The denser binary code for ColdFire processors consumes less valuable memory than any 32-bit fixed-length instruction set RISC processor available. This improved code density means more efficient system memory use for a given application and requires slower, less costly memory to help achieve a target performance level.

The integrated peripheral functions provide high performance and flexibility. For starters, the DRAM controller supports as much as 512 Mbytes of DRAM. The MCF5206e supports both page-mode and extended-data-out DRAMs. Two channels of DMA allow for fast data transfer using a programmable burst mode independent of processor execution. The serial interfaces consist of two programmable full duplex UARTs and a separate I²C¹-compatible Motorola bus (M-Bus interface). The two 16-bit general-purpose multimode timers provide

separate input and output signals. For system protection, the processor includes a programmable 16-bit software watchdog timer and several bus monitors. In addition, common system functions such as chip selects, interrupt control, bus arbitration, and IEEE 1149.1 Test (JTAG) support are included.

A sophisticated debug interface supports both background-debug mode and real-time trace. This interface is common to all ColdFire processors and allows common emulator support across the entire ColdFire Family.

1.2 MCF5206E FEATURES

The primary features of the MCF5206e integrated processor include the following:

- Version 2 ColdFire Processor Core
 - Variable-length RISC
 - 32-bit data bus
 - 16 user-visible 32-bit registers
 - Supervisor / User modes for system protection
 - Vector base register to relocate exception vector table
 - Optimized for high-level language constructs
 - 50 MIPS at 54MHz
- Multiply/Accumulate Unit
 - Provides high-speed, complex arithmetic processing for simple signal processing applications
 - 1 clock issue with 3-stage execute pipeline
 - Supports both 16x16 multiplies and 32x32 multiplies with 32-bit accumulate
- 4 KByte Direct-Mapped Instruction Cache
 - Provides one-cycle access to critical code
- 8 KByte On-Chip SRAM
 - Provides one-cycle access to critical code and data
- Hardware Divide Module
 - Supported divide functions include:
 - 32/16, producing a 16-bit quotient and 16-bit remainder;
 - 32/32, producing a 32-bit quotient;
 - 32/32, producing a 32-bit remainder.
- DRAM Controller
 - Programmable refresh timer provides CAS-before-RAS refresh
 - Support for 2 separate memory banks
 - Support for page-mode DRAMs and extended-data-out (EDO) DRAMs
 - Allows external bus master access

1. I²C is a proprietary Philips interface bus.

- DMA Controller
 - Two fully programmable channels
 - Supports dual-address and single-address transfers, with 32-bit capability
 - Two address pointers per channel that can increment or remain constant
 - 16-bit transfer counter per channel
 - Operand packing and unpacking supported
 - Auto-alignment transfers supported for efficient block movement
 - Supports bursting and cycle steal
 - Provides two clock-cycle internal access
 - Three request mechanisms: Software via register bits; External $\overline{\text{DREQ}}$; UART interrupts.
- Two Universal Synchronous/Asynchronous Receiver/Transmitter (UART) Modules
 - Full duplex operation
 - Baud-rate generator
 - Modem control signals available ($\overline{\text{CTS}}$, $\overline{\text{RTS}}$)
 - Processor-interrupt capability
- Dual 16-Bit General-Purpose Multimode Timers
 - 8-bit prescaler
 - Timer input and output pins
 - 30 ns resolution with 33 MHz system clock
 - Processor-interrupt capability
- Motorola Bus (M-Bus) Module
 - Interchip bus interface for EEPROMs, LCD controllers, A/D converters, keypads
 - Compatible with industry-standard I²C Bus
 - Master or slave modes support multiple masters
 - Automatic interrupt generation with programmable level
- System Interface
 - Glueless bus interface to 8 bit, 16 bit, and 32 bit DRAM, SRAM, ROM, and I/O devices
 - 32-bit internal address bus with 28 bit external bus; chip select and DRAM
 - 8 programmable chip selects
 - Programmable wait states and port sizes
 - Allows external bus masters to access chip selects
 - System protection
 - 16-bit software watchdog timer with prescaler
 - Double bus fault monitor
 - Bus timeout monitor
 - Spurious interrupt monitor
 - Programmable interrupt controller
 - Low interrupt latency
 - 3 external interrupt inputs
 - Programmable interrupt priority and autovector generator
 - IEEE 1149.1 test (JTAG) support

- 8-bit general-purpose I/O interface
- System Debug Support
 - Real-time trace
 - Background debug interface
- Fully Static 3.3-Volt Operation
- Fully 5V tolerant pads on all I/O and address/data buses
- 160 Pin PQFP Package, pin compatible with MCF5206.
- Available at 45 MHz and 54 MHz.
- 3.3V with 5V-tolerant I/O.
- Extended temperature (-40/+85 Deg C) available.

1.3 FUNCTIONAL BLOCKS

Figure 1-1 is a block diagram of the MCF5206e processor. The paragraphs that follow

provide an overview of the integrated processor.

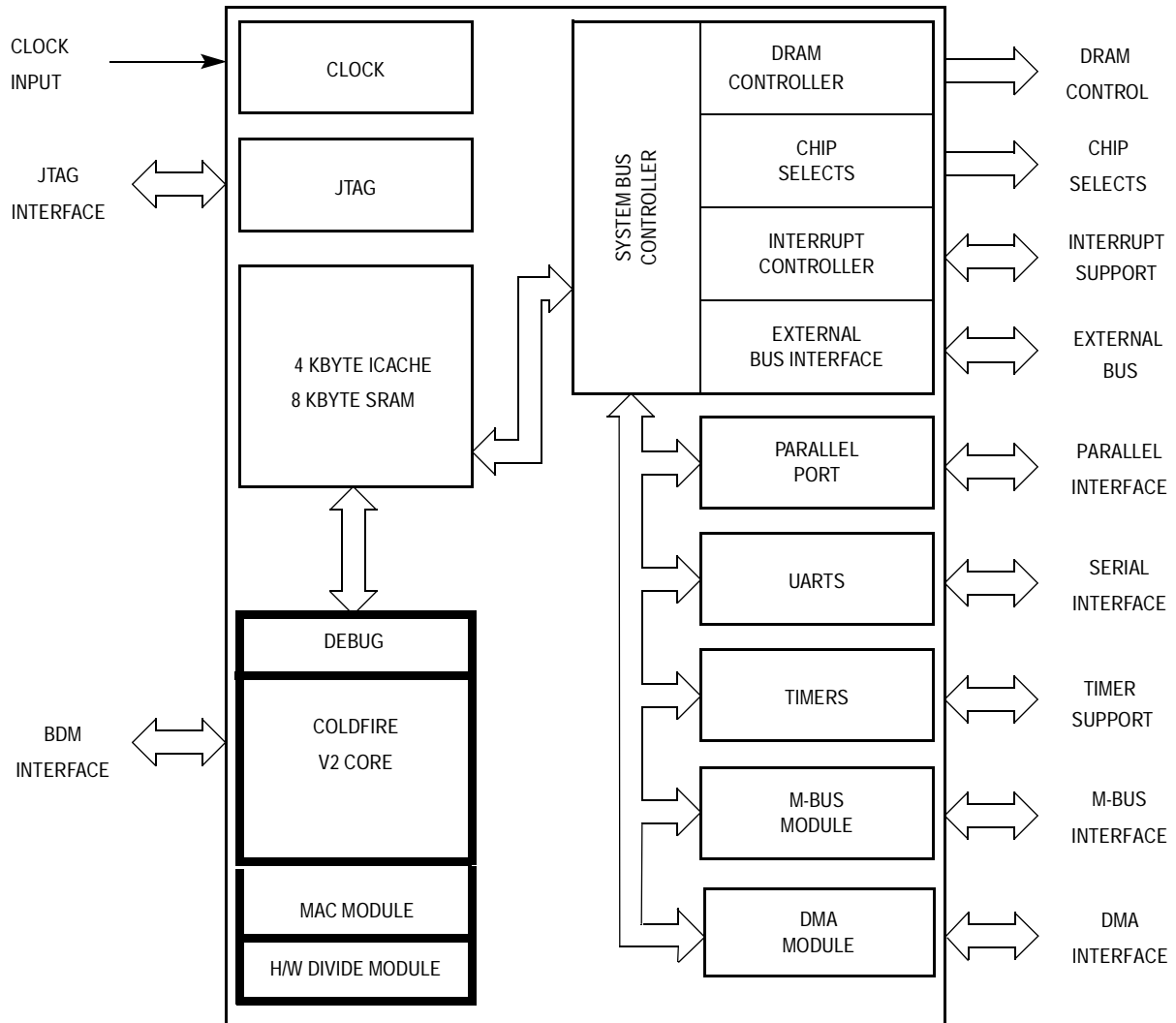

Figure 1-1. MCF5206e Block Diagram

1.3.1 ColdFire Processor Core

The ColdFire processor core consists of two independent, decoupled pipeline structures to maximize performance while minimizing core size. The instruction fetch pipeline (IFP) is a two-stage pipeline for prefetching instructions. The prefetched instruction stream is then gated into the two-stage operand execution pipeline (OEP), which decodes the instruction, fetches the required operands and then executes the required function. Because the IFP and OEP pipelines are decoupled by an instruction buffer that serves as a FIFO queue, the IFP can prefetch instructions in advance of their actual use by the OEP, thereby minimizing time stalled waiting for instructions. The OEP is implemented in a two-stage pipeline featuring a traditional RISC datapath with a dual-read-ported register file feeding an arithmetic/logic unit. The MCF5206e also includes MAC and hardware divide instructions which enhance the mathematical performance.

1.3.1.1 PROCESSOR STATES. The processor is always in one of four states: normal processing, exception processing, stopped, or halted. It is in the normal processing state when executing instructions, fetching instructions and operands, and storing instruction results.

Exception processing is the transition from program processing to system, interrupt, and exception handling. Exception processing includes fetching the exception vector, stacking operations, and refilling the instruction fetch pipe after an exception. The processor enters exception processing when an exceptional internal condition arises, such as tracing an instruction, an instruction resulting in a trap, or executing specific instructions. External conditions, such as interrupts and access errors, also cause exceptions. Exception processing ends when the first instruction of the exception handler enters the operand execution pipeline.

Stopped mode is a reduced power operation mode that causes the processor to remain quiescent until either a reset or nonmasked interrupt occurs. The STOP instruction is used to enter this operation mode.

The processor halts when it receives an access error or generates an address error while in the exception processing state. For example, if during exception processing of one access error another access error occurs, the MCF5206e processor cannot complete the transition to normal processing nor can it save the internal machine state. The processor assumes that the system is not operational and halts. Only an external reset can restart a halted processor. When the processor executes a STOP instruction, it is in a special type of normal processing state, e.g., one without bus cycles. The processor stops but it does not halt.

The processor can also halt in a restart mode because of background debug mode events.

1.3.1.2 PROGRAMMING MODEL. The ColdFire programming model is separated into two privilege modes: supervisor and user. The S bit in the status register (SR) indicates the current privilege mode. The processor identifies a logical address by accessing either the supervisor or user address space, which differentiates between supervisor and user modes.

Programs access registers based on the indicated mode. User programs can access only registers specific to the user mode. System software executing in the supervisor mode can access all registers using the control registers to perform supervisory functions. User programs are thus restricted from accessing privileged information. The operating system performs management and service tasks for user programs by coordinating their activities. This difference allows the supervisor mode to protect system resources from uncontrolled accesses.

Most instructions execute in either mode but some instructions that have important system effects are privileged and can execute only in the supervisor mode. For instance, user programs cannot execute the STOP instructions. To prevent a program executing in user mode from entering the supervisor mode, instructions that can alter the S bit in the SR are privileged. The TRAP instructions provide controlled access to operating system services for user programs.

Table 1-1. EFFECTIVE ADDRESSING MODES AND CATEGORIES

ADDRESSING MODES	SYNTAX	MODE FIELD	REG. FIELD	CATEGORY			
				DATA	MEMORY	CONTROL	ALTERABLE
Register Direct Data Address	Dn An	000 001	reg. no. reg. no.	X —	— —	— —	X X
Register Indirect Address	(An)	010	reg. no.	X	X	X	X
Address with Postincrement	(An)+	011	reg. no.	X	X	—	X
Address with Predecrement	-(An)	100	reg. no.	X	X	—	X
Address with Displacement	(d ₁₆ , An)	101	reg. no.	X	X	X	X
Address Register Indirect with Index 8-Bit Displacement	(d ₈ , An, Xi)	110	reg. no.	X	X	X	X
Program Counter Indirect with Displacement	(d ₁₆ , PC)	111	010	X	X	X	—
Program Counter Indirect with Index 8-Bit Displacement	(d ₈ , PC, Xi)	111	011	X	X	X	—
Absolute Data Addressing Short	(xxx).W	111	000	X	X	X	—
Long	(xxx).L	111	001	X	X	X	—
Immediate	#<xxx>	111	100	X	X	—	—

The processor employs the user mode and the user programming model when it is in normal processing. During exception processing, the processor changes from user to supervisor mode. Exception processing saves the current SR value on the stack and then sets the S bit, forcing the processor into the supervisor mode. To return to the user mode, a system routine must execute a MOVE to SR, or an RTE, which operate in the supervisor mode, modifying the S bit of the SR. After these instructions execute, the instruction fetch pipeline flushes and is refilled from the appropriate address space.

The registers depicted in the programming model (see Figure 1-2) provide operand storage and control for the ColdFire processor core. The registers are also partitioned into user and supervisor privilege modes. The user programming model consists of 16 general-purpose, 32 bit registers and two control registers. The supervisor model consists of five more registers that can be accessed only by code running in supervisor mode.

Only system programmers can use the supervisor programming model to implement operating system functions and I/O control. This supervisor/user distinction allows for the coding of application software that will run without modification on any ColdFire Family processor. The supervisor programming model contains the control features that system designers would not want user code to erroneously access as this might effect normal system operation. Furthermore, the supervisor programming model may need to change slightly from ColdFire generation to generation to add features or improve performance as the architecture evolves.

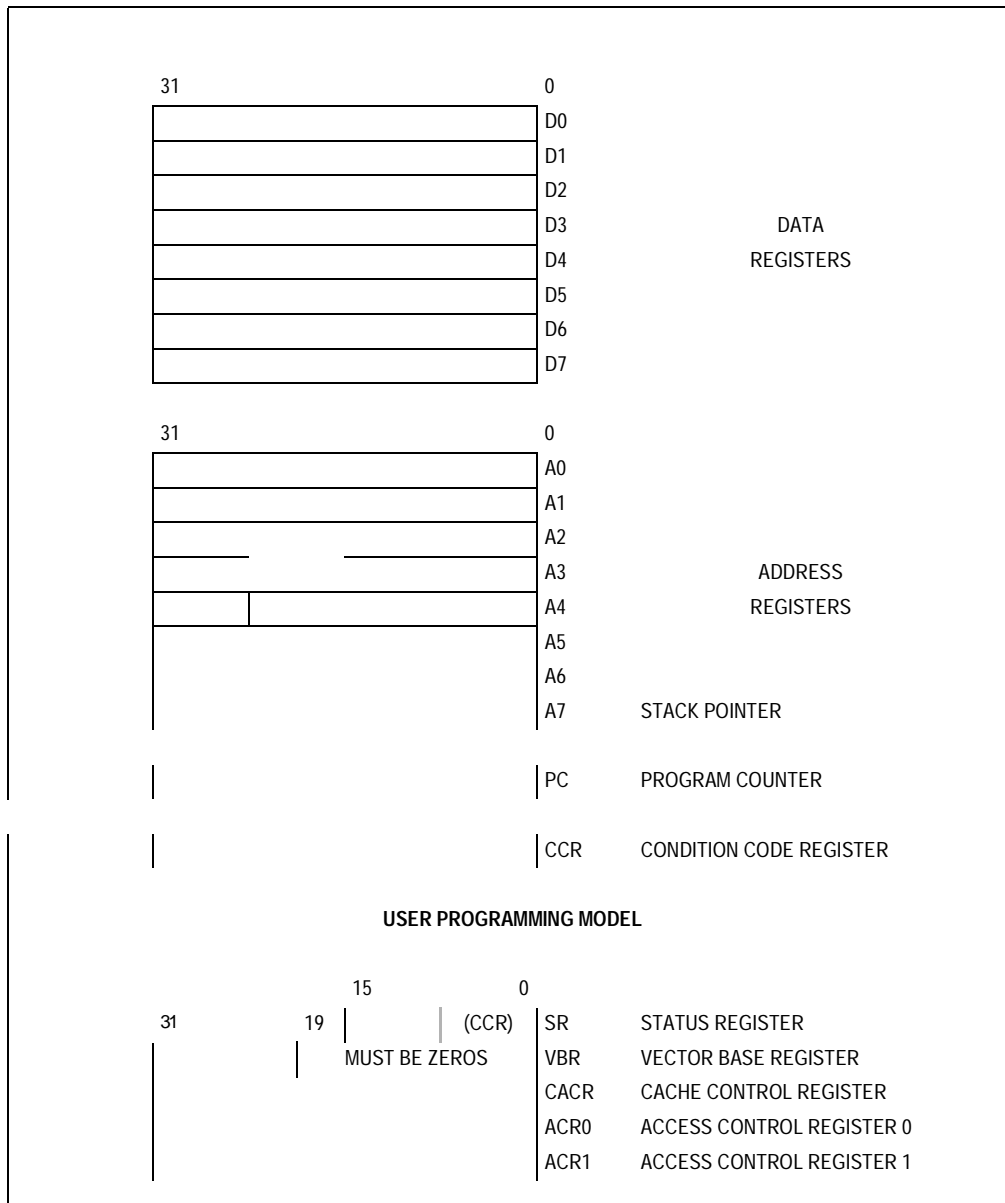

Figure 1-2. Programming Model

The user programming model includes eight data registers, seven address registers, and a stack pointer register. The address registers and stack pointer can be used as base address registers or software stack pointers, and any of the 16 registers can be used as index registers. Two control registers are available in the user mode: the program counter (PC), which contains the address of the instruction that the MCF5206e device is executing, and the lower byte of the SR, which is accessible as the Condition Code Register (CCR). The CCR contains the condition codes that reflect the results of a previous operation and can be used for conditional instruction execution in a program.

The supervisor programming model includes the upper byte of the SR, which contains operation control information. The Vector Base Register (VBR) contains the upper 12 bits of the base address of the exception vector table, which is used in exception processing. The lower 20 bits of the VBR are forced to zero, allowing the vector table to reside on any 1 Mbyte memory boundary.

The Cache Control Register (CACR) controls enabling of the on-chip cache. Two access control registers (ACR1, ACR0) allow portions of the address space to be mapped as noncacheable. See subsections 4.3 and 4.4 for details on these registers.

1.3.1.3 MAC REGISTERS SUMMARY. The processor performs all arithmetic using 2's complement, but operands can be signed or unsigned. Registers, memory, or instructions themselves can contain operands. The operand size for each instruction is either explicitly encoded in the instruction or implicitly defined by the instruction operation. Table 1-3 summarizes the MCF5206e data formats.

Table 1-2. MCF5206e Data Formats

OPERAND DATA FORMAT	SIZE
Bit	1 bit
Byte	8 bits
Word	16 bits
Longword	32 bits

1.2.1.4 ADDRESSING CAPABILITIES SUMMARY. The MCF5206e processor supports seven addressing modes. The register indirect addressing modes support postincrement, predecrement, offset, and indexing, which are particularly useful for handling data structures common to sophisticated embedded applications and high-level languages. The program counter indirect mode also has indexing and offset capabilities. This addressing mode is typically required to support position-independent software. Besides these addressing modes, the MCF5206e processor provides index scaling features.

An instruction's addressing mode can specify the value of an operand or a register containing the operand. It can also specify how to derive the effective address of an operand in memory. Each addressing mode has an assembler syntax. Some instructions imply the addressing mode for an operand. These instructions include the appropriate fields for operands that use only one addressing mode. Table 1-1 summarizes the specific effective addressing modes of ColdFire processors. Table 1-2 summarizes the MOVE specific effective addressing modes.

1.2.1.5 INSTRUCTION SET OVERVIEW. The ColdFire instruction set supports high-level languages and is optimized for those instructions embedded code most commonly executes. Table 1-3 lists the notational conventions used throughout this manual, unless otherwise specified. Table 1-4 provides an alphabetized listing of the ColdFire instruction set opcode, operation, and syntax. The left operand in the syntax is always the source operand and the right operand is the destination operand. This instruction set is a simplified version of the M68K instruction set. The removed instructions include BCD, bit field, logical rotate, decrement and branch, and integer multiply with a 64-bit result. In addition, nine new MAC instructions have been added.

Table 1-3. Notational Conventions

OPCODE WILDCARDS	
cc	Logical Condition (example: NE for not equal)
REGISTER OPERANDS	
An	Any Address Register n (example: A3 is address register 3)
Ay,Ax	Source and destination address registers, respectively
Dn	Any Data Register n (example: D5 is data register 5)
Dy,Dx	Source and destination data registers, respectively
Rn	Any Address or Data Register
Ry,Rx	Any source and destination registers, respectively
Rw	Any second destination register
Rc	Any Control Register (example: VBR is the vector base register)
REGISTER/PORT NAMES	
ACC	MAC Accumulator
DDATA	Debug Data Port
CCR	Condition Code Register (lower byte of status register)
MACSR	MAC Status Register
MASK	Mask Register
PC	Program Counter
PST	Processor Status Port
SR	Status Register
MISCELLANEOUS OPERANDS	
#<data>	Immediate data following the instruction word(s)
<ea>	Effective Address
<ea>y,<ea>x	Source and Destination Effective Addresses, respectively
<label>	Assembly Program Label
<list>	List of registers (example: D3–D0)
<size>	Operand data size: Byte (B), Word (W), Longword (L)
OPERATIONS	
+	Arithmetic addition or postincrement indicator
–	Arithmetic subtraction or predecrement indicator
x	Arithmetic multiplication
/	Arithmetic division
~	Invert; operand is logically complemented
&	Logical AND
	Logical OR
^	Logical exclusive OR
<<	Shift left (example: D0 << 3 is shift D0 left 3 bits)
>>	Shift right (example: D0 >> 3 is shift D0 right 3 bits)
→	Source operand is moved to destination operand
←→	Two operands are exchanged
sign-extended	All bits of the upper portion are made equal to the high-order bit of the lower portion
If <condition> then <operations> else <operations>	Test the condition. If true, the operations after ‘then’ are performed. If the condition is false and the optional ‘else’ clause is present, the operations after ‘else’ are performed. If the condition is false and else is omitted, the instruction performs no operation. Refer to the Bcc instruction description as an example.

SUBFIELDS AND QUALIFIERS	
{}	Optional Operation
()	Identifies an indirect address
d_n	Displacement Value, n bits Wide (example: d_{16} is a 16 bit displacement)
Address	Calculated Effective Address (pointer)
Bit	Bit Selection (example: Bit 3 of D0)
LSB	Least Significant Bit (example: LSB of D0)
LSW	Least Significant Word
MSB	Most Significant Bit
MSW	Most Significant Word
CONDITION CODE REGISTER BIT NAMES	
P	Branch Prediction Bit in CCR
C	Carry Bit in CCR
N	Negative Bit in CCR
V	Overflow Bit in CCR
X	Extend Bit in CCR
Z	Zero Bit in CCR

Table 1-4. Instruction Set Summary

INSTRUCTION	OPERAND SYNTAX	OPERAND SIZE	OPERATION
ADD	Dy,<ea>x <ea>y,Dx	32 32	Source + Destination → Destination
ADDA	<ea>y,Ax	32	Source + Destination → Destination
ADDI	#<data>,Dx	32	Immediate Data + Destination → Destination
ADDQ	#<data>,<ea>x	32	Immediate Data + Destination → Destination
ADDX	Dy,Dx	32	Source + Destination + X → Destination
AND	Dy,<ea>x <ea>y,Dx	32 32	Source & Destination → Destination
ANDI	#<data>,Dx	32	Immediate Data & Destination → Destination
ASL	Dy,Dx #<data>,Dx	32 32	X/C ← (Dx << Dy) ← 0 X/C ← (Dx << #<data>) ← 0
ASR	Dy,Dx <data>,Dx	32 32	MSB → (Dx >> Dy) → X/C MSB → (Dx >> #<data>) → X/C
Bcc	<label>	8,16	If Condition True, Then PC + 2 + d _n → PC
BCHG	Dy,<ea>x #<data>,<ea>x	8,32 8,32	~(<Bit Number> of Destination) → Z, Bit of Destination
BCLR	Dy,<ea>x #<data>,<ea>x	8,32 8,32	~(<Bit Number> of Destination) → Z; 0 → Bit of Destination
BRA	<label>	8,16	PC + 2 + d _n → PC
BSET	Dy,<ea>x #<data>,<ea>x	8,32 8,32	~(<Bit Number> of Destination) → Z; 1 → Bit of Destination
BSR	<label>	8,16	SP - 4 → SP; next sequential PC → (SP); PC + 2 + d _n → PC
BTST	Dy,<ea>x #<data>,<ea>x	8,32 8,32	~(<Bit Number> of Destination) → Z
CLR	<ea>x	8,16,32	0 → Destination
CMPI	#<data>,Dx	32	Destination - Immediate Data
CMP	<ea>y,Dx	32	Destination - Source
CMPA	<ea>y,Ax	32	Destination - Source
CPUSHL	(Ax)	none	Push and Invalidate Cache Line
DIVS	<ea>y,Dx	16 32	Dx / <ea>y → Dx {16-bit Remainder; 16-bit Quotient} Dx / <ea>y → Dx {32-bit Quotient} Signed operation
DIVU	<ea>y,Dx	16	Dx / <ea>y → Dx {16-bit Remainder; 16-bit Quotient} Dx / <ea>y → Dx {32-bit Quotient} Unsigned operation
EOR	Dy,<ea>x	32	Source ^ Destination → Destination
EORI	#<data>,Dx	32	Immediate Data ^ Destination → Destination
EXT	Dx Dx	8 → 16 16 → 32	Sign-Extended Destination → Destination
EXTB	Dx	8 → 32	Sign-Extended Destination → Destination
HALT	none	none	Enter Halted State
JMP	<ea>	none	Address of <ea> → PC
JSR	<ea>	32	SP - 4 → SP; next sequential PC → (SP); <ea> → PC
LEA	<ea>y,Ax	32	<ea> → Ax
LINK	Ax,#<data>	16	SP - 4 → SP; Ax → (SP); SP → Ax; SP + d16 → SP
LSL	Dy,Dx #<data>,Dx	32 32	X/C ← (Dx << Dy) ← 0 X/C ← (Dx << #<data>) ← 0
LSR	Dy,Dx #<data>,Dx	32 32	0 → (Dx >> Dy) → X/C 0 → (Dx >> #<data>) → X/C
MAC	Ry,Rx <shift> Ry,Rx <shift>,<ea>y,Rw	16 × 16 + 32 → 32 32 → 32	ACC + (Ry × Rx){<< 1 >> 1} → ACC ACC + (Ry × Rx){<< 1 >> 1} → ACC; (<ea>y(&MASK)) → Rw

INSTRUCTION	OPERAND SYNTAX	OPERAND SIZE	OPERATION
SUBX	Dy,Dx	32	Destination - Source - X → Destination
SWAP	Dx	16	MSW of Dx ←→ LSW of Dx
TRAP	none	none	SP - 4 → SP; PC → (SP); SP - 2 → SP; SR → (SP); SP - 2 → SP; Format → (SP); Vector Address → PC
TRAPF	none #<data>	none 16 32	PC + 2 → PC PC + 4 → PC PC + 6 → PC
TST	<ea>y	8,16,32	Set Condition Codes
UNLK	Ax	32	Ax → SP; (SP) → Ax; SP + 4 → SP
WDDATA	<ea>y	8,16,32	<ea>y → DDATA port
WDEBUG	<ea>y	2 x 32	<ea>y → Debug Module

1.3.2 MAC Module

The MAC unit provides a common set of simple DSP operations and speeds the execution of the integer multiply instructions in the ColdFire core. It provides functionality in three related areas: faster multiplications of signed and unsigned operands; and new miscellaneous register operations. Multiplies of 16x16 and 32x32 with 32-bit accumulates are supported. The MAC has a single clock issue for 16x16 multiplies and implements a 3-stage execution pipeline.

1.3.3 Hardware Divide Module

The MCF5206e processor includes a hardware divider which performs a number of integer divide operations. The supported divide functions include: 32/16 producing a 16-bit quotient and 16-bit remainder, 32/32 producing a 32-bit quotient, and 32/32 producing a 32-bit remainder.

The hardware divide function provides enhanced functionality, particularly in printing applications. With graphics-based printing this has resulted in as much as 15 percent performance improvement.

1.3.4 Instruction Cache

The instruction cache improves system performance by providing cached instructions to the execution unit in a single clock. The MCF5206e processor uses a 4K-byte, direct-mapped instruction cache to achieve 50 MIPS at 54MHz. The cache is accessed by physical addresses, where each 16-byte line consists of an address tag and a valid bit.

The instruction cache also includes a bursting interface for 32 bit, 16 bit, and 8 bit port sizes to quickly fill cache lines.

1.3.5 Internal SRAM

The 8 KByte on-chip SRAM provides one clock-cycle access for the ColdFire core. This SRAM can store processor stack and critical code or data segments to maximize performance.

1.3.6 DRAM Controller

The MCF5206e DRAM controller provides a glueless interface for as many as two banks of DRAM, each of which can be from 128 Kbytes to 256 Mbytes in size. The controller supports an 8 bit, 16 bit, or 32 bit data bus. A unique addressing scheme allows for increases in system memory size without rerouting address lines and rewiring boards. The controller operates in fast page mode, burst-page mode, or in normal mode, and supports EDO DRAMs.

DRAM operations are available to other external bus masters. The DRAM controller can generate $\overline{\text{CAS}}$ and $\overline{\text{RAS}}$ for an external master and can continue to manage refresh requests.

1.3.7 Direct Memory Access (DMA)

The MCF5206e provides 2 fully programmable DMA channels for quick data transfer. Single- and dual-address mode is provided with the ability to program bursting and cycle steal. Data transfers are 32 bits in length with packing and unpacking supported, along with an auto-alignment option for efficient block transfers. DMA transfers can be initiated via three mechanisms: S/W initiated; external requests; or from a UART interrupt.

1.3.8 UART modules

Two full duplex UART modules contain independent receivers and transmitters that can be clocked by the UART internal timer. This timer is clocked by the system clock or an external clock supplied by a TIN pin. Data formats can be 5, 6, 7, or 8 bits with even, odd, or no parity, and as many as 2 stop bits in 1/16 increments. Four-byte receive buffers and two-byte transmit buffers minimize CPU service calls. The UART modules also provides several error-detection and maskable-interrupt capabilities. Modem support includes request-to-send (RTS) and clear-to-send (CTS) lines.

The system clock provides the clocking function via a programmable prescaler. You can select full duplex, autoecho loopback, local loopback, and remote loopback modes. The programmable UARTs can interrupt the CPU on various normal or error-condition events.

1.3.9 Timer Module

The timer module includes two general-purpose timers, each of which contains a free-running 16-bit timer for use in any of three modes. One mode captures the timer value with an external event. Another mode triggers an external signal or interrupts the CPU when the timer reaches a set value, while a third mode counts external events. The timer unit has an 8-bit prescaler that allows for programming the clock input frequency, which is derived from the system clock. The programmable timer-output pin generates either an active-low pulse or toggles the output.

1.3.10 Motorola Bus (M-Bus) Module

The M-Bus interface is a two-wire, bidirectional serial bus that exchanges data between devices and is compatible with the I²C Bus standard. The M-Bus minimizes the interconnection between devices in the end system and is best suited for applications that

need occasional bursts of rapid communication over short distances among several devices. Bus capacitance and the number of unique addresses limit the maximum communication length and the number of devices that can be connected.

1.3.11 System Interface

The MCF5206e processor provides a glueless interface to 8-, 16-, and 32-bit SRAM, ROM, and peripheral devices with independent programmable control of the assertion and negation of chip selects and write enables. Programmable address and data-hold times can be extended for a compatible interface to external devices and memory. The MCF5206e also supports bursting ROMs.

1.3.11.1 EXTERNAL BUS INTERFACE. The bus interface controller transfers information between the ColdFire core and memory, peripherals, or other masters on the external bus. The external bus interface provides as many as 28 bits of address bus space, a 32-bit data bus, and all associated control signals. This interface implements an extended synchronous protocol that supports bursting operations. For nonsynchronous external memory and peripherals, the MCF5206e processor provides an alternate asynchronous bus transfer acknowledgment signal.

Simple two-wire request/acknowledge bus arbitration between the MCF5206e processor and another bus master, such as a DMA device, is glueless with arbitration handled internal to the MCF5206e processor. Alternately, an external bus arbiter can control more complex three-wire (request, grant, busy) multiple-master bus arbitration, allowing overlapped bus arbitration with one clock-bus handovers.

1.3.11.2 CHIP SELECTS . Eight programmable chip select outputs provide signals that enable external memory and peripheral circuits for automatic wait-state insertion. These signals also interface to 8 bit, 16 bit, or 32 bit ports. In addition, other external bus masters can access chip selects. The upper four chip selects are multiplexed with A[27:24] of the address bus and the four write enables. The base address, access permissions, and timing waveforms are all programmable with configuration registers.

1.3.12 8-Bit Parallel Port (General-Purpose I/O)

An 8-bit general-purpose programmable parallel port serves as either an input or an output on a bit-by-bit basis. The parallel port is multiplexed with PST[3:0] and DDATA[3:0] debug signals.

1.3.13 Interrupt Controller

The interrupt controller provides user-programmable control of three or seven external interrupt and five internal peripheral interrupts. You can program each internal interrupt to any one of seven interrupt levels and four priority levels within each of these levels. You can configure the three external interrupt signals as either fixed interrupt levels 1, 4, and 7, or as a seven-level encoded interrupt. You can program the external interrupts to any one of the four priority levels within the respective interrupt levels.

1.3.14 System Protection

The MCF5206e processor contains a 16-bit software watchdog timer with an 8-bit prescaler. The programmable software watchdog timer provides either a level 7 interrupt or a hardware reset on timeout. The MCF5206e processor also contains a reset status register that indicates the cause of the last reset.

1.3.15 JTAG

To help with system diagnostics and manufacturing testing, the MCF5206e processor includes dedicated user-accessible test logic that complies with the IEEE 1149.1 standard for boundary scan testability, often referred to as Joint Test Action Group, or JTAG. For more information, refer to the IEEE 1149.1 standard.

1.3.16 System Debug Interface

The ColdFire processor core debug interface supports real-time trace and background debug mode. A four-pin Background Debug Mode (BDM) interface provides system debug. The BDM is a proper subset of the BDM interface provided on Motorola's 683XX Family of parts.

In real-time trace, four status lines provide information on processor activity in real time (PST pins). A 4-bit wide debug data bus (DDATA) displays operand data, which helps track the machine's dynamic execution path as the change-of-flow instructions execute. These signals are multiplexed with an 8-bit parallel port for application development, which does not use real-time trace.

1.3.17 Pinout and Package

The MCF5206e device is supplied in a 160-pin plastic quad flat pack package, at speeds of 45 MHz and 54 MHz, and is pin-compatible with the MCF5206 (DMA is muxed with timer). It is available in 3.3V, with 5V-tolerant I/O.

SECTION 2 SIGNAL DESCRIPTION

2.1 INTRODUCTION

Figure 2-1 displays the block diagram of the MCF5206e along with the signal interface. This section describes the MCF5206e input and output signals. The descriptions are grouped according to functionality (refer to Table 2-1).

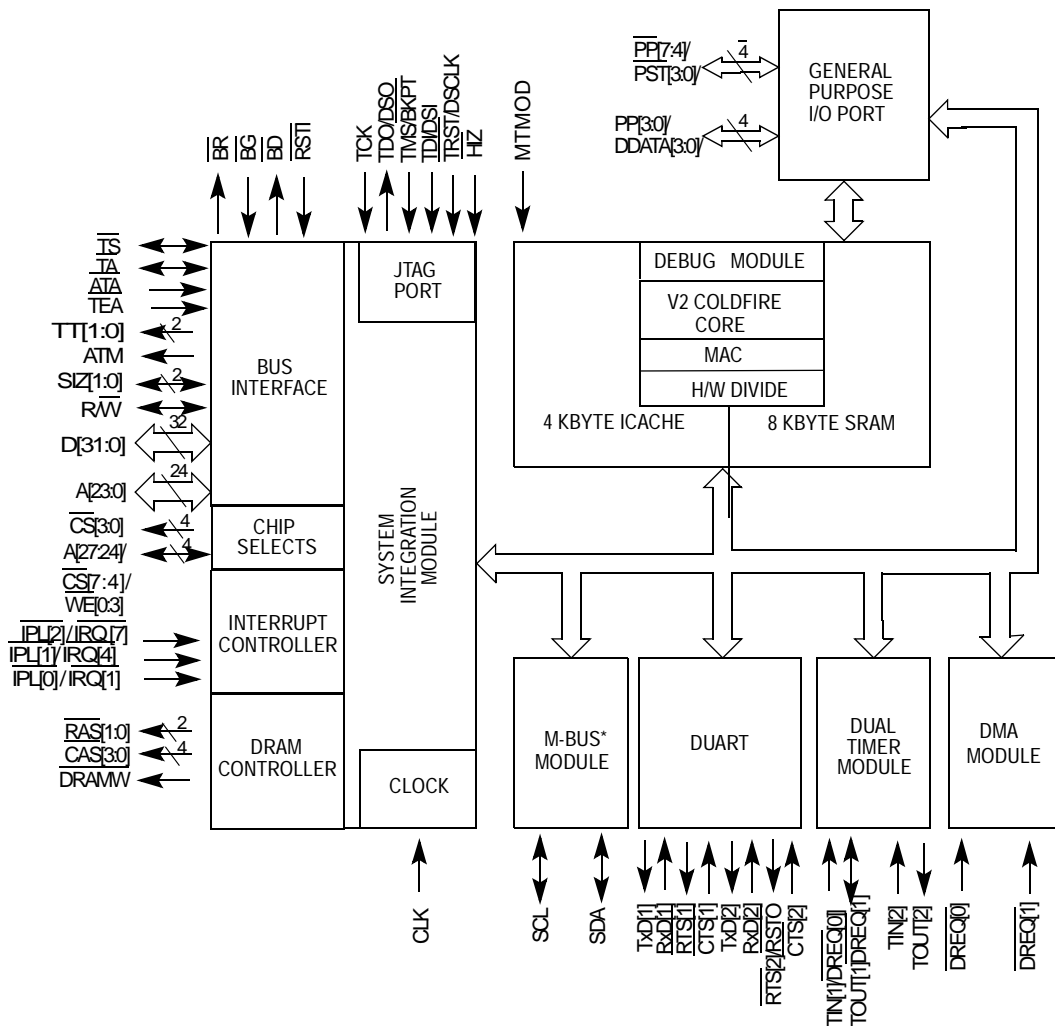

*M-Bus is compatible with Philips' I²C interface

Figure 2-1. MCF5206e Block Diagram

NOTE

The terms *assert* and *negate* are used throughout this section to avoid confusion when dealing with a mixture of active-low and active-high signals. The term *assert* or *assertion* indicates that a signal is active or true, independent of the level represented by a high or low voltage. The term *negate* or *negation* indicates that a signal is inactive or false.

Table 2-1. MCF5206e Signal Index

SIGNAL NAME	MNEMONIC	FUNCTION	INPUT/ OUTPUT
Address[27:24]/ Chip Select[7:4]/ Write Enable[3:0]	A[27:24]/ CS[7:4]/ WE[3:0]	Upper four bits of the address bus/ Upper four chip selects enable peripherals at programmed addresses/ Write enables select individual bytes in memory	In,Out/ Out/ Out
Address	A[23:0]	Lower 24 bits of the address bus. A[4:2] indicate the interrupt level during an IACK cycle	In,Out
Data	D[31:0]	Data bus used to transfer byte, word, or longword data	In,Out
Chip Select[3:0]	CS[3:0]	Enables peripherals at programmed addresses. CS[1] can indicate IACK during an interrupt acknowledge cycle. CS[0] provides relocatable boot ROM capability	Out
Interrupt Priority Level/ Interrupt Request	IPL[2]/IRQ[7] IPL[1]/IRQ[4] IPL[0]/IRQ[1]	Provides encoded interrupt priority level to processor/ Three individual external interrupts set to levels 7, 4, 1	In/ In
Read/Write	RW	Identifies read and write data transfers	In,Out
Size	SIZ[1:0]	Indicates the data transfer size	In,Out
Transfer Type	TT[1:0]	Indicates the transfer type: normal, CPU space/Interrupt acknowledge or emulator mode	Out
Access Type & Mode	ATM	Time-multiplexed output signal indicating access type (instruction or data) and access mode (supervisor or user)	Out
Transfer Start	TS	Indicates the beginning of a bus cycle	In,Out
Transfer Acknowledge	TA	Synchronous transfer acknowledge. Asserted to indicate the successful completion of a bus transfer.	In,Out
Asynchronous Transfer Acknowledge	ATA	Asynchronous transfer acknowledge. Asserted to indicate the successful completion of a bus transfer	In
Transfer Error Acknowledge	TEA	Asserted to indicate an error condition exists for a bus transfer	In
Bus Request	BR	Asserted by the MCF5206e to request bus mastership	Out
Bus Grant	BG	Asserted by bus arbiter to grant bus mastership privileges to the MCF5206e	In
Bus Driven	BD	Indicates the MCF5206e has assumed explicit bus mastership of the external bus	Out
Clock Input	CLK	Input used to clock internal logic	In
Reset	RSTI	Processor reset	In
Row Address Strobe	RAS[1:0]	Row address strobe for external DRAM	Out
Column Address Strobe	CAS[3:0]	Column address strobe for external DRAM	Out
DRAM Write	DRAMW	Asserted on DRAM write cycles and negated on DRAM read cycles	Out
Receive Data	RxD[1], RxD[2]	Receive serial data input for UART 1 and UART 2	In
Transmit Data	TxD[1],TxD[2]	Transmit serial data output for UART 1 and UART 2	Out
Request-To-Send	RTS[1]	Indicates UART 1 is ready to receive data	Out
Request-To-Send/ Reset Out	RTS[2]/RSTO	RTS indicates UART 2 is ready to receive data/ RSTO is the reset out signal	Out/ Out
Clear-To-Send	CTS[1], CTS[2]	Indicates can transmit serial data for UART 1 and UART 2	In

Table 2-1. MCF5206e Signal Index (Continued)

SIGNAL NAME	MNEMONIC	FUNCTION	INPUT/ OUTPUT
DMA Request Input	DREQ[0], DREQ[1]	External DMA request inputs for channels 0 & 1	In
Timer Input/TIN[1] or DREQ[0]	TIN[1], TIN[2]	Clock input to timer or trigger input for timer value capture logic	In
Timer Output/TOUT[1] or DREQ[1]	TOUT[1], TOUT[2]	Timer output waveform or pulse generation	In,Out
Serial Clock Line	SCL	Clock signal for M-Bus module operation	In,Out
Serial Data Line	SDA	Serial data port for M-Bus module operation	In,Out
General Purpose I/O/ Processor Status	PP[7:4]/PST[3:0]	Upper 4 bits of general purpose I/O port / Internal processor status.	In,Out/ Out
General Purpose I/O/ Debug Data	PP[3:0]/DDATA[3:0]	Lower 4 bits of general purpose I/O port / Captured processor data and break-point status debug data	In,Out/ Out
Test Clock	TCK	JTAG clock signal	In
Test Data Output/ Development Serial Output	TDO/DSO	JTAG serial data out/ Debug serial out	Out/ Out
Test Mode Select/ Break Point	TMS/BKPT	JTAG mode select/ Debug mode breakpoint	In/ In
Test Data Input / Development Serial Input	TDI/DSI	JTAG serial data input/ Debug serial input	In/ In
Test Reset/ Development Serial Clock	TRST/DSCLK	Asynchronous JTAG reset input/ Debug serial clock input	In/ In
Motorola Test Mode	MTMOD	Selects JTAG or Debug signals	In
High Impedance	HIZ	Output buffer three-state and master reset control	In

2.2 ADDRESS BUS

These three-state bidirectional address signals indicate the following:

Table 2-2. Address Bus

TYPE OF BUS TRANSFER/MEMORY SPACE ACCESSED	ADDRESS BUS
Interrupt Acknowledge Transfer	A[27:5] = \$7FFFF, A[1:0]=\$0, A[4:2] Interrupt Level being serviced
Chip Select Transfer	Address of byte or most significant byte of word or longword being accessed
DRAM Transfer	Row Address and Column Address indicating byte or most significant byte of word or longword being accessed
Default Memory	Address of byte or most significant byte of word or longword being accessed

The address bus includes 24 dedicated address signals, A[23:0], and supports as many as four additional configurable address signals, A[27: 24] (refer to **Section 7.3.2.10 Pin Assignment Register (PAR)**). The address will appear only on the pins configured to be address signals.

When an external master is using the MCF5206e as a slave DRAM controller, the external master asserts \overline{TS} and places the transfer address on the address pins. The external master then three-states the address signals and the MCF5206e drives the row address and the column address on the address bus at the appropriate times.

2.2.1 Address Bus (A[27:24]/ $\overline{\text{CS}}$ [7:4]/ $\overline{\text{WE}}$ [0:3])

These multiplexed pins can serve as the most significant nibble of the address pins, chip-selects, or as write enables. Programming the Pin Assignment Register (PAR) in the SIM determines the function of each of these four multiplexed pins. During reset, these pins are configured to be write enables.

When any of these pins are enabled as address lines in the PAR, they represent the most significant bits of the address bus. A maximum of 256 Mbytes of memory is addressable when all of these pins are programmed as address signals. Any of these pins that are programmed as address lines have the same timing as the lower address lines A[23:0]. All address lines become valid during the same clock phase $\overline{\text{TS}}$ is asserted.

2.2.2 Address Bus (A[23:0])

The three-state bidirectional signals are the 24 least significant bits of the address bus. For chip select and default memory transfers initiated by the ColdFire[®] core, the MCF5206e outputs the address and increments the lower bits during burst transfers, allowing the address bus to be directly connected to external memory. For DRAM transfers initiated by the ColdFire core, the MCF5206e outputs the row address and column address as specified by the DRAM control registers.

The MCF5206e does not output the address during alternate or external master initiated chip select and default memory transfers. When an external master is using the MCF5206e as a slave DRAM controller, the external master asserts $\overline{\text{TS}}$ and places the row and column address on the address pins. The external master drives the address signals to a high-impedance state and the MCF5206e then drives the row address and the column address on the address bus at the appropriate times.

2.2.3 Data Bus (D[31:0])

The three-state bidirectional signals provide a nonmultiplexed general purpose data path between the MCF5206e and all other devices in the system. During a read bus transfer, data is registered from the bus on the rising clock edge during which $\overline{\text{TA}}$ is asserted, or during the rising clock in which internal asynchronous transfer acknowledge is asserted or internal transfer acknowledge is asserted.

The data bus port width is initially configured by the values on $\overline{\text{IPL}}$ [1]/ $\overline{\text{IRQ}}$ [4] and $\overline{\text{IPL}}$ [0]/ $\overline{\text{IRQ}}$ [1] during reset. Port width is individually programmed for each chip select region and DRAM bank, and is globally configured for a memory region not matching chip select settings or DRAM memory, referred to as default memory. The data bus transfers byte, word, or longword sized data. All 32 bits of the data bus are driven during writes, regardless of port width or operand size.

2.3 CHIP SELECTS

The MCF5206e provides as many eight programmable chip selects that can directly interface with SRAM, EPROM, EEPROM, and peripherals.

2.3.1 Chip Selects (A[27:24]/ $\overline{\text{CS}}$ [7:4]/ $\overline{\text{WE}}$ [0:3])

These multiplexed pins can serve as the most significant nibble of the address pins, chip-selects, or as write enables. Programming the Pin Assignment Register (PAR) in the SIM determines the function of each of these four multiplexed pins. During reset, these pins are configured to be write enables.

The active-low chip select output signals provide control for peripherals and memory. You can program each chip select for an address location, with masking capabilities, port size and burst-capability indication, wait-state generation, and internal/external termination. A reset disables these chip selects.

2.3.2 Chip Selects ($\overline{\text{CS}}$ [3:0])

These active-low output signals provide control for peripherals and memory. $\overline{\text{CS}}$ [3] and $\overline{\text{CS}}$ [2] are functionally equivalent to the upper order chip selects previously described. However, $\overline{\text{CS}}$ [1] can also be programmed to assert during CPU space accesses including interrupt-acknowledge cycles. $\overline{\text{CS}}$ [0] provides a special function as a global chip select that lets you relocate boot ROM at any defined address space. $\overline{\text{CS}}$ [0] is the only chip select initialized during reset. Port size and termination (internal vs. external) for $\overline{\text{CS}}$ [0] are configured by the logic levels on $\overline{\text{IPL}}$ [2]/ $\overline{\text{IRQ}}$ [7], $\overline{\text{IPL}}$ [1]/ $\overline{\text{IRQ}}$ [4], and $\overline{\text{IPL}}$ [0]/ $\overline{\text{IRQ}}$ [1] during reset.

2.3.3 Byte Write Enables (A[27:24]/ $\overline{\text{CS}}$ [7:4]/ $\overline{\text{WE}}$ [0:3])

These multiplexed pins can serve as the most significant nibble of the address pins, chip-selects, or as write enables. Programming the Pin Assignment Register (PAR) in the SIM determines the function of each of these four multiplexed pins. During reset, these pins are configured to be write enables.

The active-low write enable output signals provide control for peripherals and memory during write transfers. During write transfers, these outputs indicate which bytes within a longword transfer are being selected and which bytes of the data bus will be used for the transfer. $\overline{\text{WE}}$ [0] controls D[31:24], $\overline{\text{WE}}$ [1] controls D[23:16], $\overline{\text{WE}}$ [2] controls D[15:8] and $\overline{\text{WE}}$ [3] controls D[7:0]. These generated signals provide byte data select signals that are decoded from the $\overline{\text{SIZ}}$ [1:0] and A[1:0] signals in addition to the programmed port size and burst capability of the memory being accessed, as shown in Table 2-3.

2.4 INTERRUPT CONTROL SIGNALS

The interrupt signals supply the external interrupt requests or interrupt level to the MCF5206e. During reset, these pins configure the processor for the number of wait states and port size for the boot chip select ($\overline{\text{CS}}$ [0]).

Table 2-3. Byte Write Enable Signals

TRANSFER SIZE	PORT SIZE	BURST	SIZ[1]	SIZ[0]	A1	A0	$\overline{\text{WE}}[0]$	$\overline{\text{WE}}[1]$	$\overline{\text{WE}}[2]$	$\overline{\text{WE}}[3]$		
							D31-D24	D23-D16	D15-D8	D7-D0		
BYTE	8-bit	0	0	1	0	0	0	1	1	1		
					0	1	0	1	1	1		
					1	0	0	1	1	1		
		1	0	1	0	0	0	1	1	1	1	
					0	1	0	1	1	1		
					1	0	0	1	1	1		
	0		0	1	0	0	0	1	1	1	1	
					0	1	1	0	1	1		
					1	0	0	1	1	1		
		1	0	1	0	0	0	1	1	1	1	
					0	1	1	0	1	1		
					1	0	0	1	1	1		
	0		0	1	0	0	0	1	1	1	1	
					0	1	1	0	1	1		
					1	0	1	1	0	1		
		1	0	1	0	0	0	1	1	1	1	
					0	1	1	0	1	1		
					1	0	0	1	1	1		
	WORD		8-bit	0	0	1	0	0	0	1	1	1
							0	1	0	1	1	1
							1	0	0	1	1	1
		1		1	0	0	0	0	1	1	1	1
						0	1	0	1	1	1	
						1	0	0	1	1	1	
0			1	0	0	0	0	0	1	1	1	
					1	0	0	0	1	1		
					0	0	0	0	1	1		
		1	1	0	0	0	0	0	1	1	1	
					0	0	0	0	1	1		
					1	0	0	0	1	1		
0			1	0	0	0	0	0	1	1	1	
					1	0	1	1	0	0		
					0	0	0	0	1	1		
		1	1	0	0	0	0	0	1	1	1	
					1	0	1	1	0	0		
					0	0	0	0	1	1		

Table 2-3. Byte Write Enable Signals (Continued)

TRANSFER SIZE	PORT SIZE	BURST	SIZ[1]	SIZ[0]	A1	A0	$\overline{WE}[0]$	$\overline{WE}[1]$	$\overline{WE}[2]$	$\overline{WE}[3]$
							D31-D24	D23-D16	D15-D8	D7-D0
LONGWORD	8 bit	0	0	1	0	0	0	1	1	1
					0	1	0	1	1	1
					1	0	0	1	1	1
					1	1	0	1	1	1
		1	0	0	0	0	0	1	1	1
					0	1	0	1	1	1
					1	0	0	1	1	1
					1	1	0	1	1	1
	16 bit	0	1	0	0	0	0	0	1	1
					1	0	0	0	1	1
		1	0	0	0	0	0	0	1	1
					1	0	0	0	1	1
	32 bit	0	0	0	0	0	0	0	0	0
		1	0	0	0	0	0	0	0	0
LINE	8 bit	0	0	1	0	0	0	1	1	1
					0	1	0	1	1	1
					1	0	0	1	1	1
					1	1	0	1	1	1
		1	1	1	0	0	0	1	1	1
					0	1	0	1	1	1
					1	0	0	1	1	1
					1	1	0	1	1	1
	16 bit	0	1	0	0	0	0	0	1	1
					1	0	0	0	1	1
		1	1	1	0	0	0	0	1	1
					1	0	0	0	1	1
	32-Bit	0	0	0	0	0	0	0	0	0
		1	1	1	1	0	0	0	0	0

2.4.1 Interrupt Priority Level/ Interrupt Request ($\overline{IPL}[2]/\overline{IRQ}[7], \overline{IPL}[1]/\overline{IRQ}[4], \overline{IPL}[0]/\overline{IRQ}[1]$)

You can program these three active-low input pins as either interrupt priority level signals ($\overline{IPL}[2:0]$) or predefined interrupt request pins ($\overline{IRQ}[7], \overline{IRQ}[4], \overline{IRQ}[1]$). Programming the Pin Assignment Register (PAR) in the SIM determines the function of these pins. During reset, these pins are configured to be predefined interrupt requests.

When these pins are programmed to be interrupt priority level signals, $\overline{IPL}[2:0]$ signals the priority level (7-1) of an external interrupt; $\overline{IPL}[2:0]=000$ (level 7) indicates the highest unmaskable interrupt, while $\overline{IPL}[2:0]=111$ (level 0) indicates no interrupt request. When these pins are programmed to be interrupt request signals, the assertion of $\overline{IRQ}[7]$ generates a level 7 interrupt, $\overline{IRQ}[4]$ generates a level 4 interrupt, and $\overline{IRQ}[1]$ generates a level 1 interrupt, as shown in Table 2-4.

Freescale Semiconductor, Inc.

Table 2-4. Interrupt Levels for Encoded External Interrupts

$\overline{\text{IPL}}[2]/\overline{\text{IRQ}}[7]$	$\overline{\text{IPL}}[1]/\overline{\text{IRQ}}[4]$	$\overline{\text{IPL}}[0]/\overline{\text{IRQ}}[1]$	INTERRUPT LEVEL INDICATED
0	0	0	7
0	0	1	6
0	1	0	5
0	1	1	4
1	0	0	3
1	0	1	2
1	1	0	1
1	1	1	No Interrupt

During reset, the interrupt-priority level/interrupt request pins are sampled to define port size and wait-state generation for $\overline{\text{CS}}$ Tables 2-5 and 2-6 show the reset values for wait states and port size for $\overline{\text{CS}}[0]$ based on the these pins.

Table 2-5. Boot $\overline{\text{CS}}[0]$ Automatic Acknowledge (AA) Enable

$\overline{\text{IPL}}[2]/\overline{\text{IRQ}}[7]$	INITIAL $\overline{\text{CS}}[0]$ AA
0	Disabled
1	Enabled with 15 wait states

Table 2-6. Interrupt Request Encodings for $\overline{\text{CS}}[0]$

$\overline{\text{IPL}}[1]/\overline{\text{IRQ}}[4]$	$\overline{\text{IPL}}[0]/\overline{\text{IRQ}}[1]$	INITIAL $\overline{\text{CS}}[0]$ PORT SIZE
0	0	32 bit port
0	1	8 bit port
1	0	16 bit port
1	1	16 bit port

2.5 BUS CONTROL SIGNALS

2.5.1 Read/Write (R/W) Signal

This three-state bidirectional signal defines the data transfer direction for the current bus cycle. A high (logic one) level indicates a read cycle while a low (logic zero) level indicates a write cycle. When an alternate bus master is controlling the bus, the MCF5206e monitors this signal to determine if chip select or DRAM control signals need to be asserted.

2.5.2 Size (SIZ[1:0])

These three-state bidirectional signals indicate the transfer data size for the bus cycle. When an alternate bus master is controlling the bus, the MCF5206e monitors these signals to determine the data size for asserting the appropriate memory control signals. Table 2-7 shows the definitions of the SIZ[1:0] encoding.

Table 2-7. Data Transfer Size Encoding

SIZ[1:0]	DATA TRANSFER SIZE
00	Longword
01	Byte
10	Word
11	Line

2.5.3 Transfer Type (TT[1:0])

These three-state output signals indicate the type of access for the current bus cycle. TT[1:0] are not sampled by the MCF5206e during alternate master transfers. Table 2-8 lists the definitions of the TT[1:0] encodings.

Table 2-8. Bus Cycle Transfer Type Encoding

TT[1:0]	TRANSFER TYPE
0 0	Normal Access
0 1	DMA Access
1 0	Emulator Access
1 1	CPU Space or Interrupt Acknowledge

2.5.4 Access Type and Mode (ATM)

This three-state output signal provides supplemental information for each transfer cycle type. ATM is not sampled by the MCF5206e during alternate master transfers. Table 2-9 lists the encoding for normal, debug and CPU space/interrupt-acknowledge transfer types.

Table 2-9. ATM Encoding

TRANSFER TYPE	INTERNAL TRANSFER MODIFIER	ATM (TS=0)	ATM (TS=1)
00 (Normal Access)	Supervisor Code	1	1
	Supervisor Data	0	1
	User Code	1	0
	User Data	0	0

Table 2-9. ATM Encoding (Continued)

TRANSFER TYPE	INTERNAL TRANSFER MODIFIER	ATM (TS=0)	ATM (TS=1)
01 (DMA Access)	DMA Data	1	0
10 (Debug Access)	Supervisor Code	1	1
	Supervisor Data	0	1
11 (CPU Space/ Acknowledge Access)	CPU Space - MOVEC Instruction	0	0
	Interrupt Acknowledge - level 7	1	0
	Interrupt Acknowledge - level 6	1	0
	Interrupt Acknowledge - level 5	1	0
	Interrupt Acknowledge - level 4	1	0
	Interrupt Acknowledge - level 3	1	0
	Interrupt Acknowledge - level 2	1	0
	Interrupt Acknowledge - level 1	1	0

2.5.5 Transfer Start (\overline{TS})

The MCF5206e asserts this three-state bidirectional active-low signal for one clock period to indicate the start of each bus cycle. During alternate master accesses, the MCF5206e monitors transfer start (\overline{TS}) to detect the start of each alternate master bus cycle to determine if chip select or DRAM control signals need to be asserted.

2.5.6 Transfer Acknowledge (\overline{TA})

This three-state bidirectional active-low synchronous signal indicates the completion of a requested data transfer operation. During transfers initiated by the MCF5206e, transfer acknowledge (\overline{TA}) is an input signal from the referenced slave device indicating completion of the transfer.

\overline{TA} is not used for termination during DRAM accesses initiated by the MCF5206e.

When an external master is controlling the bus, \overline{TA} may be driven as an output by the MCF5206e or may be driven by the referenced slave device to indicate the completion of the requested data transfer. If the alternate master requested transfer is to a chip select or default memory, the assertion of \overline{TA} is controlled by the number of wait states and the setting of the Alternate Master Automatic Acknowledge (EMAA) bit in the Chip Select Control Registers (CSCRs) or the Default Memory Control Register (DMCR). If the alternate master requested transfer is a DRAM access, \overline{TA} is driven by the MCF5206e as an output and asserted at the completion of the transfer.

2.5.7 Asynchronous Transfer Acknowledge (\overline{ATA})

This active-low asynchronous input signal indicates the completion of a requested data transfer operation. Asynchronous transfer acknowledge (\overline{ATA}) is an input signal from the referenced slave device indicating completion of the transfer. \overline{ATA} is synchronized internal to the MCF5206e.

NOTE

The internal synchronized version of asynchronous transfer acknowledge (\overline{ATA}) will be referred to as “internal asynchronous transfer acknowledge (\overline{ATA}).” Because of the time required to internally synchronize \overline{ATA} during a read cycle, data is latched on the falling edge of CLK when the internal \overline{ATA} is asserted. Consequently, data must remain valid for at least one and a half clock cycles after the assertion of \overline{ATA} . Similarly, during a write cycle, data is driven until the falling edge of CLK when the internal \overline{ATA} is asserted.

\overline{ATA} must be driven for one full clock to ensure that the MCF5206e properly synchronizes the signal. \overline{ATA} is not used for termination during DRAM accesses.

2.5.8 Transfer Error Acknowledge (\overline{TEA})

This active-low input signal is asserted by the external slave to indicate an error condition for the current transfer. The assertion of transfer error acknowledge (\overline{TEA}) causes the MCF5206e to immediately abort the bus cycle. The assertion of \overline{TEA} has precedence over the assertion of \overline{ATA} and \overline{TA} .

NOTE

\overline{TEA} can be asserted to a maximum of one clock after the assertion of \overline{ATA} and still be recognized.

\overline{TEA} has no affect during DRAM accesses.

2.6 BUS ARBITRATION SIGNALS**2.6.1 Bus Request (\overline{BR})**

This active-low output signal indicates to an external arbiter that the MCF5206e needs use of the bus for one or more bus cycles. \overline{BR} is negated when the MCF5206e begins an access to the external bus, and remains negated until another internal request occurs with \overline{BG} negated.

2.6.2 Bus Grant (\overline{BG})

An external arbiter asserts this active-low input signal to indicate that the MCF5206e can become master of the external bus at the next rising edge of CLK. When the arbiter negates \overline{BG} , the MCF5206e relinquishes the bus as soon as the current transfer is complete, provided the bus lock bit in the SIMR is not set. If the bus lock bit is set, the MCF5206e will retain bus mastership until the bus lock bit is cleared. The external arbiter must not grant the bus to any other master until the MCF5206e negates \overline{BD} .

2.6.3 Bus Driven ($\overline{\text{BD}}$)

The MCF5206e asserts this active-low output signal to indicate it has assumed explicit mastership of the external bus. The MCF5206e will assert $\overline{\text{BD}}$ if $\overline{\text{BG}}$ is asserted and either the MCF5206e has a pending bus transfer or the bus lock bit in the SIMR is set to 1. If the MCF5206e is granted mastership of the external bus, but does not have a pending bus transfer and the bus lock bit in the SIMR is cleared, the $\overline{\text{BD}}$ signal is not asserted (implicit mastership of the bus is assumed).

If $\overline{\text{BG}}$ is negated to the MCF5206e during a bus transfer and the bus lock bit in the SIMR is cleared, the MCF5206e completes the last transfer of the current access, negates $\overline{\text{BD}}$, and three-states all bus signals on the rising edge of CLK. If the MCF5206e loses bus ownership during an idle bus period with $\overline{\text{BD}}$ asserted and the bus lock bit in the SIMR cleared, the MCF5206e negates $\overline{\text{BD}}$ and three-states all bus signals on the next rising edge of CLK. If the MCF5206e loses bus ownership during an idle bus period with $\overline{\text{BD}}$ asserted and the bus lock bit in the SIMR set to 1, the MCF5206e continues to assert $\overline{\text{BD}}$ and maintains explicit ownership of the external bus until the bus lock bit in the SIMR is cleared.

2.7 CLOCK AND RESET SIGNALS

2.7.1 Clock Input (CLK)

CLK is the MCF5206e synchronous clock. CLK clocks or sequences the MCF5206e internal logic and external signals.

2.7.2 Reset ($\overline{\text{RSTI}}$)

Asserting the active-low $\overline{\text{RSTI}}$ input causes the MCF5206e processor to enter reset exception processing. When $\overline{\text{RSTI}}$ is recognized, the address bus, data bus, TT, SIZ, R/W, ATM and $\overline{\text{TS}}$ are three-stated; $\overline{\text{BR}}$ and $\overline{\text{BD}}$ are negated.

If $\overline{\text{RSTI}}$ is asserted with $\overline{\text{HIZ}}$ asserted, the MCF5206e enters master reset mode. In this reset mode, the entire MCF5206e (including the DRAM controller refresh circuitry) is reset. You must use master reset for all power-on resets.

If $\overline{\text{RSTI}}$ is asserted with $\overline{\text{HIZ}}$ negated, the MCF5206e enters normal reset mode. In this reset mode, the DRAM controller refresh circuitry is not reset and continues to generate refresh cycles at the programmed rate and with the programmed waveform timing.

2.7.3 Reset Out ($\overline{\text{RTS}}[2]/\overline{\text{RSTO}}$)

$\overline{\text{RTS}}[2]$ is multiplexed with the $\overline{\text{RSTO}}$ signal. Programming the Pin Assignment Register (PAR) in the SIM determines the function of this pin. During reset, this pin is configured to be $\overline{\text{RSTO}}$.

$\overline{\text{RSTO}}$ is an output that drives peripherals to reset. $\overline{\text{RSTO}}$ is asserted no more than two clocks after the assertion of $\overline{\text{RSTI}}$, and $\overline{\text{RSTO}}$ remains asserted for at least 31 clocks after

the negation of \overline{RSTI} . \overline{RSTO} is also asserted for at least 31 clocks on a software watchdog timeout that is programmed to generate a reset.

2.8 DRAM CONTROLLER SIGNALS

The following DRAM signals provide a glueless interface to external DRAM.

2.8.1 Row Address Strobes ($\overline{RAS}[1:0]$)

These active-low output signals provide control for the row address strobe (\overline{RAS}) input pins on industry-standard DRAMs. There is one \overline{RAS} output for each DRAM bank: $\overline{RAS}[0]$ controls DRAM bank 0 and $\overline{RAS}[1]$ controls DRAM bank 1. You can customize \overline{RAS} timing to match the specifications of the DRAM being used by programming the DRAMC Timing Register (see **Section 7.3.2.10 Pin Assignment Register (PAR)**).

2.8.2 Column Address Strobes ($\overline{CAS}[3:0]$)

These active-low output signals provide control for the column address strobe (\overline{CAS}) input pins on industry-standard DRAMs. The \overline{CAS} signals enable data byte lanes: $\overline{CAS}[0]$ controls access to D[31:24], $\overline{CAS}[1]$ to D[23:16], $\overline{CAS}[2]$ to D[15:8], and $\overline{CAS}[3]$ to D[7:0]. You should use $\overline{CAS}[3:0]$ for a 32 bit wide DRAM bank, $\overline{CAS}[1:0]$ for a 16 bit wide DRAM bank, and $\overline{CAS}[0]$ for an 8 bit wide DRAM bank. Table 2-10 shows which \overline{CAS} signals are asserted based on the operand size, the DRAM port size, and the address bits A[1:0]. You can customize \overline{CAS} timing to match the specifications of the DRAM by programming the DRAM Controller Timing Register (see **Section 10.4.2.2 DRAM Controller Timing Register (DCTR)**).

Table 2-10. \overline{CAS} Assertion

OPERAND SIZE	PORT SIZE	SIZ[1]	SIZ[0]	A[1]	A[0]	$\overline{CAS}[0]$	$\overline{CAS}[1]$	$\overline{CAS}[2]$	$\overline{CAS}[3]$
						D[31:24]	D[23:16]	D[15:8]	D[7:0]
BYTE	8 bit	0	1	0	0	0	1	1	1
				0	1	0	1	1	1
				1	0	0	1	1	1
				1	1	0	1	1	1
	16 bit	0	1	0	0	0	1	1	1
				0	1	1	0	1	1
				1	0	0	1	1	1
				1	1	1	0	1	1
	32 bit	0	1	0	0	0	1	1	1
				0	1	1	0	1	1
				1	0	1	1	0	1
				1	1	1	1	1	0

Table 2-10. CAS Assertion (Continued)

OPERAND SIZE	PORT SIZE	SIZ[1]	SIZ[0]	A[1]	A[0]	CAS[0]	CAS[1]	CAS[2]	CAS[3]
						D[31:24]	D[23:16]	D[15:8]	D[7:0]
WORD	8 bit	1	0	0	0	0	1	1	1
				0	1	0	1	1	1
				1	0	0	1	1	1
				1	1	0	1	1	1
	16 bit	1	0	0	0	0	0	1	1
				1	0	0	0	1	1
32 bit	1	0	0	0	0	0	1	1	
			1	0	1	1	0	0	
LONG WORD	8 bit	0	0	0	0	0	1	1	1
				0	1	0	1	1	1
				1	0	0	1	1	1
				1	1	0	1	1	1
	16 bit	0	0	0	0	0	0	1	1
				1	0	0	0	1	1
32 bit	0	0	0	0	0	0	0	0	
LINE	8 bit	1	1	0	0	0	1	1	1
				0	1	0	1	1	1
				1	0	0	1	1	1
				1	1	0	1	1	1
	16 bit	1	1	0	0	0	0	1	1
				1	0	0	0	1	1
32 bit	1	1	0	0	0	0	0	0	

2.8.3 DRAM Write ($\overline{\text{DRAMW}}$)

This active-low output signal is asserted during DRAM write cycles and negated during DRAM read cycles. The $\overline{\text{DRAMW}}$ signal is negated during refresh cycles and is provided (in addition to the R/W signal) to allow refreshes to occur during non-DRAM cycles (regardless of the state of the R/W signal). The R/W signal indicates the direction of all bus transfers, while $\overline{\text{DRAMW}}$ is valid only during DRAM transfers.

2.9 UART MODULE SIGNALS

The signals listed below transfer serial data between the two UART modules (UART 1 and UART 2) and external peripherals.

2.9.1 Receive Data (RxD[1], RxD[2])

These are the inputs on which serial data is received by the UART modules. RxD[1] corresponds to UART 1 and RxD[2] corresponds to UART 2. Data is sampled on RxD[1] and RxD[2] on the rising edge of the serial clock source, with the least significant bit received first.

2.9.2 Transmit Data (TxD[1], TxD[2])

The UART modules transmit serial data on these outputs. TxD[1] corresponds to UART 1 and TxD[2] corresponds to UART 2. Data is transmitted on the falling edge of the serial clock source, with the least significant bit transmitted (LSB) first. When no data is being transmitted or the transmitter is disabled, these two signals are held high. TxD[1] and TxD[2] are also held high in local loopback mode.

2.9.3 Request To Send ($\overline{\text{RTS}}[1]$, $\overline{\text{RTS}}[2]/\overline{\text{RSTO}}$)

$\overline{\text{RTS}}[2]$ is multiplexed with the $\overline{\text{RSTO}}$ signal. Programming the Pin Assignment Register (PAR) in the SIM determines the function of this pin. During reset, this pin is configured to be $\overline{\text{RSTO}}$.

The request-to-send output indicates to the peripheral device that the UART module is ready to receive data. $\overline{\text{RTS}}[1]$ corresponds to UART 1 and $\overline{\text{RTS}}[2]$ corresponds to UART 2.

2.9.4 Clear To Send ($\overline{\text{CTS}}[1]$, $\overline{\text{CTS}}[2]$)

Peripherals drive these inputs to indicate to the UART module that it can begin data transmission. $\overline{\text{CTS}}[1]$ corresponds to UART 1 and $\overline{\text{CTS}}[2]$ corresponds to UART 2.

2.10 TIMER MODULE SIGNALS

The signal descriptions that follow are the external interface to the two general purpose timer modules (Timer 1 and Timer 2).

2.10.1 Timer Input (TIN[2], TIN[1])

You can program the timer input to be the clock for the timer module. You can also program the timer module to trigger a capture on the rising edge, falling edge, or both edges of the timer input. TIN[1] corresponds to Timer 1 and TIN[2] corresponds to Timer 2. TIN[1] is muxed with DREQ[0]. The reset state of the dual function TIN[1] pin is for timer operation.

2.10.2 Timer Output (TOUT[2], TOUT[1])

The programmable timer output pulses or toggles when the timer reaches the programmed count value. TOUT[1] corresponds to Timer 1 and TOUT[2] corresponds to Timer 2. The reset state of the dual function TOUT[1] pin is for timer operation.

2.11 DMA MODULE SIGNALS

The signal descriptions that follow are the external interface to the two DMA channels (DREQ[0] and DREQ[1]).

2.11.1 DMA Request (DREQ[0], DREQ[1])

DREQ[0] is multiplexed with the TIN[1] pin and DREQ[1] is multiplexed with the TOUT[1] pin. Refer to Figure 2.1. The reset state of the timer/DMA dual function pins is for the timer

mode of operation. Programming the Pin Assignment Register (PAR) in the SIM determines the function of these pins. The DMA channels can be programmed for single- and dual-address mode, with the ability to program bursting and cycle steal. Data transfers are 32 bits in length with packing and unpacking supported, along with an auto-alignment option for efficient block transfers.

2.12 M-BUS MODULE SIGNALS

The M-Bus module acts as a quick two-wire, bidirectional serial interface between the MCF5206e and peripherals with an M-Bus interface (e.g., LED controller, A-to-D converter, D-to-A converter). All devices connected to the M-Bus must have open-drain or open-collector outputs.

2.12.1 M-Bus Serial Clock (SCL)

This bidirectional, open-drain signal is the clock signal for M-Bus module operation. It is controlled by the M-Bus module when the bus is in master mode; all M-Bus devices drive this signal to synchronize M-Bus timing.

2.12.2 M-Bus Serial Data (SDA)

This bidirectional, open-drain signal is the data input/output for the serial M-Bus interface.

2.13 GENERAL PURPOSE I/O SIGNALS

2.13.1 General Purpose I/O (PP[7:4]/PST[3:0])

These general purpose I/O signals are multiplexed with the processor status signals, PST[3:0]. Programming the Pin Assignment Register (PAR) in the SIM determines the

These outputs indicate the MCF5206e processor status. During debug mode, the timing is synchronous with the processor clock (CLK) and the status is not related to the current bus transfer. Table 2-11 shows the encodings of PST[3:0].

Table 2-11. Processor Status Encodings

PST[3:0]	DEFINITION
0000	Continue execution
0001	Begin execution of an instruction
0010	Reserved
0011	Entry into user mode
0100	Begin execution of PULSE instruction
0101	Begin execution of taken branch
0110	Reserved
0111	Begin execution of RTE instruction
1000	Reserved
1001	Reserved
1010	Reserved
1011	Reserved
1100	† Exception processing
1101	† Emulator mode entry exception processing
1110	† Processor is stopped, waiting for interrupt
1111	† Processor is halted
† These encodings are asserted for multiple cycles.	

2.14.2 Debug Data (PP[3:0]/DDATA[3:0])

The debug data signals are multiplexed with general purpose I/O signals. Programming the Pin Assignment Register (PAR) in the SIM determines the function of these pins. During reset, these pins are configured as general purpose inputs.

The DDATA[3:0] outputs display captured processor data and breakpoint status. See **Section 15: Debug Support** section for additional information on this bus.

2.14.3 Development Serial Clock ($\overline{\text{TRST}}$ /DSCLK)

The $\overline{\text{MTMOD}}$ signal determines the function of this dual-purpose pin. If $\overline{\text{MTMOD}}=0$, the $\overline{\text{TRST}}$ function is selected. If $\overline{\text{MTMOD}}=1$, the DSCLK function is selected. $\overline{\text{MTMOD}}$ should not be changed while $\overline{\text{RSTI}} = 1$.

The DSCLK input signal is used as the development serial clock for the serial interface to the debug module. The maximum frequency for the DSCLK signal is 1/2 the CLK frequency. See **Section 15: Debug Support** section for additional information on this signal.

2.14.4 Break Point (TMS/BKPT)

The MTMOD signal determines the function of this dual-purpose pin. If MTMOD = 0, then the TMS function is selected. If MTMOD = 1, the BKPT function is selected. MTMOD should not change while $\overline{RSTI} = 1$.

The assertion of the active-low \overline{BKPT} input signal causes a hardware breakpoint to occur in the processor when in the Debug mode. See **Section 15: Debug Support** section for additional information on this signal.

2.14.5 Development Serial Input (TDI/DSI)

The MTMOD signal determines the function of this dual-purpose pin. If MTMOD = 0, then TDI is selected. If MTMOD = 1, then DSI is selected. MTMOD should not change while $\overline{RSTI} = 1$.

The DSI input signal is the serial data input for the Debug module commands. See **Section 15: Debug Support** section for additional information on this signal.

2.14.6 Development Serial Output (TDO/DSO)

The MTMOD signal determines the function of this dual-purpose pin. When MTMOD = 0, TDO is selected. When MTMOD = 1, then DSO is selected. MTMOD should not change while $\overline{RSTI} = 1$.

The DSO output signal is the serial data output for the Debug module responses. See **Section 15: Debug Support** section for additional information on this signal.

2.15 JTAG SIGNALS

2.15.1 Test Clock (TCK)

TCK is the dedicated JTAG test logic clock that is independent of the MCF5206e processor clock. The internal JTAG controller logic is designed such that holding TCK high or low for an indefinite period of time will not cause the JTAG test logic to lose state information. TCK should be grounded if it is not used.

2.15.2 Test Reset (\overline{TRST} /DSCLK)

The MTMOD signal determines the function of this dual-purpose pin. If MTMOD = 0, the TRST function is selected. If MTMOD = 1, the DSCLK function is selected. MTMOD should not be changed while $\overline{RSTI} = 1$.

The assertion of the active-low \overline{TRST} input pin asynchronously resets the JTAG TAP controller to the test logic reset state, causing the JTAG instruction register to choose the “bypass” command. When this occurs, all the JTAG logic is benign and does not interfere with the normal functionality of the MCF5206e processor. Although this signal is asynchronous, we recommend that \overline{TRST} make only a 0 to 1 (asserted to negated) transition while TMS is held at a logic 1 value. \overline{TRST} has an internal pullup so that if it is

not driven low, its value will default to a logic level of 1. However, if JTAG is not used, TRST can either be tied to ground or, if TCK is clocked, it can be tied to VDD. The former connection places the JTAG controller in the test logic reset state immediately, while the latter connection causes the JTAG controller (if TMS is a logic 1) to eventually end up in the test logic reset state after five clocks of TCK.

2.15.3 Test Mode Select (TMS/BKPT)

The MTMOD signal determines the function of this dual-purpose pin. If MTMOD = 0, then the TMS function is selected. If MTMOD = 1, the BKPT function is selected. MTMOD should not change while $\overline{\text{RSTI}} = 1$.

The TMS input signal provides the JTAG controller with information to determine which test operation should be performed. The value of TMS and the current state of the internal 16-state JTAG controller state machine at the rising edge of TCK determine whether the JTAG controller holds its current state or advances to the next state. This directly controls whether JTAG data or instruction operations occur. TMS has an internal pullup so that if it is not driven low, its value will default to a logic level of 1. However, if TMS is not used, it should be tied to VDD.

2.15.4 Test Data Input (TDI/DSI)

The MTMOD signal determines the function of this dual-purpose pin. If MTMOD = 0, then TDI is selected. If MTMOD = 1, then DSI is selected. MTMOD should not change while $\overline{\text{RSTI}} = 1$.

The TDI input signal provides the serial data port for loading the various JTAG shift registers (the boundary scan register, the bypass register, and the instruction register). Shifting in of data depends on the state of the JTAG controller state machine and the instruction currently in the instruction register. This data shift occurs on the rising edge of TCK. TDI also has an internal pullup so that if it is not driven low, its value will default to a logic level of 1. However, if TDI will not be used, it should be tied to VDD.

2.15.5 Test Data Output (TDO/DSO)

The MTMOD signal determines the function of this dual-purpose pin. When MTMOD = 0, TDO is selected. When MTMOD = 1, then DSO is selected. MTMOD should not change while $\overline{\text{RSTI}} = 1$.

The TDO output signal provides the serial data port for outputting data from the JTAG logic. Shifting out of data depends on the state of the JTAG controller state machine and the instruction currently in the instruction register. This data shift occurs on the falling edge of TCK. When TDO is not outputting test data, it is placed in a high-impedance state. TDO can also be three-stated to allow bussed or parallel connections to other devices having JTAG.

2.16 TEST SIGNALS

2.16.1 Motorola Test Mode (MTMOD)

This input signal chooses between the debug and JTAG signals that are multiplexed together. When MTMOD=1, the MCF5206e is in Debug mode and when MTMOD=0, the MCF5206e is in JTAG mode.

2.16.2 High Impedance ($\overline{\text{HIZ}}$)

The assertion of the $\overline{\text{HIZ}}$ input signal forces all output drivers to a high-impedance state (three-state). The timing on $\overline{\text{HIZ}}$ is independent of the clock. Note that $\overline{\text{HIZ}}$ does not override JTAG operation; TDO/DSO can be forced to a high-impedance state by asserting $\overline{\text{TRST}}$.

If $\overline{\text{RSTI}}$ and $\overline{\text{HIZ}}$ are asserted simultaneously, the MCF5206e enters master reset mode. In this reset mode, the entire MCF5206e (including the DRAM controller refresh circuitry) is reset. You must use master reset for all power-on resets.

If $\overline{\text{RSTI}}$ is asserted while $\overline{\text{HIZ}}$ is negated, the MCF5206e enters normal reset mode. In this reset mode, the DRAM controller refresh circuitry is not reset and continues to generate refresh cycles at the programmed rate.

2.17 SIGNAL SUMMARY

Table 2-12 provides a summary of the electrical characteristics of the MCF5206e signals.

Table 2-12. MCF5206e Signal Summary

SIGNAL NAME	MNEMONIC	INPUT/OUTPUT	ACTIVE STATE	RESET STATE
Address[27:24]/Chip Select[7:4]/ Write Enable[0:3]	A[27:24]/ $\overline{\text{CS}}$ [7:4]/ $\overline{\text{WE}}$ [0:3]	In,Out/ Out/ Out	-/ Low/ Low	Three-stated/ Negated/ Negated
Address	A[23:0]	In,Out	-	Three-stated
Data	D[31:0]	In,Out	-	Three-stated
Chip Select[3:0]	$\overline{\text{CS}}$ [3:0]	Out	Low	Negated
Interrupt Priority Level/ Interrupt Request	$\overline{\text{IPL}}$ [2]/ $\overline{\text{IRQ}}$ [7] $\overline{\text{IPL}}$ [1]/ $\overline{\text{IRQ}}$ [4] $\overline{\text{IPL}}$ [0]/ $\overline{\text{IRQ}}$ [1]	In/In	Low	-
Read/Write	R/W	In,Out	-	Three-stated
Size	SIZ[1:0]	In,Out	-	Three-stated
Transfer Type	TT[1:0]	Out	-	Three-stated
Access Type & Mode	ATM	Out	-	Three-stated
Transfer Start	$\overline{\text{TS}}$	In,Out	Low	Three-stated
Transfer Acknowledge	$\overline{\text{TA}}$	In,Out	Low	Three-stated
Asynchronous Transfer Acknowledge	ATA	In	Low	-
Transfer Error Acknowledge	$\overline{\text{TEA}}$	In	Low	-
Bus Request	$\overline{\text{BR}}$	Out	Low	Negated
Bus Grant	$\overline{\text{BG}}$	In	Low	-

Table 2-12. MCF5206e Signal Summary (Continued)

SIGNAL NAME	MNEMONIC	INPUT/OUTPUT	ACTIVE STATE	RESET STATE
Bus Driven	BD	Out	Low	Negated
Clock Input	CLK	In	-	-
Reset	RSTI	In	Low	-
Row Address Strobe	RAS[1:0]	Out	Low	Master Reset - Negated Normal Reset - Unaffected
Column Address Strobe	CAS[3:0]	Out	Low	Master Reset - Negated Normal Reset - Unaffected
DRAM Write	DRAMW	Out	Low	Negated
Receive Data	RxD[1], RxD[2]	In	-	-
Transmit Data	TxD[1], TxD[2]	Out	-	Asserted
Request-To-Send	RTS[1]	Out	Low	Negated
Request-To-Send	RTS[2]/ RSTO	Out/ Out	Low/ Low	Asserted
Clear-To-Send	CTS[1], CTS[2]	In	Low	-
DMA Request Input	DREQ[0], DREQ[1]	In	-	-
Timer Input, DMA Request	TIN[1], DREQ[0]	In	-	-
Timer Input	TIN[2]	In	-	-
Timer Output, DMA Request	TOUT[1]/DREQ[0]	Out	-	-
Timer Output	TOUT[2]	Out	-	Asserted
Serial Clock Line	SCL	In,Out	Low	Negated
Serial Data Line	SDA	In,Out	Low	Negated
General Purpose I/O/ Processor Status	PP[7:4]/ PST[3:0]	In,Out/ Out	-/ -	Three-stated
General Purpose I/O/ Debug Data	PP[3:0]/ DDATA[3:0]	In,Out/ Out	-/ -	Three-stated
Test Clock	TCK	In	-	-
Test Data Output/Development Serial Output	TDO/ DSO	Out/ Out	-/ -	Three-States/ Negated
Test Mode Select/ Break Point	TMS/ BKPT	In/ In	-/ Low	-/ -
Test Data Input / Development Serial Input	TDI/ DSI	In/ In	-/ -	-/ -
Test Reset/Development Serial Clock	TRST/ DSCLK	In/ In	Low/ -	-/ -
Motorola Test Mode	MTMOD	In	-	-
High Impedance	HIZ	In	Low	-

SECTION 3 COLD FIRE CORE

This section describes the organization of the Version 2 (V2) ColdFire[®] 5200 processor core and an overview of the program-visible registers. For detailed information on instructions, see the *ColdFire Family Programmer's Reference Manual*.

3.1 PROCESSOR PIPELINES

Figure 3-1 is a block diagram showing the processor pipelines of a V2 ColdFire core.

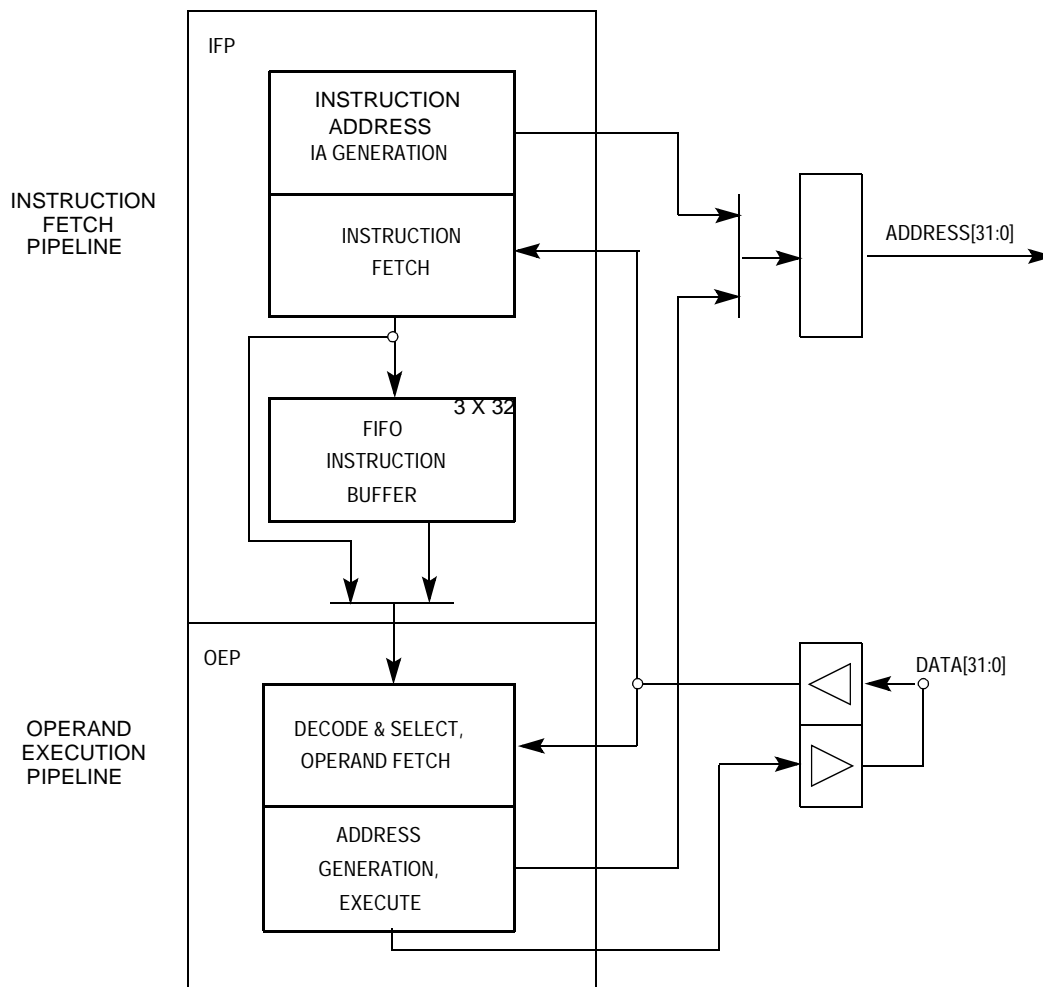

Figure 3-1. ColdFire Processor Core Pipelines

The processor core is comprised of two separate pipelines that are decoupled by an instruction buffer. The Instruction Fetch Pipeline (IFP) is responsible for instruction address generation and instruction fetch. The instruction buffer is a first-in-first-out (FIFO) buffer that holds prefetched instructions awaiting execution in the Operand Execution Pipeline (OEP). The OEP includes two pipeline stages. The first stage decodes instructions and selects operands (DSOC); the second stage (AGEX) performs instruction execution and calculates operand effective addresses, if needed.

3.2 PROCESSOR REGISTER DESCRIPTION

The following paragraphs describe the processor registers in the user and supervisor programming models. The appropriate programming model is selected based on the privilege level (user mode or supervisor mode) of the processor as defined by the S bit of the status register.

3.2.1 User Programming Model

Figure 3-2 illustrates the user programming model. The model is the same as for M68000 Family microprocessors, consisting of the following registers:

- 16 general-purpose 32-bit registers (D0–D7, A0–A7)
- 32-bit program counter (PC)
- 8-bit condition code register (CCR)

3.2.1.1 DATA REGISTERS (D0–D7). Registers D0–D7 are used as data registers for bit (1 bit), byte (8 bit), word (16 bit) and longword (32 bit) operations and can also be used as index registers.

3.2.1.2 ADDRESS REGISTERS (A0–A6). These registers can be used as software stack pointers, index registers, or base address registers as well as for word and longword operations.

3.2.1.3 STACK POINTER (A7). The ColdFire architecture supports a single hardware stack pointer (A7) for explicit references as well as for implicit ones during stacking for subroutine calls and returns and exception handling. The initial value of A7 is loaded from the reset exception vector, address \$0. The same register is used for both user and supervisor mode as well as word and longword operations.

A subroutine call saves the PC on the stack and the return restores it from the stack. Both the PC and the SR are saved on the stack during the processing of exceptions and interrupts. The return from exception instruction restores the SR and PC values from the stack.

3.2.1.4 PROGRAM COUNTER. The PC contains the address of the currently executing instruction. During instruction execution and exception processing, the processor automatically increments the contents of the PC or places a new value in the PC, as appropriate. For some addressing modes, the PC can be used as a pointer for PC-relative operand addressing.

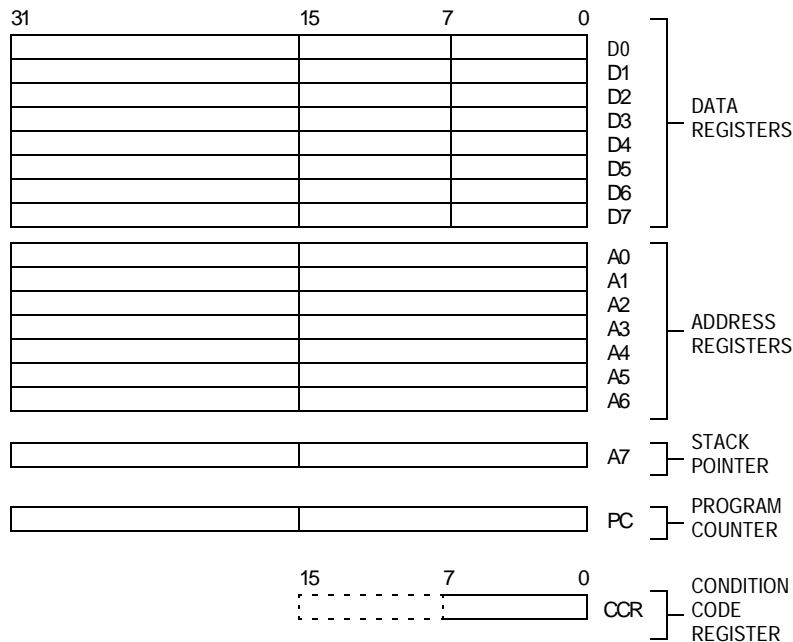
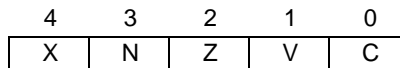

Figure 3-2. User Programming Model

3.2.1.5 CONDITION CODE REGISTER . The CCR is the least significant byte of the processor status register (SR). Bits 4–0 represent indicator flags based on results generated by processor operations. Bit 4, the extend bit (X bit), is also used as an input operand during multiprecision arithmetic computations.



X— extend condition code bit

N– negative condition code bit

Set if the most significant bit of the result is set; otherwise cleared

Z– zero condition code bit

Set if the result equals zero; otherwise cleared

V– overflow condition code bit

Set if an arithmetic overflow occurs implying that the result cannot be represented in the operand size; otherwise cleared

C– carry condition code bit

Set if a carryout of the operand MSB occurs for an addition, or if a borrow occurs in a subtraction; otherwise cleared

Set to the value of the C bit for arithmetic operations; otherwise not affected.

3.2.2 MAC Unit User Programming Model

The MAC portion of the user programming model available on the 5206e microprocessor core is shown below. It consists of the following registers:

- 32-bit accumulator (ACC)
- 16-bit mask register (MASK)
- 8-bit MAC status register (MACSR)

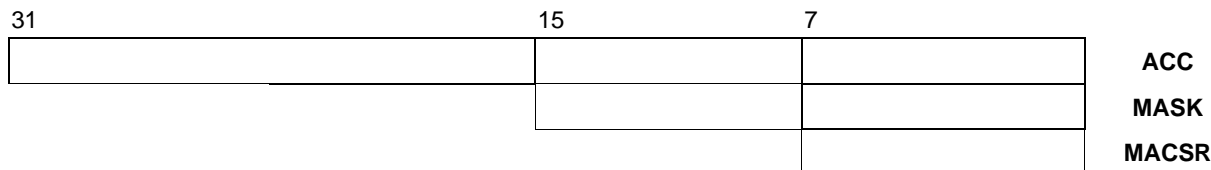

Figure 3-3. MAC Unit User Programming Model

3.2.3 Hardware Divide Module

The MCF5206e processor includes a hardware divider which performs a number of integer divide operations. The supported divide functions include: 32/16 producing a 16-bit quotient and 16-bit remainder, 32/32 producing a 32-bit quotient, and 32/32 producing 32-bit remainder.

3.2.4 Supervisor Programming Model

Only system programmers use the supervisor programming model to implement sensitive operating system functions, I/O control, and memory management. All accesses that affect the control features of ColdFire processors are in the supervisor programming model, which consists of the registers available to users as well as the following control registers:

- 16-bit status register (SR)
- 32-bit vector base register (VBR)

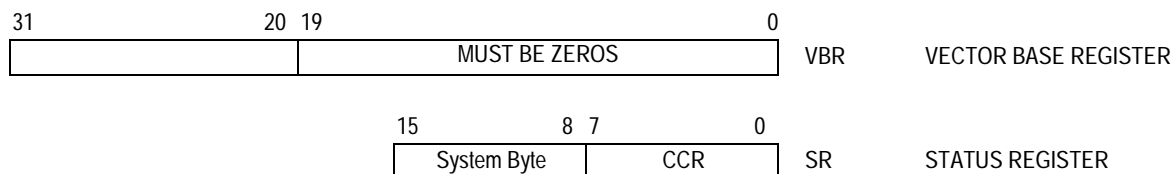

Figure 3-4. Supervisor Programming Model

Additional registers may be supported on a part-by-part basis.

The following paragraphs describe the supervisor programming model registers.

3.2.4.1 STATUS REGISTER. The SR stores the processor status and includes the CCR, the interrupt priority mask, and other control bits. In the supervisor mode, software can access the entire SR. In user mode, only the lower 8 bits are accessible (CCR). The control

bits indicate the following states for the processor: trace mode (T-bit), supervisor or user mode (S bit), and master or interrupt state (M).

SYSTEM BYTE						CONDITION CODE REGISTER (CCR)									
15	14	13	12	11	10	9	8	7	6	5	4	3	2	1	0
T	0	S	M	0	I[2:0]		0	0	0	X	N	Z	V	C	

Status Register

T– trace enable

When set, the processor will perform a trace exception after every instruction.

S– supervisor / user state

Denotes whether the processor is in supervisor mode (S=1) or user mode (S=0).

M– master / interrupt state

This bit is cleared by an interrupt exception, and can be set by software during execution of the RTE or move to SR instructions.

I[2:0]– interrupt priority mask

Defines the current interrupt priority. Interrupt requests are inhibited for all priority levels less than or equal to the current priority, except the edge-sensitive level 7 request, which cannot be masked.

3.2.4.2 VECTOR BASE REGISTER (VBR). The VBR contains the base address of the exception vector table in memory. The displacement of an exception vector is added to the value in this register to access the vector table. The lower 20 bits of the VBR are not implemented by ColdFire processors; they are assumed to be zero, forcing the table to be aligned on a 1 MByte boundary.

3.3 EXCEPTION PROCESSING OVERVIEW

Exception processing for ColdFire processors is streamlined for performance. The ColdFire processors provide a simplified exception processing model. The next section details the model. Differences from previous 68000 Family processors include:

- A simplified exception vector table
- Reduced relocation capabilities using the vector base register
- A single exception stack frame format
- Use of a single self-aligning system stack

ColdFire processors use an instruction restart exception model but do require more software support to recover from certain access errors. See subsection **3.5.1 Access Error Exception** for details.

Exception processing is comprised of four major steps and can be defined as the time from the detection of the fault condition until the fetch of the first handler instruction has been initiated.

First, the processor makes an internal copy of the SR and then enters supervisor mode by asserting the S bit and disabling trace mode by negating the T bit. The occurrence of an interrupt exception also forces the M bit to be cleared and the interrupt priority mask to be set to the level of the current interrupt request.

Second, the processor determines the exception vector number. For all faults *except* interrupts, the processor performs this calculation based on the exception type. For interrupts, the processor performs an interrupt-acknowledge (IACK) bus cycle to obtain the vector number from a peripheral device. The IACK cycle is mapped to a special acknowledge address space with the interrupt level encoded in the address.

Third, the processor saves the current context by creating an exception stack frame on the system stack. The V2 Core supports a single stack pointer in the A7 address register; therefore, there is no notion of separate supervisor or user stack pointers. As a result, the exception stack frame is created at a 0-modulo-4 address on the top of the current system stack. Additionally, the processor uses a simplified fixed-length stack frame for all exceptions. The exception type determines whether the program counter placed in the exception stack frame defines the location of the faulting instruction (fault) or the address of the next instruction to be executed (next).

Fourth, the processor calculates the address of the first instruction of the exception handler. By definition, the exception vector table is aligned on a 1 Mbyte boundary. This instruction address is generated by fetching an exception vector from the table located at the address defined in the vector base register. The index into the exception table is calculated as (4 x vector number). Once the exception vector has been fetched, the contents of the vector determine the address of the first instruction of the desired handler. After the instruction fetch for the first opcode of the handler has been initiated, exception processing terminates and normal instruction processing continues in the handler.

ColdFire 5200 processors support a 1024-byte vector table aligned on any 1 Mbyte address boundary (see Table 3-1). The table contains 256 exception vectors where the first 64 are defined by Motorola and the remaining 192 are user-defined interrupt vectors.

Table 3-1. Exception Vector Assignments

VECTOR NUMBER(S)	VECTOR OFFSET (HEX)	STACKED PROGRAM COUNTER	ASSIGNMENT
0	\$000	-	Initial stack pointer
1	\$004	-	Initial program counter
2	\$008	Fault	Access error
3	\$00C	Fault	Address error
4	\$010	Fault	Illegal instruction
5-7	\$014-\$01C	-	Reserved
8	\$020	Fault	Privilege violation
9	\$024	Next	Trace
10	\$028	Fault	Unimplemented line-a opcode
11	\$02C	Fault	Unimplemented line-f opcode
12	\$030	Next	Debug interrupt
13	\$034	-	Reserved
14	\$038	Fault	Format error
15	\$03C	Next	Uninitialized interrupt
16-23	\$040-\$05C	-	Reserved
24	\$060	Next	Spurious interrupt
25-31	\$064-\$07C	Next	Level 1-7 autovectored interrupts
32-47	\$080-\$0BC	Next	Trap # 0-15 instructions
48-63	\$0C0-\$0FC	-	Reserved
64-255	\$100-\$3FC	Next	User-defined interrupts

"Fault" refers to the PC of the instruction that caused the exception

"Next" refers to the PC of the next instruction that follows the instruction that caused the fault.

The V2 Core processors inhibit sampling for interrupts during the first instruction of all exception handlers. This allows any handler to effectively disable interrupts, if necessary, by raising the interrupt mask level contained in the status register.

3.4 EXCEPTION STACK FRAME DEFINITION

The exception stack frame is shown in Figure 3-5. The first longword of the exception stack frame contains the 16-bit format/vector word (F/V) and the 16-bit status register, and the second longword contains the 32-bit program counter address.

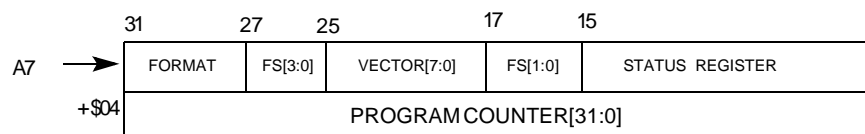

Figure 3-5. Exception Stack Frame Form

The 16-bit format/vector word contains 3 unique fields:

- A 4-bit format field at the top of the system stack is always written with a value of {4,5,6,7} by the processor indicating a two-longword frame format. See Table 3-2.

Table 3-2. Format Field Encodings

ORIGINAL A7 @ TIME OF EXCEPTION, BITS 1:0	A7 @ 1ST INSTRUCTION OF HANDLER	FORMAT FIELD
00	Original A7 - 8	4
01	Original A7 - 9	5
10	Original A7 - 10	6
11	Original A7 - 11	7

- There is a 4-bit fault status field, FS[3:0], at the top of the system stack. This field is defined for access and address errors only and written as zeros for all other types of exceptions. See Table 3-3.

Table 3-3. Fault Status Encodings

FS[3:0]	DEFINITION
00xx	Reserved
0100	Error on instruction fetch
0101	Reserved
011x	Reserved
1000	Error on operand write
1001	Attempted write to write-protected space
101x	Reserved
1100	Error on operand read
1101	Reserved
111x	Reserved

- The 8-bit vector number, vector[7:0], defines the exception type and is calculated by the processor for all internal faults and represents the value supplied by the peripheral in the case of an interrupt. Refer to Table 3-1.

3.5 PROCESSOR EXCEPTIONS

3.5.1 Access Error Exception

The exact processor response to an access error depends on the type of memory reference being performed. For an instruction fetch, the processor postpones the error reporting until the faulted reference is needed by an instruction for execution. Therefore, faults that occur during instruction prefetches that are then followed by a change of instruction flow do not generate an exception. When the processor attempts to execute an instruction with a faulted opword and/or extension words, the access error is signaled and the instruction aborted. For this type of exception, the programming model has not been altered by the instruction generating the access error.

If the access error occurs on an operand read, the processor immediately aborts the current instruction's execution and initiates exception processing. In this situation, any address

register updates attributable to the auto-addressing modes, (e.g., (An)+, -(An)), have already been performed, so the programming model contains the updated An value. In addition, if an access error occurs during the execution of a MOVEM instruction loading from memory, any registers already updated *before* the fault occurs contains the operands from memory.

The ColdFire processor uses an imprecise reporting mechanism for access errors on operand writes. Because the actual write cycle may be decoupled from the processor's issuing of the operation, the signaling of an access error appears to be decoupled from the instruction that generated the write. Accordingly, the PC contained in the exception stack frame merely represents the location in the program when the access error was signaled. All programming model updates associated with the write instruction are completed. The NOP instruction can collect access errors for writes. This instruction delays its execution until all previous operations, including all pending write operations, are complete. If any previous write terminates with an access error, it is guaranteed to be reported on the NOP instruction.

3.5.2 Address Error Exception

Any attempted execution transferring control to an odd instruction address (i.e., if bit 0 of the target address is set) results in an address error exception.

Any attempted use of a word-sized index register (Xn.w) or a scale factor of 8 on an indexed effective addressing mode generates an address error as does an attempted execution of a full-format indexed addressing mode.

3.5.3 Illegal Instruction Exception

Any attempted execution of the \$0000 and the \$4AFC opcodes generates an illegal instruction exception. Additionally, any attempted execution of any non-MAC line A and most line F opcode generates their unique exception types, vector numbers 10 and 11, respectively. The MCF5206e does not provide illegal instruction detection on the extension words on any instruction, including MOVEC. If any other nonsupported opcode is executed, the resulting operation is undefined.

3.5.4 Privilege Violation

The attempted execution of a supervisor mode instruction while in user mode generates a privilege violation exception. See the *ColdFire Programmer's Reference Manual* for lists of supervisor- and user-mode instructions.

3.5.5 Trace Exception

To aid in program development, the V2 processors provide an instruction-by-instruction tracing capability. While in trace mode, indicated by the assertion of the T bit in the status register (SR[15] = 1), the completion of an instruction execution signals a trace exception. This functionality allows a debugger to monitor program execution.

The single exception to this definition is the STOP instruction. When the STOP opcode is executed, the processor core waits until an unmasked interrupt request is asserted, then aborts the pipeline and initiates interrupt exception processing.

Because ColdFire processors do not support any hardware stacking of multiple exceptions, it is the responsibility of the operating system to check for trace mode after processing other exception types. As an example, consider the execution of a TRAP instruction while in trace mode. The processor will initiate the TRAP exception and then pass control to the corresponding handler. If the system requires that a trace exception be processed, it is the responsibility of the TRAP exception handler to check for this condition (SR[15] in the exception stack frame asserted) and pass control to the trace handler before returning from the original exception.

3.5.6 Debug Interrupt

This special type of program interrupt is discussed in detail in **Section 15: Debug support**. This exception is generated in response to a hardware breakpoint register trigger. The processor does not generate an IACK cycle but rather calculates the vector number internally (vector number 12).

3.5.7 RTE and Format Error Exceptions

When an RTE instruction is executed, the processor first examines the 4-bit format field to validate the frame type. For a ColdFire 5200 processor, any attempted execution of an RTE where the format is not equal to {4,5,6,7} generates a format error. The exception stack frame for the format error is created without disturbing the original RTE frame and the stacked PC pointing to the RTE instruction.

The selection of the format value provides some limited debug support for porting code from 68000 applications. On 680x0 Family processors, the SR was located at the top of the stack. On those processors, bit[30] of the longword addressed by the system stack pointer is typically zero. Thus, if an RTE is attempted using this “old” format, it generates a format error on a ColdFire 5200 processor.

If the format field defines a valid type, the processor: (1) reloads the SR operand, (2) fetches the second longword operand, (3) adjusts the stack pointer by adding the format value to the auto-incremented address after the fetch of the first longword, and then (4) transfers control to the instruction address defined by the second longword operand within the stack frame.

3.5.8 TRAP Instruction Exceptions

The TRAP #n instruction always forces an exception as part of its execution and is useful for implementing system calls.

3.5.9 Interrupt Exception

The interrupt exception processing, with interrupt recognition and vector fetching, includes uninitialized and spurious interrupts as well as those where the requesting device supplies the 8-bit interrupt vector. Autovectoring may optionally be supported through the System Integration module (SIM). Refer to **Section 8: System Integration Module** to see if this is supported on the MCF5206e.

3.5.10 Fault-on-Fault Halt

If a V2 processor encounters any type of fault during the exception processing of another fault, the processor immediately halts execution with the catastrophic “fault-on-fault” condition. A reset is required to force the processor to exit this halted state.

3.5.11 Reset Exception

Asserting the reset input signal to the processor causes a reset exception. The reset exception has the highest priority of any exception; it provides for system initialization and recovery from catastrophic failure. Reset also aborts any processing in progress when the reset input is recognized. Processing cannot be recovered.

The reset exception places the processor in the supervisor mode by setting the S bit and disables tracing by clearing the T bit in the SR. This exception also clears the M bit and sets the processor’s interrupt priority mask in the SR to the highest level (level 7). Next, the VBR is initialized to zero (\$00000000). The control registers specifying the operation of any memories (e.g., cache and/or RAM modules) connected directly to the processor are disabled.

Note

Other implementation-specific supervisor registers are also affected. Refer to each of the modules in this user’s manual for details on these registers.

Once the processor is granted the bus and it does not detect any other alternate masters taking the bus, the core then performs two longword read bus cycles. The first longword at address 0 is loaded into the stack pointer and the second longword at address 4 is loaded into the program counter. After the initial instruction is fetched from memory, program execution begins at the address in the PC. If an access error or address error occurs before the first instruction is executed, the processor enters the fault-on-fault halted state.

3.6 INSTRUCTION EXECUTION TIMING

This section presents V2 processor instruction execution times in terms of processor core clock cycles. The number of operand references for each instruction is enclosed in parentheses following the number of clock cycles. Each timing entry is presented as **C(r/w)** where:

- **C** - number of processor clock cycles, including all applicable operand fetches and writes, and all internal core cycles required to complete the instruction execution.
- **r/w** - number of operand reads (r) and writes (w) required by the instruction. An operation performing a read-modify-write function is denoted as (1/1).

This section includes the assumptions concerning the timing values and the execution time details.

3.6.1 Timing Assumptions

For the timing data presented in this section, the following assumptions apply:

1. The operand execution pipeline (OEP) is loaded with the opword and all required ex-

rs(o)93(ur)jO boeoc(o)93(meo)93((s))93(v)3831awi543((l543(ab(l543(eo)93(.d)1.3(Thuo)93(()3

Table 3-5. Move Byte and Word Execution Times

SOURCE	DESTINATION						
	RX	(AX)	(AX)+	-(AX)	(D ₁₆ ,AX)	(D ₈ ,AX,XI)	(XXX).WL
Dn	1(0/0)	1(0/1)	1(0/1)	1(0/1)	1(0/1)	2(0/1)	1(0/1)
An	1(0/0)	1(0/1)	1(0/1)	1(0/1)	1(0/1)	2(0/1)	1(0/1)
(An)	3(1/0)	3(1/1)	3(1/1)	3(1/1)	3(1/1)	4(1/1)	3(1/1)
(An)+	3(1/0)	3(1/1)	3(1/1)	3(1/1)	3(1/1)	4(1/1)	3(1/1)
-(An)	3(1/0)	3(1/1)	3(1/1)	3(1/1)	3(1/1)	4(1/1)	3(1/1)
(d ₁₆ ,An)	3(1/0)	3(1/1)	3(1/1)	3(1/1)	3(1/1)	—	—
(d ₈ ,An,XI)	4(1/0)	4(1/1)	4(1/1)	4(1/1)	—	—	—
(xxx).w	3(1/0)	3(1/1)	3(1/1)	3(1/1)	—	—	—
(xxx).l	3(1/0)	3(1/1)	3(1/1)	3(1/1)	—	—	—
(d ₁₆ ,PC)	3(1/0)	3(1/1)	3(1/1)	3(1/1)	3(1/1)	—	—
(d ₈ ,PC,XI)	4(1/0)	4(1/1)	4(1/1)	4(1/1)	—	—	—
#<xxx>	1(0/0)	3(0/1)	3(0/1)	3(0/1)	—	—	—

Table 3-6. Move Long Execution Times

SOURCE	DESTINATION						
	RX	(AX)	(AX)+	-(AX)	(D ₁₆ ,AX)	(D ₈ ,AX,XI)	(XXX).WL
Dn	1(0/0)	1(0/1)	1(0/1)	1(0/1)	1(0/1)	2(0/1)	1(0/1)
An	1(0/0)	1(0/1)	1(0/1)	1(0/1)	1(0/1)	2(0/1)	1(0/1)
(An)	2(1/0)	2(1/1)	2(1/1)	2(1/1)	2(1/1)	3(1/1)	2(1/1)
(An)+	2(1/0)	2(1/1)	2(1/1)	2(1/1)	2(1/1)	3(1/1)	2(1/1)
-(An)	2(1/0)	2(1/1)	2(1/1)	2(1/1)	2(1/1)	3(1/1)	2(1/1)
(d ₁₆ ,An)	2(1/0)	2(1/1)	2(1/1)	2(1/1)	2(1/1)	—	—
(d ₈ ,An,XI)	3(1/0)	3(1/1)	3(1/1)	3(1/1)	—	—	—
(xxx).w	2(1/0)	2(1/1)	2(1/1)	2(1/1)	—	—	—
(xxx).l	2(1/0)	2(1/1)	2(1/1)	2(1/1)	—	—	—
(d ₁₆ ,PC)	2(1/0)	2(1/1)	2(1/1)	2(1/1)	2(1/1)	—	—
(d ₈ ,PC,XI)	3(1/0)	3(1/1)	3(1/1)	3(1/1)	—	—	—
#<xxx>	1(0/0)	2(0/1)	2(0/1)	2(0/1)	—	—	—

3.7 STANDARD ONE OPERAND INSTRUCTION EXECUTION TIMES

Table 3-7. One Operand Instruction Execution Times

OPCODE	<EA>	EFFECTIVE ADDRESS							
		RN	(AN)	(AN)+	-(AN)	(D16,AN)	(D8,AN,XN*SF)	XXX.WL	#XXX
CLR.B	<ea>	1(0/0)	1(0/1)	1(0/1)	1(0/1)	1(0/1)	2(0/1)	1(0/1)	—
CLR.W	<ea>	1(0/0)	1(0/1)	1(0/1)	1(0/1)	1(0/1)	2(0/1)	1(0/1)	—
CLR.L	<ea>	1(0/0)	1(0/1)	1(0/1)	1(0/1)	1(0/1)	2(0/1)	1(0/1)	—
EXT.W	Dx	1(0/0)	—	—	—	—	—	—	—
EXT.L	Dx	1(0/0)	—	—	—	—	—	—	—
EXTB.L	Dx	1(0/0)	—	—	—	—	—	—	—
NEG.L	Dx	1(0/0)	—	—	—	—	—	—	—
NEGX.L	Dx	1(0/0)	—	—	—	—	—	—	—
NOT.L	Dx	1(0/0)	—	—	—	—	—	—	—
ScC	Dx	1(0/0)	—	—	—	—	—	—	—
SWAP	Dx	1(0/0)	—	—	—	—	—	—	—
TST.B	<ea>	1(0/0)	3(1/0)	3(1/0)	3(1/0)	3(1/0)	4(1/0)	3(1/0)	1(0/0)
TST.W	<ea>	1(0/0)	3(1/0)	3(1/0)	3(1/0)	3(1/0)	4(1/0)	3(1/0)	1(0/0)
TST.L	<ea>	1(0/0)	2(1/0)	2(1/0)	2(1/0)	2(1/0)	3(1/0)	2(1/0)	1(0/0)

3.8 STANDARD TWO OPERAND INSTRUCTION EXECUTION TIMES

Table 3-8. Two Operand Instruction Execution Times

OPCODE	<EA>	EFFECTIVE ADDRESS							
		RN	(AN)	(AN)+	-(AN)	(D16,AN) (D16,PC)	(D8,AN,XN*SF) (D8,PC,XN*SF)	XXX.WL	#XXX
ADD.L	<ea>,Rx	1(0/0)	3(1/0)	3(1/0)	3(1/0)	3(1/0)	4(1/0)	3(1/0)	1(0/0)
ADD.L	Dy,<ea>	—	3(1/1)	3(1/1)	3(1/1)	3(1/1)	4(1/1)	3(1/1)	—
ADDI.L	#imm,Dx	1(0/0)	—	—	—	—	—	—	—
ADDQ.L	#imm,<ea>	1(0/0)	3(1/1)	3(1/1)	3(1/1)	3(1/1)	4(1/1)	3(1/1)	—
ADDX.L	Dy,Dx	1(0/0)	—	—	—	—	—	—	—
AND.L	<ea>,Rx	1(0/0)	3(1/0)	3(1/0)	3(1/0)	3(1/0)	4(1/0)	3(1/0)	1(0/0)
AND.L	Dy,<ea>	—	3(1/1)	3(1/1)	3(1/1)	3(1/1)	4(1/1)	3(1/1)	—
ANDI.L	#imm,Dx	1(0/0)	—	—	—	—	—	—	—
ASL.L	<ea>,Dx	1(0/0)	—	—	—	—	—	—	1(0/0)
ASR.L	<ea>,Dx	1(0/0)	—	—	—	—	—	—	1(0/0)
BCHG	Dy,<ea>	2(0/0)	4(1/1)	4(1/1)	4(1/1)	4(1/1)	5(1/1)	4(1/1)	—
BCHG	#imm,<ea>	2(0/0)	4(1/1)	4(1/1)	4(1/1)	4(1/1)	—	—	—
BCLR	Dy,<ea>	2(0/0)	4(1/1)	4(1/1)	4(1/1)	4(1/1)	5(1/1)	4(1/1)	—
BCLR	#imm,<ea>	2(0/0)	4(1/1)	4(1/1)	4(1/1)	4(1/1)	—	—	—
BSET	Dy,<ea>	2(0/0)	4(1/1)	4(1/1)	4(1/1)	4(1/1)	5(1/1)	4(1/1)	—
BSET	#imm,<ea>	2(0/0)	4(1/1)	4(1/1)	4(1/1)	4(1/1)	—	—	—
BTST	Dy,<ea>	2(0/0)	3(1/1)	3(1/1)	3(1/1)	3(1/1)	4(1/1)	3(1/1)	—
BTST	#imm,<ea>	1(0/0)	3(1/1)	3(1/1)	3(1/1)	3(1/1)	—	—	1(0/0)
CMP.L	<ea>,Rx	1(0/0)	3(1/0)	3(1/0)	3(1/0)	3(1/0)	4(1/0)	3(1/0)	1(0/0)
CMPI.L	#imm,Dx	1(0/0)	—	—	—	—	—	—	—
DIVS.W	<ea>,Dx	20(0/0)	23(1/0)	23(1/0)	23(1/0)	23(1/0)	24(1/0)	23(1/0)	20(0/0)
DIVU.W	<ea>,Dx	20(0/0)	23(1/0)	23(1/0)	23(1/0)	23(1/0)	24(1/0)	23(1/0)	20(0/0)
DIVS.L	<ea>,Dx	35(0/0)	35(1/0)	35(1/0)	35(1/0)	35(1/0)			
DIVU.L	<ea>,Dx	35(0/0)	35(1/0)	35(1/0)	35(1/0)	35(1/0)			
EOR.L	Dy,<ea>	1(0/0)	3(1/1)	3(1/1)	3(1/1)	3(1/1)	4(1/1)	3(1/1)	—
EORI.L	#imm,Dx	1(0/0)	—	—	—	—	—	—	—
LEA	<ea>,Ax	—	1(0/0)	—	—	1(0/0)	2(0/0)	1(0/0)	—
LSL.L	<ea>,Dx	1(0/0)	—	—	—	—	—	—	1(0/0)
LSR.L	<ea>,Dx	1(0/0)	—	—	—	—	—	—	1(0/0)
MAC.W	Ry,Rx	1(0/0)	—	—	—	—	—	—	—
MAC.L	Ry,Rx	3(0/0)	—	—	—	—	—	—	—
MSAC.W	Ry,Rx	1(0/0)	—	—	—	—	—	—	—
MSAC.L	Ry,Rx	3(0/0)	—	—	—	—	—	—	—
MAC.W	Ry,Rx,ea,Rw	—	3(1/0)	3(1/0)	3(1/0)	3(1/0)	—	—	—
MAC.L	Ry,Rx,ea,Rw	—	5(1/0)	5(1/0)	5(1/0)	5(1/0)	—	—	—
MSAC.W	Ry,Rx,ea,Rw	—	3(1/0)	3(1/0)	3(1/0)	3(1/0)	—	—	—
MSAC.L	Ry,Rx,ea,Rw	—	5(1/0)	5(1/0)	5(1/0)	5(1/0)	—	—	—
MOVEQ	#imm,Dx	—	—	—	—	—	—	—	1(0/0)
MULS.W	<ea>,Dx	9(0/0)	11(1/0)	11(1/0)	11(1/0)	11(1/0)	12(1/0)	11(1/0)	9(0/0)
MULU.W	<ea>,Dx	9(0/0)	11(1/0)	11(1/0)	11(1/0)	11(1/0)	12(1/0)	11(1/0)	9(0/0)
MULS.L ¹	<ea>,Dx	£ 18(0/0)	£ 20(1/0)	£ 20(1/0)	£ 20(1/0)	£ 20(1/0)	—	—	—
MULU.L ¹	<ea>,Dx	£ 18(0/0)	£ 20(1/0)	£ 20(1/0)	£ 20(1/0)	£ 20(1/0)	—	—	—
OR.L	<ea>,Rx	1(0/0)	3(1/0)	3(1/0)	3(1/0)	3(1/0)	4(1/0)	3(1/0)	1(0/0)
OR.L	Dy,<ea>	—	3(1/1)	3(1/1)	3(1/1)	3(1/1)	4(1/1)	3(1/1)	—

Table 3-8. Two Operand Instruction Execution Times

OPCODE	<EA>	EFFECTIVE ADDRESS							
		RN	(AN)	(AN)+	-(AN)	(D16,AN) (D16,PC)	(D8,AN,XN*SF) (D8,PC,XN*SF)	XXX.WL	#XXX
ORI.L	#imm,Dx	1(0/0)	—	—	—	—	—	—	—
SUB.L	<ea>,Rx	1(0/0)	3(1/0)	3(1/0)	3(1/0)	3(1/0)	4(1/0)	3(1/0)	1(0/0)
SUB.L	Dy,<ea>	—	3(1/1)	3(1/1)	3(1/1)	3(1/1)	4(1/1)	3(1/1)	—
SUBI.L	#imm,Dx	1(0/0)	—	—	—	—	—	—	—
SUBQ.L	#imm,<ea>	1(0/0)	3(1/1)	3(1/1)	3(1/1)	3(1/1)	4(1/1)	3(1/1)	—
SUBX.L	Dy,Dx	1(0/0)	—	—	—	—	—	—	—

3.9 MISCELLANEOUS INSTRUCTION EXECUTION TIMES

Table 3-9. Miscellaneous Instruction Execution Times

OPCODE	<EA>	EFFECTIVE ADDRESS							
		RN	(AN)	(AN)+	-(AN)	(D16,AN)	(D8,AN,Xn*SF)	XXX.WL	#XXX
LINK.W	Ay,#imm	2(0/1)	—	—	—	—	—	—	—
MOVE.W	CCR,Dx	1(0/0)	—	—	—	—	—	—	—
MOVE.W	<ea>,CCR	1(0/0)	—	—	—	—	—	—	1(0/0)
MOVE.W	SR,Dx	1(0/0)	—	—	—	—	—	—	—
MOVE.W	<ea>,SR	7(0/0)	—	—	—	—	—	—	7(0/0) ²
MOVEC	Ry,Rc	9(0/1)	—	—	—	—	—	—	—
MOVEM.L	<ea>,&list	—	1+n(n/0)	—	—	1+n(n/0)	—	—	—
MOVEM.L	&list,<ea>	—	1+n(0/n)	—	—	1+n(0/n)	—	—	—
NOP		3(0/0)	—	—	—	—	—	—	—
PEA	<ea>	—	2(0/1)	—	—	2(0/1) ⁴	3(0/1) ⁵	2(0/1)	—
PULSE		1(0/0)	—	—	—	—	—	—	—
STOP	#imm	—	—	—	—	—	—	—	3(0/0) ³
TRAP	#imm	—	—	—	—	—	—	—	15(1/2)
TRAPF		1(0/0)	—	—	—	—	—	—	—
TRAPF.W		1(0/0)	—	—	—	—	—	—	—
TRAPF.L		1(0/0)	—	—	—	—	—	—	—
UNLK	Ax	2(1/0)	—	—	—	—	—	—	—
WDDATA	<ea>	—	3(1/0)	3(1/0)	3(1/0)	3(1/0)	4(1/0)	3(1/0)	3(1/0)
WDEBUG	<ea>	—	5(2/0)	—	—	5(2/0)	—	—	—

n is the number of registers moved by the MOVEM opcode.
¹E indicates that long multiplies have early termination after 9 cycles; thus, actual cycle count is operand independent
²If a MOVE.W #imm,SR instruction is executed and imm[13] = 1, the execution time is 1(0/0).
³The execution time for STOP is the time required until the processor begins sampling continuously for interrupts.
⁴PEA execution times are the same for (d16,PC)
⁵PEA execution times are the same for (d8,PC,Xn*SF)

3.10 BRANCH INSTRUCTION EXECUTION TIMES

Table 3-10. General Branch Instruction Execution Times

OPCODE	<EA>	EFFECTIVE ADDRESS							
		RN	(AN)	(AN)+	-(AN)	(D16,AN) (D16,PC)	(D8,AN,XI*SF) (D8,PC,XI*SF)	XXX.WL	#XXX
BSR		—	—	—	—	3(0/1)	—	—	—
JMP	<ea>	—	3(0/0)	—	—	3(0/0)	4(0/0)	3(0/0)	—
JSR	<ea>	—	3(0/1)	—	—	3(0/1)	4(0/1)	3(0/1)	—
RTE		—	—	10(2/0)	—	—	—	—	—
RTS		—	—	5(1/0)	—	—	—	—	—

Table 3-11. BRA, Bcc Instruction Execution Times

OPCODE	FORWARD TAKEN	FORWARD NOT TAKEN	BACKWARD TAKEN	BACKWARD NOT TAKEN
BRA	2(0/0)	—	2(0/0)	—
Bcc	3(0/0)	1(0/0)	2(0/0)	3(0/0)

SECTION 4 INSTRUCTION CACHE

4.1 FEATURES OF INSTRUCTION CACHE

- 4 KByte Direct-Mapped Cache
- Single-Cycle Access on Cache Hits
- Physically Located on ColdFire[®] Core's High-Speed Local Bus
- Nonblocking Design to Maximize Performance
- 16 Byte Line-Fill Buffer
- Configurable Cache Miss-Fetch Algorithm

4.2 INSTRUCTION CACHE PHYSICAL ORGANIZATION

The instruction cache is a direct-mapped single-cycle memory, organized as 256 lines, each containing 16 Bytes. The memory storage consists of a 256-entry tag array (containing addresses and a valid bit), and the data array containing 4 KBytes of instruction data, organized as 1024 x 32 bits.

The two memory arrays are accessed in parallel: bits [11:4] of the instruction fetch address provide the index into the tag array, and bits [11:2] addressing the data array. The tag array outputs the address mapped to the given cache location along with the valid bit for the line. This address field is compared to bits [31:12] of the instruction fetch address from the local bus to determine if a cache hit in the memory array has occurred. If the desired address is mapped into the cache memory, the output of the data array is driven onto the ColdFire core's local data bus completing the access in a single cycle.

The tag array maintains a single valid bit per line entry. Accordingly, only entire 16 Byte lines are loaded into the instruction cache.

The instruction cache also contains a 16 Byte fill buffer that provides temporary storage for the last line fetched in response to a cache miss. With each instruction fetch, the contents of the line fill buffer are examined. Thus, each instruction fetch address examines both the tag memory array and the line fill buffer to see if the desired address is mapped into either hardware resource. A cache hit in either the memory array or the line-fill buffer is serviced in a single cycle. Because the line fill buffer maintains valid bits on a longword basis, hits in the buffer can be serviced immediately without waiting for the entire line to be fetched.

If the referenced address is not contained in the memory array or the line-fill buffer, the instruction cache initiates the required external fetch operation. In most situations, this is a 16-byte line-sized burst reference.

4.3.1 Interaction With Other Modules

Because both the instruction cache and high-speed SRAM module are connected to the ColdFire core's local data bus, certain user-defined configurations can result in simultaneous instruction fetch processing.

If the referenced address is mapped into the SRAM module, that module will service the request in a single cycle. In this case, data accessed from the instruction cache is simply discarded and no external memory references are generated. If the address is not mapped into the SRAM space, the instruction cache handles the request in the normal fashion.

4.3.2 Memory Reference Attributes

For every memory reference the ColdFire core or the debug module generates, a set of "effective attributes" is determined based on the address and the Access Control Registers (ACR0, ACR1). This set of attributes includes the cacheable/noncacheable definition, the precise/imprecise handling of operand write, and the write-protect capability.

In particular, each address is compared to the values programmed in the Access Control Registers (ACR). If the address matches one of the ACR values, the access attributes from that ACR are applied to the reference. If the address does not match either ACR, then the default value defined in the Cache Control Register (CACR) is used. The specific algorithm is as follows:

```
if (address = ACR0_address including mask)
    Effective Attributes = ACR0 attributes
else if (address = ACR1_address including mask)
    Effective Attributes = ACR1 attributes
else Effective Attributes = CACR default attributes
```

4.3.3 Cache Coherency and Invalidation

The instruction cache does not monitor ColdFire core data references for accesses to cached instructions. Therefore, software must maintain cache coherency by invalidating the appropriate cache entries after modifying code segments.

The cache invalidation can be performed in two ways. The assertion of bit 24 in the CACR forces the entire instruction cache to be marked as invalid. The invalidation operation requires 256 cycles because the cache sequences through the entire tag array, clearing a single location each cycle. Any subsequent instruction fetch accesses are postponed until the invalidation sequence is complete.

The privileged CPUSHL instruction can invalidate a single cache line. When this instruction is executed, the cache entry defined by bits[11:4] of the source address register is invalidated, provided bit 28 of the CACR is cleared.

These invalidation operations can be initiated from the ColdFire core or the debug module.

4.3.4 RESET

A hardware reset clears the CACR disabling the instruction cache. The contents of the tag array are not affected by the reset. Accordingly, the system startup code must explicitly perform a cache invalidation by setting CACR[24] before the cache can be enabled.

4.3.5 Cache Miss Fetch Algorithm/Line Fills

As discussed in **Section 4.2 Instruction Cache Physical Organization**, the instruction cache hardware includes a 16-byte line fill buffer for providing temporary storage for the last fetched instruction.

With the cache enabled as defined by CACR[31], a cacheable instruction fetch that misses in both the tag memory and the line-fill buffer generates an external fetch. The size of the external fetch is determined by the value contained in the 2-bit CLNF field of the CACR and the miss address. Table 4-1 shows the relationship between the CLNF bits, the miss address, and the size of the external fetch.

Table 4-1. Initial Fetch Offset vs. CLNF Bits

CLNF[1:0]	LONGWORD ADDRESS BITS			
	00	01	10	11
00	Line	Line	Line	Longword
01	Line	Line	Longword	Longword
1X	Line	Line	Line	Line

Depending on the runtime characteristics of the application and the memory response speed, overall performance may be increased by programming the CLNF bits to values {00, 01}.

For all cases of a line-sized fetch, the critical longword defined by bits [3:2] of the miss address is accessed first followed by the remaining three longwords that are accessed by incrementing the longword address in a modulo-16 fashion as shown below:

```

if miss address[3:2] = 00
    fetch sequence = {$0, $4, $8, $C}
if miss address[3:2] = 01
    fetch sequence = {$4, $8, $C, $0}
if miss address[3:2] = 10
    fetch sequence = {$8, $C, $0, $4}
if miss address[3:2] = 11
    fetch sequence = {$C, $0, $4, $8}

```

Once an external fetch has been initiated and the data loaded into the line-fill buffer, the instruction cache maintains a special “most-recently-used” indicator that tracks the

contents of the fill buffer versus its corresponding cache location. At the time of the miss, the hardware indicator is set, marking the fill buffer as “most recently used.” If a subsequent access occurs to the cache location defined by bits [8:4] of the fill buffer address, the data in the cache memory array is now most recently used, so the hardware indicator is cleared. In all cases, the indicator defines whether the contents of the line fill buffer or the memory data array are most recently used. At the time of the next cache miss, the contents of the line-fill buffer are written into the memory array if the entire line is present, and the fill buffer data is still most recently used compared to the memory array.

The fill buffer can also be used as temporary storage for line-sized bursts of non-cacheable references under control of CACR[10]. With this bit set, a noncacheable instruction fetch is processed as defined by Table 4-2. For this condition, the fill buffer is loaded and subsequent references can hit in the buffer, but the data is never loaded into the memory array.

Table 4-2 shows the relationship between CACR bits 31 and 10 and the type of instruction fetch.

Table 4-2. Instruction Cache Operation as Defined by CACR[31,10]

CACR[31]	CACR[10]	TYPE OF INSTR. FETCH	DESCRIPTION
0	0	N/A	Instruction cache is completely disabled; all fetches are word, longword in size.
0	1	N/A	All fetches are word, longword in size
1	X	Cacheable	Fetch size is defined by Table 4-1 and contents of the line-fill buffer can be written into the memory array
1	0	Noncacheable	All fetches are longword in size, and not loaded into the line-fill buffer
1	1	Noncacheable	Fetch size is defined by Table 4-1 and loaded into the line-fill buffer, but are never written into the memory array.

4.4 INSTRUCTION CACHE PROGRAMMING MODEL

Three supervisor registers define the operation of the instruction cache and local bus controller: the Cache Control Register (CACR) and two Access Control Registers (ACR0, ACR1).

4.4.1 Instruction Cache Registers Memory Map

Table 4-3 below shows the memory map of the Instruction cache and access control registers.

The following lists several keynotes regarding the programming model table:

- The Cache Control Register and Access Control Registers can only be accessed in supervisor mode using the MOVEC instruction with an Rc value of \$002, \$004 and \$005, respectively.

- Addresses not assigned to the registers and undefined register bits are reserved for future expansion. Write accesses to these reserved address spaces and reserved register bits have no effect; read accesses will return zeros.
- The reset value column indicates the initial value of the register at reset. Certain registers may be uninitialized upon reset, i.e., they may contain random values after reset.
- The access column indicates if the corresponding register allows both read/write functionality (R/W), read-only functionality (R), or write-only functionality (W). If a read access to a write-only register is attempted, zeros will be returned. If a write access to a read-only register is attempted the access will be ignored and no write will occur.

Table 4-3. Memory Map of I-Cache Registers

ADDRESS	NAME	WIDTH	DESCRIPTION	RESET VALUE	ACCESS
MOVEC with \$002	CACR	32	Cache Control Register	\$0000	W
MOVEC with \$004	ACR0	32	Access Control Register 0	\$0000	W
MOVEC with \$005	ACR1	32	Access Control Register 1	\$0000	W

4.4.2 Instruction Cache Register

4.4.2.1 CACHE CONTROL REGISTER (CACR). The CACR controls the operation of the instruction cache. The CACR provides a set of default memory access attributes used when a reference address does not map into the spaces defined by the ACRs.

The CACR is a 32-bit write-only supervisor control register. It is accessed in the CPU address space via the MOVEC instruction with an Rc encoding of \$002. The CACR can be read when in Background Debug mode (BDM). At system reset, the entire register is cleared.

Cache Control Register (CACR)

31	30	29	28	27	26	25	24	23	22	21	20	19	18	17	16
CENB	-	-	CPDI	CFRZ	-	-	CINV	-	-	-	-	-	-	-	-
RESET:	0	0	0	0	0	0	0	0	0	0	0	0	0	0	0
15	14	13	12	11	10	9	8	7	6	5	4	3	2	1	0
-	-	-	-	-	CEIB	DCM	DBWE	-	-	DWP	-	-	-	CLNF1	
RESET:	0	0	0	0	0	0	0	0	0	0	0	0	0	0	0

CENB - Cache Enable

Generally, longword references are used for sequential fetches. If the processor branches to an odd word address, a word-sized fetch is generated. The memory array of the instruction cache is enabled only if CENB is asserted.

- 0 = Cache disabled
- 1 = Cache enabled

CPDI - Disable CPUSHL Invalidation

When the privileged CPUSHL instruction is executed, the cache entry defined by bits [8:4] of the address is invalidated if CPDI = 0. If CPDI = 1, no operation is performed.

- 0 = Enable invalidation
- 1 = Disable invalidation

CFRZ - Cache Freeze

This field allows the user to freeze the contents of the cache. When CFRZ is asserted line fetches can be initiated and loaded into the line-fill buffer, but a valid cache entry can not be overwritten. If a given cache location is invalid, the contents of the line-fill buffer can be written into the memory array while CFRZ is asserted.

- 0 = Normal Operation
- 1 = Freeze valid cache lines

CINV - Cache Invalidate

Setting this bit forces the cache to invalidate each tag array entry. The invalidation process requires 32 machine cycles, with a single cache entry cleared per machine cycle. The state of this bit is always read as a zero. After a hardware reset, the cache must be invalidated before it is enabled.

- 0 = No operation
- 1 = Invalidate all cache locations

CEIB - Cache Enable Noncacheable Instruction Bursting

Setting this bit enables the line-fill buffer to be loaded with burst transfers under control of CLINF[1:0] for non-cacheable accesses. Noncacheable accesses are never written into the memory array.

- 0 = Disable burst fetches on noncacheable accesses
- 1 = Enable burst fetches on noncacheable accesses

DCM - Default Cache Mode

This bit defines the default cache mode: 0 is cacheable, 1 is noncacheable. For more information on the selection of the effective memory attributes, see **Section 4.3.2 Memory Reference Attributes**.

- 0 = Default cacheable
- 1 = Default noncacheable

DBWE - Default Buffered Write Enable

This bit defines the default value for enabling buffered writes. If DBWE = 0, the termination of an operand write cycle on the processor's local bus is delayed until the external bus cycle is completed. If DBWE = 1, the write cycle on the local bus is terminated immediately and the operation buffered in the bus controller. In this mode, operand write cycles are effectively decoupled between the processor's local bus and the external bus.

Generally, enabled buffered writes provide higher system performance but recovery from access errors can be more difficult. For the ColdFire CPU, reporting access errors on operand writes is always imprecise and enabling buffered writes simply further decouples the write instruction from the signaling of the fault

- 0 = Disable buffered writes
- 1 = Enable buffered writes

DWP - Default Write Protection

- 0 = Read and write accesses permitted
- 1 = Only read accesses permitted

CLNF[1:0] - Cache Line Fill

These bits control the size of the memory request the cache issues to the bus controller for different initial line access offsets.

Table 4-4. External Fetch Size Based on Miss Address and CLNF

CLNF[1:0]	LONGWORD ADDRESS BITS			
	00	01	10	11
00	Line	Line	Line	Longword
01	Line	Line	Longword	Longword
10	Line	Line	Line	Line
11	Line	Line	Line	Line

4.4.2.2 ACCESS CONTROL REGISTERS (ACR0, ACR1). The ACRs provide a definition of memory reference attributes for two memory regions (one per ACR). This set of effective attributes is defined for every memory reference using the ACRs or the set of default attributes contained in the CACR. The ACRs are examined for every memory reference that is NOT mapped to the SRAM module.

The ACRs are 32-bit write-only supervisor control registers. They are accessed in the CPU address space via the MOVEC instruction with an Rc encoding of \$004 and \$005. The ACRs can be read when in background debug mode (BDM). At system reset, the registers are cleared.

Access Control Registers (ACR0, ACR1)

31	30	29	28	27	26	25	24	23	22	21	20	19	18	17	16
AB31	AB30	AB29	AB28	AB27	AB26	AB25	AB24	AM31	AM30	AM29	AM28	AM27	AM26	AM25	AM24
RESET:															
0	0	0	0	0	0	0	0	0	0	0	0	0	0	0	0
15	14	13	12	11	10	9	8	7	6	5	4	3	2	1	0
EN	SM1	SM0	-	-	-	-	-	-	CM	BUFW	-	-	WP	-	-
RESET:															
0	0	0	0	0	0	0	0	0	0	0	0	0	0	0	0

AB[31:24] - Address Base [31:24]

This 8-bit field is compared to address bits [31:24] from the processor's local bus under control of the ACR address mask. If the address matches, the attributes for the memory reference are sourced from the given ACR.

AM[31:24] - Address Mask [31:24]

This 8-bit field can mask any bit of the AB field comparison. If a bit in the AM field is set, then the corresponding bit of the address field comparison is ignored.

EN - Enable

The EN bit defines the ACR enable. Hardware reset clears this bit, disabling the ACR.

- 0 = ACR disabled
- 1 = ACR enabled

SM[1:0] - Supervisor mode

This two-bit field allows the given ACR to be applied to references based on operating privilege mode of the ColdFire processor. The field uses the ACR for user references only, supervisor references only, or all accesses.

- 00 = Match if user mode
- 01 = Match if supervisor mode
- 1x = Match always - ignore user/supervisor mode

CM - Cache Mode

This bit defines the cache mode: 0 is cacheable, 1 is noncacheable.

- 0 = Caching enabled
- 1 = Caching disabled

BWE- Buffered Write Enable

This bit defines the value for enabling buffered writes. If BWE = 0, the termination of an operand write cycle on the processor's local bus is delayed until the external bus cycle is completed. If BWE = 1, the write cycle on the local bus is terminated immediately and the operation is then buffered in the bus controller. In this mode, operand write cycles are effectively decoupled between the processor's local bus and the external bus.

Generally, the enabling of buffered writes provides higher system performance but recovery from access errors may be more difficult. For the ColdFire CPU, the reporting of access errors on operand writes is always imprecise, and enabling buffered writes simply decouples the write instruction from the signaling of the fault even more.

- 0 = Don't buffer writes
- 1 = Buffer writes

WP - Write Protect

The WP bit defines the write-protection attribute. If the effective memory attributes for a given access select the WP bit, an access error terminates any attempted write with this bit set.

- 0 = Read and write accesses permitted
- 1 = Only read accesses permitted

SECTION 5 SRAM

5.1 SRAM FEATURES

- 8 KByte SRAM, organized as 2K x 32 Bits
- Single-Cycle Access
- Physically Located on ColdFire[®] core's High-Speed Local Bus
- Byte, Word, Longword Address Capabilities
- Memory Mapping Defined by the Customer

5.2 SRAM OPERATION

The SRAM module provides a general-purpose memory block that the ColdFire core can access in a single cycle. You can specify the location of the memory block to any 0-modulo-8K address within the four gigabyte address space. The memory is ideal for storing critical code or data structures or for use as the system stack. Because the SRAM module is physically connected to the processor's high-speed local bus, it can service core-initiated accesses or memory-referencing commands from the Debug module.

Depending on configuration information, instruction fetches can be sent to both the instruction cache and the SRAM block simultaneously. If the instruction fetch address is mapped into the region defined by the SRAM, the SRAM provides the data back to the processor, and the I-Cache data is discarded. Accesses from the SRAM and cache interaction are not cached.

5.3 PROGRAMMING MODEL

5.3.1 SRAM Register Memory Map

Table 5-1 below shows the memory map of the SRAM register.

The following lists several keynotes regarding the programming model table:

- The SRAM Base Address Register can only be accessed in supervisor mode using the MOVEC instruction with an Rc value of \$C04.
- Addresses not assigned to the register and undefined register bits are reserved for future expansion. Write accesses to these reserved address spaces and reserved register bits have no effect; read accesses will return zeros.
- The reset value column indicates the register initial value at reset. Certain registers can be uninitialized at reset, i.e., they may contain random values after reset.

- The access column indicates if the corresponding register allows both read/write functionality (R/W), read-only functionality (R), or write-only functionality (W). If a read access to a write-only register is attempted, zeros will be returned. If a write access to a read-only register is attempted the access will be ignored and no write will occur.

Table 5-1. Memory Map of SIM Registers

ADDRESS	NAME	WIDTH	DESCRIPTION	RESET VALUE	ACCESS
MOVEC with \$C04	RAMBAR	32	SRAM Base Address Register	uninitialized (except V=0)	W

5.3.2 SRAM Register

5.3.2.1 SRAM BASE ADDRESS REGISTER (RAMBAR). The RAMBAR determines the base address location of the internal SRAM module, as well as the definition of the types of accesses that are allowed for it.

The RAMBAR is a 32-bit write-only supervisor control register. It is accessed in the CPU address space via the MOVEC instruction with an Rc encoding of \$C04. The RAMBAR can be read when in Background Debug mode (BDM). At system reset, the V bit is cleared and the remainder bits of the RAMBAR are uninitialized. To access the SRAM module, RAMBAR should be written with the appropriate base address after system reset.

SRAM Base Address Register(RAMBAR)

31	30	29	28	27	26	25	24	23	22	21	20	19	18	17	16
BA31	BA30	BA29	BA28	BA27	BA26	BA25	BA24	BA23	BA22	BA21	BA20	BA19	BA18	BA17	BA16
RESET: - - - - - - - - - - - - - - - - -															
15	14	13	12	11	10	9	8	7	6	5	4	3	2	1	0
BA15	BA14	BA13	-	-	-	-	WP	-	-	C/I	SC	SD	UC	UD	V
RESET: - - - - - - - 0 0 - - - - - 0															

BA31-BA13 - Base Address

This field defines the base address location of the SRAM module. By programming this field, you can locate the SRAM anywhere within the four gigabyte ColdFire core address space.

WP - Write Protect

This field allows only read accesses to the SRAM. When this bit is set, any attempted write access will generate an access error exception in the MCF5206e.

- 0 = Allow read and write accesses to the SRAM module
- 1 = Allow only read accesses to the SRAM module

Freescale Semiconductor, Inc.

C/I, SC, SD, UC, UD - Address Space Masks

This field allows specific address spaces to be enabled or disabled, placing the internal modules in a specific address space. If an address space is disabled, an access to the register location in that address space becomes an external bus access, and the module resource is not accessed. The address space mask bits are:

C/I = CPU Space/Interrupt Acknowledge Cycle mask
 SC = Supervisor Code address space mask
 SD = Supervisor Data address space mask
 UC = User Code address space mask
 UD = User Data address space mask

For each address space bit:

0= An access to the internal module can occur for this address space.
 1= Disable this address space from the internal module selection. If this address space is used, no accesses occur to the internal peripheral, instead an external bus cycle will be generated.

V - Valid

This bit indicates when the contents of the RAMBAR are valid. The base address value is not used, and the SRAM module is not accessible until the V bit is set. An external bus cycle is generated if the base address field matches the internal core address, and the V bit is clear.

0 = Contents of RAMBAR are not valid.
 1 = Contents of RAMBAR are valid.

The mapping of a given access into the SRAM uses the following algorithm to determine if the access “hits” in the memory:

```

if (RAMBAR[0] = 1)
  if (requested address[31:9] = RAMBAR[31:9])
    if (address space mask of the requested type = 0)
      Access is mapped to the SRAM module
      if (access = read)
        Read the SRAM and return the data
      if (access = write)
        if (RAMBAR[8] = 0)
          Write the data into the SRAM
        else Signal a write-protect access error
  
```

5.3.3 SRAM Initialization

After a hardware reset, the contents of the SRAM module are undefined. The valid bit of the RAMBAR is cleared, disabling the module. If the SRAM needs to be initialized with instructions or data, you should perform the following steps:

1. Load the RAMBAR mapping the SRAM module to the desired location within the

address space.

2. Read the source data and write it to the SRAM. There are various instructions to support this function, including memory-to-memory move instructions, or the MOVEM opcode. The MOVEM instruction is optimized to generate line-sized burst fetches on 0-modulo-16 addresses, so this opcode generally provides maximum performance.
3. After the data has been loaded into the SRAM, it may be appropriate to load a revised value into the RAMBAR with a new set of attributes. These attributes consist of the write-protect and address space mask fields.

The ColdFire processor or an external emulator using the Debug module can perform these initialization functions.

5.3.4 Power Management

As noted previously, depending on the configuration defined by the RAMBAR, instruction fetch accesses can be sent to the SRAM module and the I-Cache simultaneously. If the access is mapped to the SRAM module, it sources the read data, discarding the I-Cache access. If the SRAM is used only for data operands, setting the SC and UC mask bits in the RAMBAR to 1 will lower power dissipation. This will disable the SRAM during all instruction fetches. Additionally, if the SRAM contains only instructions, setting the SD and UD mask bits in the RAMBAR to 1 masking operand accesses will reduce power dissipation.

Consider the examples on Table 5-2 of typical RAMBAR settings:

Table 5-2. Examples of Typical RAMBAR Settings

DATA CONTAINED IN SRAM	RAMBAR[7:0]
Code only	\$2B
Data only	\$35
Both Code and Data	\$21

SECTION 6

BUS OPERATION

The MCF5206e bus interface supports synchronous data transfers that can be terminated synchronously or asynchronously and also can be burst or burst-inhibited between the MCF5206e and other devices in the system. This section describes the function of the bus, the signals that control the bus, and the bus cycles provided for data-transfer operations. Operation of the bus is defined for transfers initiated by the MCF5206e as a bus master and for transfers initiated by an external bus master. When the DMA Controller has mastership, it is explicitly stated. The section includes descriptions of the error conditions, bus arbitration, and the reset operation.

6.1 FEATURES

The following list summarizes the key bus operation features:

- As many as 28 bits of address and 32 bits of data
- Accesses 8 bit, 16 bit, and 32 bit port sizes
- Generates byte, word, longword, and line size transfers
- Bus arbitration for external masters
- Burst and burst-inhibited transfer support
- Internal termination generation
- Termination generation for external masters

6.2 BUS AND CONTROL SIGNALS

6.2.1 Address Bus (A[27:0])

These three-state bidirectional signals provide the location of a bus transfer (except for interrupt-acknowledge transfers) when the MCF5206e is the bus master. When an external bus master controls the bus, the address signals are examined when transfer start (\overline{TS}) is asserted to determine if the MCF5206e should assert chip selects, DRAM control, and/or transfer terminal signals. During an interrupt-acknowledge access, address lines A[27:5] are driven high, A[1:0] are driven low, and A[4:2] indicate the interrupt level being acknowledged.

NOTE

The ColdFire® core outputs 32 bits of address to the internal bus controller. Of these 32 bits, only A[27:0] are output to pins on the MCF5206e. The output of A[27:24] depends on the setting of PAR[3:0] in the Pin Assignment Register (PAR) in the SIM. Refer to **6.3.2.10 Pin Assignment Register** on how to program the Pin Assignment Register (PAR).

6.2.2 Data Bus (D[31:0])

These three-state bidirectional signals provide the general-purpose data path between the MCF5206e and all other devices. The data bus can transfer 8, 16, 32, or 128 bits of data per bus transfer. A write cycle drives all 32 bits of the data bus regardless of the port width and operand size.

6.2.3 Transfer Start (\overline{TS})

The MCF5206e asserts this three-state bidirectional signal for one clock period to indicate the start of each bus cycle. During external master accesses, the MCF5206e monitors transfer start (\overline{TS}) to detect the start of each external master bus cycle to determine if chip select, DRAM, and/or transfer termination signals should be asserted.

6.2.4 Read/Write ($\overline{R/W}$)

This three-state bidirectional signal defines the data transfer direction for the current bus cycle. A high (logic one) level indicates a read cycle; a low (logic zero) level indicates a write cycle. When an external bus master is controlling the bus, the MCF5206e monitors this signal to determine if chip selects or DRAM control signals should be asserted.

6.2.5 Size (SIZ[1:0])

These three-state bidirectional signals indicate the data size for the bus cycle. When an external bus master is controlling the bus, the MCF5206e monitors these signals to determine the data size for asserting the appropriate memory control signals. Table 6-1 shows the definitions of the SIZx encoding.

Table 6-1. SIZx Encoding

SIZ1	SIZ0	TRANSFER SIZE
0	0	Longword (4 Bytes)
0	1	Byte
1	0	Word (2 Bytes)
1	1	Line (16 Bytes)

6.2.6 Transfer Type (TT[1:0])

These three-state output signals indicate the type of access for the current bus cycle. Table 6-2 lists the definitions of the TT_x encodings.

Table 6-2. Transfer Type Encoding

TT1	TT0	TRANSFER TYPE
0	0	Normal Access
0	1	On-board DMA Access
1	0	Debug Access
1	1	CPU Space/Acknowledge Access

The MCF5206e does not sample TT[1:0] during external master transfers.

6.2.7 Access Type and Mode (ATM)

This three-state output signal provides supplemental information for each transfer cycle type. Table 6-3 lists the encoding for normal, DMA debug and CPU space/acknowledge transfer types.

Table 6-3. ATM Encoding

TRANSFER TYPE	INTERNAL TRANSFER MODIFIER	ATM (TS=0)	ATM (TS=1)
00 (Normal Access)	Supervisor Code	1	1
	Supervisor Data	0	1
	User Code	1	0
	User Data	0	0
01 (DMA Access)	DMA Access	1	0
10 (Debug Access)	Supervisor Code	1	1
	Supervisor Data	0	1
11 (CPU Space/Acknowledge)	CPU Space - MOVEC Instruction	0	0
	Interrupt Acknowledge - Level 7	1	0
	Interrupt Acknowledge - Level 6	1	0
	Interrupt Acknowledge - Level 5	1	0
	Interrupt Acknowledge - Level 4	1	0
	Interrupt Acknowledge - Level 3	1	0
	Interrupt Acknowledge - Level 2	1	0
	Interrupt Acknowledge - Level 1	1	0

The MCF5206e does not sample ATM during external master transfers.

6.2.8 Asynchronous Transfer Acknowledge (\overline{ATA})

This active-low asynchronous input signal indicates the successful completion of a requested data transfer operation. Asynchronous transfer acknowledge (\overline{ATA}) is an input signal from the referenced slave device indicating completion of the transfer. \overline{ATA} is synchronized internal to the MCF5206e.

NOTE

The internal synchronized version of \overline{ATA} is referred to as “internal asynchronous transfer acknowledge.” During a read cycle, data is latched on the rising edge of CLK when the internal asynchronous transfer acknowledge is asserted. Consequently, data must remain valid for at least one and a half CLK cycles after the assertion of \overline{ATA} . Similarly, during a write cycle, data is driven until the falling edge of CLK when the internal asynchronous transfer acknowledge is asserted.

\overline{ATA} must be driven for one and half full clocks to ensure that the MCF5206e properly synchronizes the signal.

NOTE

For the MCF5206e to accept the transfer as successful with an \overline{ATA} , transfer error acknowledge \overline{TEA} must be negated until the internal asynchronous transfer acknowledge is asserted or the transfer is completed with a bus error.

Asynchronous transfer acknowledge (\overline{ATA}) is not used for termination during DRAM accesses.

6.2.9 Transfer Acknowledge (\overline{TA})

This three-state bidirectional active-low synchronous signal indicates the successful completion of a requested data transfer operation. During MCF5206e-initiated transfers, transfer acknowledge (\overline{TA}) is an input signal from the referenced slave device indicating completion of the transfer.

NOTE

For the MCF5206e to accept the transfer as successful with a transfer acknowledge, \overline{TEA} must be negated throughout the transfer.

\overline{TA} is not used for termination during MCF5206e-initiated DRAM accesses.

When an external master is controlling the bus, the MCF5206e can drive \overline{TA} to indicate the completion of the requested data transfer. If the external master-requested transfer is

to a chip select or default memory, the assertion of \overline{TA} is controlled by the number of wait states and the setting of the external master automatic acknowledge (EMAA) bit in the Chip Select Control Registers (CSCRs) or the Default Memory Control Register (DMCR). If the external master-requested transfer is a DRAM access, the MCF5206e drives \overline{TA} as an output and is asserted at the completion of the transfer.

6.2.10 Transfer Error Acknowledge (\overline{TEA})

The external slave asserts this active-low input signal to indicate an error condition for the current transfer. The assertion of \overline{TEA} immediately aborts the bus cycle. The assertion of \overline{TEA} has precedence over the assertion of asynchronous transfer acknowledge (\overline{ATA}) and transfer acknowledge (\overline{TA}).

NOTE

\overline{TEA} can be asserted up to one clock after the assertion of asynchronous transfer acknowledge (\overline{ATA}) and still be recognized.

\overline{TEA} has no affect during DRAM accesses.

6.3 BUS EXCEPTIONS

6.3.1 Double Bus Fault

If the MCF5206e experiences a double bus fault, it enters the halted state. To exit the halt state, reset the MCF5206e.

6.4 BUS CHARACTERISTICS

The MCF5206e uses the address bus (A[27:0]) to specify the location for a data transfer and the data bus (D[31:0]) to transfer the data. Control and attribute signals indicate the beginning and type of a bus cycle as well as the address space, direction, and size of the transfer. The selected device or the number of wait states programmed in the memory control register (the Chip Select Control Register (CSCR), the DRAM Controller Control Registers (DCCR, including the DRAM Controller Timing Register (DCTR)), or the Default Memory Control Register (DMCR)) control the length of the cycle.

The MCF5206e clock is distributed internally to provide logic timing. All bus signals are synchronous with the rising edge of CLK with the exception of row address strobes (RAS[1:0]) and column address strobes (CAS[3:0]), which can be asserted and negated synchronous with the falling edge of CLK.

Inputs to the MCF5206e (other than the interrupt priority level signals (\overline{IPLx}), reset in (RSTI) and \overline{ATA} signals) are synchronously sampled and must be stable during the sample window defined by t_{si} and t_{hi} (as shown in Figure 6-1) to guarantee proper operation. The asynchronous \overline{IPLx} , RSTI and \overline{ATA} signals are internally synchronized to resolve the input to a valid level before being used.

Outputs to the MCF5206e begin to transition on the rising CLK edges, with the exception of RAS[1:0] and CAS[3:0], which begin to transition on the falling CLK edges. Specifically, RAS[1:0] is asserted and negated synchronous with the falling edge of CLK, while CAS[3:0] is asserted synchronous with the falling edge of CLK and can be negated synchronous with either the falling edge or the rising edge of CLK.

During external master accesses where the MCF5206e drives \overline{TA} as an output, \overline{TA} is always driven negated for one clock cycle before being placed in a high-impedence state.

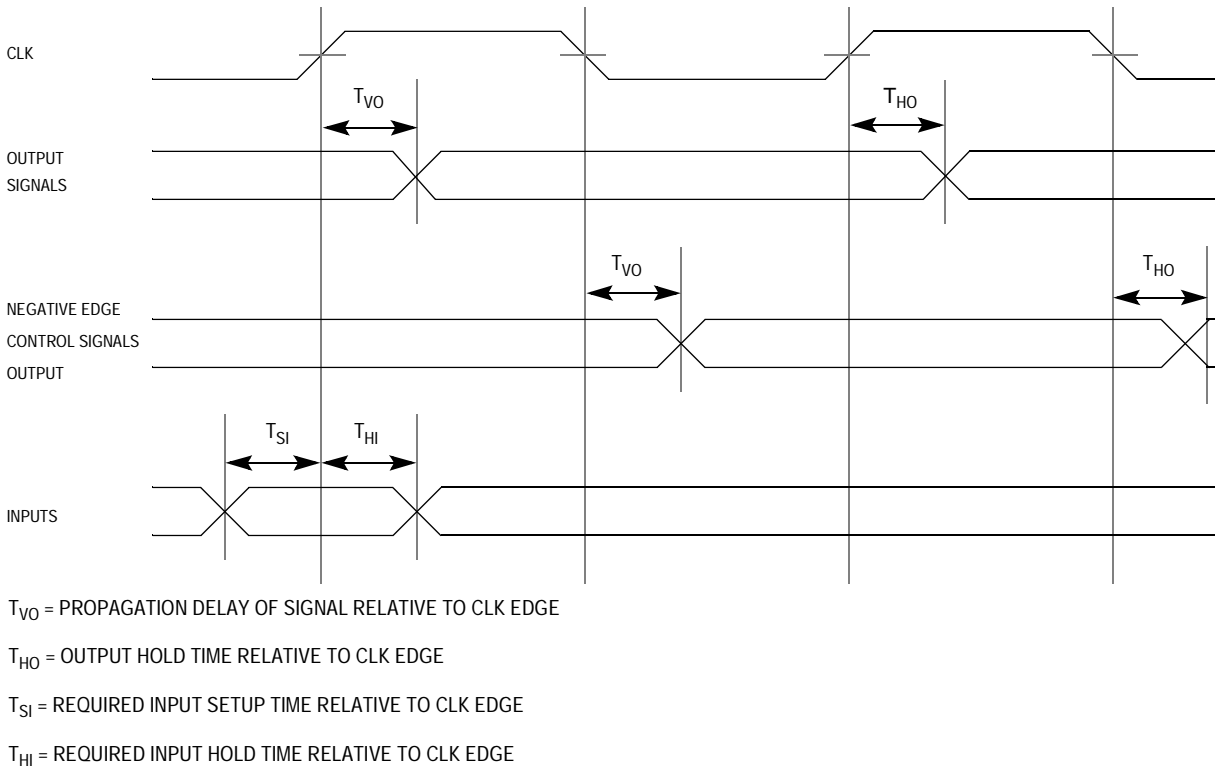

Figure 6-1. Signal Relationships to CLK

6.5 DATA TRANSFER MECHANISM

The MCF5206e supports byte, word, and longword operands and allows accesses to 8-, 16-, and 32-bit data ports. With the MCF5206e, you can select the port size of the specific memory, enable internal generation of transfer termination, and set the number of wait states for the external slave being accessed by programming the Chip Select Control Registers (CSCRs), the DRAM Controller Control Registers (DCCRs), and the Default Memory Control Register (DMCR). For more information on programming these registers, refer to the SIM, Chip Select, and DRAM Controller sections.

NOTE

The MCF5206e compares the address for the current bus transfer with the address and mask bits in the Chip Select

Address Registers (CSAR), DRAM Controller Address Registers (DCARs), the Chip Select Mask Registers (CSMR), and DRAM Controller Mask Registers (DCMR), looking for a match. The priority is listed in Table 6-4 (from highest priority to lowest priority):

Table 6-4. Chip Select, DRAM and Default Memory Address Decoding Priority

Chip Select 0
Chip Select 1
Chip Select 2
Chip Select 3
Chip Select 4
Chip Select 5
Chip Select 6
Chip Select 7
DRAM Bank 0
DRAM Bank 1
Default Memory

HIGHEST PRIORITY

The MCF5206e compares the address and mask in chip select 0 - 7 control registers (chip select 0 is compared first), then the address and mask in DRAM bank 0 - 1 control registers. If the address does not match in either or these, the MCF5206e uses the control bits in the Default Memory Control Register (DMCR) to control the bus transfer. If the Default Memory Control Register (DMCR) control bits are used, no chip select or DRAM control signals are asserted during the transfer.

6.5.1 Bus Sizing

The MCF5206e reads the port size for each transfer from either the Chip Select Control Registers (CSCRs), the DRAM Controller Control Registers (DCCRs), or the Default Memory Control Register (DMCR) at the start of each bus cycle. This allows the MCF5206e to transfer operands from 8-, 16-, or 32-bit ports. The size of the transfer is adjusted to accommodate the port size indicated. A 32-bit port must reside on data bus bits D[31:0], a 16-bit port must reside on data bus bits D[31:16], and an 8-bit port must reside on data bus bits D[31:24]. This requirement ensures that the MCF5206e correctly transfers valid data to 8-, 16-, and 32-bit ports.

The bytes of operands are designated as shown in Figure 6-2. The most significant byte of a longword operand is OP0; OP3 is the least significant byte. The two bytes of a word length operand are OP2 (most significant) and OP3. The single byte of a byte length operand is OP3. These designations are used in the figures and descriptions that follow.

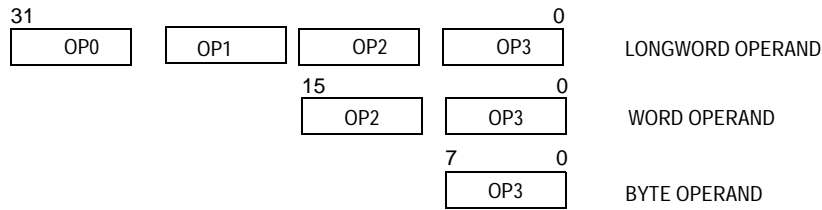

Figure 6-2. Internal Operand Representation

Figure 6-3 shows the required organization of data ports on the MCF5206e for 8-, 16-, and 32 bit devices. The four bytes shown are connected through the internal data bus and data multiplexer to the external data bus. This path is how the MCF5206e supports programmable port sizing and operand misalignment. The data multiplexer establishes the necessary connections for different combinations of address and data sizes.

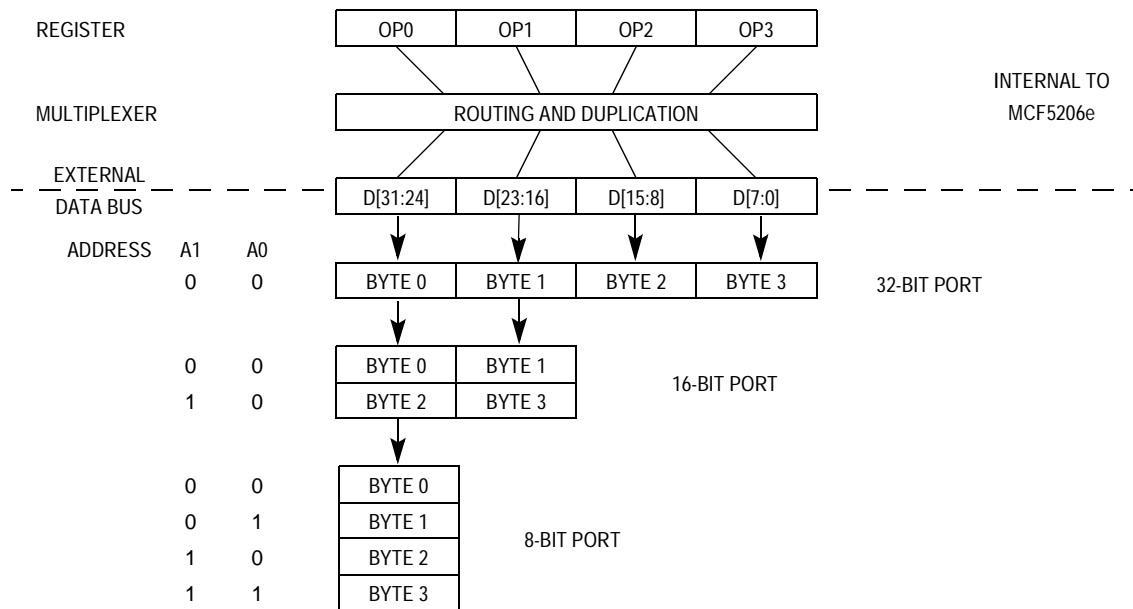

Figure 6-3. MCF5206e Interface to Various Port Sizes

The multiplexer takes the four bytes of the 32-bit bus and routes them to their required positions. For example, OP3 can be routed to D[7:0], as would be the normal case when interfacing to a 32-bit port. OP3 can be routed to D[23:16] for interfacing to a 16-bit port, or it can be routed to D[31:24] for interfacing to an 8-bit port. The operand size, address, and port size of the memory being accessed determines the positioning of bytes.

The MCF5206e can burst anytime the port size of the external slave being accessed is smaller than the operand size. If bursting is enabled, the MCF5206e performs burst transfers depending on the port size and operand alignment. For any transfer, the number of bytes transferred during a bus cycle is equal to or less than the size indicated by the SIZx outputs. For example, during the first bus cycle of a longword transfer to a 16-bit port where bursting is enabled, the SIZx outputs remains constant throughout the transfer and indicates that four bytes are to be transferred, although only two bytes are moved at a time. Table 6-5 lists the encodings for the SIZx bits for each port size for transfers where bursting is both enabled and disabled.

Table 6-5. SIZx Encoding for Burst- and Bursting-Inhibited Ports

OPERAND SIZE	32-BIT PORT				16 -BIT PORT				8-BIT PORT			
	BURSTING ENABLED		BURSTING INHIBITED		BURSTING ENABLED		BURSTING INHIBITED		BURSTING ENABLED		BURSTING INHIBITED	
	SIZ[1]	SIZ[0]	SIZ[1]	SIZ[0]	SIZ[1]	SIZ[0]	SIZ[1]	SIZ[0]	SIZ[1]	SIZ[0]	SIZ[1]	SIZ[0]
BYTE	0	1	0	1	0	1	0	1	0	1	0	1
WORD	1	0	1	0	1	0	1	0	1	0	0	1
LONGWORD	0	0	0	0	0	0	1	0	0	0	0	1
LINE	1	1	0	0	1	1	1	0	1	1	0	1

A[0] and A[1] also affect operation of the data multiplexer. During an operand transfer, A[31:2] indicate the longword base address of that portion of the operand to be accessed; A[1] and A[0] indicate the byte offset from the base. Table 6-6 lists the encoding of A[1] and A[0] and the corresponding byte offset from the longword base.

Table 6-6. Address Offset Encoding

A[1]	A[0]	OFFSET
0	0	+0 Byte
0	1	+1 Byte
1	0	+2 Bytes
1	1	+3 Bytes

Table 6-7 lists the bytes that should be driven on the data bus during read cycles by the slave device being accessed. The entries shown as Byte X are portions of the requested operand that are read. The operand being read is defined by SIZ[1], SIZ[0], A[0], and A[1] for the bus cycle. Bytes labeled X are “don’t cares” and are not required during that read cycle. Bytes labeled “-” indicates that this transfer is not valid.

Table 6-7. Data Bus Requirement for Read Cycles

TRANSFER SIZE	SIZE		ADDRESS		32 BIT PORT EXTERNAL DATA BYTES REQUIRED				16 BIT PORT EXTERNAL DATA BYTES REQUIRED		8 BIT PORT EXTERNAL DATA BYTES REQUIRED
	SIZ[1]	SIZ[0]	A[1]	A[0]	D[31:24]	D[23:16]	D[15:8]	D[7:0]	D[31:24]	D[23:16]	D[31:24]
BYTE	0	1	0	0	Byte 0	X	X	X	Byte 0	X	Byte 0
			0	1	X	Byte 1	X	X	X	Byte 1	Byte 1
			1	0	X	X	Byte 2	X	Byte 2	X	Byte 2
			1	1	X	X	X	Byte 3	X	Byte 3	Byte 3
WORD	1	0	0	0	Byte 0	Byte 1	X	X	Byte 0	Byte 1	Byte 0
			0	1	-	-	-	-	-	-	Byte 1
			1	0	X	X	Byte 2	Byte 3	Byte 2	Byte 3	Byte 2
			1	1	-	-	-	-	-	-	Byte 3
LONGWORD	0	0	0	0	Byte 0	Byte 1	Byte 2	Byte 3	Byte 0	Byte 1	Byte 0
			0	1	-	-	-	-	-	-	Byte 1
			1	0	-	-	-	-	Byte 2	Byte 3	Byte 2
			1	1	-	-	-	-	-	-	Byte 3
LINE	1	1	0	0	Byte 0	Byte 1	Byte 2	Byte 3	Byte 0	Byte 1	Byte 0
			0	1	-	-	-	-	-	-	Byte 1
			1	0	-	-	-	-	Byte 2	Byte 3	Byte 2
			1	1	-	-	-	-	-	-	Byte 3

Figure 6-4 is a flowchart for read transfers to 8-, 16-, or 32-bit ports. Bus operations are similar for each case and vary only with the size indicated, the portion of the data bus used for the transfer, and the specific number of cycles needed for each transfer.

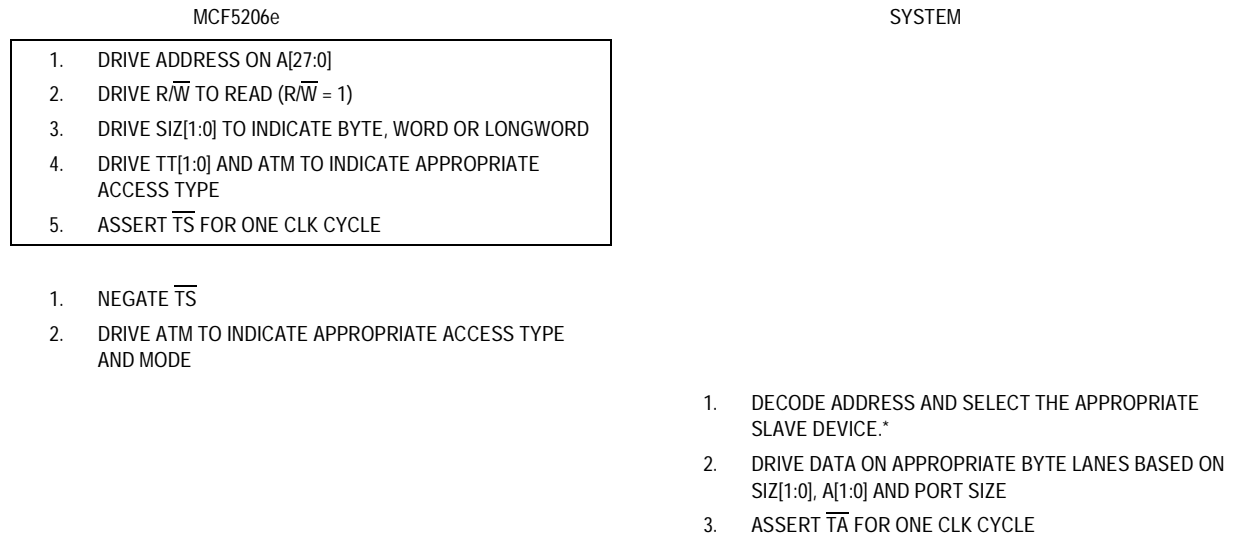

Figure 6-4. Byte-, Word-, and Longword-Read Transfer Flowchart

Figure 6-5 shows a longword supervisor code read from a 32-bit port.

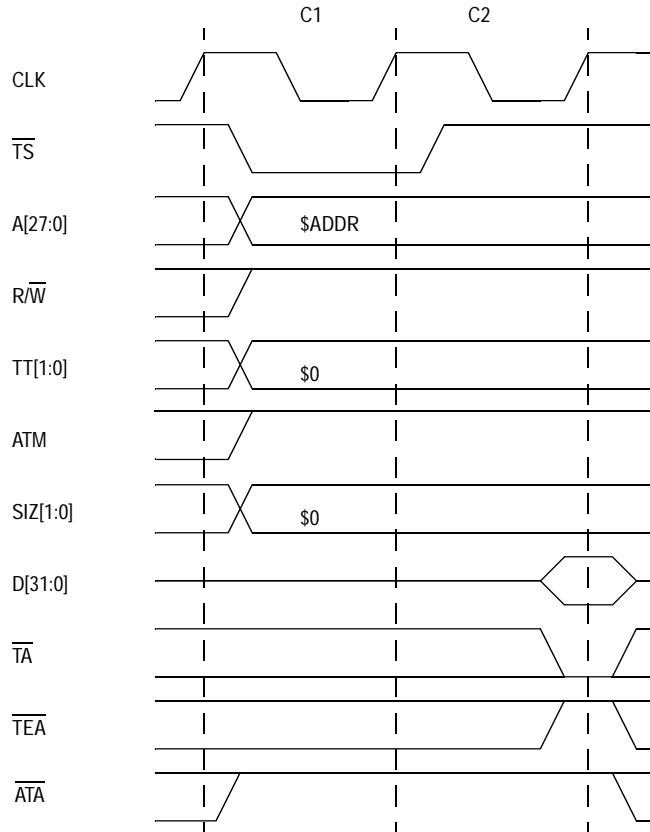

Figure 6-5. Longword-Read Transfer From a 32-Bit Port (No Wait States)

Clock 1 (C1)

The read cycle starts in C1. During C1, the MCF5206e places valid values on the address bus (A[27:0]) and transfer control signals. The transfer type (TT[1:0]) signals identify the specific access type. Access type and mode (ATM) identifies the transfer as reading code. The read/write (R/W) signal is driven high for a read cycle, and the size signals (SIZ[1:0]) are driven low to indicate a longword transfer. The MCF5206e asserts transfer start (TS) to indicate the beginning of a bus cycle.

Clock 2 (C2)

During C2, the MCF5206e negates transfer start (\overline{TS}), drives access type and mode (ATM) high to identify the transfer as supervisor. The selected device(s) places the addressed data onto D[31:0] and asserts the transfer acknowledge (\overline{TA}). At the end of C2, the MCF5206e samples the level of \overline{TA} and if \overline{TA} is asserted, latches the current value of D[31:0]. If \overline{TA} is asserted, the transfer of the longword is complete and the transfer terminates. If \overline{TA} is negated, the MCF5206e continues to sample \overline{TA} and inserts wait states instead of terminating the transfer. The MCF5206e continues to sample \overline{TA} on successive rising edges of CLK until it is asserted. If the bus monitor timer is enabled and

\overline{TA} is not asserted before the programmed bus monitor time is reached, the cycle is terminated with an internal bus error.

Table 6-8 lists the combinations of SIZ[1:0], A[1:0] and the corresponding pattern of the data transfer for write cycles from the internal multiplexer of the MCF5206e to the external data bus. For example, if a longword transfer is generated to a 16-bit port, the MCF5206e starts the cycle with A[1:0] set to \$0 and read the first word. The MCF5206e then increments A[1:0] to \$2 and reads the second word. The data for both word reads is sampled from DATA[31:16]. Bytes labeled X are “don’t cares.”

Table 6-8. Internal to External Data Bus Multiplexer - Write Cycle

TRANSFER SIZE	SIZE		ADDRESS		EXTERNAL DATA BUS CONNECTION			
	SIZ[1]	SIZ[0]	A[1]	A[0]	D[31:24]	D[23:16]	D[15:8]	D[7:0]
BYTE	0	1	0	0	OP3	X	X	X
			0	1	OP3	OP3	X	X
			1	0	OP3	X	OP3	X
			1	1	OP3	OP3	X	OP3
WORD	1	0	0	0	OP2	OP3	X	X
			0	1	OP3	X	X	X
			1	0	OP2	OP3	OP2	OP3
			1	1	OP3	X	X	X
LONGWORD	0	0	0	0	OP0	OP1	OP2	OP3
			0	1	OP1	X	X	X
			1	0	OP2	OP3	X	X
			1	1	OP3	X	X	X
LINE	1	1	0	0	OP0	OP1	OP2	OP3
			0	1	OP1	X	X	X
			1	0	OP2	OP3	X	X
			1	1	OP3	X	X	X

Figure 6-6 is a flowchart for write transfers to 8-, 16-, or 32-bit ports. Bus operations are similar for each case and vary only with the size indicated, the portion of the data bus used for the transfer and the specific number of cycles needed for each transfer.

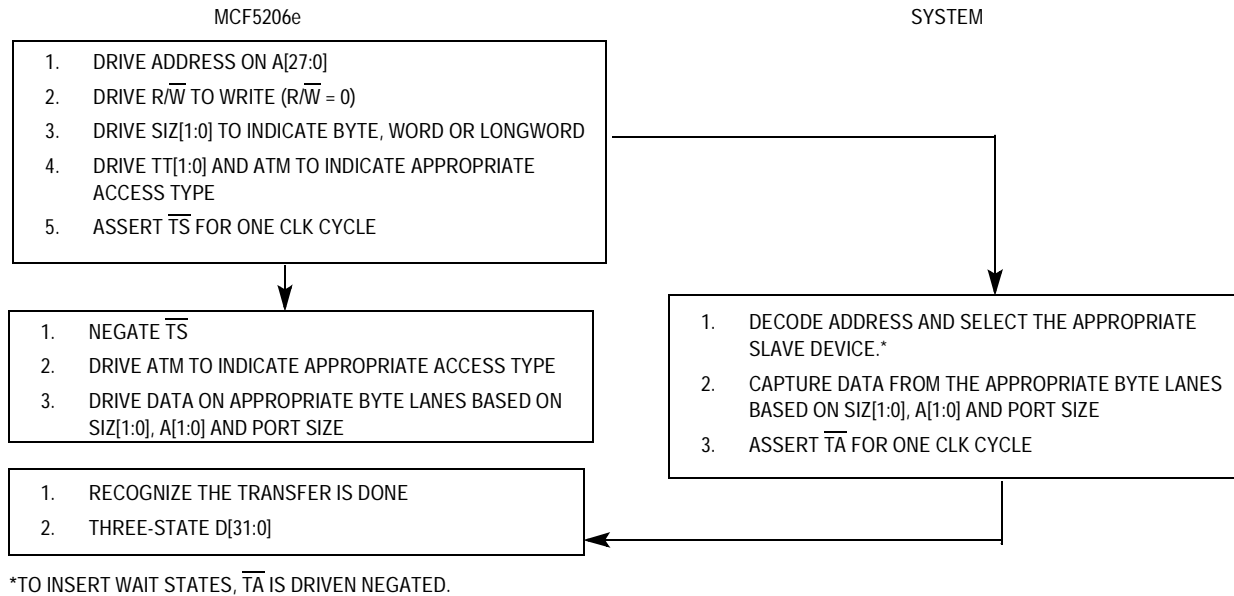

Figure 6-6. Byte-, Word-, and Longword-Write Transfer Flowchart

Figure 6-7 shows a supervisor data word-write transfer to a 16-bit port.

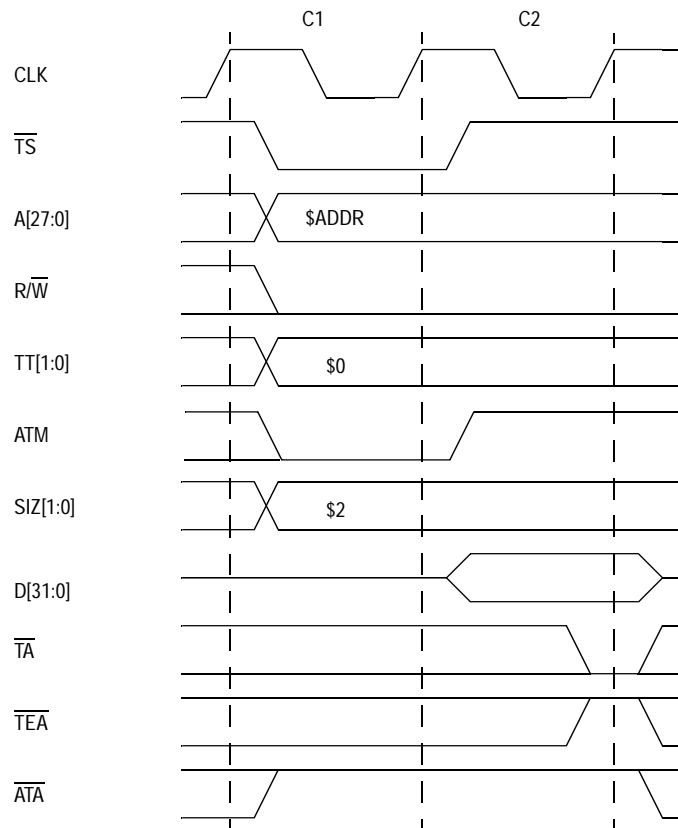

Figure 6-7. Word-Write Transfer to a 16-Bit Port (No Wait States)

Clock 1 (C1)

The write cycle starts in C1. During C1, the MCF5206e places valid values on the address bus (A[27:0]) and transfer control signals. The transfer type (TT[1:0]) signals identify the specific access type. Access type and mode (ATM) identifies the transfer as writing data. The read/write (R/ \overline{W}) signal is driven low for a write cycle, and the size signals (SIZ[1:0]) are driven to \$2 to indicate a word transfer. The MCF5206e asserts transfer start (\overline{TS}) to indicate the beginning of a bus cycle.

Clock 2 (C2)

During C2, the MCF5206e negates transfer start (\overline{TS}), drives ATM high to identify the transfer as supervisor, and places the data on the data bus (D[31:0]). The selected device(s) asserts the transfer acknowledge (\overline{TA}) if it is ready to latch the data. At the end of C2, the selected device latches the current value of D[31:16], and the MCF5206e samples the level of \overline{TA} . If \overline{TA} is asserted, the transfer of the word is complete and the transfer terminates. If \overline{TA} is negated, the MCF5206e continues to output the data and inserts wait states instead of terminating the transfer. The MCF5206e continues to sample \overline{TA} on successive rising edges of CLK until it is asserted.

6.5.2 Bursting Read Transfers: Word, Longword, and Line

If the burst-enable bit in the appropriate control register (Chip Select Control Register or Default Memory Control Register) is set to 1 or the transfer is to DRAM, and the operand size is larger than the port size of the memory being accessed, the MCF5206e performs word, longword, and line transfers in burst mode. When burst mode is selected, the size of the transfer (indicated by SIZ[1:0]) reflects the size of the operand being read, not the size of the port being accessed (i.e., a line transfer is indicated by SIZ[1:0] = \$3 and a longword transfer is indicated by SIZ[1:0] = \$0, regardless of the size of the port or the number of transfers required to access the entire set of data).

The MCF5206e supports burst-inhibited transfers for memory devices that cannot support bursting. For this type of bus cycle, you should clear the burst-enable bit in the Chip Select Control Registers (CSCRs) or Default Memory Control Register (DMCR).

NOTE

No burst-enable bit is provided for DRAM accesses. DRAM transfers are always bursted if the operand size is larger than the port size.

The MCF5206e uses line read transfers to access 16 Bytes to support cache line filling and for a MOVEM instruction, when appropriate. A line read accesses a block of four longwords, aligned to a longword memory boundary, by supplying a starting address that points to one of the longwords and incrementing A3, A2, A1, and A0 of the supplied address for each transfer. A longword read accesses a single longword aligned to a longword boundary and increments A1 and A0 if the accessed port size is smaller than 32 bits. A word read accesses a single word of data, aligned to a word boundary and increments A0 if the accessed port size is smaller than 16 bits.

Figure 6-8 is a flowchart for bursting read transfers to 8-, 16-, or 32-bit ports. Bus operations are similar for each case and vary only with the size indicated, the portion of the data bus used for the transfer, and the specific number of cycles needed for each transfer. A bursted read transfer can be from two to sixteen transfers long. The flowchart shown in Figure 6-8 is for a bursting transfer of four transfers long.

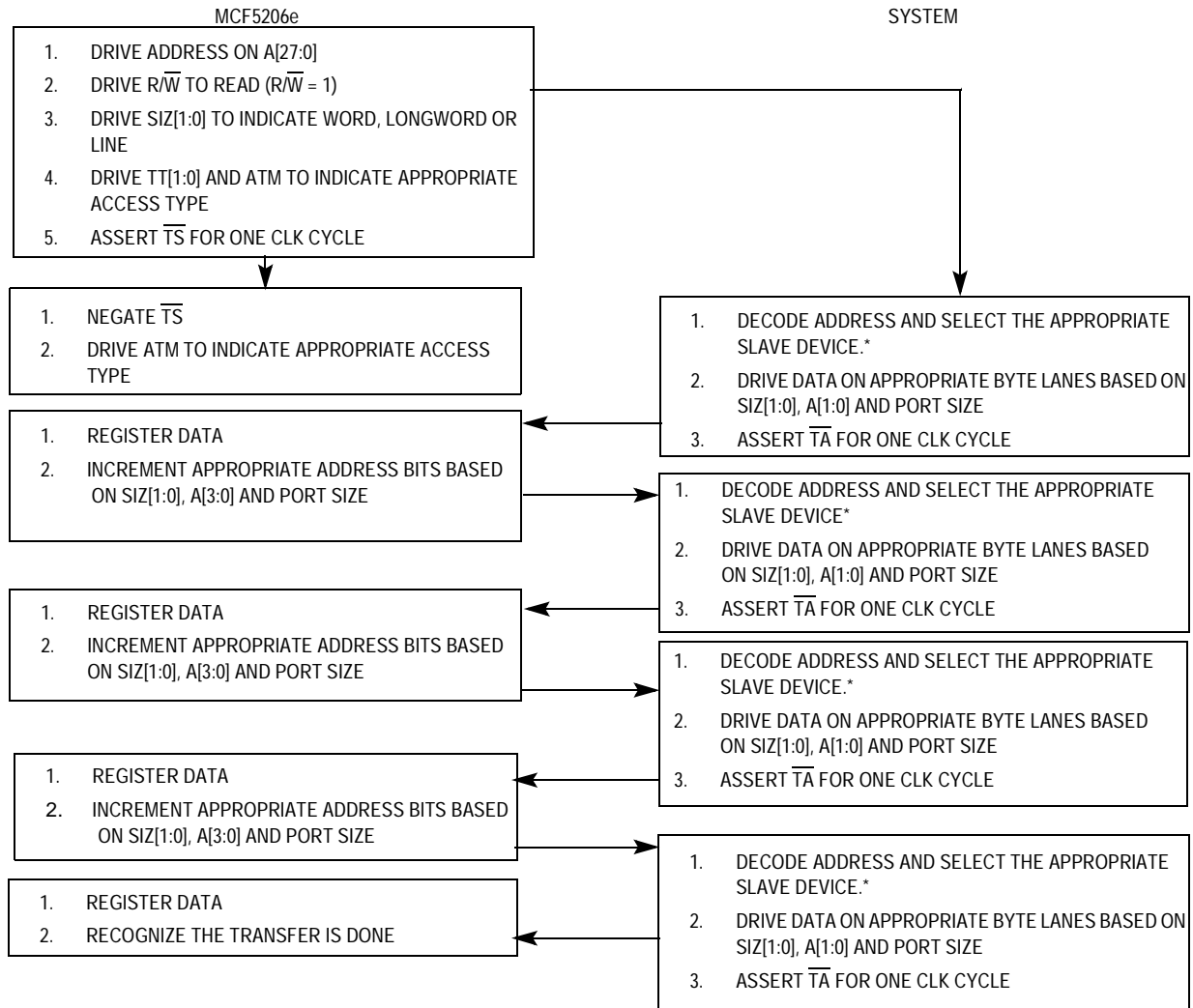

Figure 6-8. Bursting Word-, Longword-, and Line-Read Transfer Flowchart

Figure 6-9 shows a bursting user code word-read transfer from an 8-bit port.

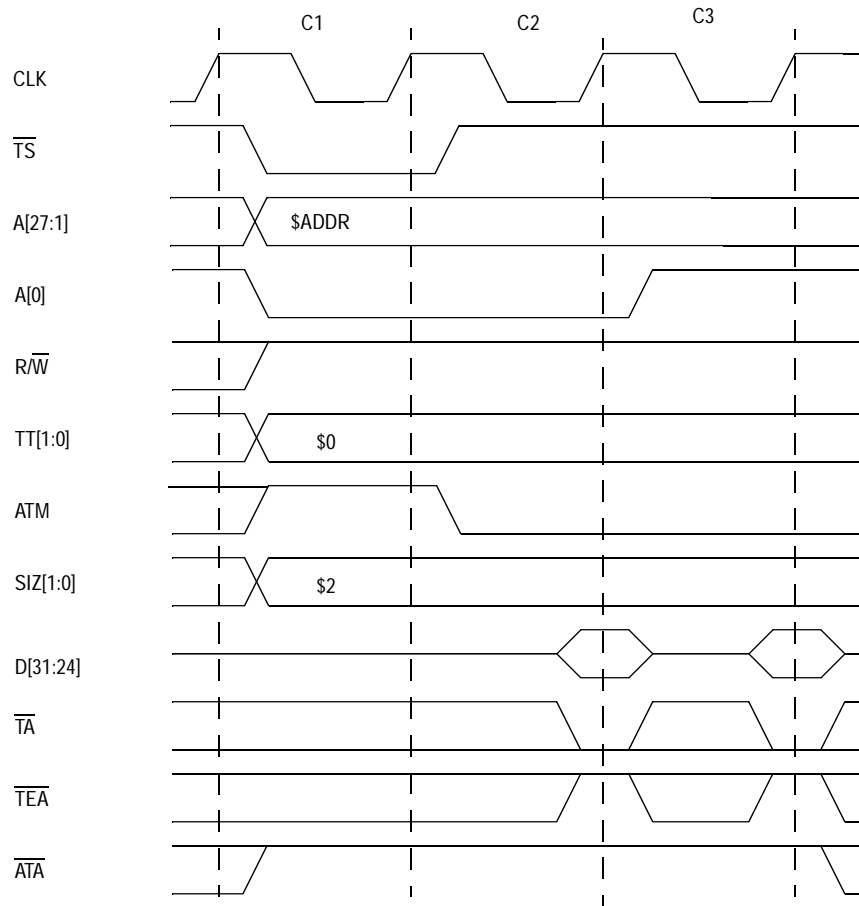

Figure 6-9. Bursting Word-Read From an 8-Bit Port (No Wait States)

Clock 1 (C1)

The read cycle starts in C1. During C1, the MCF5206e places valid values on the address bus (A[27:0]) and transfer control signals. The transfer type (TT[1:0]) signals identify the specific access type. Access transfer and mode (ATM) identifies the transfer as reading code. The read/write (R/W) signal is driven high for a read cycle, and the size signals (SIZ[1:0]) are driven to \$2 to indicate a word transfer. The MCF5206e asserts transfer start (TS) to indicate the beginning of a bus cycle.

Clock 2 (C2)

During C2, the MCF5206e negates TS, drives ATM low to identify the transfer as user. The selected device(s) places the first byte of the addressed data on to D[31:24] and asserts the transfer acknowledge (TA). At the end of C2, the MCF5206e samples the level of TA and if TA is asserted, latches the current value of D[31:24]. If TA is asserted, the transfer of the first byte of the word read is complete. If TA is negated, the MCF5206e continues to sample TA and inserts wait states instead of terminating the transfer. The MCF5206e continues to sample TA on successive rising edges of CLK until it is asserted.

Clock 3 (C3)

The MCF5206e increments A0 to address the next byte of the word transfer. The selected device(s) places the second byte of the addressed data onto D[31:24] and asserts the transfer acknowledge (\overline{TA}). At the end of C3, the MCF5206e samples the level of \overline{TA} and if \overline{TA} is asserted, latches the current value of D[31:24]. If \overline{TA} is asserted, the transfer of the word read is complete and the transfer is terminated. If \overline{TA} is negated, the MCF5206e continues to sample \overline{TA} and inserts wait states instead of terminating the transfer. The MCF5206e continues to sample \overline{TA} on successive rising edges of CLK until it is asserted.

6.5.3 Bursting Write Transfers: Word, Longword, and Line

The MCF5206e uses line-write transfers to access a 16-byte operand for a MOVEM instruction, when appropriate. A line write accesses a block of four longwords, aligned to a longword memory boundary, by supplying a starting address that points to one of the longwords and increments A[3], A[2], A[1], and A[0] of the supplied address for each transfer. A longword write accesses a single longword aligned to a longword boundary and increments A[1] and A[0] if the accessed port size is smaller than 32 bits. A word write accesses a single word of data, aligned to a word boundary and increments A0 if the accessed port size is smaller than 16 bits. Table 6-9 lists the encodings for the SIZx bits for each port size for transfers where bursting is both enabled and disabled.

Table 6-9. SIZx Encoding for Burst- and Bursting-Inhibited Ports

OPERAND SIZE	32-BIT PORT				16 -BIT PORT				8-BIT PORT			
	BURSTING ENABLED		BURSTING INHIBITED		BURSTING ENABLED		BURSTING INHIBITED		BURSTING ENABLED		BURSTING INHIBITED	
	SIZ[1]	SIZ[0]	SIZ[1]	SIZ[0]	SIZ[1]	SIZ[0]	SIZ[1]	SIZ[0]	SIZ[1]	SIZ[0]	SIZ[1]	SIZ[0]
BYTE	0	1	0	1	0	1	0	1	0	1	0	1
WORD	1	0	1	0	1	0	1	0	1	0	0	1
LONGWORD	0	0	0	0	0	0	1	0	0	0	0	1
LINE	1	1	0	0	1	1	1	0	1	1	0	1

Figure 6-10 is a flowchart for bursting write transfers to 8-, 16-, or 32-bit ports. Bus operations are similar for each case and vary only with the size indicated, the portion of the data bus used for the transfer and the specific number of cycles needed for each transfer. A bursted write transfer can be from two to sixteen transfers long. The flowchart in Figure 6-10 is for a bursting transfer of four transfers long.

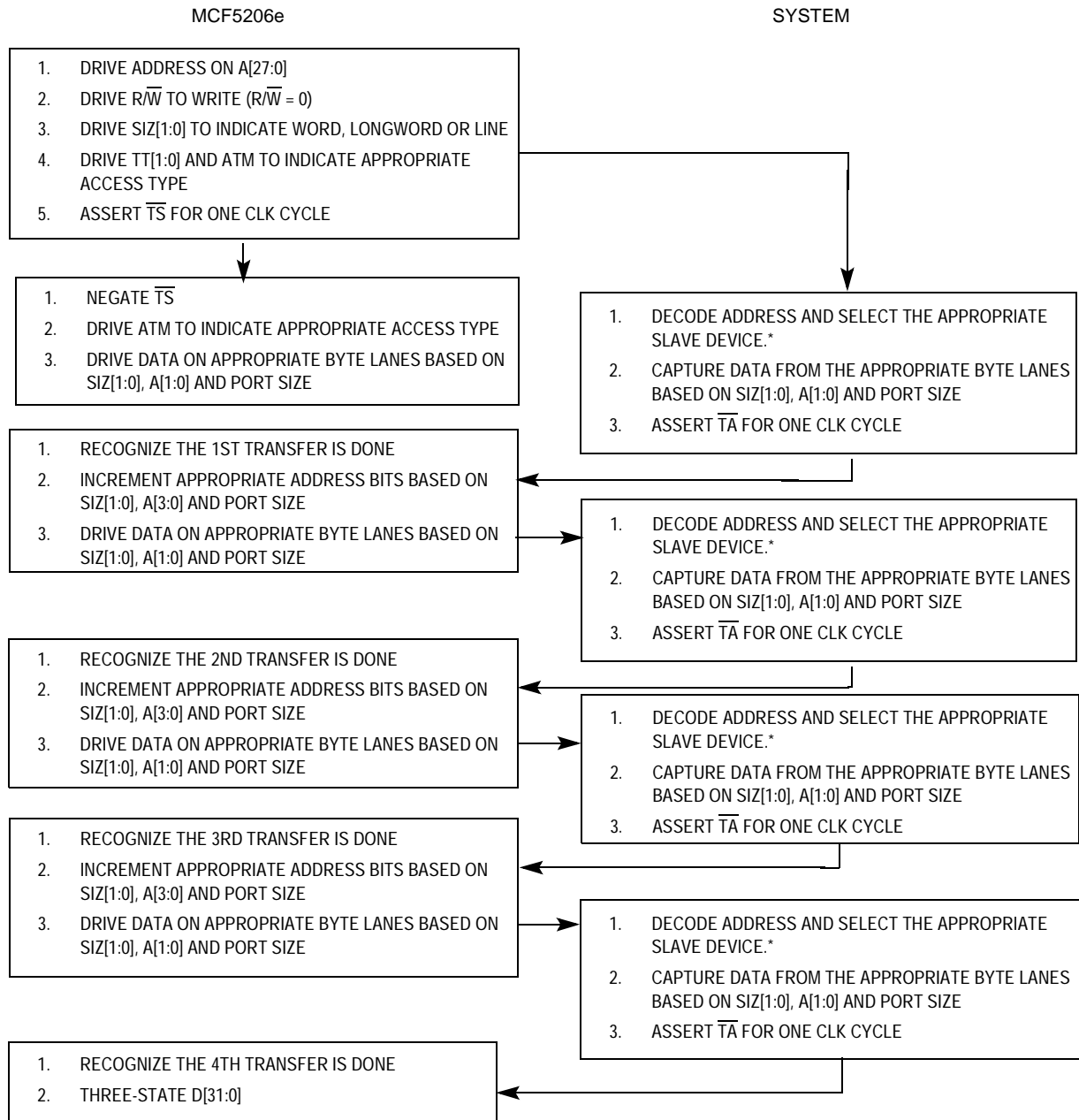

*TO INSERT WAIT STATES, TA IS DRIVEN NEGATED.

Figure 6-10. Word-, Longword-, and Line-Write Transfer Flowchart

Figure 6-11 shows a user data bursting line-write transfer to a 32-bit port.

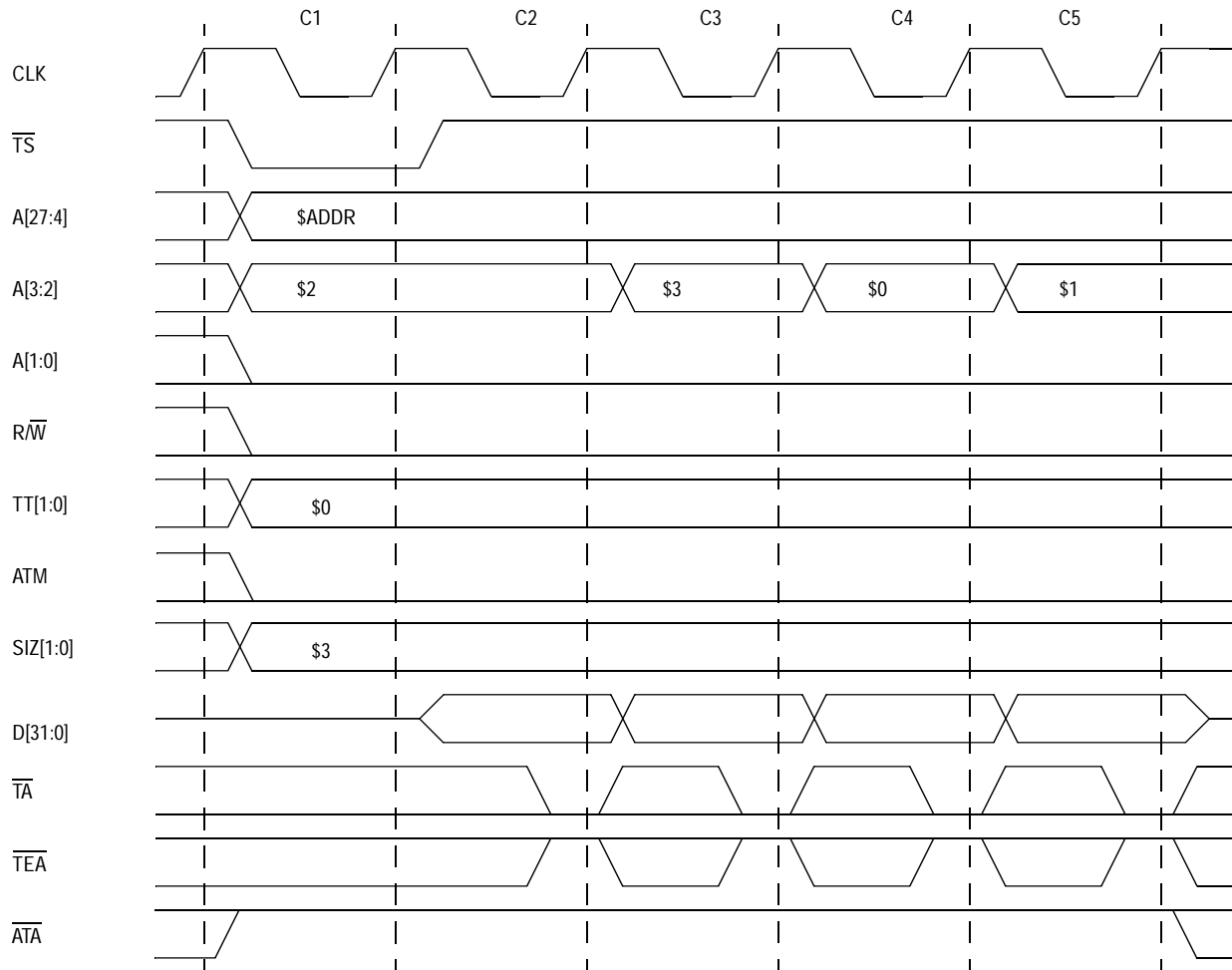

Figure 6-11. Line-Write Transfer to a 32-Bit Port (No Wait States)

Clock 1 (C1)

The write cycle starts in C1. During C1, the MCF5206e places valid values on the address bus (A[27:0]) and transfer control signals. The transfer type (TT[1:0]) signals identify the specific access type. Access type and mode (ATM) identifies the transfer as data. The read/write (R/W) signal is driven low for a write cycle, and the size signals (SIZ[1:0]) are driven to \$3 to indicate a line transfer. The MCF5206e asserts transfer start (TS) to indicate the beginning of a bus cycle.

Clock 2 (C2)

During C2, the MCF5206e negates \overline{TS} , drives ATM low to identify the transfer as user, and places the data on the data bus (D[31:0]). The selected device(s) asserts the transfer acknowledge (\overline{TA}) if it is ready to latch the data. At the end of C2, the selected device latches the current value of D[31:0], and the MCF5206e samples the level of \overline{TA} . If \overline{TA} is asserted, the transfer of the first longword is complete. If \overline{TA} is negated, the MCF5206e

continues to output the data and inserts wait states instead of terminating the transfer. The MCF5206e continues to sample \overline{TA} on successive rising edges of CLK until it is asserted.

Clock 3 (C3)

The MCF5206e increments A[3:2] to address the next longword of the line transfer and drives D[31:0] with the second longword of data. The selected device(s) asserts the \overline{TA} if it is ready to latch the data. At the end of C3, the MCF5206e samples the level of \overline{TA} and if \overline{TA} is asserted, the second longword transfer of the line write is complete. If \overline{TA} is negated, the MCF5206e continues to sample \overline{TA} and inserts wait states instead of terminating the transfer. The MCF5206e continues to sample \overline{TA} on successive rising edges of CLK until it is asserted.

Clock 4 (C4)

This clock is identical to C3 except that once \overline{TA} is asserted, the value corresponds to the third longword of data for the burst.

Clock 5 (C5)

This clock is identical to C3 except that once \overline{TA} is asserted, the data value corresponds to the fourth longword of data for the burst. This is the last CLK cycle of the line-write transfer and the MCF5206e three-states D[31:0] at the start of the next CLK cycle.

6.5.4 Burst-Inhibited Read Transfer: Word, Longword, and Line

If the burst-enable bit in the appropriate control register (Chip Select Control Register or Default Memory Control Register) is cleared and the operand size is larger than the port size of the memory being accessed, the MCF5206e performs word, longword, and line transfers in burst-inhibited mode. When burst-inhibit mode is selected, the size of the transfer (indicated by SIZ[1:0]) reflects the port size if the operand being read is larger than the port size or the operand size if the port size is larger than the operand size. A transfer size of line (SIZ[1:0] = \$3) is never indicated in burst-inhibited mode. If the operand size is line, the size pins (SIZ[1:0]) always indicate the port size. Refer to Table 6-9 for SIZx encodings for each port size for burst-inhibited transfers.

NOTE

All transfers to DRAM that have an operand size larger than the port size are bursted. Burst-inhibited transfers cannot be generated for DRAM accesses.

The basic transfer of a burst-inhibited read is the same as a “normal” read with the addition of more transfers until the entire operand has been accessed. Burst-inhibited read transfers can be from two to sixteen transfers long. Figure 6-12 is a flowchart for burst-inhibited read transfers (4 transfers long) to 8-, 16-, or 32-bit ports. Bus operations are similar for each case and vary only with the size indicated, the portion of the data bus used for the transfer, and the specific number of cycles needed for each transfer.

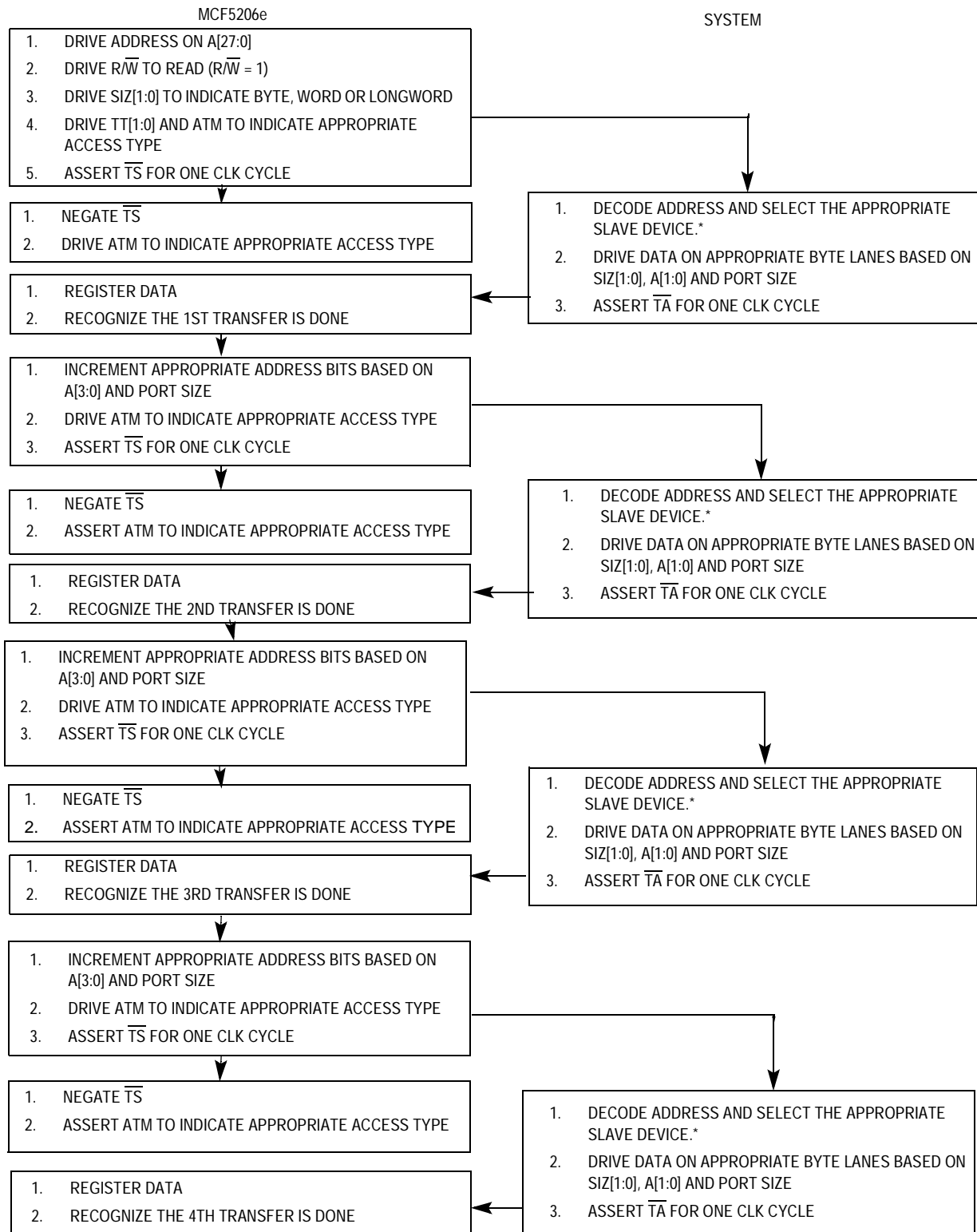

*TO INSERT WAIT STATES, \overline{TA} IS DRIVEN NEGATED.

Figure 6-12. Burst-Inhibited Word-, Longword-, and Line-Read Transfer Flowchart

Figure 6-13 shows a burst-inhibited supervisor code longword-read transfer from an 8-bit port.

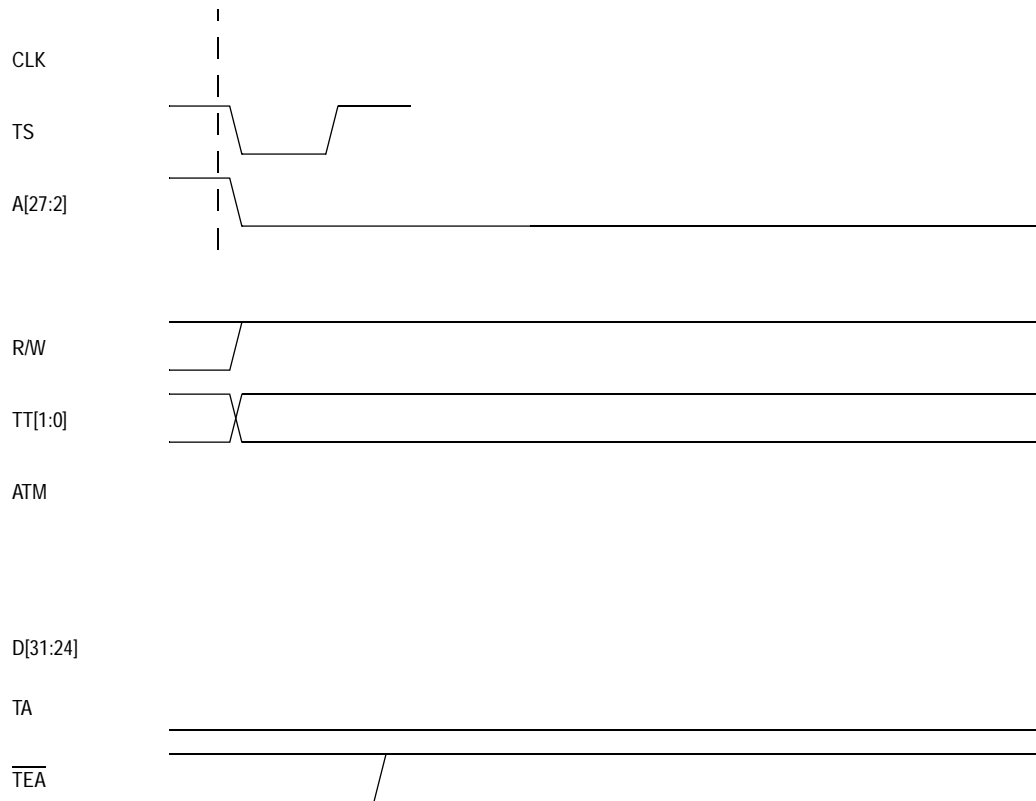

Figure 6-13. Burst-Inhibited Longword Read From an 8-Bit Port (No Wait States)

Clock 1 (C1)

The read cycle starts in C1. During C1, the MCF5206e places valid values on the address bus (A[27:0]) and transfer control signals. The transfer type (TT[1:0]) signals identify the specific access type and drives ATM high to identify the transfer as code. The read/write (R/W) signal is driven high for a read cycle, and the size signals (SIZ[1:0]) are driven to \$1 to indicate a byte transfer. The MCF5206e asserts TS to indicate the beginning of a bus cycle.

Clock 2 (C2)

During C2, the MCF5206e negates \overline{TS} and drives ATM high to identify the transfer as supervisor. The selected device(s) places the first byte of the addressed data onto D[31:24] and asserts \overline{TA} . At the end of C2, the MCF5206e samples the level of \overline{TA} and if \overline{TA} is asserted, latches the current value of D[31:24]. If \overline{TA} is asserted, the transfer of the first byte of the longword read is complete. If \overline{TA} is negated, the MCF5206e continues to

sample \overline{TA} and inserts wait states instead of terminating the transfer. The MCF5206e continues to sample \overline{TA} on successive rising edges of CLK until it is asserted.

Clock 3 (C3)

The MCF5206e increments A[1:0] to address the second byte of the longword transfer. The MCF5206e continues to drive transfer type (TT[1:0]), read/write (R/W) and size (SIZ[1:0]) signals to indicate a byte read. Access transfer mode (ATM) is driven high to indicate the transfer as code. The MCF5206e asserts \overline{TS} to indicate the beginning of the second transfer of the bus cycle.

Clock 4 (C4)

This clock is identical to C2 except that once \overline{TA} is recognized asserted, the latched value corresponds to the second byte of data for the longword transfer.

Clock 5 (C5)

This clock is identical to C3 except the address is incremented to address the third byte of the longword transfer.

Clock 6 (C6)

This clock is identical to C2 except that once \overline{TA} is recognized asserted, the latched value corresponds to the third byte of data for the longword transfer.

Clock 7 (C7)

This clock is identical to C3 except the address is incremented to address the fourth byte of the longword transfer.

Clock 8 (C8)

This clock is identical to C2 except that once \overline{TA} is recognized asserted, the latched value corresponds to the fourth byte of data for the longword. This is the last CLK cycle of the longword-read transfer. The selected device negates \overline{TA} signal and three-states D[31:24] after the next rising edge of CLK.

6.5.5 Burst-Inhibited Write Transfer: Word, Longword, and Line

The basic transfer of a burst-inhibited write is the same as “normal” write with the addition of more transfers until the entire operand has been accessed. Burst-inhibited write transfers can be from two to 16 transfers long. Figure 6-14 is a flowchart for burst-inhibited write transfers (4 transfers long) to 8-, 16-, or 32-bit ports. Bus operations are similar for each case and vary only with the size indicated, the portion of the data bus used for the transfer, and the specific number of cycles needed for each transfer.

Figure 6-14. Burst-Inhibited Byte-, Word-, and Longword-Write Transfer Flowchart

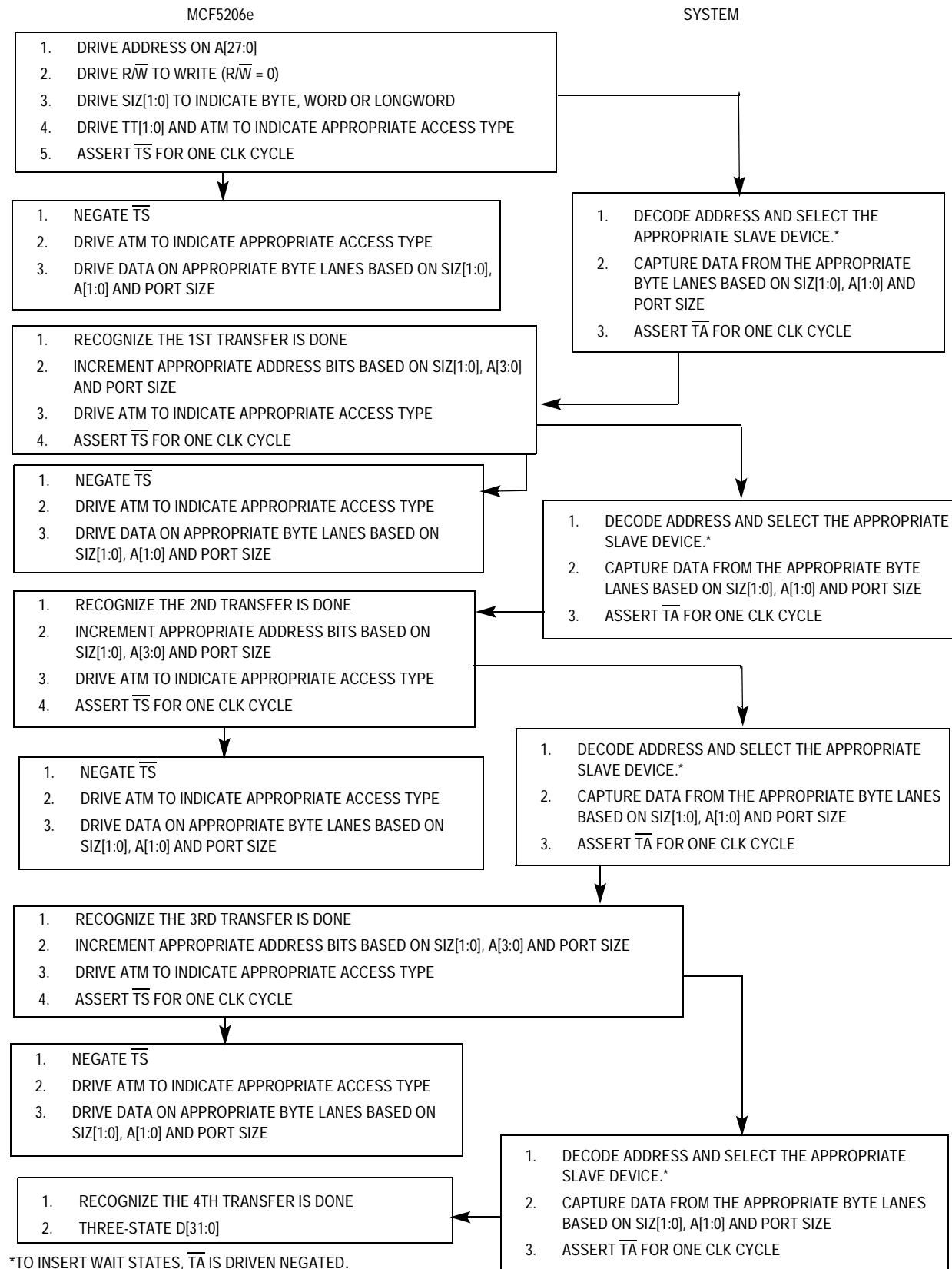

Freescale Semiconductor, Inc.

Figure 6-15 shows a burst-inhibited supervisor data longword-write transfer to a 16-bit port.

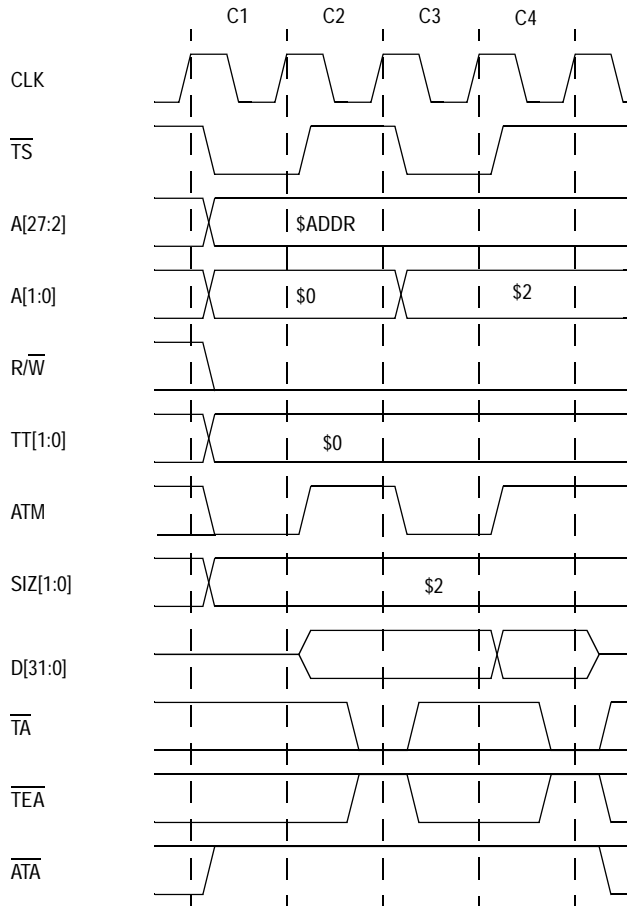

Figure 6-15. Burst-Inhibited Longword-Write Transfer to a 16-Bit Port (No Wait States)

Clock 1 (C1)

The write cycle starts in C1. During C1, the MCF5206e places valid values on the address bus (A[27:0]) and transfer control signals. The transfer type (TT[1:0]) signals identify the specific access type and ATM identifies the transfer as data. The read/write (R/W) signal is driven low for a write cycle, and the size signals (SIZ[1:0]) are driven to \$2 to indicate a word transfer. The MCF5206e asserts \overline{TS} to indicate the beginning of a bus cycle.

Clock 2 (C2)

During C2, the MCF5206e negates \overline{TS} , drives ATM high to identify the transfer as supervisor and places the data on the data bus (D[31:0]). The selected device(s) asserts \overline{TA} if it is ready to latch the data. At the end of C2, the selected device latches the current value of D[31:16], and the MCF5206e samples the level of \overline{TA} . If \overline{TA} is asserted, the transfer of the first word is complete. If \overline{TA} is negated, the MCF5206e continues to output

the data and inserts wait states instead of terminating the transfer. The MCF5206e continues to sample \overline{TA} on successive rising edges of CLK until it is asserted.

Clock 3 (C3)

The MCF5206e increments A[1:0] to address the next word, asserts \overline{TS} and drives ATM low to identify the transfer as code or data.

Clock 4 (C4)

This clock is identical to C2 except that the data driven corresponds to the second word of data. This is the last CLK cycle of the longword-write transfer and the MCF5206e three-states D[31:0] at the start of the next CLK cycle.

6.5.6 Asynchronous-Acknowledge Read Transfer

The MCF5206e provides an asynchronous acknowledge that can be used for termination of all MCF5206e transfers except accesses to DRAM. \overline{ATA} is synchronized internally before being used. If recognition by a specific CLK rising edge is required, \overline{ATA} must meet the specified setup and hold times to CLK. Because of the internal synchronization of \overline{ATA} , data must be driven on the bus until the asynchronous transfer acknowledge is recognized internally. If transfer error acknowledge (\overline{TEA}) is asserted while \overline{ATA} is being synchronized internally, the transfer terminates in an error.

NOTE

The internal synchronized version of (\overline{ATA}) is referred to as “internal asynchronous transfer acknowledge.” Because of the time required to internally synchronize \overline{ATA} during a read cycle, data is latched on the rising edge of CLK when the internal asynchronous transfer acknowledge is asserted. Consequently, data must remain valid for at least one and half CLK cycles after the assertion of \overline{ATA} . Similarly, during a write cycle, data is driven until the falling edge of CLK when the internal asynchronous transfer acknowledge is asserted.

Figure 6-16 is a flowchart for read transfers to 8-, 16-, or 32-bit ports with asynchronous termination. Bus operations are similar for each case and vary only with the size indicated,

the portion of the data bus used for the transfer, and the specific number of cycles needed for each transfer.

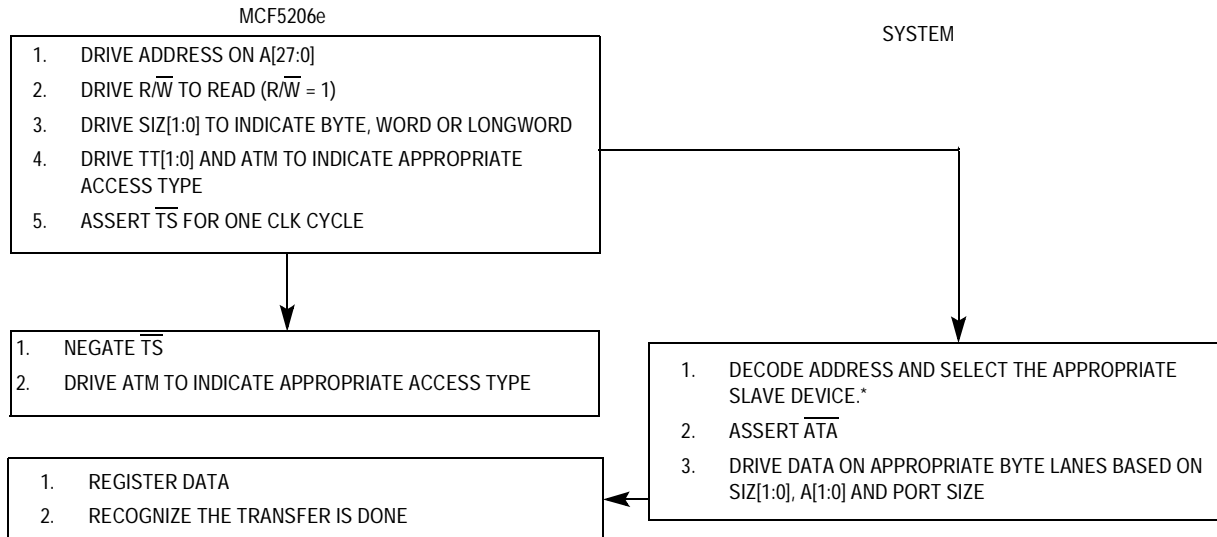

*TO INSERT WAIT STATES, \overline{ATA} IS DRIVEN NEGATED.

Figure 6-16. Byte-, Word-, and Longword-Read Transfer with Asynchronous Termination Flowchart (One Wait State)

NOTE

Zero-wait-state operation can be achieved with asynchronous termination by asserting asynchronous termination acknowledge (\overline{ATA}) before the CLK cycle transfer start (\overline{TS}) is asserted. This may only be practical if \overline{ATA} is tied to GND. Refer to **3.5.12 Termination Tied to GND** for more information.

Figure 6-17 shows a user code byte read from an 8-bit port.

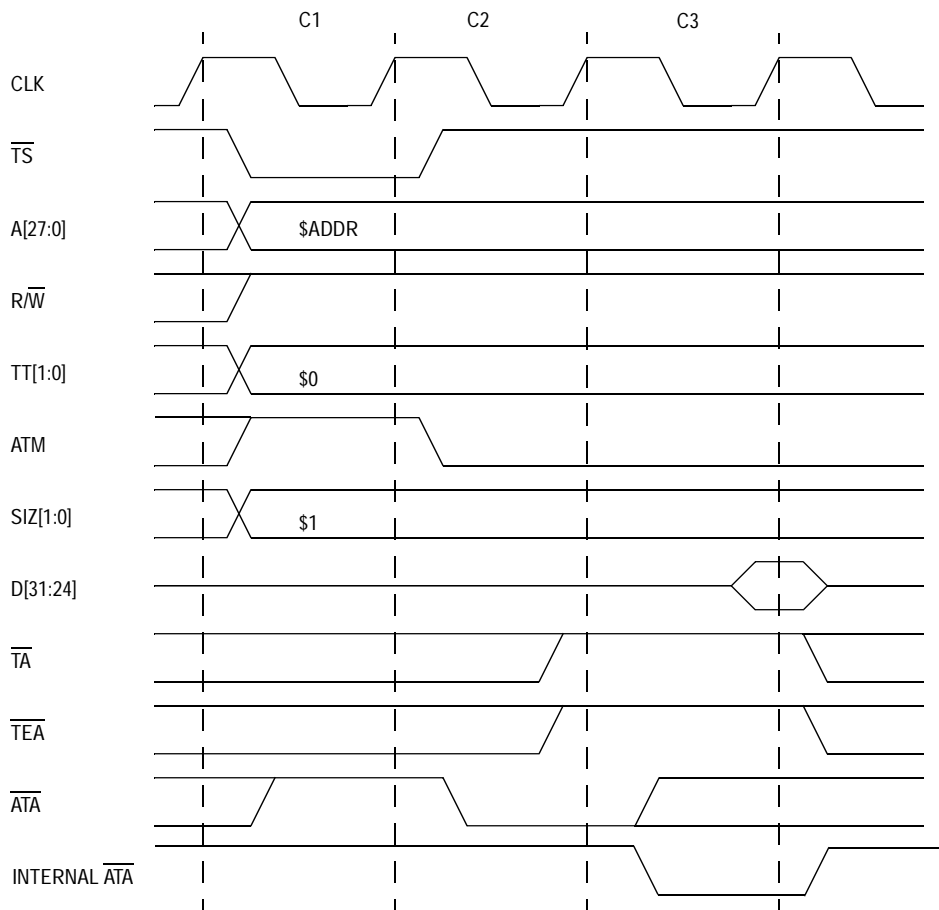

Figure 6-17. Byte-Read Transfer from an 8-Bit Port Using Asynchronous Termination (One Wait State)

Clock 1 (C1)

The read cycle starts in C1. During C1, the MCF5206e places valid values on the address bus (A[27:0]) and transfer control signals. The transfer type (TT[1:0]) signals identify the specific access type and ATM identifies the transfer as code. The read/write (R/W) signal is driven high for a read cycle, and the size signals (SIZ[1:0]) are driven to \$1 to indicate a byte transfer. The MCF5206e asserts \overline{TS} to indicate the beginning of a bus cycle.

Clock 2 (C2)

During C2, the MCF5206e negates \overline{TS} and drives ATM low to identify the transfer as user. The selected device(s) asserts \overline{ATA} with the required setup time prior to the falling clock edge.

Clock 3 (C3)

At the end of C3, the MCF5206e samples the level of internal asynchronous transfer acknowledge and if it is asserted, latches the current value of D[31:24]. If internal asynchronous transfer acknowledge is asserted, the byte transfer is complete and the transfer terminates. If internal asynchronous transfer acknowledge is negated, the MCF5206e continues to sample internal asynchronous transfer acknowledge and inserts wait states instead of terminating the transfer. The MCF5206e continues to sample internal asynchronous transfer acknowledge until it is asserted. As long as \overline{ATA} is asserted prior to the falling edge of C2, internal asynchronous transfer acknowledge is asserted by the rising edge of C3.

6.5.7 Asynchronous Acknowledge Write Transfer

Figure 6-18 is a flowchart for write transfers to 8-, 16-, or 32-bit ports with asynchronous termination. Bus operations are similar for each case and vary only with the size indicated, the portion of the data bus used for the transfer, and the specific number of cycles needed for each transfer.

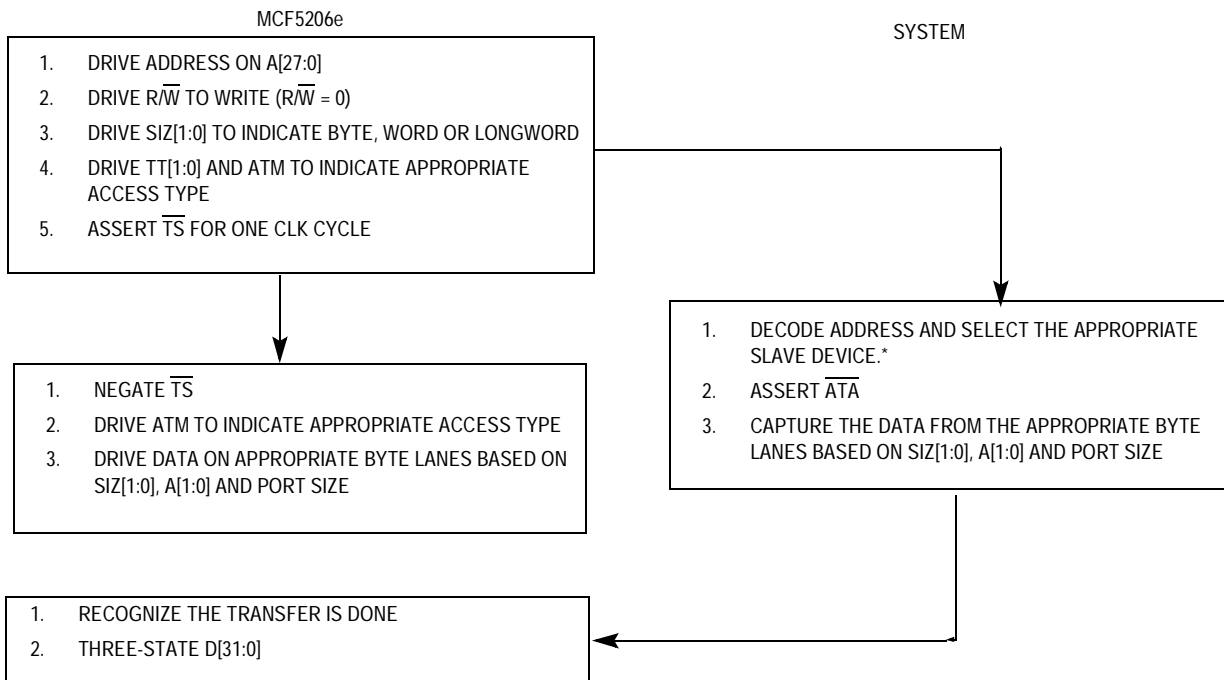

*TO INSERT WAIT STATES, \overline{ATA} IS DRIVEN NEGATED.

Figure 6-18. Byte-, Word-, and Longword-Write Transfer with Asynchronous Termination Flowchart

Figure 6-19 shows a user data byte transfer to a 32-bit port with asynchronous termination.

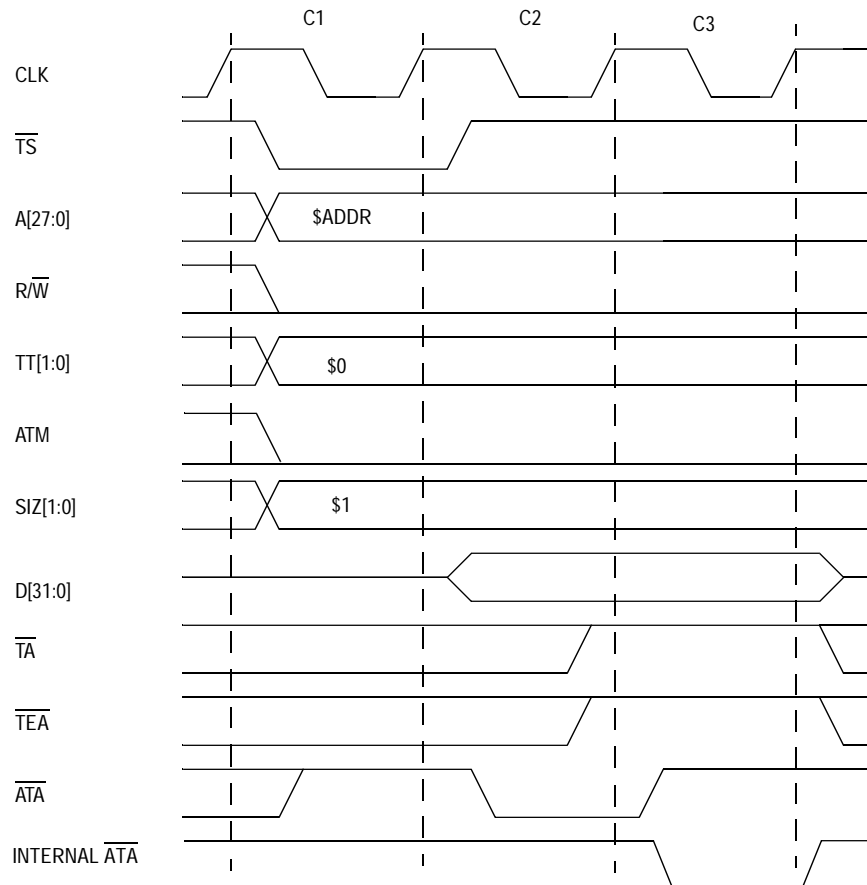

Figure 6-19. Byte-Write Transfer to a 32-Bit Port Using Asynchronous Termination (One Wait State)

Clock 1 (C1)

The write cycle starts in C1. During C1, the MCF5206e places valid values on the address bus (A[27:0]) and transfer control signals. The transfer type (TT[1:0]) signals identify the specific access type and ATM identifies the transfer as data. The read/write ($\overline{R/W}$) signal is driven low for a write cycle, and the size signals (SIZ[1:0]) are driven to $\$1$ to indicate a byte transfer. The MCF5206e asserts \overline{TS} to indicate the beginning of a bus cycle.

Clock 2 (C2)

During C2, the MCF5206e negates \overline{TS} , drives ATM low to identify the transfer as user and places the data on the data bus (D[31:0]). The selected slave device asserts \overline{ATA} prior to the falling edge of the clock. The selected slave device may latch the data present on the data bus or may wait until the end of Clock 3 (after internal asynchronous transfer acknowledge has been asserted).

Clock 3 (C3)

At the end of C3, the MCF5206e samples the level of internal asynchronous transfer acknowledge and if it is asserted, the transfer of the byte is complete and the transfer terminates. If internal asynchronous transfer acknowledge is negated, the MCF5206e continues to sample internal asynchronous transfer acknowledge and inserts wait states instead of terminating the transfer. The MCF5206e continues to sample internal asynchronous transfer acknowledge until it is asserted. As long as \overline{ATA} is asserted prior to the falling edge of C2 meeting the setup time requirement, internal asynchronous transfer acknowledge is asserted by the rising edge of C3.

6.5.8 Bursting Read Transfers: Word, Longword, and Line with Asynchronous Acknowledge

If the burst-enable bit in the appropriate Chip Select Control Register (CSCR) or Default Memory Control Register (DMCR) is set to 1 and the operand size is larger than the port size of the memory being accessed, the MCF5206e performs word, longword, and line transfers in burst mode. When burst mode is selected and the transfer is not to DRAM, the transfer can be terminated synchronously using \overline{TA} , or asynchronously using \overline{ATA} . The transfer attributes are the same for both the synchronous and asynchronously terminated burst transfers.

Figure 6-20 is a flowchart for bursting read transfers to 8-, 16-, or 32-bit ports using asynchronous termination. Bus operations are similar for each case and vary only with the size indicated, the portion of the data bus needed for the transfer, and the specific number of cycles used for each transfer. A bursted transfer can be from two to 16 transfers long.

The flow chart shown is for four bursting transfers.

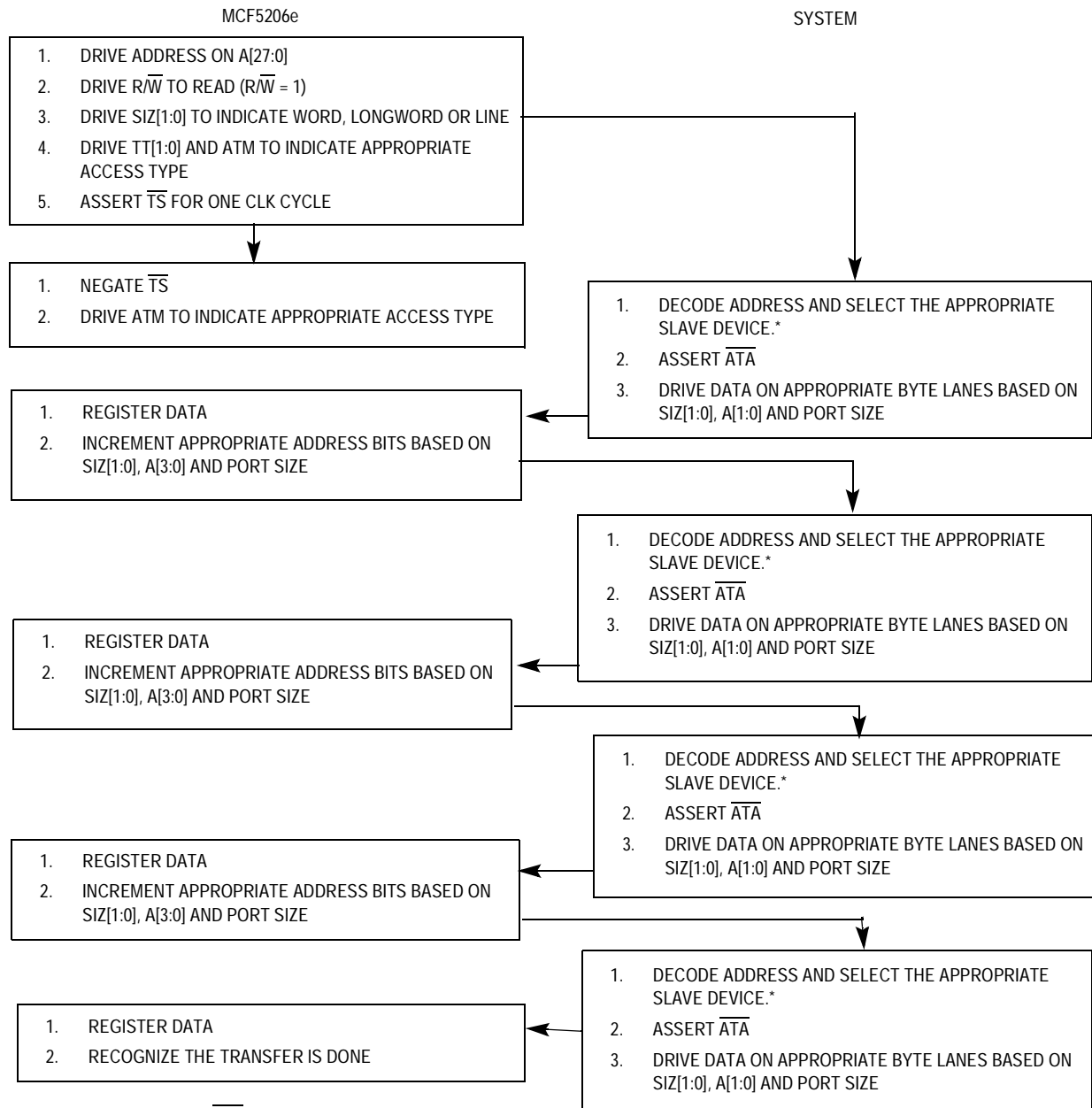

*TO INSERT WAIT STATES, \overline{ATA} IS DRIVEN NEGATED.

Figure 6-20. Bursting Word-, Longword-, and Line-Read Transfer with Asynchronous Termination Flowchart

Freescale Semiconductor, Inc.

Figure 6-21 shows a bursting supervisor data longword-read transfer from a 16-bit port.

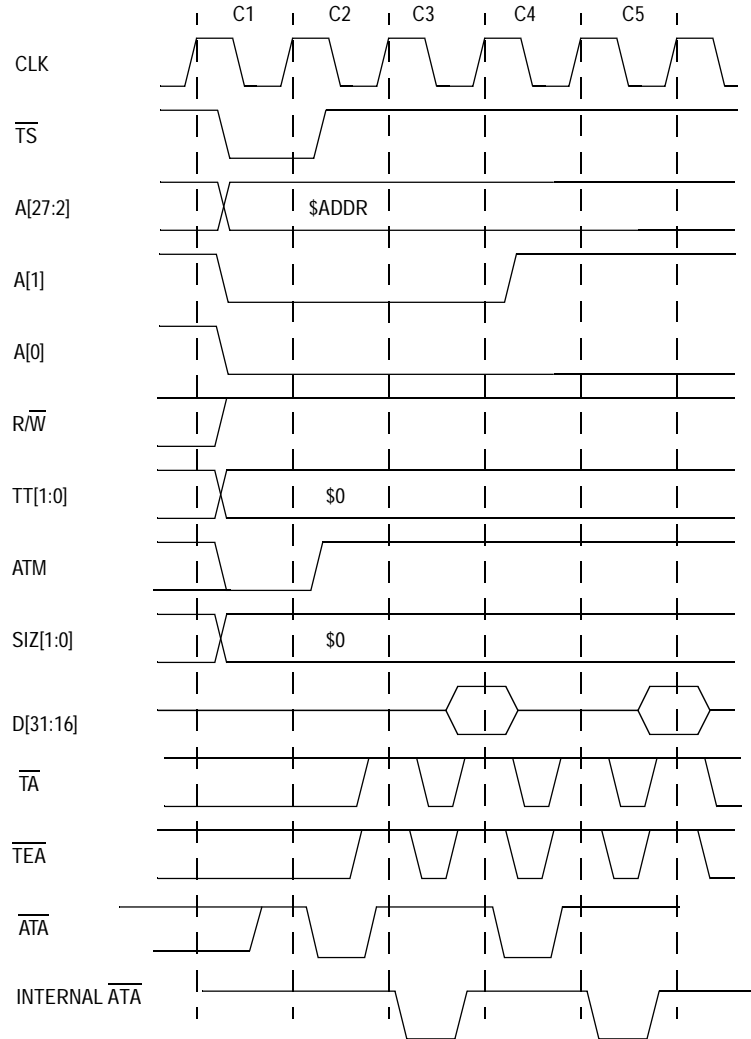

Figure 6-21. Bursting Longword-Read from 16-Bit Port Using Asynchronous Termination (One Wait State)

Clock 1 (C1)

The read cycle starts in C1. During C1, the MCF5206e places valid values on the address bus (A[27:0]) and transfer control signals. The transfer type (TT[1:0]) signals identify the specific access type and ATM identifies the transfer as reading data. The read/write ($\overline{R/W}$) signal is driven high for a read cycle, and the size signals (SIZ[1:0]) are driven to $\$0$ to indicate a longword transfer. The MCF5206e asserts \overline{TS} to indicate the beginning of a bus cycle.

Clock 2 (C2)

During C2, the MCF5206e negates \overline{TS} , drives \overline{ATM} high to identify the transfer as supervisor. The selected device(s) asserts \overline{ATA} prior to the falling edge of the clock.

Clock 3 (C3)

At the end of C3, the MCF5206e samples the level of internal asynchronous transfer acknowledge and if it is asserted, latches the current value of D[31:16]. If internal asynchronous transfer acknowledge is asserted, the transfer of the first word is complete. If internal asynchronous transfer acknowledge is negated, the MCF5206e continues to sample internal asynchronous transfer acknowledge and inserts wait states instead of terminating the transfer. The MCF5206e continues to sample internal asynchronous transfer acknowledge until it is asserted. As long as \overline{ATA} is asserted prior to the falling edge of C2, internal asynchronous transfer acknowledge is asserted by the rising edge of C3.

Clock 4 (C4)

The MCF5206e increments A[1:0] to address the next word. The selected device(s) asserts \overline{ATA} prior to the falling edge of the clock.

Clock 5 (C5)

At the end of C5, the MCF5206e samples the level of internal asynchronous transfer acknowledge and if it is asserted, latches the current value of D[31:16]. If internal asynchronous transfer acknowledge is asserted, the transfer of the second word is complete and the transfer is terminated. If internal asynchronous transfer acknowledge is negated, the MCF5206e continues to sample internal asynchronous transfer acknowledge and inserts wait states instead of terminating the transfer. The MCF5206e continues to sample internal asynchronous transfer acknowledge until it is asserted. As long as \overline{ATA} is asserted prior to the falling edge of C4, internal asynchronous transfer acknowledge is asserted by the rising edge of C5.

6.5.9 Bursting Write Transfers: Word, Longword, and Line with Asynchronous Acknowledge

Figure 6-22 is a flowchart for bursting write transfers (four transfers long) to 8-, 16-, or 32-bit ports using asynchronous termination. Bus operations are similar for each case and vary only with the size indicated, the portion of the data bus used for the transfer, and the specific number of cycles needed for each transfer. A bursted transfer can be from two to 16 transfers long.

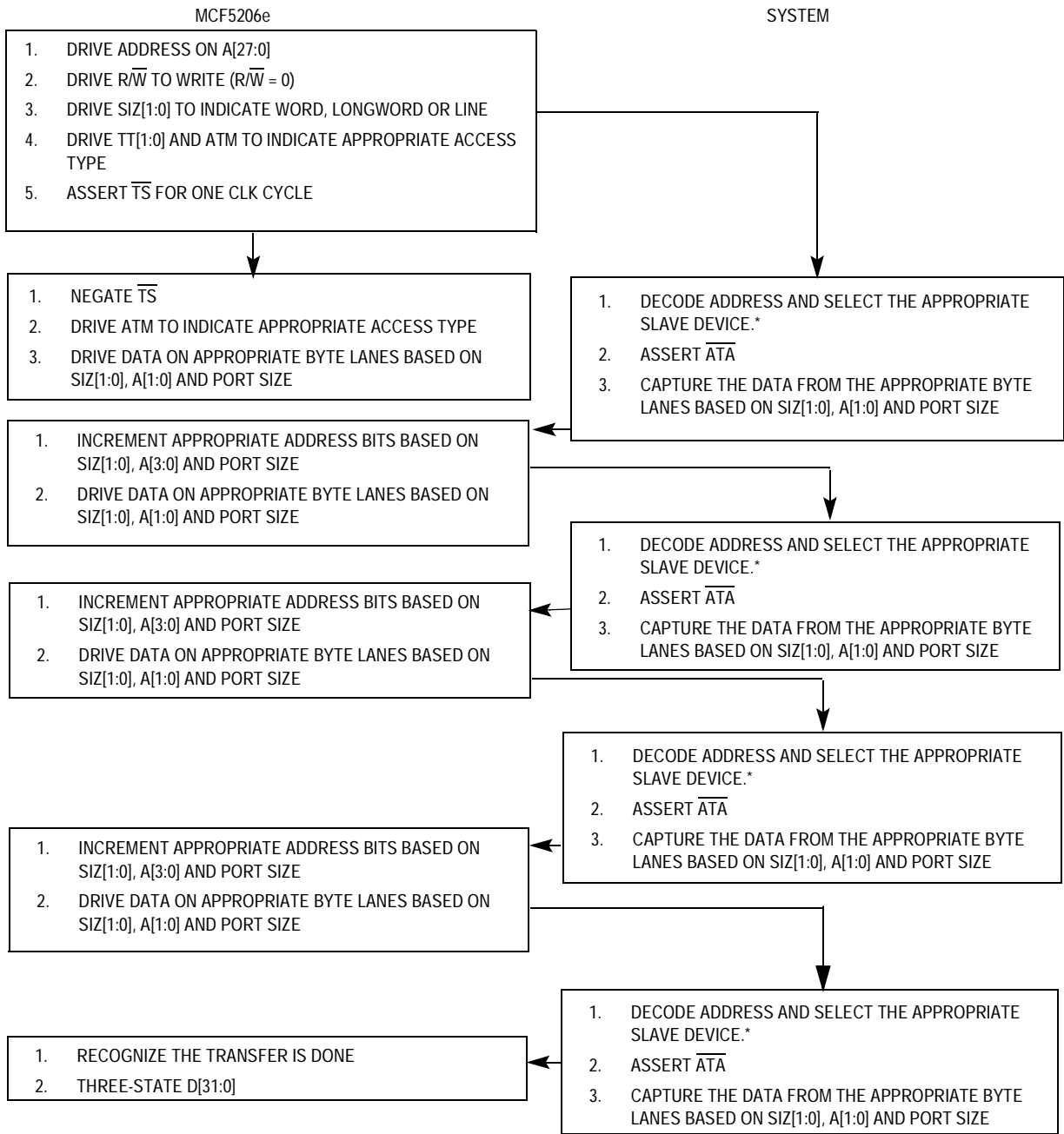

*TO INSERT WAIT STATES, \overline{ATA} IS DRIVEN NEGATED.

Figure 6-22. Word-, Longword-, and Line-Write Transfer Flowchart with Asynchronous Termination

Figure 6-23 shows a bursting user data line-write transfer to a 32-bit port using asynchronous termination.

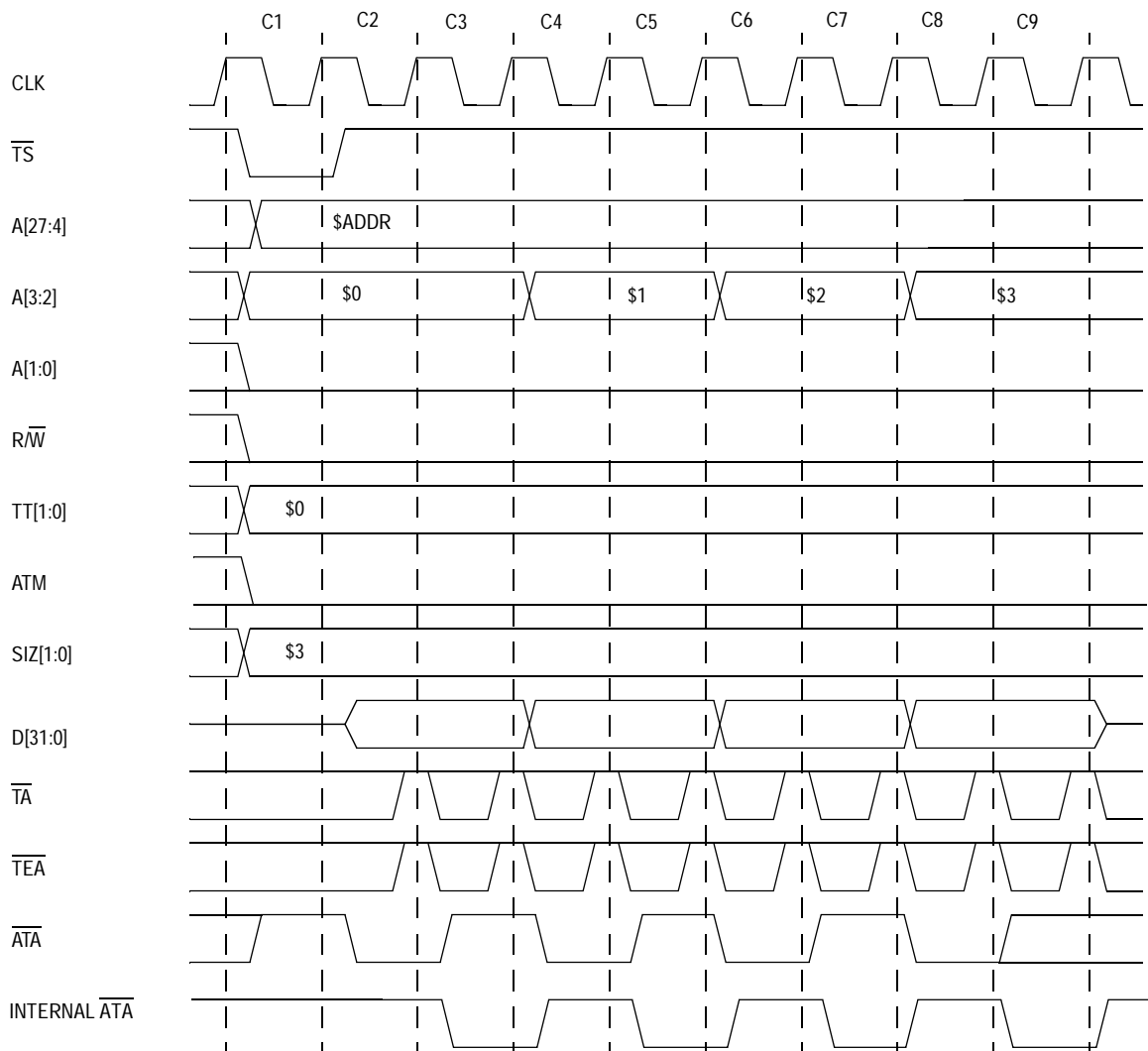

Figure 6-23. Bursting Line-Write from 32-Bit Port Using Asynchronous Termination (One Wait State)

Clock 1 (C1)

The write cycle starts in C1. During C1, the MCF5206e places valid values on the address bus (A[27:0]) and transfer control signals. The transfer type (TT[1:0]) signals identify the specific access type and ATM identifies the transfer as data. The read/write (R/W) signal is driven low for a write cycle, and the size signals (SIZ[1:0]) are driven to \$3 to indicate a line transfer. The MCF5206e asserts \overline{TS} to indicate the beginning of a bus cycle.

Clock 2 (C2)

During C2, the MCF5206e negates \overline{TS} , drives ATM low to identify the transfer as user and places the data on the data bus (D[31:0]). The selected device(s) asserts \overline{ATA} if it is ready to latch the data, which is recognized by the MCF5206e on the next falling clock edge.

Clock 3 (C3)

If the selected device asserted asynchronous transfer acknowledge during C2, the selected device must latch the data by the end of C3. At the end of C3, the MCF5206e samples the level of internal asynchronous transfer acknowledge. If internal asynchronous transfer acknowledge is asserted, the transfer of the first longword is complete. If internal asynchronous transfer acknowledge is negated, the MCF5206e continues to sample internal asynchronous transfer acknowledge and inserts wait states instead of terminating the transfer. The MCF5206e continues to sample internal asynchronous transfer acknowledge until it is asserted. As long as \overline{ATA} is asserted prior to the falling edge of C2, the internal asynchronous transfer acknowledge is asserted by the rising edge of C3.

Clock 4 (C4)

The MCF5206e increments A[3:2] to address the next longword of the line transfer and drives D[31:0] with the second longword of data. The selected device(s) asserts \overline{ATA} if it is ready to latch the data. At the end of C4, the MCF5206e samples the level of internal \overline{ATA} and if it is asserted, the second longword transfer of the line write is complete. If internal \overline{ATA} is negated, the MCF5206e continues to sample internal \overline{ATA} and inserts wait states instead of terminating the transfer. The MCF5206e continues to sample internal \overline{ATA} on successive falling edges of the CLK until it is asserted.

Clock 5 (C5)

This clock is identical to C3 except that the data value corresponds to the second longword of data for the burst.

Clock 6 (C6)

This clock is identical to C4 except that once internal \overline{ATA} is asserted, the address and the data values correspond to the third longword of data for the burst.

Clock 7 (C7)

This clock is identical to C3 except that the data value corresponds to the third longword of data for the burst.

Clock 8 (C8)

This clock is identical to C4 except that once internal \overline{ATA} is asserted the address and data value correspond to the fourth longword of data for the burst.

Clock 9 (C9)

This clock is identical to C3 except that the data value corresponds to the fourth longword of data for the line. This is the last CLK cycle of the line write transfer and the MCF5206e three-states D[31:0] at the start of the next CLK cycle.

6.5.10 Burst-Inhibited Read Transfers: Word, Longword, and Line with Asynchronous Acknowledge

If the burst-enable bit is cleared in the appropriate Chip Select Control Register (CSCR) or Default Memory Control Register (DMCR) and the operand size is larger than the port size of the memory being accessed, the MCF5206e performs word, longword, and line transfers in burst-inhibited mode. When burst-inhibit mode is selected, the size of the transfer (indicated by SIZ[1:0]) reflects the port size if the operand being read is larger than the port size, or the operand size if the port size is larger than the operand size. A transfer size of line (SIZ[1:0] = \$3) is never indicated in burst-inhibited mode. If the operand size is line, the size pins (SIZ[1:0]) always indicates the port size.

The basic transfer of a burst-inhibited read using asynchronous termination is the same as “normal” read using asynchronous termination with the addition of more transfers, until the entire operand has been accessed. Figure 6-24 is a flowchart for burst-inhibited read transfers to 8-, 16-, or 32-bit ports with asynchronous termination. Bus operations are similar for each case and vary only with the size indicated, the portion of the data bus used for the transfer, and the specific number of cycles needed for each transfer. The flowchart is specifically for a burst-inhibited transfer of four transfers long.

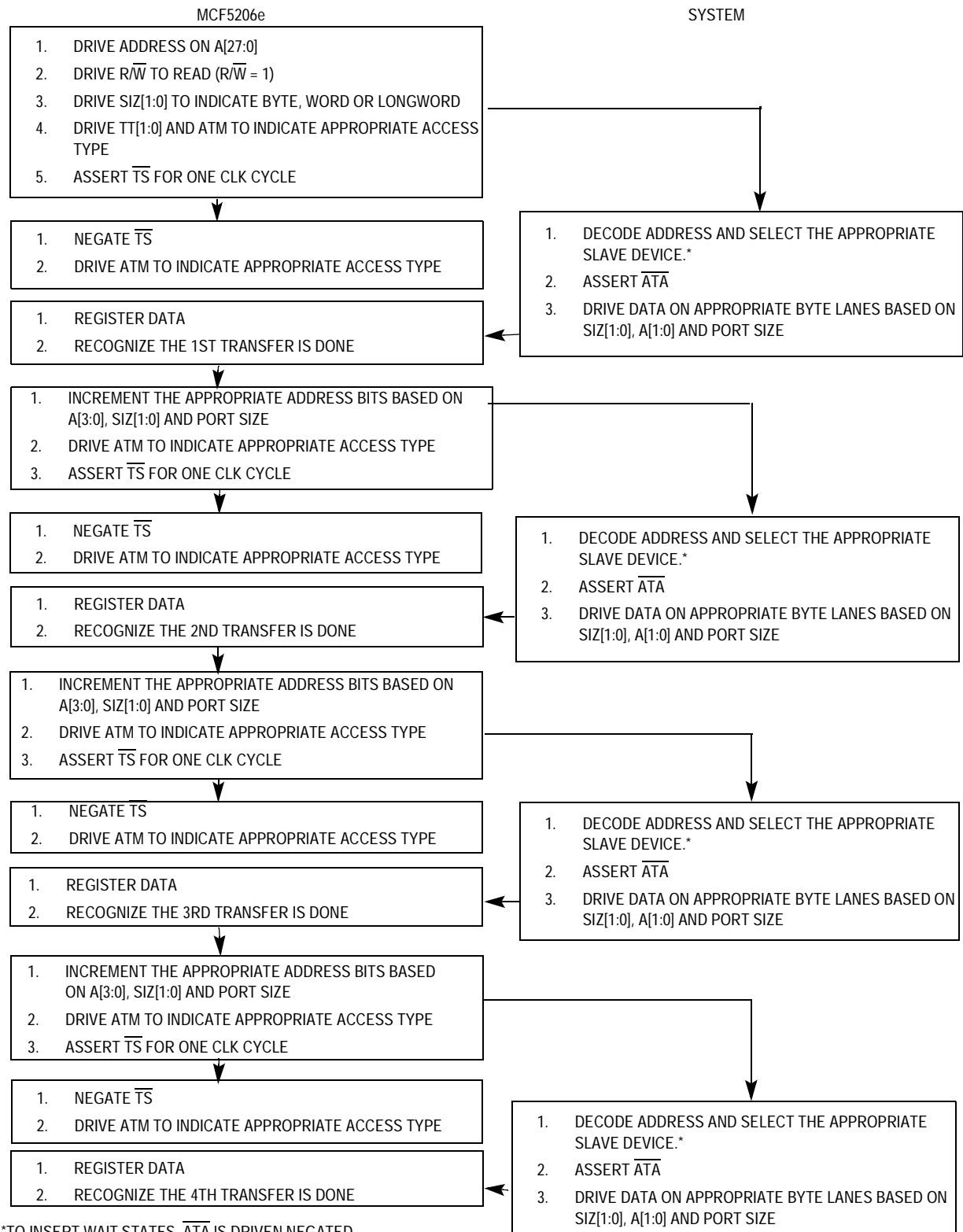

Figure 6-24. Burst-Inhibited Word-, Longword-, and Line-Read Transfer with Asynchronous Termination Flowchart

Figure 6-25 shows a burst-inhibited user code word-read transfer from an 8-bit port.

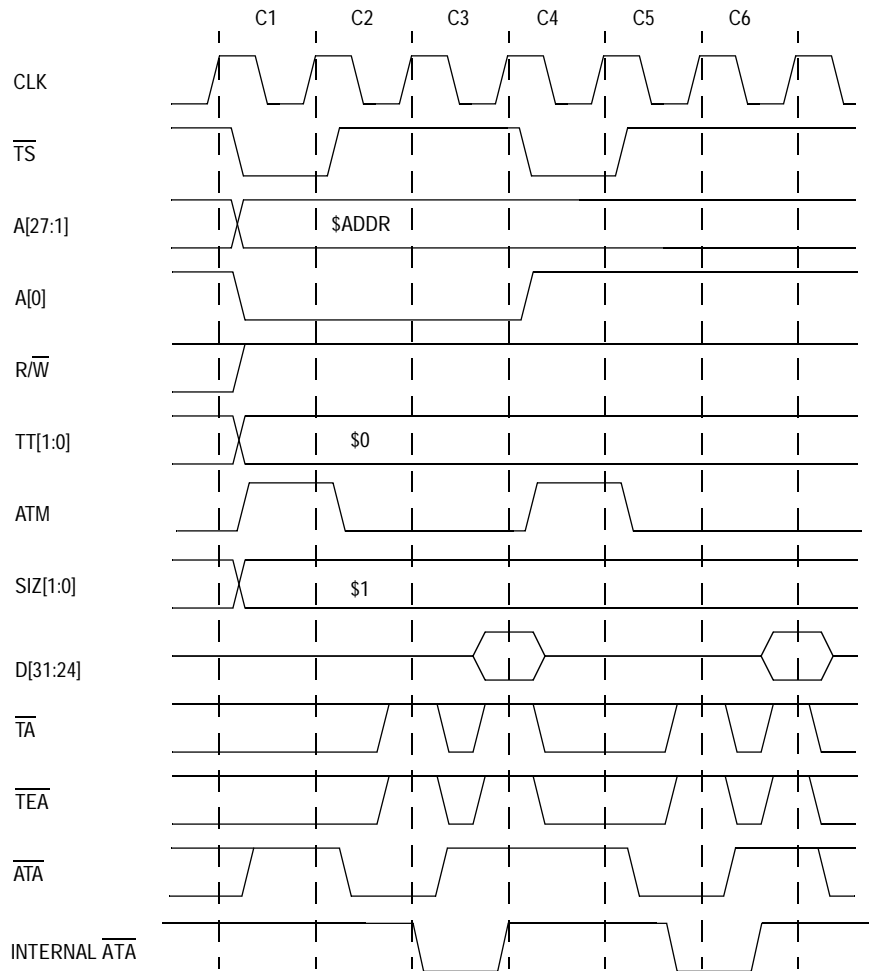

Figure 6-25. Burst-Inhibited Word Read from 8-Bit Port Using Asynchronous Termination

Clock 1 (C1)

The read cycle starts in C1. During C1, the MCF5206e places valid values on the address bus (A[27:0]) and transfer control signals. The transfer type (TT[1:0]) signals identify the specific access type and ATM identifies the transfer as code. The read/write (R/W) signal is driven high for a read cycle and the size signals (SIZ[1:0]) are driven to \$1 to indicate a byte transfer. The MCF5206e asserts TS-bar to indicate the beginning of a bus cycle.

Clock 2 (C2)

During C2, the MCF5206e negates TS-bar, drives ATM low to identify the transfer as user. The selected device(s) asserts ATA, which is recognized at the next falling clock edge.

Clock 3 (C3)

At the end of C3, the MCF5206e samples the level of internal asynchronous transfer acknowledge and if it is asserted, latches the current value of D[31:24]. If internal asynchronous transfer acknowledge is asserted, the transfer of the first byte is complete. If internal asynchronous transfer acknowledge is negated, the MCF5206e continues to sample internal asynchronous transfer acknowledge and inserts wait states instead of terminating the transfer. The MCF5206e continues to sample internal asynchronous transfer acknowledge until it is asserted. As long as \overline{ATA} is asserted prior to the falling edge of C2, internal asynchronous transfer acknowledge is asserted by the rising edge of C3.

Clock 4 (C4)

This clock is identical to C1 except the address bus is incremented to point to the second byte of data.

Clock 5 (C5)

This clock is identical to C2.

Clock 6 (C6)

This clock is identical to C3 except once internal \overline{ATA} is recognized, the data corresponds to the second byte of data.

6.5.11 Burst-Inhibited Write Transfers: Word, Longword, and Line with Asynchronous Acknowledge

The basic transfer of a burst-inhibited write using asynchronous termination is the same as “normal” write transfers with asynchronous termination but with the addition of more transfers until the entire operand has been accessed. Figure 6-26 is a flowchart for burst-inhibited write transfers to 8-, 16-, or 32-bit ports using asynchronous termination. Bus operations are similar for each case and vary only with the size indicated, the portion of the data bus used for the transfer, and the specific number of cycles needed for each transfer. The flowchart specifically depicts a burst-inhibited transfer of four accesses long.

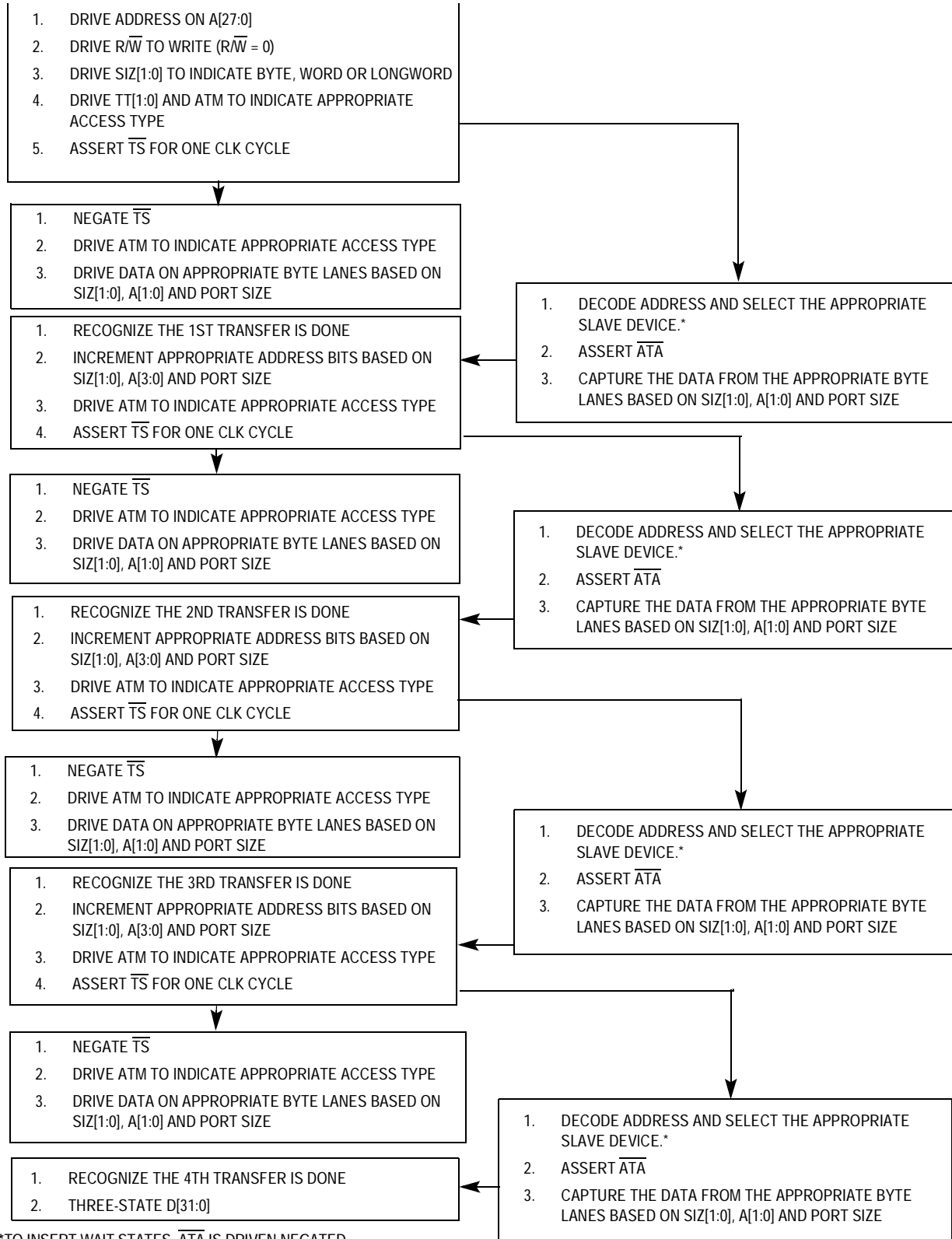

Figure 6-26. Burst-Inhibited Word-, Longword-, and Line-Write Transfer with Asynchronous Termination Flowchart

Figure 6-27 shows a burst-inhibited supervisor data longword-write transfer to a 16-bit port.

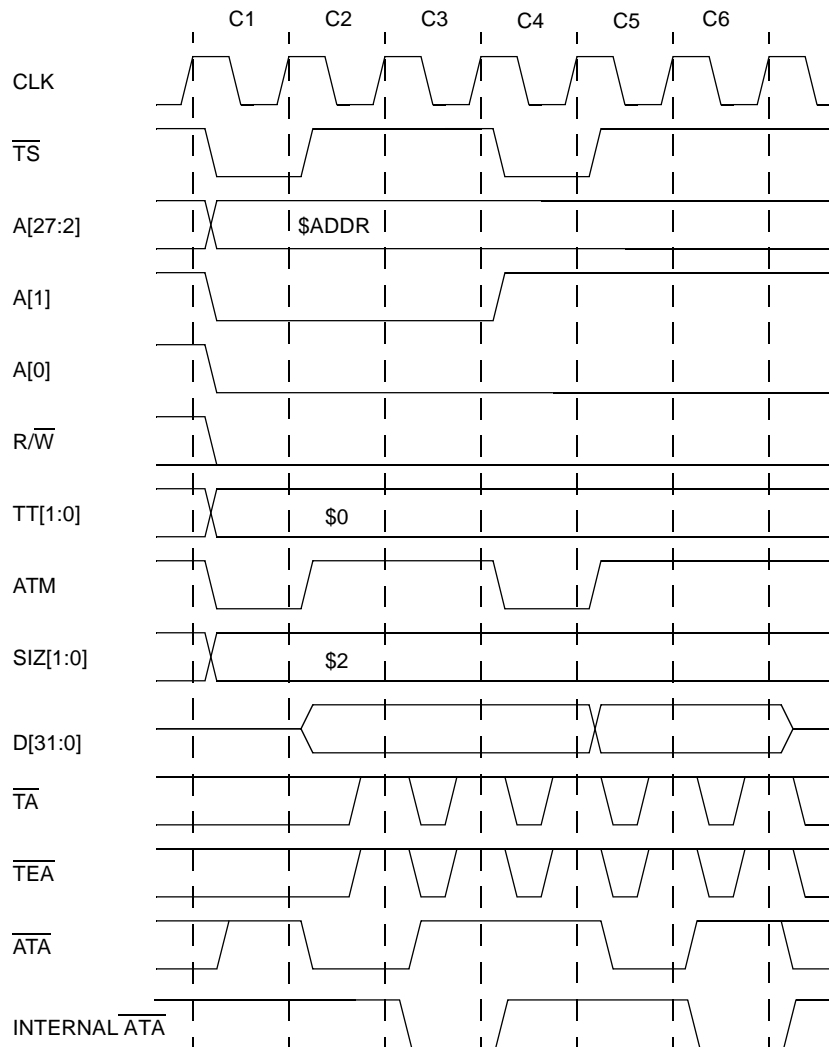

Figure 6-27. Burst-Inhibited Longword-Write Transfer to 16-Bit Port Using Asynchronous Termination (One Wait State)

Clock 1 (C1)

The write cycle starts in C1. During C1, the MCF5206e places valid values on the address bus (A[27:0]) and transfer control signals. The transfer type (TT[1:0]) signals identify the specific access type and ATM identifies the transfer as data. The read/write (R/W) signal is driven low for a write cycle, and the size signals (SIZ[1:0]) are driven to \$2 to indicate a word transfer. The MCF5206e asserts TS to indicate the beginning of a bus cycle.

Clock 2 (C2)

During C2, the MCF5206e negates \overline{TS} , drives \overline{ATM} high to identify the transfer as supervisor and drives the data on the data bus (D[31:0]). The selected device(s) asserts \overline{ATA} if it is ready to latch the data.

Clock 3 (C3)

At the end of C3, the MCF5206e samples the level of internal asynchronous transfer acknowledge and if it is asserted, terminates the first word transfer. If internal asynchronous transfer acknowledge is asserted, the transfer of the first word is complete. If internal asynchronous transfer acknowledge is negated, the MCF5206e continues to sample internal asynchronous transfer acknowledge and inserts wait states instead of terminating the transfer. The MCF5206e continues to sample internal asynchronous transfer acknowledge until it is asserted. As long as \overline{ATA} is asserted by the falling edge of C2, the rising edge of C3 asserts the internal asynchronous transfer acknowledge.

Clock 4 (C4)

This clock is identical to C1 except the MCF5206e increments the address to indicate the next word.

Clock 5 (C5)

This clock is identical to C2 except that the data driven corresponds to the second word of data.

Clock 6 (C6)

This clock is identical to C3 except after asynchronous transfer acknowledge is recognized, the MCF5206e three-states the data bus after the next rising edge of CLK.

6.5.12 Termination Tied to GND

If the MCF5206e is in a system with multiple masters and you require zero wait-state operation, you can tie \overline{ATA} to GND to achieve zero wait-state operation for nonDRAM transfers. \overline{ATA} must be used in this case as the MCF5206e can drive \overline{TA} during external master accesses. When \overline{ATA} is tied to GND, all nonDRAM transfers follow the timing shown with \overline{TA} asserted with zero wait states.

If the MCF5206e is the only master in the system, \overline{TA} and \overline{BG} can be tied to GND to grant mastership of the external bus to the MCF5206e and achieve zero wait-state operation.

NOTE

\overline{TA} cannot be tied to GND if the MCF5206e is not the only bus master in the system. Damage to the part could occur if \overline{TA} is tied to GND and external master accesses using 5206e generated termination.

6.6 MISALIGNED OPERANDS

All MCF5206e data formats can be located in memory on any byte boundary. A byte operand is properly aligned at any address; a word operand is misaligned at an odd address; and a longword is misaligned at an address that is not evenly divisible by four. However, because operands can reside at any byte boundary, they can be misaligned. Although the MCF5206e does not enforce any alignment restrictions for data operands (including program counter (PC) relative data addressing), some performance degradation occurs when additional bus cycles are required for longword or word operands that are misaligned. For maximum performance, data items should be aligned on their natural boundaries. All instruction words and extension words must reside on word boundaries. An address error exception occurs with any attempt to prefetch an instruction word at an odd address.

The MCF5206e converts misaligned operand accesses that are noncacheable to a sequence of aligned accesses. Figure 6-28 illustrates the transfer of a longword operand from a byte address to a 32-bit port, requiring more than one bus cycle. In this example, the SIZ[1:0] signals specify a byte transfer, and the byte offset of \$1. The slave device supplies the byte and acknowledges the data transfer. When the MCF5206e starts the second cycle, the SIZ[1:0] signals specify a word transfer with a byte offset of \$2. The next two bytes are transferred during this cycle. The MCF5206e then initiates the third cycle, with the SIZ[1:0] signals indicating a byte transfer. The byte offset is now \$0; the port supplies the final byte and the operation is complete. Figure 6-29 is similar to the example illustrated in Figure 6-28 except that the operand is word-sized and the transfer requires only two bus cycles.

	31	24 23	16 15	8 7	0
TRANSFER 1	-	OP 3	-	-	
TRANSFER 2	-	-	OP 2	OP 1	
TRANSFER 3	OP 0	-	-	-	

Figure 6-28. Example of a Misaligned Longword Transfer

	31	24 23	16 15	8 7	0
TRANSFER 1	-	-	-	OP 1	
TRANSFER 2	OP 0	-	-	-	

Figure 6-29. Example of a Misaligned Word Transfer

NOTE

External masters that are using internal MCF5206e chip selects, DRAM, and default memory control signals must initiate aligned transfers only.

6.7 ACKNOWLEDGE CYCLES

When a peripheral device requires the services of the MCF5206e or is ready to send information that the ColdFire core requires, it can signal the ColdFire core to take an interrupt exception. The interrupt exception transfers control to a routine that responds appropriately. The peripheral device uses the interrupt priority level/interrupt request signals (IPLx/IRQx) to signal an interrupt condition to the MCF5206e.

The MCF5206e has two levels of interrupt masking. The first level of interrupt masking is in the interrupt controller in the System Integration Module (SIM) which masks individual interrupt inputs and then outputs the interrupt priority level of the highest pending unmasked interrupt to the ColdFire core. The Status Register (SR) provides the second level of interrupt masking in the ColdFire core. The value of the SR interrupt mask is the highest priority level that the ColdFire core ignores. When an interrupt request has a priority higher than the value in the mask, the ColdFire core makes the request a pending interrupt. For more information about the Status Register refer to **Section 3.2.2.1 Status Register** in the ColdFire Core Section.

The MCF5206e continuously samples the external interrupt input signals and synchronizes and debounces these signals. An interrupt request must be held constant for at least two consecutive CLK periods to be considered a valid input. If the external interrupt inputs are programmed to individual interrupt requests (at level 1, 4, and 7), the interrupt request must maintain the interrupt request level until the MCF5206e acknowledges the interrupt to guarantee that the interrupt is recognized. If the external interrupt inputs are programmed to be interrupt priority levels, the interrupt request must maintain the interrupt request level or a higher priority level until the MCF5206e acknowledges the interrupt to guarantee that the interrupt is recognized.

NOTE

All interrupts are level sensitive only. Interrupts must remain stable and held valid for the interrupt to be detected.

The MCF5206e takes an interrupt exception for a pending interrupt within one instruction boundary after processing any other pending exception with a higher priority. Thus, the MCF5206e executes at least one instruction in an interrupt exception handler before recognizing another interrupt request.

If the AVEC bit in the Interrupt Control Register (ICR) for the interrupt being acknowledged is set to 1 (enabling autovectoring), the interrupt acknowledge vector is generated internally and no interrupt acknowledge cycle is generated on the external bus. Refer to the SIM section **7.3.2.3 Interrupt Control Register** for ICR programming.

NOTE

If autovector generation is used for external interrupts, no interrupt acknowledge cycle is generated on the external bus. Consequently, the user must clear the external interrupt in the interrupt service routine.

6.7.1 Interrupt Acknowledge Cycle

When the MCF5206e processes an interrupt exception, it performs an interrupt acknowledge bus cycle to obtain the vector number that contains the starting location of the interrupt exception handler.

The interrupt acknowledge bus cycle is a read transfer. It differs from a normal read cycle in the following respects:

- TT[1:0] = \$3 to indicate a CPU space/acknowledge bus cycle
- ATM = \$1 when \overline{TS} is asserted and ATM = \$0 when \overline{TS} is negated
- Address signals A[27:5] are set to all ones (\$7FFFFFFF)
- Address signals A[4:2] are set to the interrupt request level being acknowledged
- Address signals A[1:0] are set to all zeros (\$0)

The responding device places the vector number on D[31:24] of the data bus during the interrupt acknowledge bus cycle and the cycle is terminated normally with \overline{TA} or ATA. Figure 6-30 and Figure 6-31 illustrate a flowchart and functional timing diagram for an interrupt-acknowledge cycle terminated with \overline{TA} .

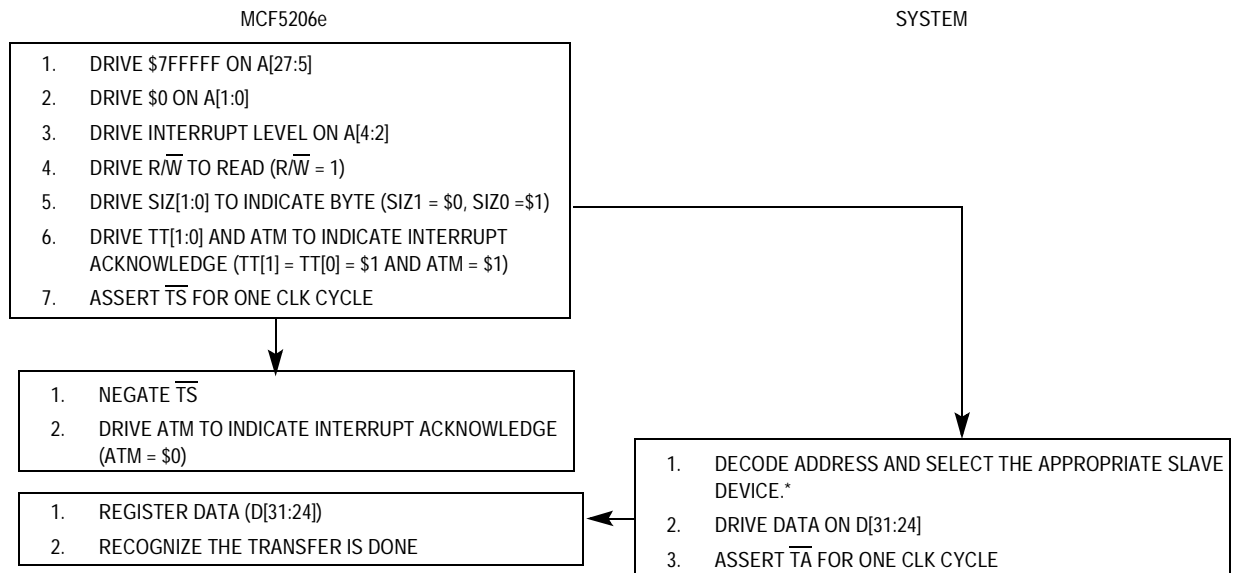

Figure 6-30. Interrupt-Acknowledge Cycle Flowchart

Figure 6-31 shows an interrupt acknowledge cycle.

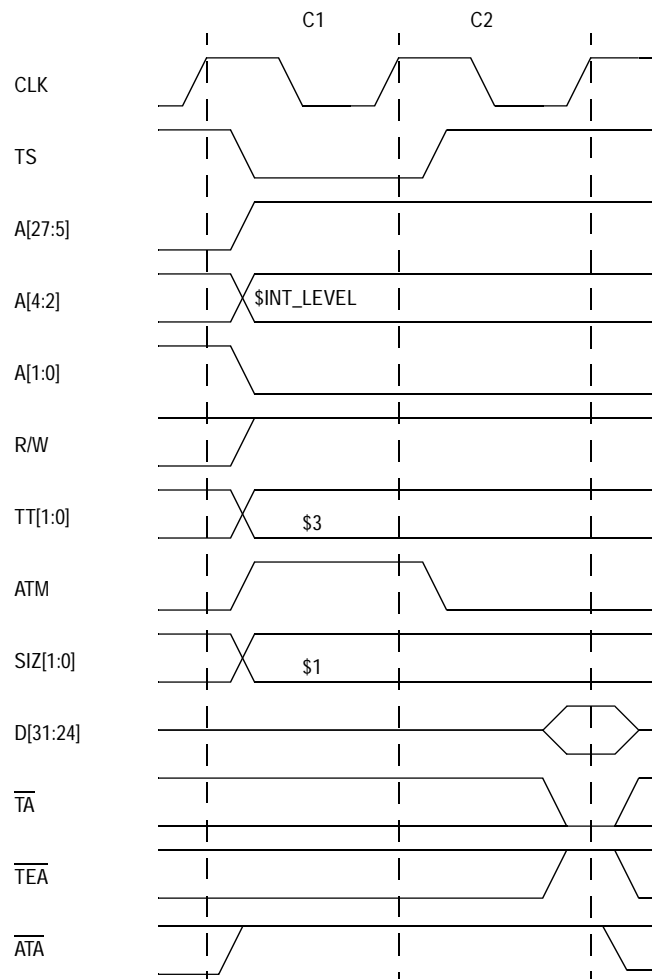

Figure 6-31. Interrupt Acknowledge Bus Cycle Timing (No Wait States)

Clock 1 (C1)

The interrupt acknowledge cycle starts in C1. During C1, the MCF5206e places valid values on the address bus (A[27:0]) and transfer control signals. The address bus is driven with \$7FFFFFFF on A[27:5], \$0 on A[1:0] and the interrupt level being acknowledged on A[4:2]. The transfer type (TT[1:0]) signals are driven to \$3 and the ATM is driven high to identify the access as an interrupt acknowledge cycle. The read/write (R/W) signal is driven high for a read cycle, and the size signals (SIZ[1:0]) are driven to \$1 to indicate a byte transfer. The MCF5206e asserts \overline{TS} to indicate the beginning of a bus cycle.

Clock 2 (C2)

During C2, the MCF5206e negates transfer start (\overline{TS}), drives access type and mode (ATM) low to identify the transfer as an interrupt acknowledge cycle. The selected

device(s) places the interrupt vector number onto $D[31:24]$ and asserts \overline{TA} . At the end of C2, the MCF5206e samples the level of \overline{TA} and if \overline{TA} is asserted, latches the current value of $D[31:24]$ which contains the interrupt vector number. If \overline{TA} is asserted, the transfer of the interrupt vector is complete and the transfer terminates. If \overline{TA} is negated, the MCF5206e continues to sample \overline{TA} and inserts wait states instead of terminating the transfer. The MCF5206e continues to sample \overline{TA} on successive rising edges of CLK until it is asserted.

NOTE

Interrupt acknowledge cycles can be asynchronously acknowledged using \overline{ATA} . As long as \overline{ATA} is asserted by the falling edge of C2, internal asynchronous transfer acknowledge is asserted by the rising edge of C3. The interrupt vector must remain driven on $D[31:24]$ until internal asynchronous transfer acknowledge is asserted.

6.8 BUS ERRORS

The system hardware can use the transfer error acknowledge (\overline{TEA}) signal to abort the current bus cycle when a fault is detected. A bus error is recognized during a bus cycle when \overline{TEA} is asserted.

When the MCF5206e recognizes a bus error condition for an access, the access is terminated immediately. An access that requires more than one transfer, aborts without completing the remaining transfers if \overline{TEA} is asserted, regardless of whether the access uses burst or burst-inhibited transfers.

Figure 6-32 shows a bursting supervisor code longword-read access from a 16-bit port with a transfer error.

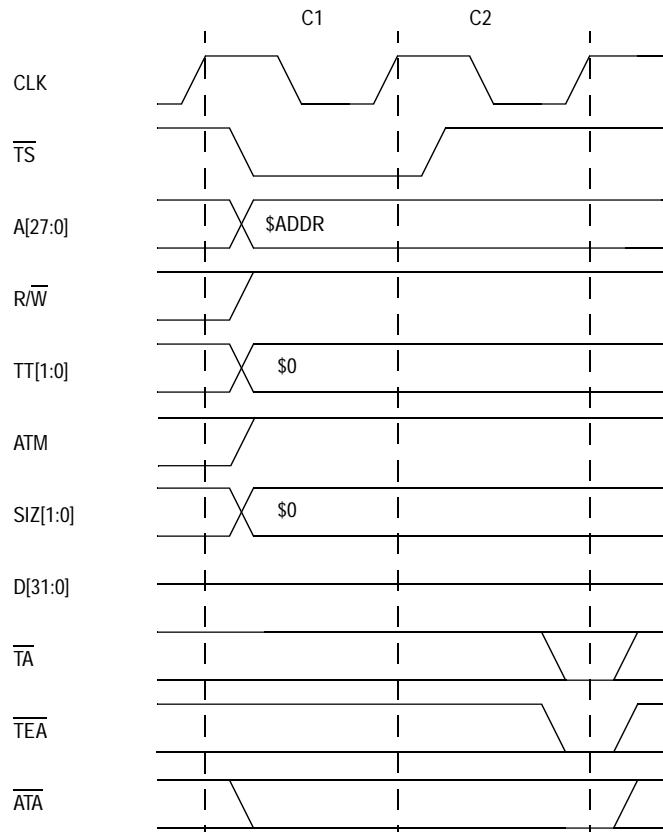

Figure 6-32. Bursting Longword-Read Access from 16-Bit Port Terminated with \overline{TEA} Timing

Clock 1 (C1)

The read cycle starts in C1. During C1, the MCF5206e places valid values on the address bus (A[27:0]) and transfer control signals. The transfer type (TT[1:0]) signals identify the specific access type and ATM identifies the transfer as code. The read/write (R/W) signal is driven high for a read cycle, and the size signals (SIZ[1:0]) are driven to \$0 to indicate a longword transfer. The MCF5206e asserts transfer start (\overline{TS}) to indicate the beginning of a bus cycle.

Clock 2 (C2)

During C2, the MCF5206e negates \overline{TS} , drives ATM high to identify the transfer as supervisor. The selected device detects an error and asserts TEA. At the end of C2, the MCF5206e samples the level of \overline{TEA} . If it is asserted, the transfer of the longword is aborted and the transfer terminates.

NOTE

If \overline{TA} is asserted when transfer error-acknowledge (\overline{TEA}) is asserted, the transfer is terminated with a bus error.

NOTE

For the MCF5206e to accept the transfer as successful with an \overline{ATA} , \overline{TEA} must be negated until the internal asynchronous transfer acknowledge is asserted or the transfer is completed with a bus error.

6.9 BUS ARBITRATION

The MCF5206e bus protocol provides for one bus master at a time: either the MCF5206e or an external device. If more than one external bus master is connected to the bus, an external arbiter can prioritize requests and determine which device is granted access to the bus. Bus arbitration is the protocol by which the MCF5206e or an external device becomes the bus master. When the MCF5206e is the bus master, it uses the bus to read instructions and transfer data not contained in its internal cache or memory to and from external memory. When an external bus master owns the bus, the MCF5206e can monitor the external bus master's transfers and assert chip select and DRAM control, and transfer termination signals. This capability is discussed in more detail in **Section 6.10 External Bus Master Operation**.

The MCF5206e bus arbitration can be used in two modes. A two-wire mode is provided for systems where the MCF5206e and a single external bus master are the only two masters arbitrating for use of the external bus. This arbitration mode uses the bus grant (\overline{BG}) and bus driven (\overline{BD}) signals. The bus request (\overline{BR}) signal can be ignored by the external bus master.

The second mode is provided for systems where multiple external bus masters are arbitrating for use of the external bus. This arbitration mode requires an external bus arbiter and uses the bus grant (\overline{BG}), bus driven (\overline{BD}) and bus request (\overline{BR}) signals to control usage of the external bus.

In either arbitration mode, the bus arbitration unit in the MCF5206e operates synchronously and transitions between states on the rising edge of CLK.

For systems where the MCF5206e is the only possible bus master, the bus can be continuously granted to the MCF5206e by tying bus grant (\overline{BG}) to GND. An arbiter is not required.

6.9.1 Two Master Bus Arbitration Protocol (Two-Wire Mode)

The two-wire mode of bus arbitration allows the MCF5206e to share the external bus with a single external bus master without requiring an external bus arbiter. Figure 6-33 is a block diagram showing the MCF5206e connecting to an external bus master using the

two-wire mode. In this mode, the active-low bus grant (\overline{BG}) input of the MCF5206e is connected to the active-high HOLDREQ output of the external bus master and the active-low bus-driven (\overline{BD}) output of the MCF5206e is connected to the active-high HOLDACK input of the external bus master. Because the external bus master controls the assertion/negation of HOLDREQ, it controls when the MCF5206e is granted the bus, making the MCF5206e the lower priority master. You can program the bus lock (BL) bit in the SIM Configuration Register (SIMR) to a 1, instructing the MCF5206e to retain control of the external bus, even when bus grant (\overline{BG}) is negated. This lets you control the priority of the MCF5206e with respect to the external master when in two-wire mode.

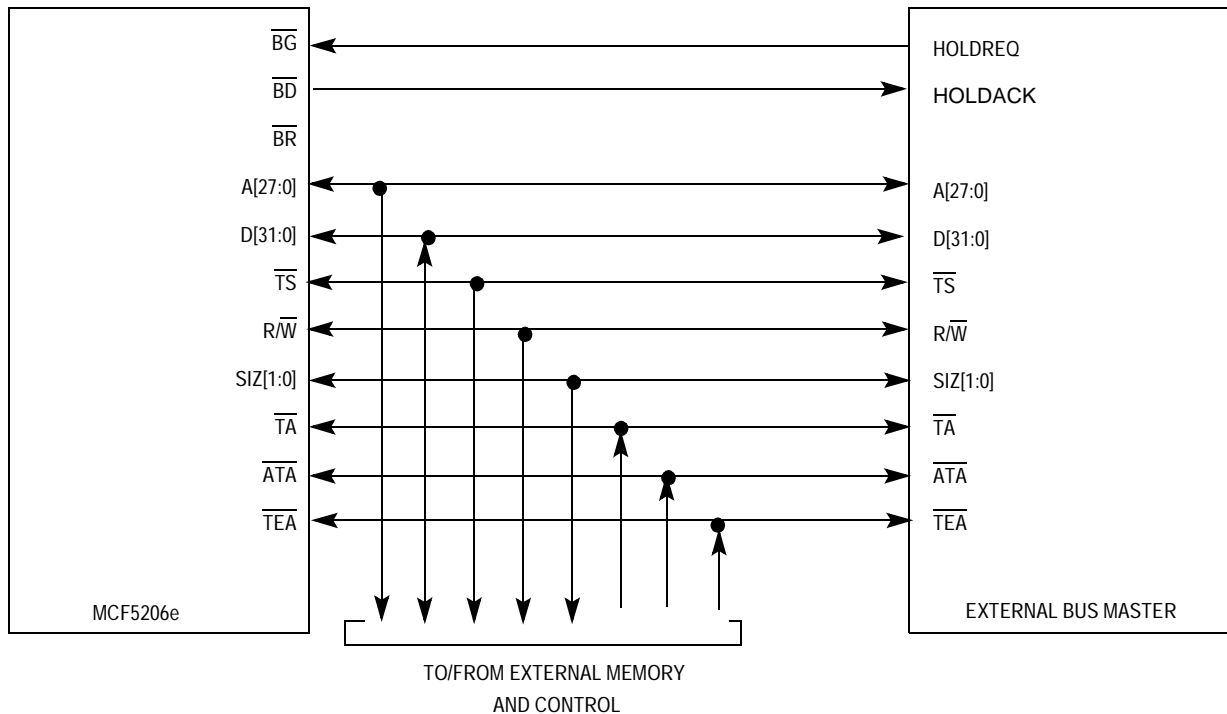

Figure 6-33. MCF5206e Two-Wire Mode Bus Arbitration Interface

When the external master is not using the bus, it negates HOLDREQ driving bus grant (\overline{BG}) low, granting the bus to the MCF5206e. When the MCF5206e has an internal bus request pending and bus grant (\overline{BG}) is low, the MCF5206e drives \overline{BD} low, negating HOLDACK to the external bus master. When the external bus master requires use of the external bus, it asserts HOLDREQ, driving bus grant (\overline{BG}) high, requesting the MCF5206e to relinquish the bus. If bus grant (\overline{BG}) is negated while a bus cycle is in progress and if the bus lock bit is cleared, the MCF5206e relinquishes the bus at the completion of the bus cycle. Note that the MCF5206e considers the individual transfers of a burst or burst-inhibited access to be a single bus cycle and does not relinquish the bus until the completion of the last transfer of the series.

When the bus has been granted to the MCF5206e, one of two situations can occur. In the first case, the MCF5206e has an internal bus request pending, the MCF5206e asserts \overline{BD} to indicate explicit bus ownership and begins the pending bus cycle by asserting \overline{TS} . The

MCF5206e continues to assert \overline{BD} until the completion of the bus cycle. If bus grant (\overline{BG}) is negated by the end of the bus cycle and the Bus Lock bit in the SIMR is 0, the MCF5206e negates \overline{BD} . As long as bus grant (\overline{BG}) is asserted, \overline{BD} remains asserted to indicate the bus is owned by the MCF5206e and the MCF5206e continuously drives the address bus, attributes and control signals.

In the second situation, the bus is granted to the MCF5206e, but the MCF5206e does not have an internal bus request pending and the Bus Lock bit in the SIMR is 0, so it takes implicit ownership of the bus. Implicit ownership of the bus occurs when the MCF5206e is granted the bus, but there are no pending bus cycles and the bus lock bit (BL) in the SIMR is set to 0. The MCF5206e does not drive the bus and does not assert bus driven \overline{BD} if the bus is implicitly owned. If an internal bus request is generated or the bus lock bit in the SIM Configuration Register (SIMR) is set to 1, the MCF5206e assumes explicit ownership of the bus. If explicit ownership was assumed because of an internal request being generated, the MCF5206e immediately begins an access and simultaneously asserts bus driven \overline{BD} and \overline{TS} . If explicit ownership was assumed because of the bus lock bit being set to 1, the MCF5206e asserts bus driven \overline{BD} and drives the address, attributes and control signals but does not assert \overline{TS} and does not begin a bus transfer.

In the case where the bus lock bit is set to 1, the MCF5206e is the explicit master of the external bus, but does not begin an access until an internal request is generated. Figure 6-34 illustrates implicit and explicit bus ownership because of the bus lock bit being set

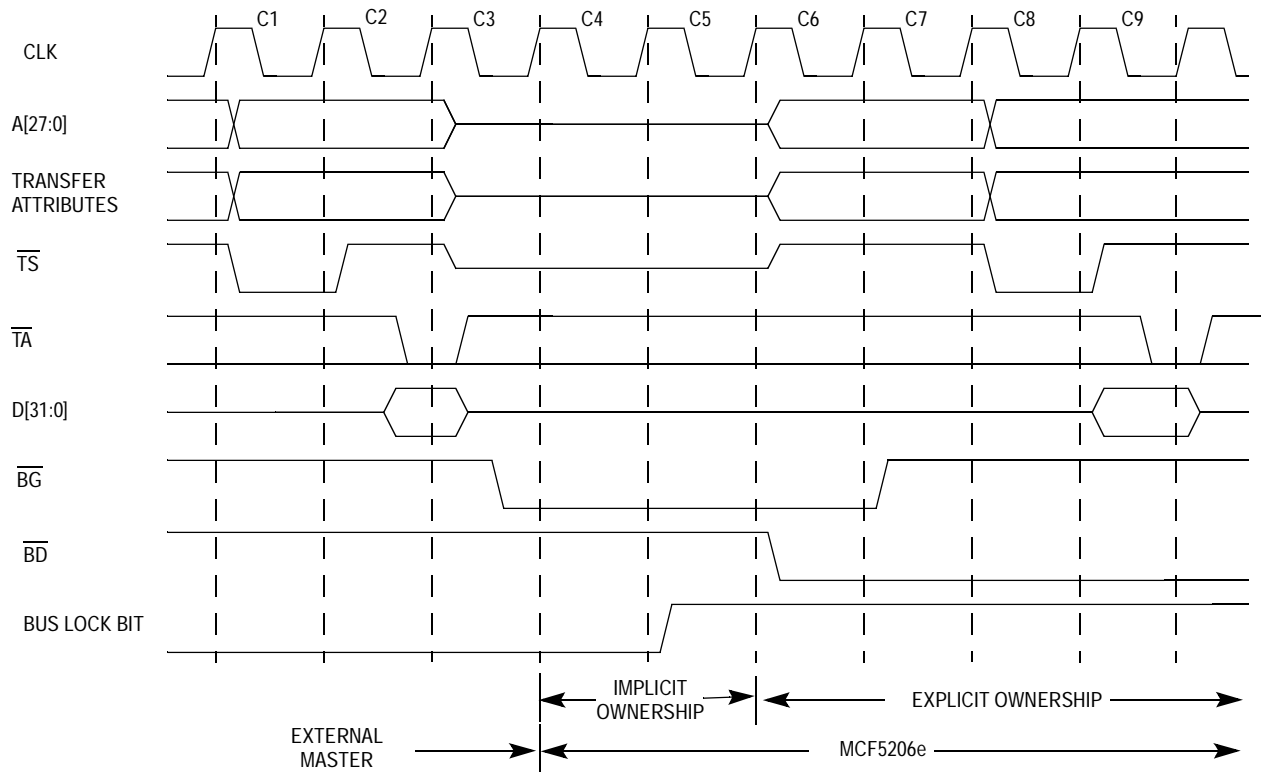

then an internal bus request being generated.

Figure 6-34. Two-Wire Implicit and Explicit Bus Ownership

In Figure 6-34, the external master has ownership of the external bus during Clock 1 (C1) and Clock 2 (C2). In Clock 3 (C3) the external master releases control of the bus by asserting bus grant (\overline{BG}) to the MCF5206e. During Clock 4 (C4) and Clock 5 (C5) the MCF5206e is implicit owner because an internal access is not pending and the bus lock bit is cleared. In C5, the bus lock bit is set to 1, causing the MCF5206e to take explicit ownership of the bus in Clock 6 (C6) by asserting \overline{BD} . In Clock 7 (C7) the external master removes the bus grant to the MCF5206e. Because the bus lock bit is set to 1, the MCF5206e does not relinquish the bus (the MCF5206e continues to assert \overline{BD}).

NOTE

The MCF5206e can start a transfer during the CLK cycle after \overline{BG} is asserted. The external master should not assert \overline{BG} to the MCF5206e until it has stopped driving the bus. \overline{BG} cannot be asserted while the external master transfer is still in progress or damage to the part could occur.

When the bus has been removed from the MCF5206e, one of two situations can occur. In the first case, the bus lock bit in the SIM Configuration Register (SIMR) is cleared and the MCF5206e has implicit ownership of the bus. When the external bus master negates \overline{BG} , the MCF5206e negates \overline{BD} and three-state the address, data, \overline{TS} , R/W, and SIZ signals after completing the current bus cycle. Figure 6-35 illustrates two-wire bus arbitration with the bus lock bit cleared.

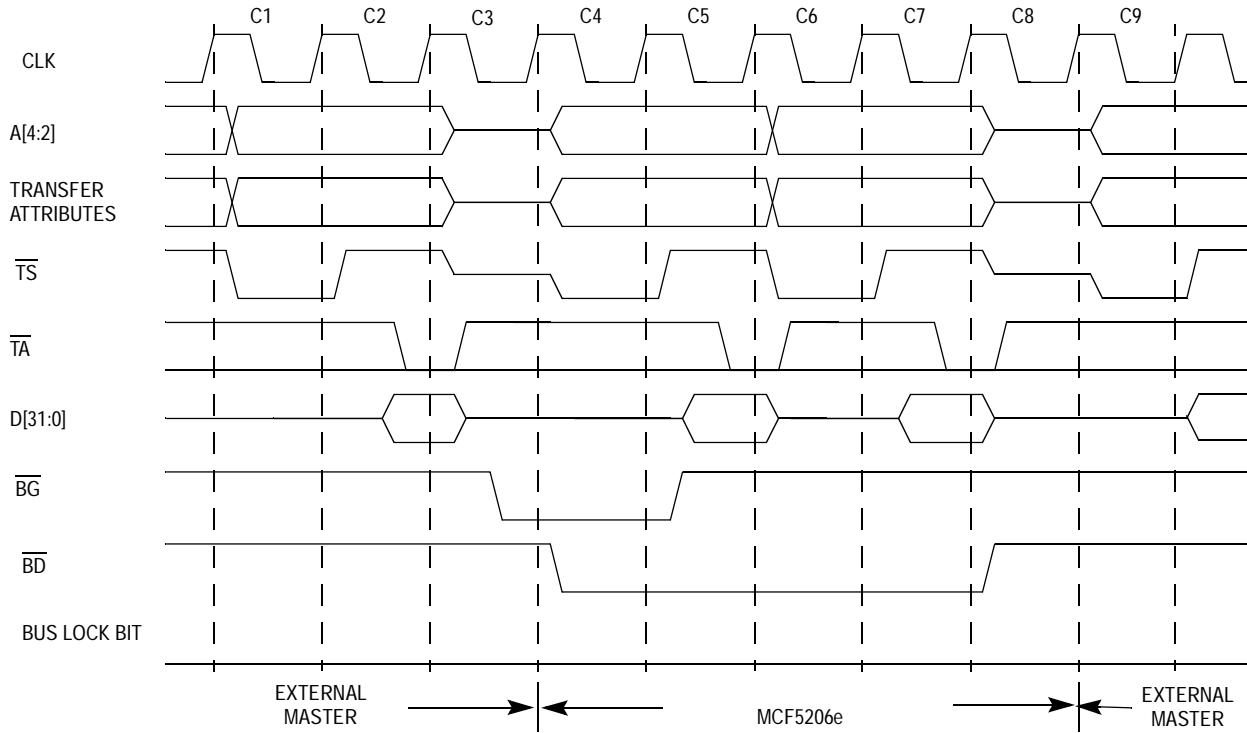

Figure 6-35. Two-Wire Bus Arbitration with Bus Lock Negated

In Figure 6-35 during clocks C1 and C2, the external master is the bus owner. During C3, the external master relinquishes control of the bus by asserting \overline{BG} to the MCF5206e. At this point, the bus lock bit is cleared, but because there is an internal access pending, the MCF5206e asserts \overline{BD} during C4 and begins the access. Thus, the MCF5206e becomes the explicit master of the external bus. This access is a burst-inhibited access. During C5, the external master removes the grant from the MCF5206e by negating \overline{BG} . Because the MCF5206e is performing a burst-inhibited access, it continues to assert \overline{BD} until the final transfer of the access has completed. The MCF5206e negates \overline{BD} during C8, returning ownership of the external bus to the external master.

In the second case, the bus lock bit in the SIM Configuration Register (SIMR) is set to 1 and the MCF5206e has explicit ownership of the bus. In this case, when the external bus master negates \overline{BG} , the MCF5206e continues to assert \overline{BD} and continues to drive address, attributes, and control signals. The MCF5206e retains mastership of the bus until the bus lock bit in the SIM Configuration Register (SIMR) is cleared. By setting the bus lock bit to 1, you can select the MCF5206e to be the highest priority master, even when

mastership of the bus is controlled by an external master. In this fashion, the MCF5206e can be guaranteed mastership of the bus when executing time critical, bus intensive operations. Figure 6-36 illustrates bus arbitration using the bus lock bit to control the arbitration.

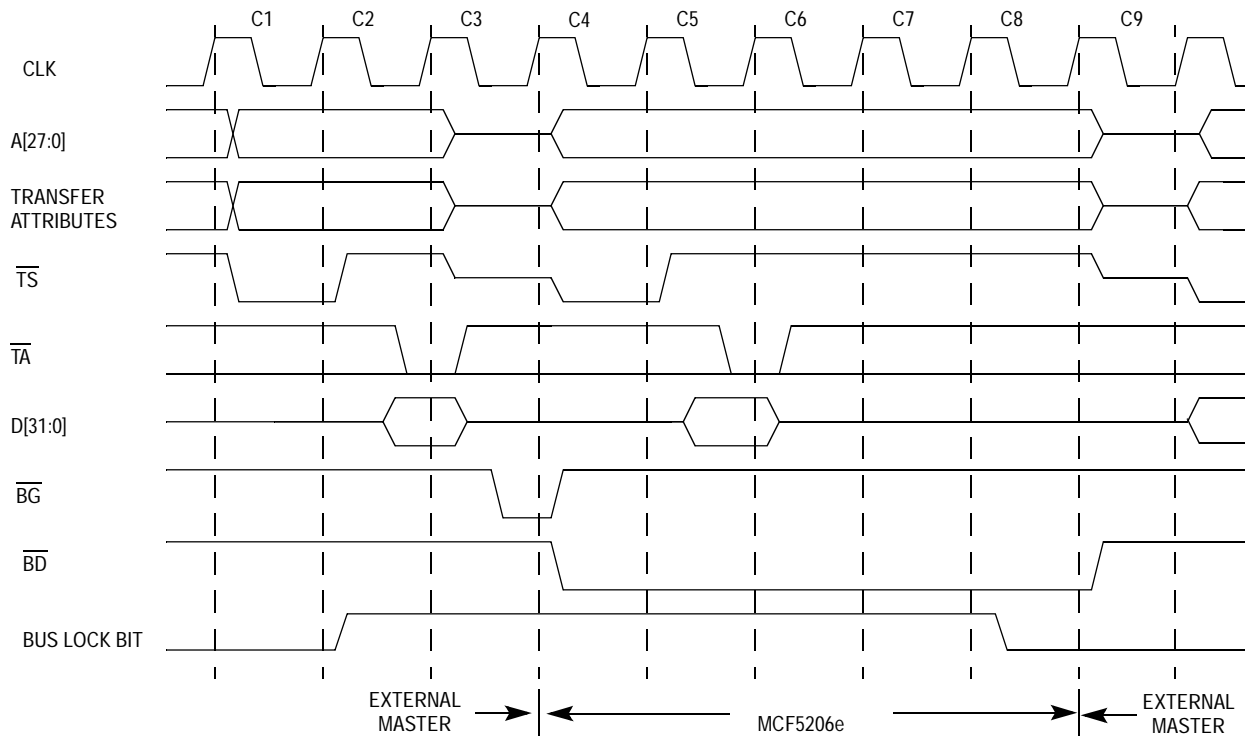

Figure 6-36. Two-Wire Bus Arbitration with Bus Lock Bit Asserted

In Figure 6-36 above, the external master is owner of the external bus during C1 and C2. During C3 the external master relinquishes control of the bus by asserting bus grant (\overline{BG}) to the MCF5206e. At this point the bus lock bit is set to 1, and there is an internal access pending so the MCF5206e asserts bus driven (\overline{BD}) during C4 and begins the access. Thus, the MCF5206e becomes the explicit master of the external bus. Also during C4, the external master removes the grant from the MCF5206e by negating bus grant (\overline{BG}). Because the MCF5206e is the current bus master and the bus lock bit in the SIM Configuration Register (SIMR) is set to 1, it continues to assert \overline{BD} even after the current transfer has completed. The MCF5206e negates the bus lock bit in SIMR during C8. Because bus grant (\overline{BG}) is negated, the MCF5206e negates bus driven (\overline{BD}) during C9 and three-states the external bus, thereby passing ownership of the external bus back to the external master.

Figure 6-37 is a bus arbitration state diagram for the MCF5206e bus arbitration protocol. Table 6-10 lists the conditions that cause bus arbitration state changes. Table 6-11 describes the MCF5206e bus ownership, bus driving and assertion of bus driven (BD) for

each state of the bus arbitration state machine.

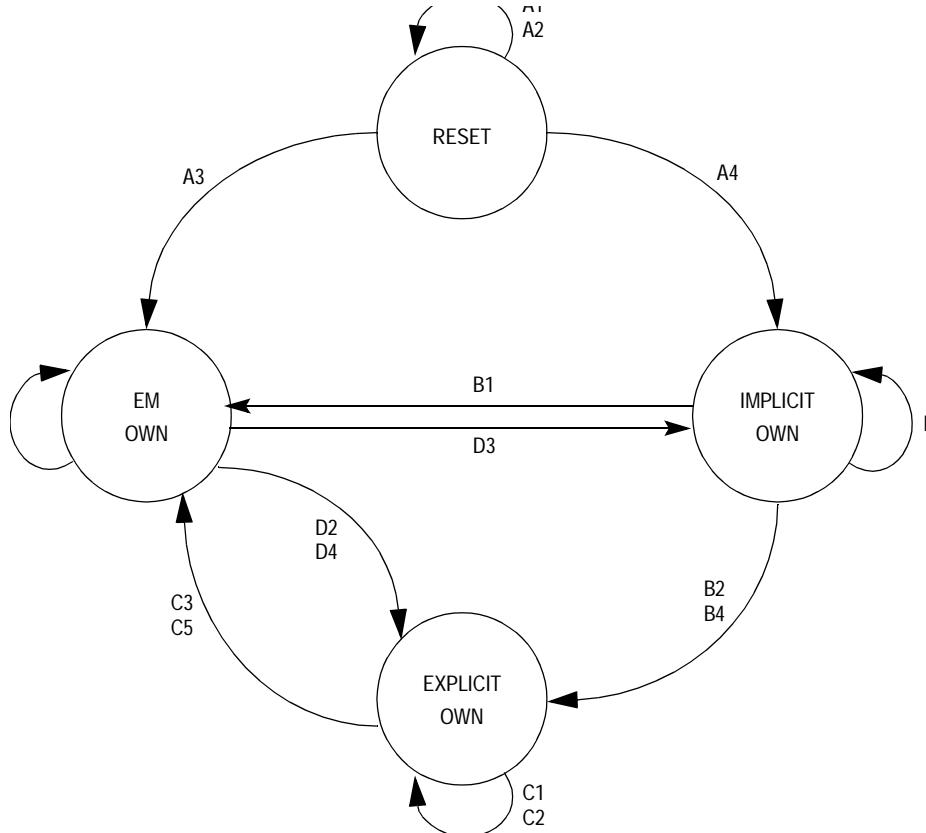

Figure 6-37. MCF5206e Two-Wire Bus Arbitration Protocol State Diagram

Table 6-10. MCF5206e Two-Wire Bus Arbitration Protocol Transition Conditions

PRESENT STATE	CONDITION LABEL	RSTI	SOFTWARE WATCHDOG RESET	BG	BUSLOCK BIT	INTERNAL BUS REQUEST	TRANSFER IN PROGRESS	END OF CYCLE	NEXT STATE
RESET	A1	A	-	-	-	-	-	-	Reset
	A2	N	A	-	-	-	-	-	Reset
	A3	N	N	N	-	-	-	-	EM Own
	A4	N	N	A	-	-	-	-	Implicit Own
IMPLICIT OWN	B1	N	N	N	-	-	-	-	EM Own
	B2	N	N	A	A	-	-	-	Explicit Own
	B3	N	N	A	N	N	-	-	Implicit Own
	B4	N	N	A	N	A	-	-	Explicit Own
EXPLICIT OWN	C1	N	N	A	-	-	-	-	Explicit Own
	C2	N	N	N	A	-	-	-	Explicit Own
	C3	N	N	N	N	-	N	-	EM Own
	C4	N	N	N	-	-	A	N	Explicit Own
	C5	N	N	N	N	-	A	A	EM Own
AM OWN	D1	N	N	N	-	-	-	-	EM Own
	D2	N	N	A	A	-	-	-	Explicit Own
	D3	N	N	A	N	N	-	-	Implicit Own
	D4	N	N	A	N	A	-	-	Explicit Own

NOTES

- 1) "N" means negated; "A" means asserted; "EM" means external master.
- 2) End of Cycle: Whatever terminates a bus transaction whether it is normal or bus error. Note that bus cycles that result from a burst inhibited transfer are considered part of that original transfer.

Table 6-11. MCF5206e Two-Wire Arbitration Protocol State Diagram

STATE	OWN	BUS STATUS	BD
Reset	No	Not Driven	Negated
Implicit Own	Yes	Not Driven	Negated
Explicit Own	Yes	Driven	Asserted
EM Own	No	Not Driven	Negated

The MCF5206e can be in any one of four arbitration states during bus operation: reset, external master ownership, implicit ownership, and explicit ownership.

The MCF5206e enters the reset state whenever \overline{RSTI} or software watchdog reset is asserted in any bus arbitration state. When \overline{RSTI} and the software watchdog reset are negated, the MCF5206e proceeds to the implicit ownership state or external master ownership state, depending on \overline{BG} .

The external master ownership state denotes the MCF5206e does not have ownership (\overline{BG} negated) of the bus and the MCF5206e does not drive the bus. The MCF5206e can assert memory control signals (i.e., $\overline{CS}[7:0]$, $\overline{WE}[3:0]$, $\overline{RAS}[1:0]$ or $\overline{CAS}[3:0]$) and transfer acknowledge (TA) during this state.

The implicit ownership state indicates that the MCF5206e owns the bus because \overline{BG} is asserted to it. The MCF5206e, however, is not ready to begin a bus cycle and the bus lock bit in the SIM Configuration Register (SIMR) is cleared. In this case, the MCF5206e keeps the bus three-stated until an internal bus request occurs or the bus lock bit in the SIMR is set to 1.

The MCF5206e explicitly owns the bus when the bus is granted to it (\overline{BG} asserted) and at least one bus cycle has been initiated or the bus lock bit in the SIMR is set to 1. The MCF5206e asserts \overline{BD} in this state to indicate the MCF5206e has explicit ownership of the bus. Until \overline{BG} is negated, the MCF5206e retains explicit ownership of the bus whether or not active bus cycles are being executed. Once \overline{BG} is negated and the bus lock bit in the SIMR is cleared, the MCF5206e relinquishes the bus at the end of the current bus cycle. When the MCF5206e is ready to relinquish the bus, it negates \overline{BD} and three-states the bus signals.

6.9.2 Multiple External Bus Master Arbitration Protocol (Three-Wire Mode)

The three-wire mode of bus arbitration allows the MCF5206e to share the external bus with any number of external bus masters. In this mode, an external arbiter must be provided to assign priorities to each of the possible bus masters and determine which master should be allowed use of the external bus. The bus arbitration signals of the

MCF5206e, \overline{BR} , \overline{BD} , and \overline{BG} connect to the bus arbiter, allowing the bus arbiter to control use of the external bus by the MCF5206e.

The MCF5206e requests the bus from the external bus arbiter by asserting bus request (\overline{BR}) whenever an internal bus request is pending (the ColdFire core requests an access). The MCF5206e continues to assert \overline{BR} until after the start of the external bus transfer. The MCF5206e can negate \overline{BR} at any time regardless of the bus grant (\overline{BG}) status. If the bus is granted to the MCF5206e when an internal bus request is generated, the MCF5206e asserts bus driven (\overline{BD}) simultaneously with transfer start, allowing the access to begin immediately. The MCF5206e always drives \overline{BR} and \overline{BD} . They cannot be directly wire-ORed with other devices.

The external arbiter asserts \overline{BG} to indicate to the MCF5206e that it has been granted the bus and may begin a bus cycle after the rising edge of the next CLK. If \overline{BG} is negated while a bus cycle is in progress, the MCF5206e relinquishes the bus at the completion of the bus cycle, except if the bus lock (BL) bit in the SIMR is set. To guarantee that the bus is relinquished, BL must be cleared and \overline{BG} must be negated prior to the rising edge of the CLK in which the last \overline{TA} , \overline{TEA} or internal asynchronous transfer acknowledge is asserted. Note that the MCF5206e considers any series of bus transfers of a burst or a burst-inhibited transfer to be a single bus cycle and does not relinquish the bus until completion of the last transfer of the series.

When the bus has been granted to the MCF5206e in response to the assertion of \overline{BR} , one of two situations can occur. In the first case, the MCF5206e has an internal bus request pending, the MCF5206e asserts \overline{BD} to indicate explicit bus ownership and begins the pending bus cycle by asserting \overline{TS} . The MCF5206e continues to assert \overline{BD} until the external bus master negates \overline{BG} , after which \overline{BD} is negated at the completion of the bus cycle. As long as \overline{BG} is asserted, \overline{BD} remains asserted to indicate the bus is owned by the MCF5206e and the MCF5206e continuously drives the address bus, attributes and control signals.

In the second situation, the bus is granted to the MCF5206e, but the MCF5206e does not have an internal bus request pending and the bus lock bit in the SIMR is cleared. In this case, the MCF5206e takes implicit ownership of the bus. Implicit ownership of the bus occurs when the MCF5206e is granted the bus, but there are no pending bus cycles. The MCF5206e does not drive the bus and does not assert \overline{BD} if the bus is implicitly owned. If an internal bus request is generated or the bus lock bit in the SIMR is set to 1, the MCF5206e assumes explicit ownership of the bus. If explicit ownership was assumed due to an internal request being generated, the MCF5206e immediately begins an access and simultaneously asserts \overline{BD} and \overline{TS} . If explicit ownership was assumed due to the bus lock bit being set to 1, the MCF5206e asserts \overline{BD} and drives the address, attributes, and control signals. In this case, the MCF5206e is the explicit master of the external bus, but does not begin an access until an internal request is generated. Figure 6-38 illustrates

implicit and explicit bus ownership due to the bus lock bit being set then an internal bus request being generated.

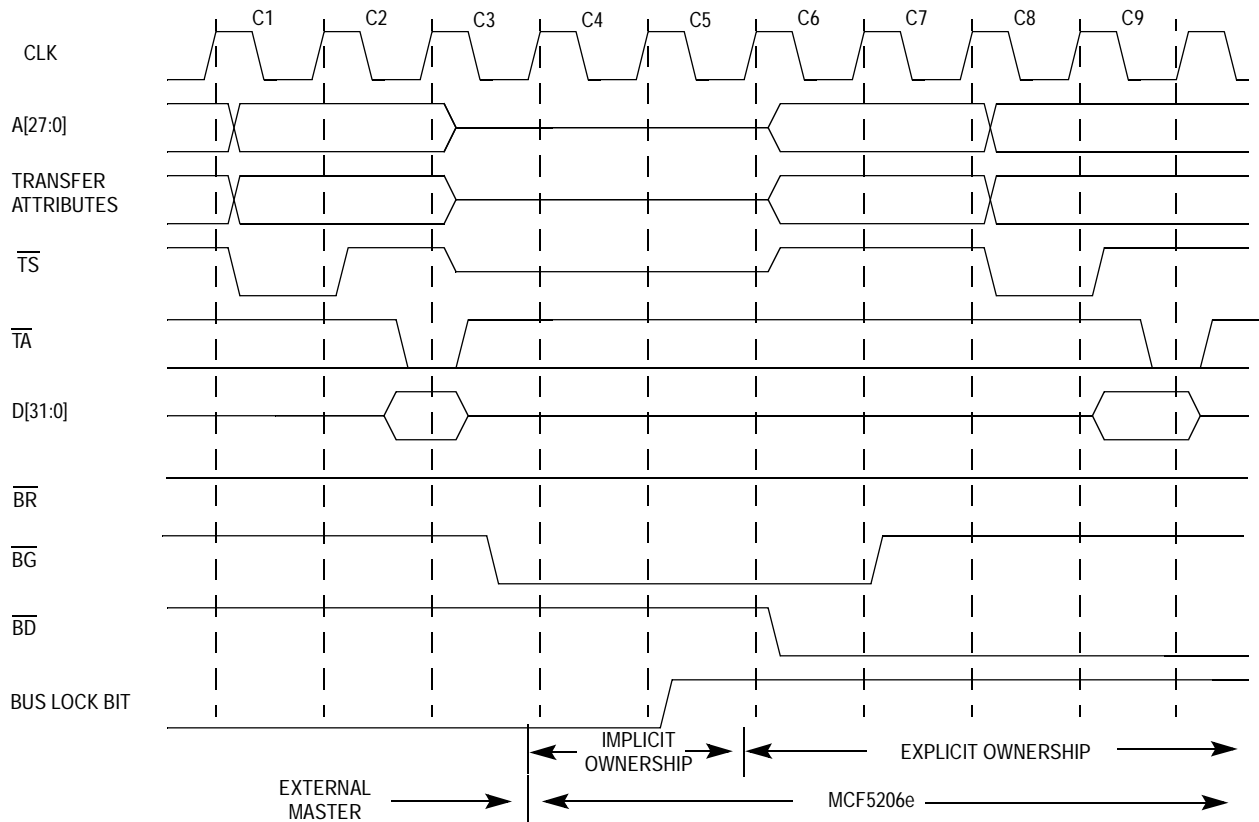

Figure 6-38. Three-Wire Implicit and Explicit Bus Ownership

In Figure 6-38, the external master has ownership of the external bus during C1 and C2. In C3, the external master releases control of the bus and the external arbiter asserts bus grant (\overline{BG}) to the MCF5206e. During C4 and C5, the MCF5206e is implicit owner because an internal access is not pending and the bus lock bit in the SIMR is cleared. During C5, the bus lock bit is set to 1, causing the MCF5206e to take explicit ownership of the bus during C6 by asserting \overline{BD} . During C7, the external arbiter removes the bus grant from the MCF5206e by negating \overline{BG} . Because the bus lock bit is set to 1, the MCF5206e does not relinquish the bus (the MCF5206e continues to assert \overline{BD})

NOTE

The MCF5206e can start a transfer during the CLK cycle after \overline{BG} is asserted. The external arbiter should not assert \overline{BG} to the MCF5206e until the previous external master has stopped driving the bus. \overline{BG} cannot be asserted while another external master transfer is still in progress or damage to the part could occur.

When the bus has been removed from the MCF5206e, one of two situations can occur. In the first case, the bus lock bit in the SIMR is cleared and the MCF5206e has explicit ownership of the bus. When the external bus master negates \overline{BG} , the MCF5206e completes the current transfer, then negates \overline{BD} and three-states the address, data, \overline{TS} , R/\overline{W} , and SIZ signals after completing the current bus cycle.

In the second case, the bus lock bit in the SIMR is set to 1 and the MCF5206e has explicit ownership of the bus. In this case, when the external bus master negates \overline{BG} , the MCF5206e continues to assert \overline{BD} and continues to drive address, attributes, and control signals. The MCF5206e retains mastership of the bus until the bus lock bit in the SIMR is cleared. By asserting the bus lock bit, you can select the MCF5206e to be the highest priority master, even when mastership of the bus is controlled by an external arbiter. In this fashion, the MCF5206e can be guaranteed mastership of the bus when executing time-critical, bus-intensive operations. Figure 6-39 illustrates bus arbitration using the bus lock bit to control the arbitration.

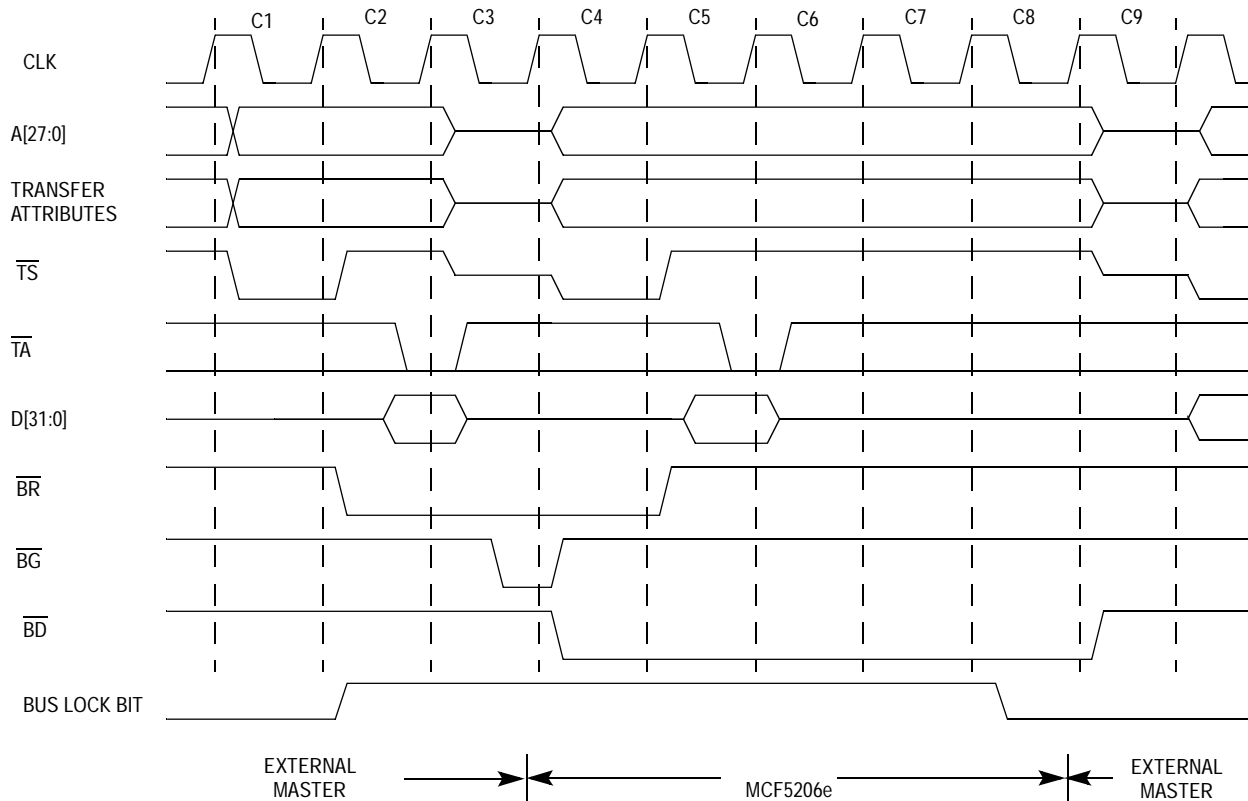

Figure 6-39. Three-Wire Bus Arbitration with Bus Lock Bit Asserted

In Figure 6-39, the external master is owner of the external bus during C1 and C2. During C2, the MCF5206e requests the external bus due to a pending internal transfer. On Clock C3, the external master relinquishes control of the bus and the external arbiter grants the bus to the MCF5206e by asserting bus grant (\overline{BG}). At this point the bus lock bit is set to 1, and there is an internal access pending so the MCF5206e asserts bus driven (\overline{BD}) during Clock C4, and begins the access. Thus, the MCF5206e becomes the explicit

master of the external bus. Also during C4, the external arbiter removes the grant from the MCF5206e by negating bus grant (\overline{BG}). Because the MCF5206e is the current bus master and the bus lock bit in the SIMR is set to 1, it continues to assert \overline{BD} even after the current transfer has completed. The MCF5206e negates the bus lock bit in the SIMR during C8. Because bus grant (\overline{BG}) is negated, the MCF5206e negates bus driven (\overline{BD}) during C9 and three-states the external bus, thereby passing ownership of the external bus to an external master.

\overline{BR} can be used by the external arbiter as an indication that the MCF5206e needs the bus. However, there is no guarantee that when the bus is granted to the MCF5206e, a bus cycle is performed. At best, \overline{BR} must be used as a status output that indicates when the MCF5206e needs the bus, but not as an indication that the MCF5206e is in a certain bus arbitration state.

Figure 6-40, a high level bus arbitration state diagram for the MCF5206e bus arbitration protocol, can be used by external arbiters to predict how the MCF5206e operates as a function of external signals. Table 6-11 lists conditions that cause a change to and from the various states. Table 6-12 describes the MCF5206e bus ownership, bus driving, and assertion of bus driven (\overline{BD}) for each state of the bus arbitration state machine.

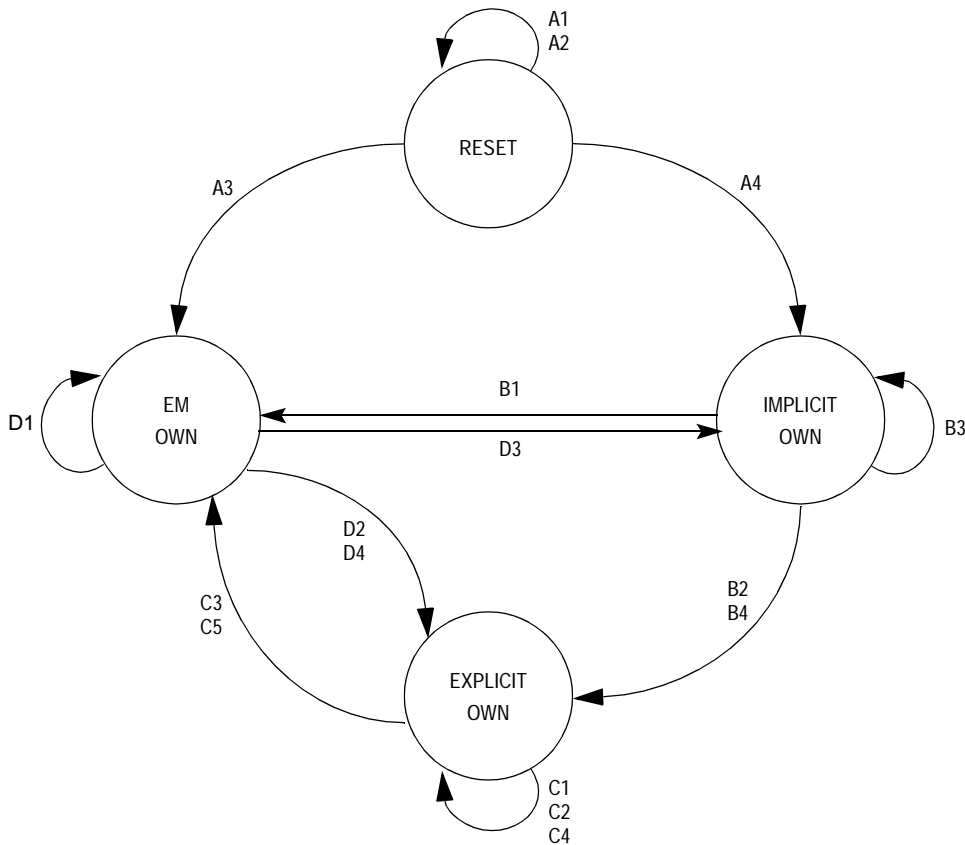

Figure 6-40. MCF5206e Bus Arbitration Protocol State Diagram

Table 6-12. MCF5206e Three-Wire Bus Arbitration Protocol Transition Conditions

PRESENT STATE	CONDITION LABEL	RSTI	SOFTWARE WATCHDOG RESET	BG	BUS LOCK BIT	INTERNAL BUS REQUEST (IBR)	TRANSFER IN PROGRESS	END OF CYCLE	NEXT STATE
RESET	A1	A	-	-	-	-	-	-	Reset
	A2	N	A	-	-	-	-	-	Reset
	A3	N	N	N	-	-	-	-	EM Own
	A4	N	N	A	-	-	-	-	Implicit Own
IMPLICIT OWN	B1	N	N	N	-	-	-	-	EM Own
	B2	N	N	A	A	-	-	-	Explicit Own
	B3	N	N	A	N	N	-	-	Implicit Own
	B4	N	N	A	-	A	-	-	Explicit Own
EXPLICIT OWN	C1	N	N	A	-	-	-	-	Explicit Own
	C2	N	N	N	Y	-	-	-	Explicit Own
	C3	N	N	N	N	-	N	-	EM Own
	C4	N	N	N	-	-	Y	N	Explicit Own
	C5	N	N	N	N	-	Y	Y	EM Own
EM OWN	D1	N	N	N	-	-	-	-	EM Own
	D2	N	N	A	A	-	-	-	Explicit Own
	D3	N	N	A	N	N	-	-	Implicit Own
	D4	N	N	A	N	A	-	-	Explicit Own

NOTES:

- 1) "N" means negated; "A" means asserted; "EM" means external master.
- 2) End of Cycle: Whatever terminates a bus transaction whether it is normal or bus error. Note that bus cycles that result from a burst inhibited transfer are considered part of that original transfer.
- 3) \overline{IBR} refers to an internal bus request. The output signals \overline{BR} is a registered version of \overline{IBR} when \overline{BG} is negated and \overline{BD} is negated. There is an internal bus request when the Coldfire core requires the external bus for an operand transfer.

Table 6-13. MCF5206e Three-Wire Arbitration Protocol State Diagram

STATE	OWN	BUS STATUS	BD
Reset	No	Not Driven	Negated
Implicit Own	Yes	Not Driven	Negated
Explicit Own	Yes	Driven	Asserted
EM Own	No	Not Driven	Negated

The MCF5206e can be in any one of four arbitration states during bus operation: reset, external master own, implicit ownership, and explicit ownership.

The reset state is entered whenever \overline{RSTI} or software watchdog reset is asserted in any bus arbitration state. When \overline{RSTI} and the software watchdog reset are negated, the MCF5206e proceeds to the implicit ownership state or external master ownership state, depending on bus grant (\overline{BG}).

The external master ownership state denotes the MCF5206e does not have ownership (bus grant (\overline{BG}) negated) of the bus and the MCF5206e does not drive the bus. The

MCF5206e can assert memory control signals (i.e., $\overline{CS}[7:0]$, $\overline{WE}[3:0]$, $\overline{RAS}[1:0]$ or $\overline{CAS}[3:0]$) \overline{TA} and \overline{BR} during this state.

The implicit ownership state indicates that the MCF5206e owns the bus because bus grant (\overline{BG}) is asserted to it. The MCF5206e, however, is not ready to begin a bus cycle and the bus lock bit in the SIMR is cleared, and it keeps the bus three-stated until an internal bus request occurs or the bus lock bit in the SIMR is set to 1.

The MCF5206e explicitly owns the bus when the bus is granted to it (bus grant (\overline{BG}) asserted) and at least one bus cycle has initiated or the bus lock bit in the SIMR is set to 1. The MCF5206e asserts \overline{BD} in this state to indicate the MCF5206e has explicit ownership of the bus. Until bus grant (\overline{BG}) is negated, the MCF5206e regains explicit ownership of the bus whether or not active bus cycles are being executed. Once bus grant (\overline{BG}) is negated and the bus lock bit in the SIMR is cleared, the MCF5206e relinquishes the bus at the end of the current bus cycle. When the MCF5206e is ready to relinquish the bus, it negates \overline{BD} and three-states the bus signals.

The bus arbitration state diagram for the MCF5206e three-wire bus arbitration protocol can be used to approximate the high level behavior of the MCF5206e. It is assumed that all \overline{TS} signals in a system are tied together and each bus master's \overline{BD} and \overline{BR} signals are connected individually to the external bus arbiter. The external bus arbiter must be careful to make sure any external bus master has relinquished the bus or will relinquish the bus after the next rising edge of CLK before asserting bus grant (\overline{BG}) to the MCF5206e. The MCF5206e does not monitor external bus master operation regarding bus arbitration.

NOTE

The MCF5206e can start a transfer on the rising edge of CLK the cycle after \overline{BG} is asserted. The external arbiter should not assert \overline{BG} to the MCF5206e until the previous external master has stopped driving the bus. \overline{BG} cannot be asserted while another external master transfer is still in progress or damage to the part could occur.

6.10 EXTERNAL BUS MASTER OPERATION

The MCF5206e can monitor bus transfers by other bus masters and can assert chip selects, DRAM control, and transfer termination signals during these transfers. Assertion of chip selects and DRAM control signals can occur when the bus is granted to another bus master and \overline{TS} is asserted by the external master as an input to the MCF5206e.

NOTE

External masters that are using internal MCF5206e chip selects, DRAM, and default memory control signals must initiate aligned transfers only.

The MCF5206e registers the value of A[27:0], $\overline{R/\overline{W}}$, and SIZ[1:0] on the rising edge of CLK in which \overline{TS} is asserted.

NOTE

If the pins A[27:24]/ \overline{CS} [7:4]/ \overline{WE} [0:3] are not assigned to output address signals, a value of \$0 is assigned internally to A[27:24]. Also, TT[1:0] and ATM are not examined during external master transfers. The mask bits SC, SD, UC, UD and C/I in the Chip Select Mask Registers (CSMR) and in the DRAM Controller Mask Registers (DCMR) are not used during external master transfers.

If the assertion of chip selects, DRAM control, and transfer termination signals during external master accesses is not required, the MCF5206e \overline{TS} pin should not be asserted when bus driven (\overline{BD}) is negated.

This subsection concentrates on external master accesses to default memory. For more information on external master accesses to chip select and DRAM memory spaces, refer to **Section 8 Chip Select** and **Section 10 DRAM Controller**.

During external master transfers, the MCF5206e examines the address, direction, and size of the transfer, and on the next rising edge of CLK, begins assertion of the proper sequence of memory control signals. If the transfer is decoded to be a chip select address and the chip select is enabled for the direction of the transfer (read- and/or write enabled), the appropriate chip selects and write enable signals are asserted. If the chip select is enabled for external master automatic acknowledge, \overline{TA} is driven and asserted at the appropriate time.

The MCF5206e does not drive addresses during external bus master accesses that are decoded as chip select or default memory transfers. The external master must provide the correct address to the external memory at the appropriate time. If the transfer is decoded to be a DRAM address and the DRAM bank is enabled for the direction of the transfer (read- and/or write enabled), the appropriate DRAM control address and the transfer-acknowledge (\overline{TA}) signals are asserted. If the address of the transfer is neither a chip-select or a DRAM address, the SIM reads the DMCR. If the external master automatic acknowledge (EMAA) bit in the DMCR is set, the MCF5206e drives \overline{TA} and asserts transfer acknowledge after the number of clocks programmed in the wait state bits (WS) in the DMCR. For more information about programming the Default Memory Control Register, refer to the SIM section. Table 6-13 lists the signals and conditions under which the MCF5206e drives these signals during external master accesses.

Table 6-14. Signal Source During External Master Accesses

MEMORY SPACE	ADDRESS (DRIVEN BY)	CONTROL SIGNALS	TRANSFER ACKNOWLEDGE
Chip Select	External Master	CS[7:0], WE[3:0]	MCF5206e: if EMAA in CSCR is set to 1
DRAM	MCF5206e: if DCAR in DCCR is set to 1	RAS[1:0], CAS[3:0], DRAMW	MCF5206e
Default Memory	External Master	-	MCF5206e: if EMAA in DMCR is set to 1

6.10.1 External Master Read Transfer Using MCF5206e Termination

The basic read cycle of an external master transfer using MCF5206e-generated termination is the same as a ColdFire core initiated transfer with one additional CLK cycle between the assertion of \overline{TS} by the external master and the starting of the internal wait-state counter by the MCF5206e. During this CLK cycle, the MCF5206e decodes the external master address to determine the appropriate memory control and termination signals that must be asserted. For more information on chip select transfers and DRAM transfers, refer to **Section 8 Chip Selects** and **Section 10 DRAM Controller**.

Figure 6-41 is a flow chart for external master read transfers using MCF5206e-generated automatic acknowledge to access 8-, 16-, or 32-bit ports. Bus operations are similar for each case and vary only with the size indicated, the portion of the data bus used for the

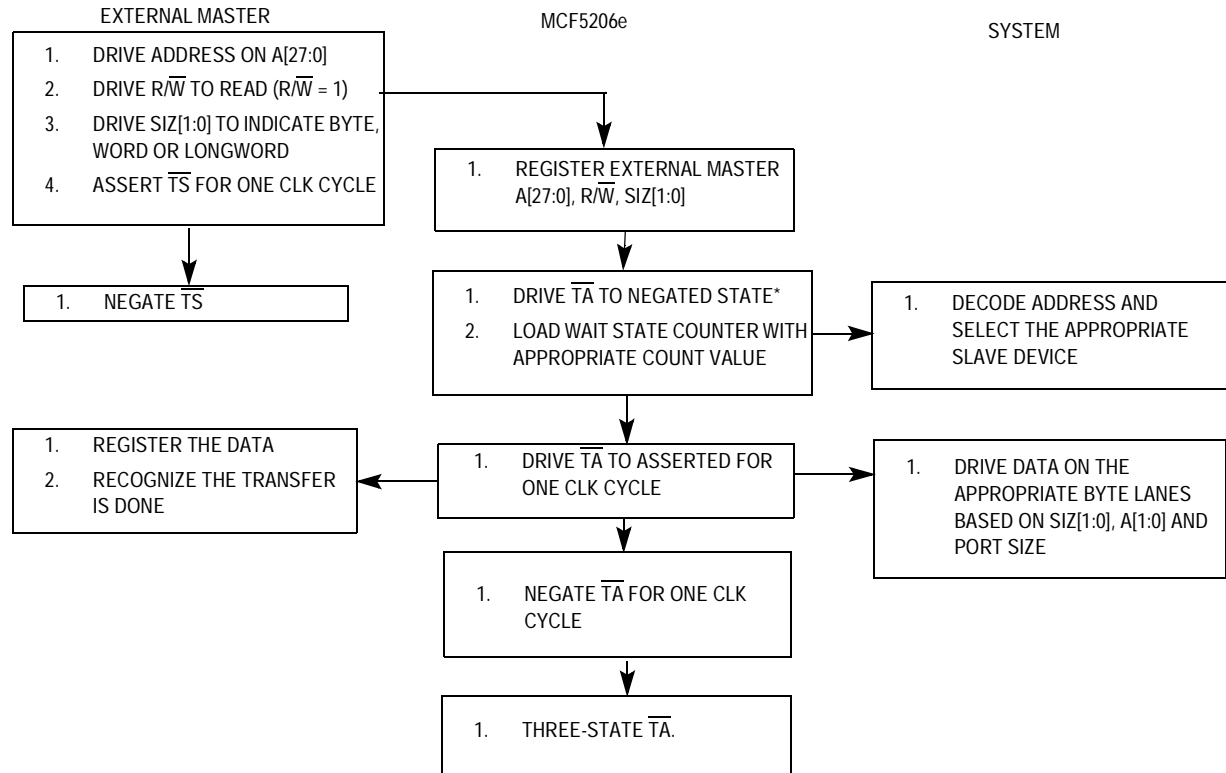

*TA IS DRIVEN NEGATED IF THE APPROPRIATE WAIT STATE COUNT IS GREATER THAN ZERO. IF THE WAIT STATE COUNT IS ZERO, TA IS DRIVEN AND ASSERTED DURING THE SAME CLK.

transfer, and the specific number of cycles needed for each transfer.

Figure 6-41. External Master Read Transfer using MCF5206e-Generated Transfer Acknowledge Flowchart

Figure 6-42 illustrates transfer acknowledge ($\overline{\text{TA}}$) assertion by the MCF5206e during external master read transfers.

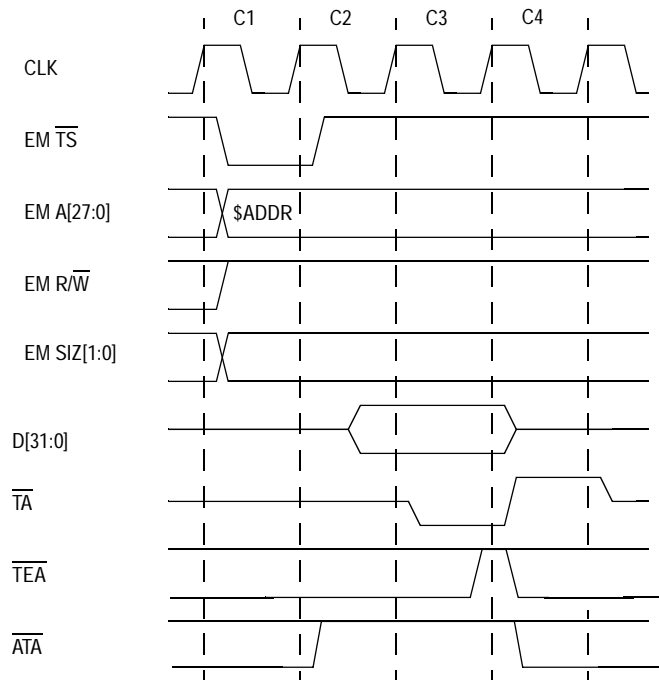

Figure 6-42. External Master Read Transfer Using MCF5206e Transfer Acknowledge Timing (No Wait States)

Clock 1 (C1)

The read cycle starts in C1. During C1, the external master drives valid values on the address bus (A[27:0]) and transfer control signals. The read/write (R/W) signal is driven high for a read cycle, and the size signals (SIZ[1:0]) are driven to indicate the transfer size. The external master asserts transfer start ($\overline{\text{TS}}$) to indicate the beginning of a bus cycle.

Clock 2 (C2)

At the start of C2, the MCF5206e registers the external master address bus, read/write and size signals. During C2, the MCF5206e decodes the registered address and read/write signals and if the external master automatic acknowledge (EMAA) bit in the Default Memory Control Register (DMCR) is set to 1, the MCF5206e selects the indicated number of wait states for loading into the internal wait state counter. During C2, the external master negates $\overline{\text{TS}}$ and samples the level of $\overline{\text{TA}}$. The selected device(s) decodes the address and drives the appropriate data onto the data bus.

Clock 3 (C3)

At the start of C3, if the EMAA bit in the Default Memory Control Register (DMCR) is set to 1 and the number of wait states is zero, the MCF5206e drives $\overline{\text{TA}}$ signal to the asserted

state. During C3, the external master samples the level of \overline{TA} and if \overline{TA} is asserted, latches the data and terminates the transfer. If \overline{TA} is negated, the external master continues to insert wait states instead of terminating the transfer. The external master must continue to sample \overline{TA} on successive rising edges of CLK until it is asserted.

Clock 4 (C4)

During C4, the selected slave device drives the data bus to a high-impedance state. The MCF5206e negates \overline{TA} and drives \overline{TA} to a high-impedance state after the next rising edge of CLK.

6.10.2 External Master Write Transfer Using MCF5206e Termination

The basic write cycle of an external master transfer using MCF5206e-generated termination is the same as a ColdFire core-initiated transfer with one additional CLK cycle between the assertion of \overline{TS} by the external master and the start of the internal wait state counter by the MCF5206e. During this CLK cycle, the MCF5206e decodes the external master address to determine the appropriate memory control and termination signals that must be asserted. For more information on chip select transfers, refer to the Chip Selects section. For more information on DRAM transfers, refer to the DRAM Controller section.

Figure 6-43 is a flow chart for external master write transfers using MCF5206e-generated automatic acknowledge to access 8-, 16-, or 32-bit ports. Bus operations are similar for each case and vary only with the size indicated, the portion of the data bus used for the transfer, and the specific number of cycles needed for each transfer.

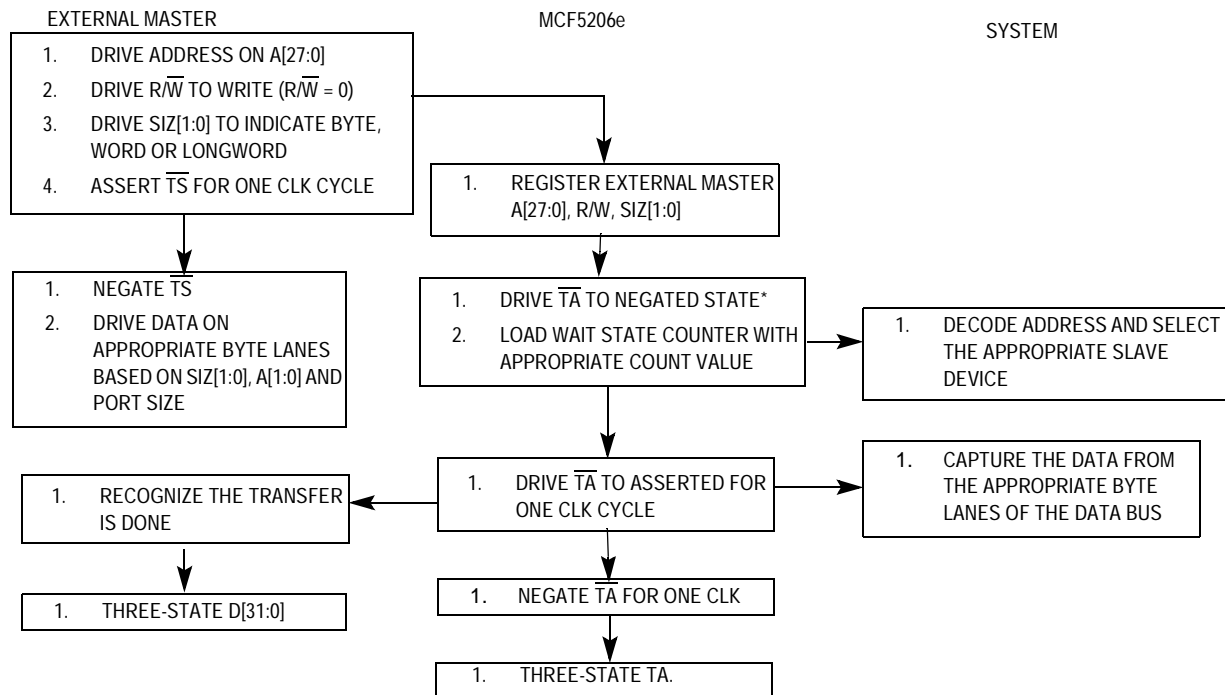

* \overline{TA} IS DRIVEN AND NEGATED IF THE APPROPRIATE WAIT STATE COUNT IS GREATER THAN ZERO. IF THE WAIT STATE COUNT IS ZERO, \overline{TA} IS DRIVEN AND ASSERTED DURING THE SAME CLK.

Figure 6-43. External Master Write Transfer Using MCF5206e-Generated Transfer Acknowledge Flowchart

Figure 6-44 illustrates \overline{TA} assertion by the MCF5206e during external master write transfers.

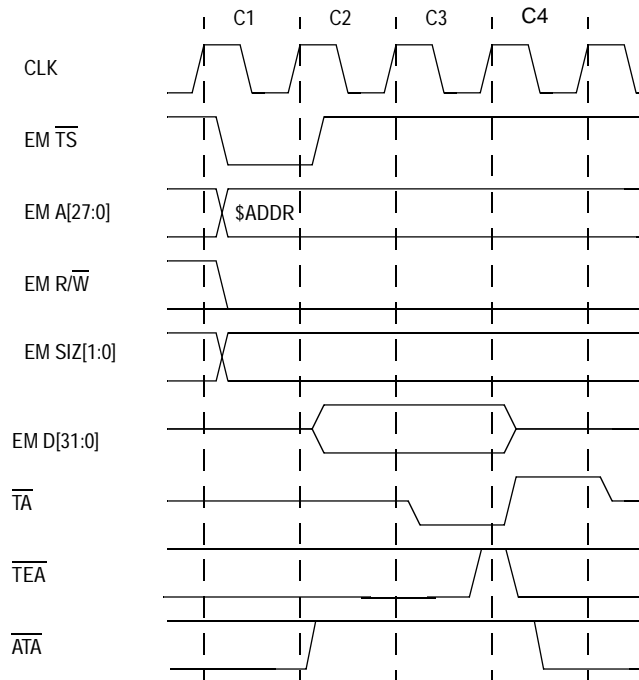

Figure 6-44. External Master Write Transfer Using MCF5206e Transfer-Acknowledge Timing (No Wait States)

Clock 1 (C1)

The write cycle starts in C1. During C1, the external master drives valid values on the address bus (A[27:0]) and transfer control signals. The read/write ($\overline{R/\overline{W}}$) signal is driven low for a write cycle, and the size signals (SIZ[1:0]) are driven to indicate the transfer size. The external master asserts transfer start (\overline{TS}) to indicate the beginning of a bus cycle.

Clock 2 (C2)

At the start of C2, the MCF5206e registers and decodes the external master address bus, read/write and size signals. If the external master automatic acknowledge (EMAA) bit in the Default Memory Control Register (DMCR) is set to 1, the MCF5206e selects the indicated number of wait states for loading into the internal wait state counter. During C2, the external master negates \overline{TS} , places the data on the data bus (D[31:0]), and samples the level of \overline{TA} . The selected device(s) decode the address and latch the data when it is ready.

Clock 3 (C3)

At the start of C3, if the EMMA bit in the Default Memory Control Register (DMCR) is set to 1 and the number of wait states is zero, the MCF5206e asserts \overline{TA} . During C3, the external master samples the level of \overline{TA} . If \overline{TA} is asserted, the external master terminates

the transfer. If \overline{TA} is negated, the external master continues to output the data and inserts wait states instead of terminating the transfer. The external master must continue to sample \overline{TA} on successive rising edges of CLK until it is asserted.

Clock 4 (C4)

During C4, the external master places the data bus in a high-impedance state. The MCF5206e negates \overline{TA} and drives \overline{TA} to a high impedance state after the next rising edge of CLK.

6.10.3 External Master Bursting Read Using MCF5206e-Generated Transfer Termination

The bursting read transfer of an external master transfer using MCF5206e-generated termination is similar to a ColdFire core initiated bursting transfer with the exception that one additional CLK cycle is inserted between the assertion of \overline{TS} by the external master and the starting of the internal wait state counter by the MCF5206e. If the transfer is to default memory, the external master must increment the address to the appropriate value after each assertion of transfer acknowledge. For more information on chip select transfers, refer to **Section 8 Chip Selects**. For more information on DRAM transfers, refer to **Section 10 DRAM Controller**.

NOTE

An external master cannot initiate a bursting read transfer for a chip select or default memory space where the burst-enable bit (BRST) in the Chip Select Control Register (CSCR) or the Default Memory Control Register (DMCR) is cleared. Undefined behavior occurs if you attempt such a transfer.

Figure 6-45 is a flowchart for an external master bursting read transfer using MCF5206e-generated automatic acknowledge to access 8-, 16-, or 32-bit ports. Bus operations are similar for each case and vary only with the size indicated, the portion of the data bus used for the transfer, and the specific number of cycles needed for each transfer. A bursting read transfer can be from two to sixteen transfers long. The flowchart in Figure 6-45 is for a bursting transfer four transfers long.

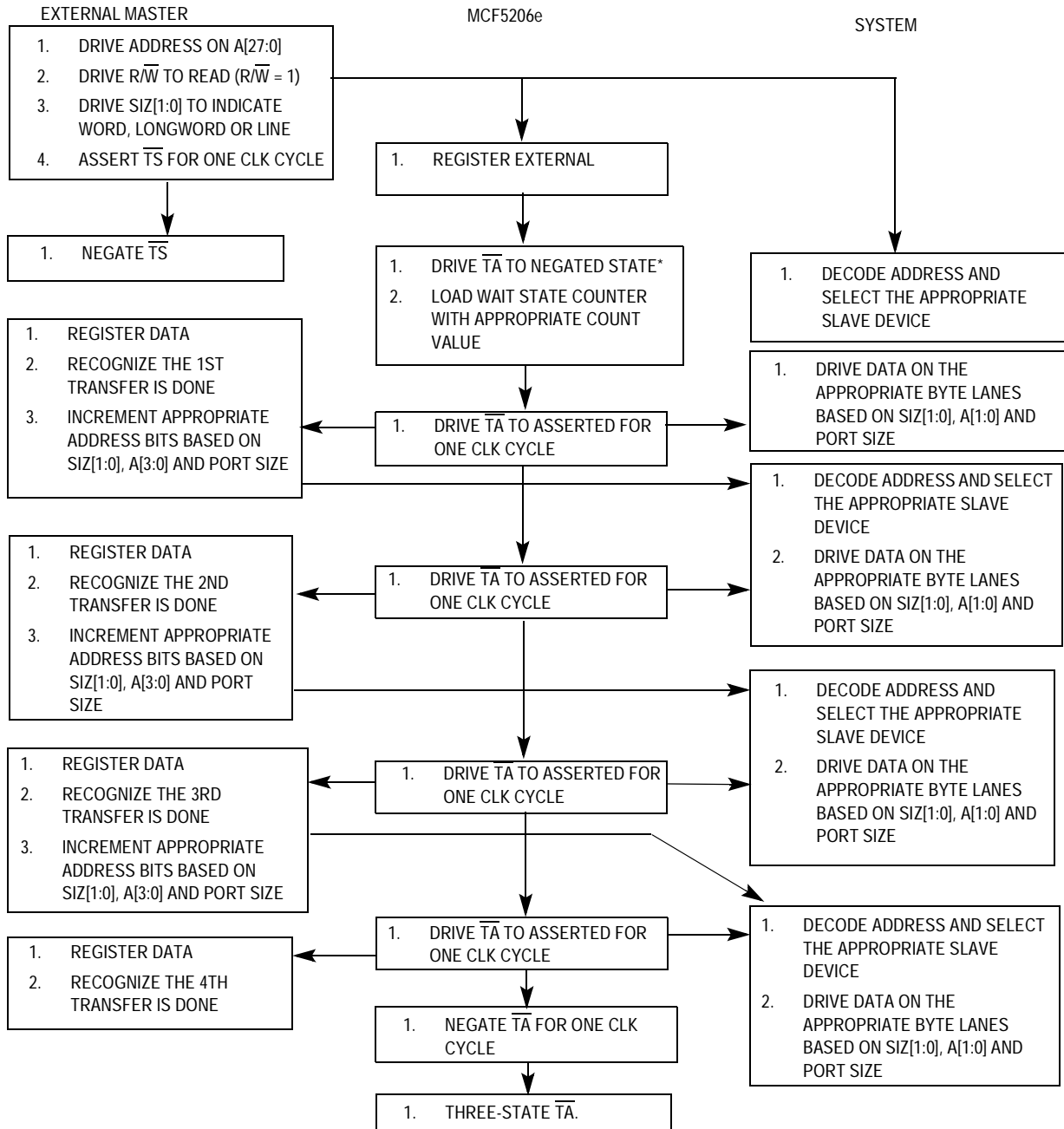

Figure 6-45. External Master Bursting Read Transfer Using MCF5206e-Generated Transfer-Acknowledge Flowchart

Figure 6-46 illustrates \overline{TA} assertion by the MCF5206e during external master bursting read transfers.

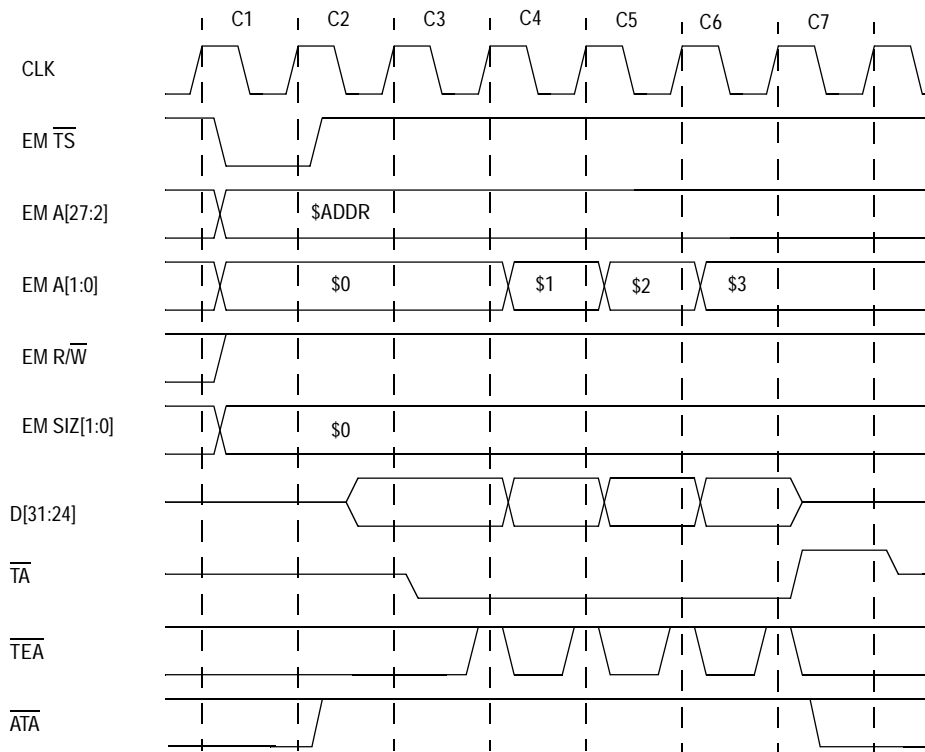

Figure 6-46. External Master Bursting Longword Read Transfer to an 8-Bit Port Using MCF5206e Transfer-Acknowledge Timing (No Wait States)

Clock 1 (C1)

The read cycle starts in C1. During C1, the external master places valid values on the address bus (A[27:0]) and transfer control signals. The read/write (R/W) signal is driven high for a read cycle, and the size signals (SIZ[1:0]) are driven to \$0 to indicate a longword transfer. The external master asserts \overline{TS} to indicate the beginning of a bus cycle.

Clock 2 (C2)

At the start of C2, the MCF5206e registers the external master address bus, read/write and size signals. During C2, the MCF5206e decodes the registered address and read/write signals and if the external master automatic acknowledge (EMAA) bit in the Default Memory Control Register (DMCR) is set to 1, the MCF5206e selects the indicated number of wait states for loading into the internal wait state counter. During C2, the external master negates \overline{TS} and samples the level of \overline{TA} . The selected device(s) decodes the address and drives the appropriate data onto the data bus.

Clock 3 (C3)

At the start of C3, if the EMAA bit in the Default Memory Control Register (DMCR) is set to 1 and the number of wait states is zero, the MCF5206e drives \overline{TA} signal to the asserted state. During C3, the external master samples the level of \overline{TA} . If \overline{TA} is asserted, the external master latches the first byte of data from D[31:24]. If \overline{TA} is negated, the external master continues to insert wait states instead of terminating the transfer. The external master must continue to sample \overline{TA} on successive rising edges of CLK until it is asserted.

Clock 4 (C4)

During C4, the external master increments the address by one to access the second byte of data in the longword transfer. The external master also samples the level of \overline{TA} . If \overline{TA} is asserted, the external master latches the second byte of data from D[31:24]. If \overline{TA} is negated, the external master continues to insert wait states instead of terminating the transfer. The external master must continue to sample \overline{TA} on successive rising edges of CLK until it is asserted.

The selected slave decodes the address and outputs the next byte of data on D[31:24]. The MCF5206e continues to assert \overline{TA} .

Clock 5 (C5)

This clock is identical to C4 except the external master increments the address to point to the third byte of data, and the selected slave decodes the address and outputs the third byte of data of the longword transfer.

Clock 6 (C6)

This clock is identical to C4 except the external master increments the address to point to the fourth byte of data, and the selected slave decodes the address and outputs the fourth byte of data of the longword transfer.

Clock 7 (C7)

During C7, the selected slave device drives the data bus to a high impedance state. The MCF5206e drives \overline{TA} to the inactive state and then drives \overline{TA} to a high-impedance state after the next rising edge of CLK.

6.10.4 External Master Bursting Write Using MCF5206e-Generated Transfer Termination

The bursting write transfer of an external master using MCF5206e-generated termination is similar to a ColdFire core initiated bursting write transfer except that one additional CLK cycle is inserted between the assertion of \overline{TS} by the external master and the start of the internal wait state counter by the MCF5206e. If the transfer is to default memory, the external master must increment the address to the appropriate value after each assertion

of transfer acknowledge. For more information on chip select transfers or DRAM transfers, refer to **Section 8 Chip Selects** or to **Section 10 DRAM Controller**.

NOTE

An external master cannot initiate a bursting write transfer for a chip select or default memory space where the burst-enable bit (BRST) in the Chip Select Control Register (CSCR) or the Default Memory Control Register (DMCR) is cleared. Undefined behavior occurs if you try this.

Figure 6-47 is a flowchart for external master bursting write transfer using MCF5206e generated automatic acknowledge to access 8-, 16- or 32-bit ports. Bus operations are similar for each case and vary only with the size indicated, the portion of the data bus used for the transfer and the specific number of cycles needed for each transfer. A bursting write transfer can be from two to sixteen transfers long. The flowchart shown in Figure 6-47 is for a bursting write transfer of four transfers long.

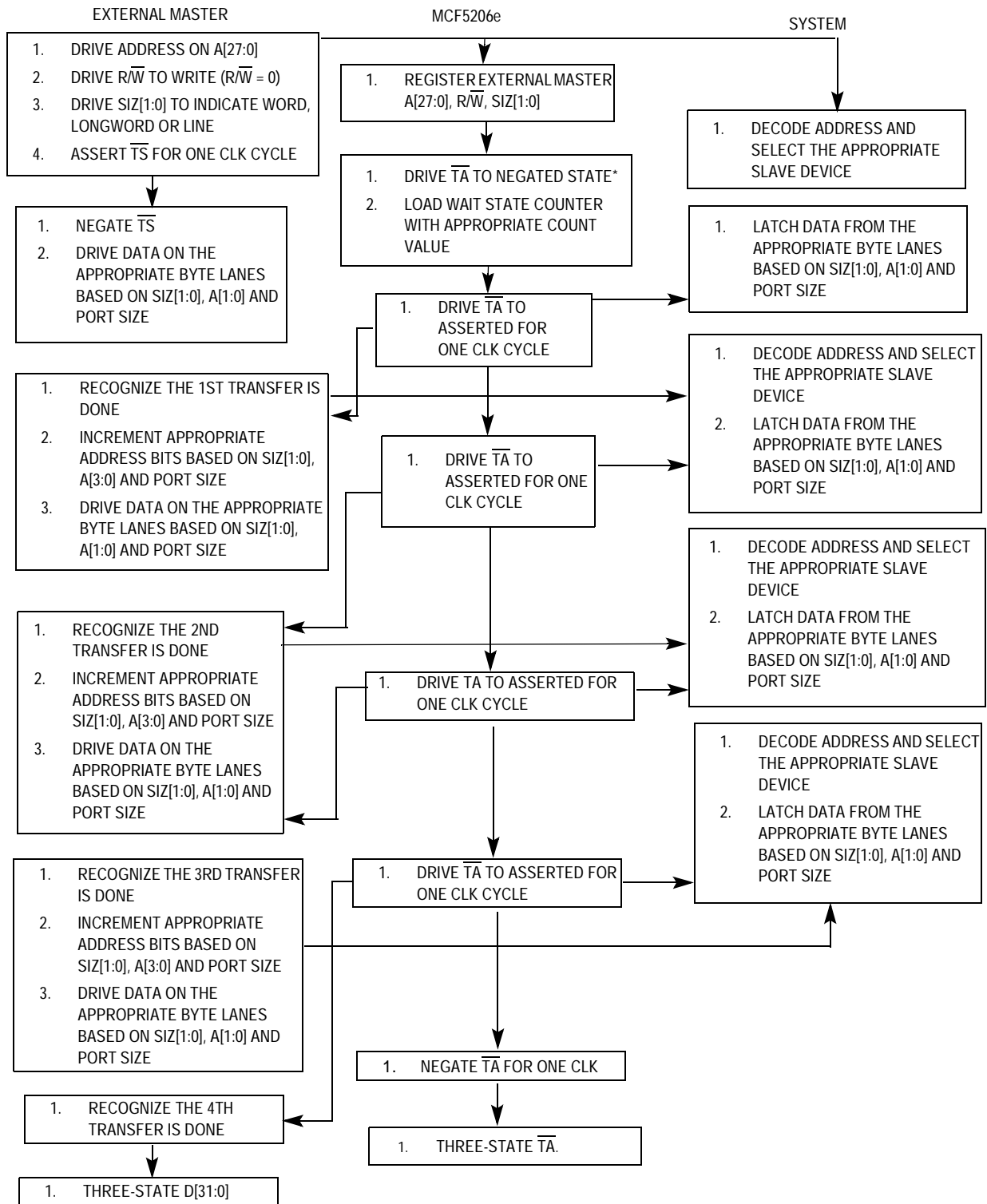

* \overline{TA} IS DRIVEN AND NEGATED IF THE APPROPRIATE WAIT STATE COUNT IS GREATER THAN ZERO. IF THE WAIT STATE COUNT IS ZERO, \overline{TA} IS DRIVEN AND ASSERTED DURING THE SAME CLK.

Figure 6-47. External Master Bursting Write Transfer using MCF5206e-Generated Transfer-Acknowledge Flowchart

Freescale Semiconductor, Inc.

Figure 6-48 illustrates \overline{TA} assertion by the MCF5206e during external master bursting write transfers.

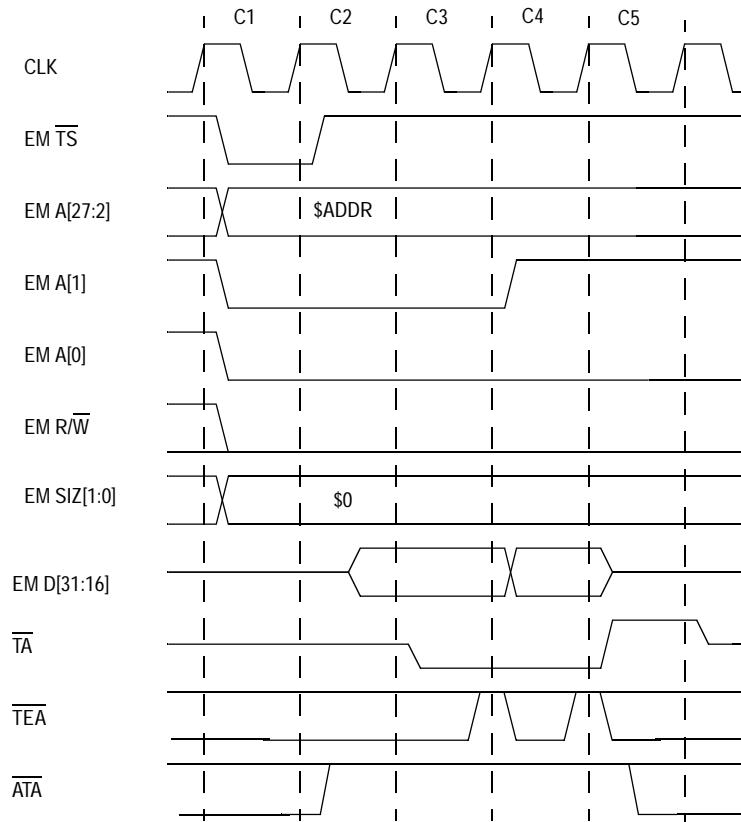

Figure 6-48. External Master Bursting Longword Write Transfer to a 16-Bit Port Using MCF5206e Transfer Acknowledge Timing (No Wait States)

Clock 1 (C1)

The write cycle starts in C1. During C1, the external master places valid values on the address bus (A[27:0]) and transfer control signals. The read/write ($\overline{R/W}$) signal is driven low for a write cycle, and the size signals (SIZ[1:0]) are driven to \$0 to indicate a longword transfer. The external master asserts \overline{TS} to indicate the beginning of a bus cycle.

Clock 2 (C2)

At the start of C2, the MCF5206e registers and decodes the external master address bus, read/write and size signals. If the external master automatic acknowledge (EMAA) bit in the Default Memory Control Register (DMCR) is set to 1, the MCF5206e selects the indicated number of wait states for loading into the internal wait state counter. During C2, the external master negates \overline{TS} , drives the appropriate data onto the data bus, and samples the level of \overline{TA} . The selected device(s) decodes the address and if ready, latches the appropriate data from the data bus.

Clock 3 (C3)

At the start of C3, if the EMAA bit in the Default Memory Control Register (DMCR) is set to 1 and the number of wait states is zero, the MCF5206e asserts \overline{TA} . During C3, the external master samples the level of \overline{TA} . If \overline{TA} is asserted, the transfer of the first word is complete. If \overline{TA} is negated, the external master continues to insert wait states instead of terminating the transfer. The external master must continue to sample \overline{TA} on successive rising edges of CLK until it is asserted.

Clock 4 (C4)

During C4, the external master increments the address by two to point to the second word of data in the longword transfer and outputs the second word of data onto the data bus. The external master also samples the level of \overline{TA} . If \overline{TA} is asserted, the transfer of the second word of the longword transfer is complete. If \overline{TA} is negated, the external master continues to insert wait states instead of terminating the transfer. The external master must continue to sample \overline{TA} on successive rising edges of CLK until it is asserted.

The selected slave decodes the address and latches the next word of data on D[31:16]. The MCF5206e continues to assert \overline{TA} .

Clock 5 (C5)

During C5, the external master drives the data bus to a high impedance state. The MCF5206e drives \overline{TA} to the inactive state and places \overline{TA} in a high-impedance state after the next rising edge of CLK.

6.11 RESET OPERATION

The MCF5206e supports three types of reset, two of which are external hardware resets (master reset and normal reset) and one internal reset—Software Watchdog reset. Master reset resets the entire MCF5206e including the DRAM controller. Normal reset resets all of the MCF5206e with the exception of the DRAM controller. Normal reset allows DRAM refresh cycles to continue at the programmed rate and with the programmed waveform timing while the remainder of the system is being reset, maintaining the data stored in DRAM. The Software Watchdog resets act as internally generated normal resets.

NOTE

Master reset must be asserted for all power-on resets. Failure to assert master reset during power-on sequences results in unpredictable DRAM controller behavior.

6.11.1 MASTER RESET

To perform a master reset, an external device asserts the reset input pin (\overline{RSTI}) and the HIZ input pin (\overline{HIZ}) simultaneously. When power is applied to the system, external circuitry should assert \overline{RSTI} for a minimum of six CLK cycles after V_{CC} is within tolerance. Figure

6-49 is a functional timing diagram of the master reset operation, illustrating relationships among V_{CC} , \overline{RSTI} , HIZ , \overline{RSTO} , mode selects, and bus signals. CLK must be stable by the time V_{CC} reaches the minimum operating specification. CLK should start oscillating as V_{CC} is ramped up to clear out contention internal to the MCF5206e caused by the random manner in which internal flip-flops power up. \overline{RSTI} and HIZ are internally synchronized on consecutive rising and falling clocks before being used and must meet the specified setup and hold times to the falling edge of the clock only if recognition by a specific CLK falling edge is required.

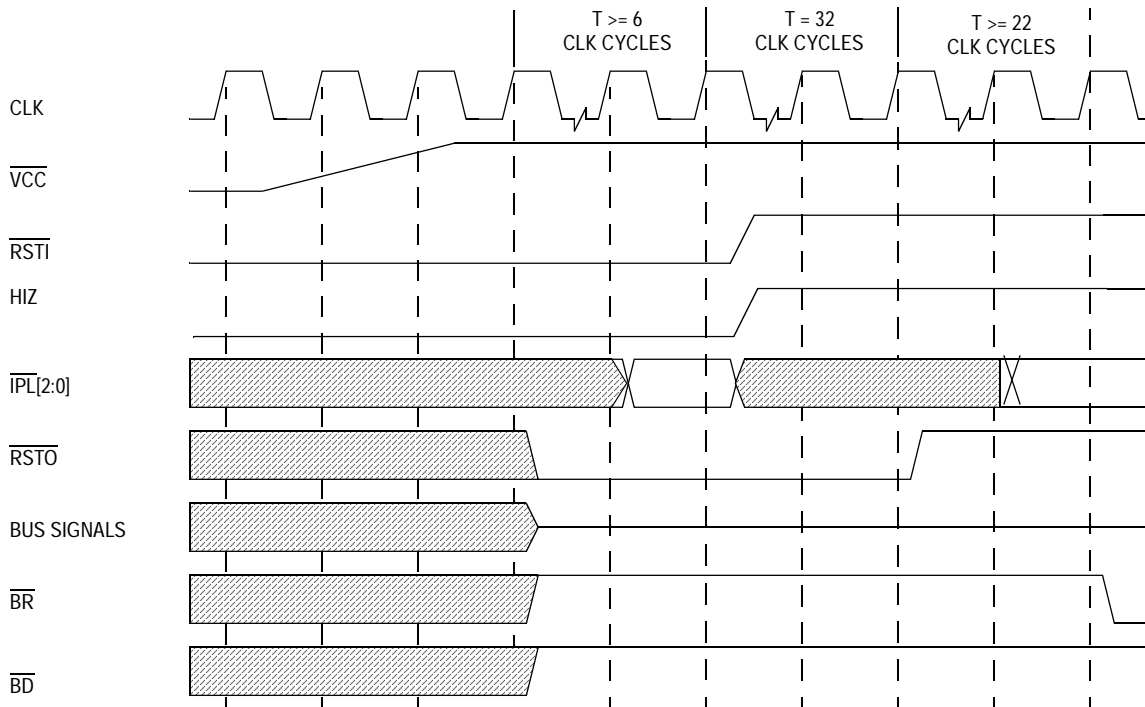

Figure 6-49. Master Reset Timing

\overline{TS} must be pulled up or negated during master reset. When the assertion of \overline{RSTI} is recognized internally, the MCF5206e asserts the reset out pin (\overline{RSTO}). \overline{RSTO} is asserted as long as \overline{RSTI} is asserted and remains asserted for 32 CLK cycles after \overline{RSTI} is negated. For proper master reset operation, \overline{RSTI} and HIZ must be asserted and negated simultaneously.

During the master reset period, all signals that can be driven to a high-impedance state and all those that cannot be driven to a high-impedance state are driven to their negated states. Once \overline{RSTI} negates, all bus signals continue to remain in a high-impedance state until the MCF5206e is granted the bus and the ColdFire core begins the first bus cycle for reset exception processing. A master reset causes any bus cycle (including DRAM refresh cycles) to terminate. In addition, master reset initializes registers appropriately for a reset exception. During a master reset, the hard reset bit (HRST) bit in the Reset Status Register (RSR) is set and the software reset bit (SRST) in the Reset Status Register (RSR) is cleared to indicate that an external hardware reset caused the previous reset.

The levels of the $\overline{\text{IPLx}}$ pins select the port size and acknowledge features of the global chip select after a master reset occurs. The $\overline{\text{IPLx}}$ signals are synchronized and are registered on the last falling edge of CLK where $\overline{\text{RSTI}}$ and $\overline{\text{HIZ}}$ are asserted.

6.11.2 NORMAL RESET

External normal resets should be performed anytime it is important to maintain the data stored in DRAM during a reset. An external normal reset is performed when an external device asserts the reset input pin ($\overline{\text{RSTI}}$) while negating the $\overline{\text{HIZ}}$ input pin ($\overline{\text{HIZ}}$). During an external normal reset, $\overline{\text{RSTI}}$ must be asserted for a minimum of six CLKs. Figure 6-50 is a functional timing diagram of external normal reset operation, illustrating relationships among $\overline{\text{RSTI}}$, $\overline{\text{HIZ}}$, $\overline{\text{RSTO}}$, mode selects, and bus signals. $\overline{\text{RSTI}}$ and $\overline{\text{HIZ}}$ are internally synchronized on consecutive falling and rising clocks before being used and must meet the specified setup and hold times to the falling edge of the clock only if recognition by a specific CLK falling edge is required.

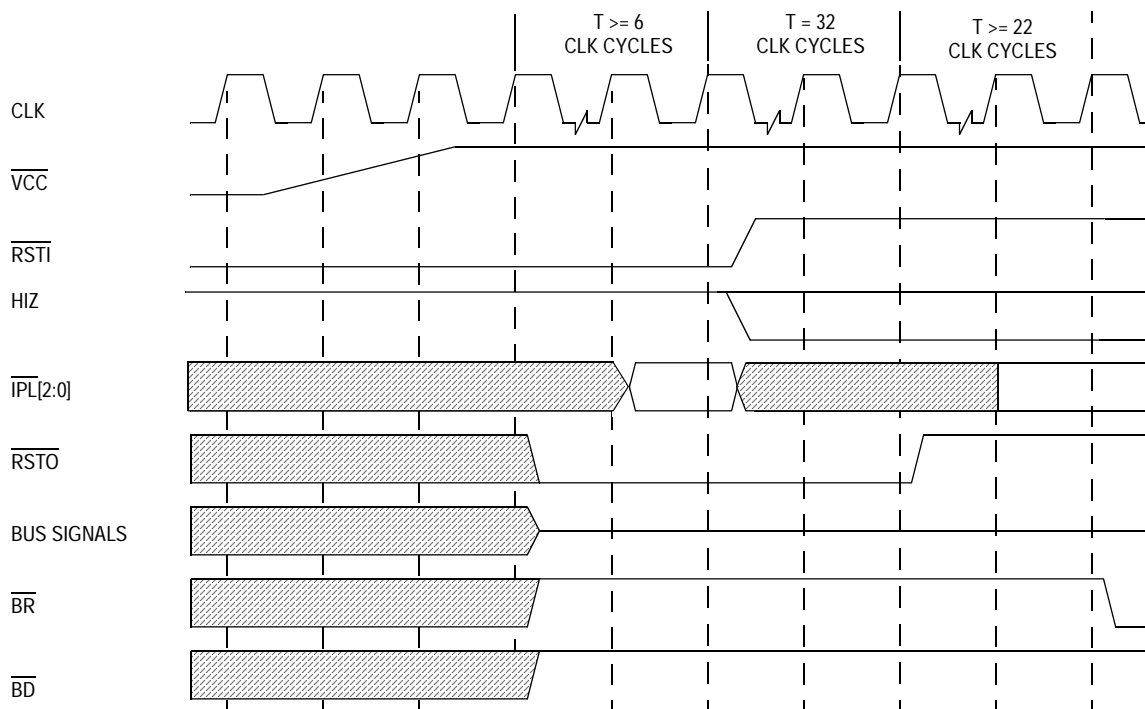

Figure 6-50. Normal Reset Timing

$\overline{\text{TS}}$ must be pulled up or negated during normal reset. When the assertion of $\overline{\text{RSTI}}$ is recognized internally, the MCF5206e asserts the reset out pin ($\overline{\text{RSTO}}$). $\overline{\text{RSTO}}$ is asserted as long as $\overline{\text{RSTI}}$ is asserted and remains asserted for 32 CLK cycles after $\overline{\text{RSTI}}$ is negated. For proper normal reset operation, $\overline{\text{HIZ}}$ must be negated as long as $\overline{\text{RSTI}}$ is asserted.

During the normal reset period, all signals that can be driven to a high-impedence state and all those that cannot are driven to their negated states. Once $\overline{\text{RSTI}}$ negates, all

bus signals continue to remain in a high-impedance state until the MCF5206e is granted the bus and the ColdFire core begins the first bus cycle for reset exception processing.

A normal reset causes all bus activity except DRAM refresh cycles to terminate. During a normal reset, DRAM refresh cycles continues to occur at the programmed rate and with the programmed waveform timing. In addition, normal reset initializes registers appropriately for a reset exception. During an external normal reset, the hard reset (HRST) bit in the Reset Status Register (RSR) is set and the software reset (SRST) bit in the Reset Status Register (RSR) is cleared to indicate an external hardware reset caused the previous reset.

The levels of the $\overline{\text{IPLx}}$ pins select the port size and acknowledge features of the global chip select after an external normal reset occurs. The $\overline{\text{IPLx}}$ signals are synchronized and are registered on the last falling edge of CLK where $\overline{\text{RSTI}}$ is asserted.

6.11.3 SOFTWARE WATCHDOG TIMER RESET OPERATION

If the software watchdog timer is programmed to generate a reset, when a timeout occurs an internal reset is asserted for at least 31 clocks, resetting internal registers as with a normal reset. The $\overline{\text{RSTO}}$

and after the software watchdog timeout reset at the programmed rate and with the programmed waveform timing.

\overline{TS} must be pulled up or negated during software watchdog reset. When the software watchdog timeout recognized internally, the reset out pin ($\overline{RTS2}/\overline{RSTO}$) is asserted by the MCF5206e. \overline{RSTO} is asserted for at least 31 CLK cycles after the internal software watchdog timer reset negated.

During the software watchdog timer reset period, all signals that can be driven to a high-impedance state and all those that cannot are driven to their negated states. Once \overline{RSTO} negates, all bus signals continue to remain in a high-impedance state until the MCF5206e is granted the bus and the ColdFire core begins the first bus cycle for reset exception processing.

A software watchdog timer reset causes all bus activity except DRAM refresh cycles to terminate. During a software watchdog timer reset, DRAM refresh cycles continue to occur at the programmed rate and with the programmed waveform timing. In addition, software watchdog timer reset initializes registers appropriately for a reset exception. During a software watchdog timer reset, the hard reset (HRST) bit in the Reset Status Register (RSR) is cleared and the software reset (SRST) bit in the Reset Status Register (RSR) is set to 1 to indicate that a software watchdog timeout caused the previous reset.

NOTE

The levels of the \overline{IPLx} pins are not sampled during a software watchdog reset. If the port size and acknowledge features of the global chip select are different from the values programmed in the Chip Select Control Register 0 (CSCR0) at the time of the software watchdog reset, you must assert \overline{RSTI} during software watchdog reset to cause the $\overline{IPLx}/\overline{IRQx}$ pins to be resampled.

SECTION 7

DMA CONTROLLER MODULE

7.1 INTRODUCTION

The Direct Memory Access Controller (DMA) Module provides a quick and efficient process for moving blocks of data with minimal processor overhead. The DMA module, shown in Figure 7-1, provides two channels that allow byte, word, or longword operand transfers. These transfers can be single or dual address to off-chip devices or dual address to on-chip devices.

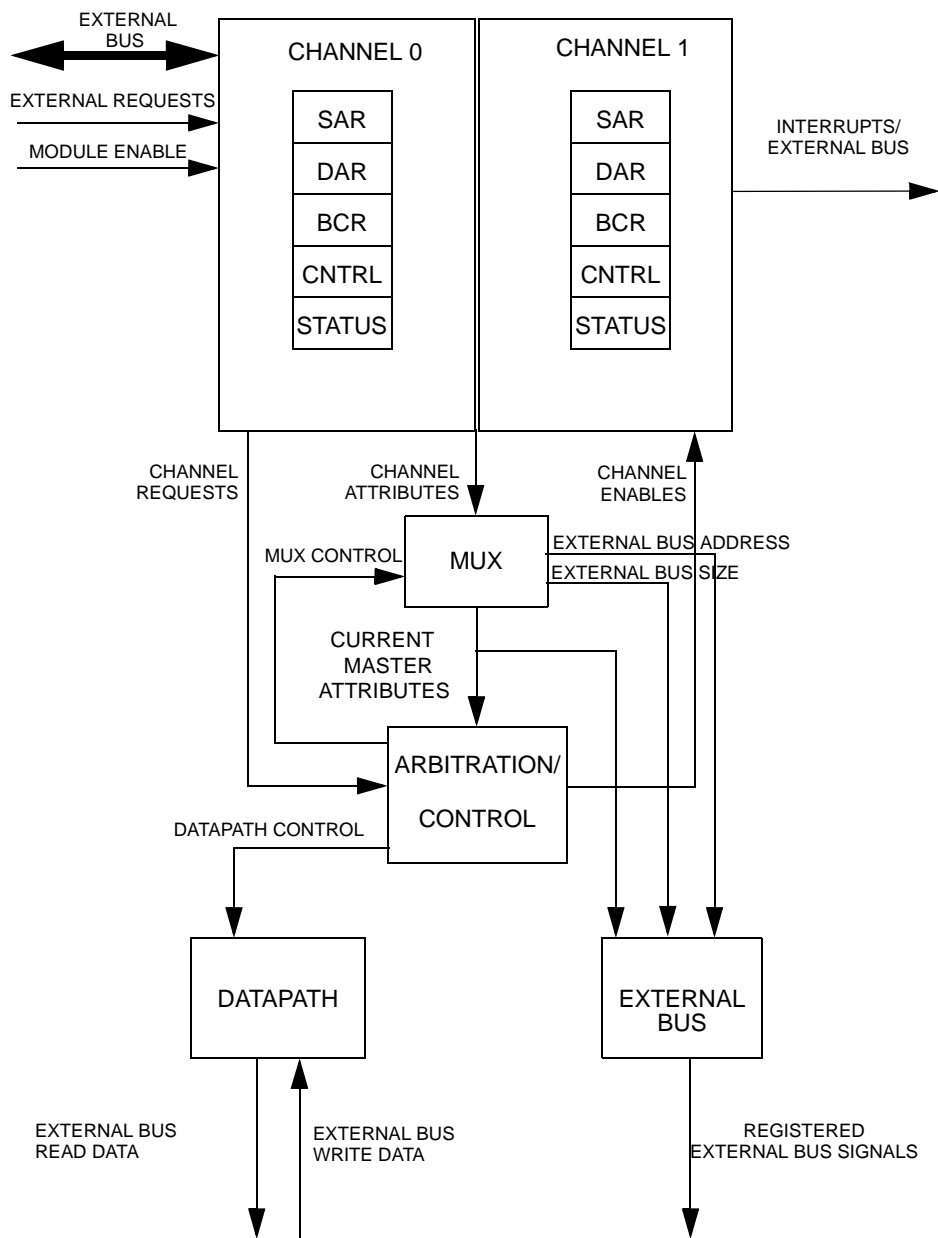

Figure 7-1. DMA Signal Diagram

The DMA contains the following features:

- Two fully independent programmable DMA Controller Module channels
- Auto-alignment feature for source or destination accesses
- Single and dual address transfers
- Two external request pins provided
- Channel arbitration on transfer boundaries

- Data transfers in 8-, 16-, 32- or 128-bit blocks via a 16-byte buffer
- Supports burst and cycle steal transfers
- Independent transfer widths for source and destination
- Independent source and destination address registers
- Provide two clock data transfers

7.2 DMA SIGNAL DESCRIPTION

This subsection contains a brief description of the DMA module signals used to provide handshake control for either a source or destination external device. See Table 7-1 for details.

Table 7-1. DMA Signals.

SIGNAL NAME	DIRECTION	DESCRIPTION
$\overline{\text{DREQ}}[1:0]$	In	External DMA request

7.2.1 DMA Request ($\overline{\text{DREQ}}[1]/\text{TOUT}[0]$ & $\overline{\text{DREQ}}[0]/\text{TIN}[0]$)

These multiplexed pins can serve as the DMA request inputs, or as Timer 0 input and output pins. Programming the Pin Assignment Register (PAR) in the SBC determines the function of each of these two multiplexed pins. The pins are programmable on a bit-by-bit basis.

These active-low inputs are asserted by a peripheral device to request an operand transfer between that peripheral and memory.

The $\overline{\text{DREQ}}$ signals are asserted to initiate DMA accesses in the respective channels. The system should force any unused $\overline{\text{DREQ}}$ signals to a logic high state.

7.3 DMA MODULE OVERVIEW

The DMA controller module transfers data at very high rates, usually much faster than the ColdFire core under software control can handle. The term DMA refers to a peripheral device's capability to access memory in a system in the same manner as a microprocessor does. DMA operations can greatly increase overall system performance.

The DMA module consists of two independent channels, each with independent request signals. The term DMA is used throughout this section to reference either of the two channels as they are functionally equivalent. However, both channels cannot own the bus at the same time. Therefore, it is impossible to implicitly address both DMA channels at the same time. The MCF5206e on-chip peripherals do not support the single-address transfer mode.

DMA requests may be internally generated by the processor writing to the start bit or externally generated by a device. The amount of bus bandwidth allocated for the DMA can be programmed by the processor for each channel. The DMA channels support two transfer modes: continuous mode and cycle steal mode.

The DMA controller supports single- and dual-address transfers. In single-address mode, a channel supports 32 bits of address and 32 bits of data. Single-address transfers can be started by an external device using the request signal. The DMA provides address and control signals during a single-address transfer. The requesting device either sends or receives data to or from the specified address (see Figure 7-2). In dual-address mode, a channel supports 32 bits of address and 32 bits of data. The dual-address transfers can be started by either the internal request mode or by an external device using the request signal. In this mode, two bus transfers occur, one from a source device and the other to a destination device (see Figure 7-3).

Any operation involving the DMA follows the same basic steps: channel initialization, data transfer, and channel termination. In the channel initialization step, the DMA channel registers are loaded with control information, address pointers, and a byte transfer count. The channel is then started. During the data transfer step, the DMA accepts requests for operand transfers and provides addressing and bus control for the transfers. The channel termination step occurs after operation is complete. The channel indicates the status of the operation in the channel status register.

NOTE:

The DMA cannot access the SRAM that is resident on-chip.

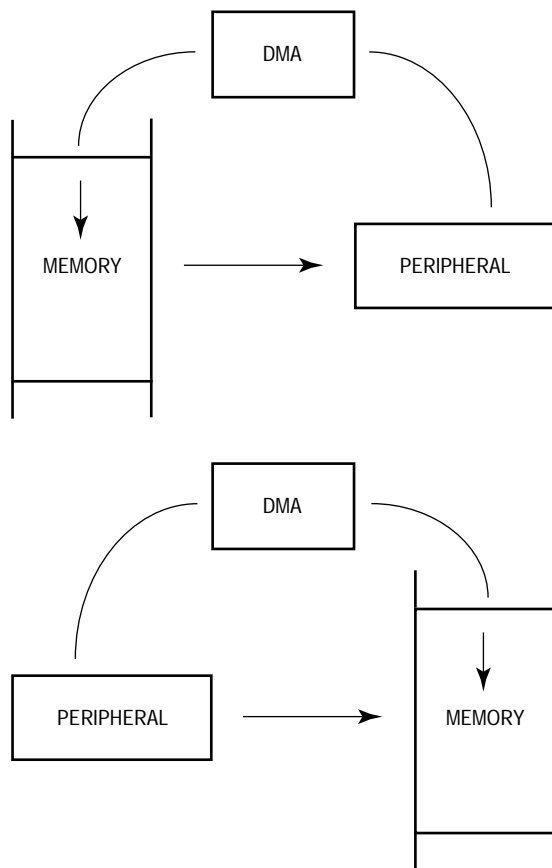

Figure 7-2. Single-Address Transfers

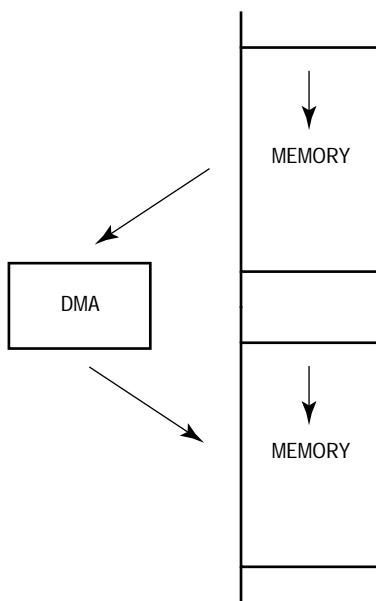

Figure 7-3. Dual-Address Transfers

7.4 DMA CONTROLLER MODULE PROGRAMMING MODEL

The registers of each DMA Controller Module channel are mapped into memory as shown in Figure 7-5. The base address for each channel of the DMA Controller Module is displayed in Table 7-7.

Base Address Offset	Channel
MBAR + DMA0SAR	Channel 0
MBAR + DMA1SAR	Channel 1

Table 7-2. DMA Controller Module Channel Offsets

The DMA Controller Module register set controls the DMA Controller Module. This section describes each of the internal registers and the bit assignment for each register. Note that there is no mechanism for the prevention of writes to control registers during DMA transfers.

Base Address Offset	[31:0]
\$200	Source Address Register 0
\$204	Destination Address Register 0
\$208	DMA Control Register 0
\$20C	Byte Count Register 0
\$210	Status Register 0
\$214	Interrupt Vector Register 0
\$240	Source Address Register 1
\$244	Destination Address Register 1
\$248	DMA Control Register 1
\$24C	Byte Count Register 1
\$250	Status Register 1
\$254	Interrupt Vector Register 1

Figure 7-4. DMA Controller Module Register Model Per Channel

7.4.1 Source Address Register (SAR)

The source address register (SAR) is a 32-bit register containing the address from which the DMA Controller Module will request data during a transfer. In Single Address Mode, the SAR provides the address regardless of the direction.

31	30	29	28	27	26	25	24	23	22	21	20	19	18	17	16
SAR31	SAR30	SAR29	SAR28	SAR27	SAR26	SAR25	SAR24	SAR23	SAR22	SAR21	SAR20	SAR19	SAR18	SAR17	SAR16
Reset:															
0	0	0	0	0	0	0	0	0	0	0	0	0	0	0	0
15	14	13	12	11	10	9	8	7	6	5	4	3	2	1	0
SAR15	SAR14	SAR13	SAR12	SAR11	SAR10	SAR9	SAR8	SAR7	SAR6	SAR5	SAR4	SAR3	SAR2	SAR1	SAR0
Reset:															
0	0	0	0	0	0	0	0	0	0	0	0	0	0	0	0

Source Address Register (SAR)

7.4.2 Destination Address Register (DAR)

The destination address register (DAR) is a 32-bit register containing the address to which the DMA Controller Module will send data during a transfer. Note that this register is only used during dual address transfers.

31	30	29	28	27	26	25	24	23	22	21	20	19	18	17	16
DAR31	DAR30	DAR29	DAR28	DAR27	DAR26	DAR25	DAR24	DAR23	DAR22	DAR21	DAR20	DAR19	DAR18	DAR17	DAR16
Reset:															
0	0	0	0	0	0	0	0	0	0	0	0	0	0	0	0
15	14	13	12	11	10	9	8	7	6	5	4	3	2	1	0
DAR15	DAR14	DAR13	DAR12	DAR11	DAR10	DAR9	DAR8	DAR7	DAR6	DAR5	DAR4	DAR3	DAR2	DAR1	DAR0
Reset:															
0	0	0	0	0	0	0	0	0	0	0	0	0	0	0	0

Destination Address Register (DAR)

7.4.3 Byte Count Register (BCR)

The byte count register (BCR) is a 16-bit register containing the number of bytes remaining to be transferred for a given block. The BCR count is the number of bytes remaining to be written.

The BCR decrements on the successful completion of the address phase of either a write transfer in dual address mode or any transfer in single address mode. The amount the BCR decrements is 1, 2, 4, or 16 for byte, word, longword, or line accesses, respectively.

15	14	13	12	11	10	9	8	7	6	5	4	3	2	1	0
BCR15	BCR14	BCR13	BCR12	BCR11	BCR10	BCR9	BCR8	BCR7	BCR6	BCR5	BCR4	BCR3	BCR2	BCR1	BCR0
Reset:															
0	0	0	0	0	0	0	0	0	0	0	0	0	0	0	0

Byte Count Register (BCR)

The DONE bit in the DMA Status Register is set when the entire block transfer is complete, when BCR = \$00.

When a transfer sequence is initiated and the BCR contains a value that is not divisible by 16, 4, or 2 when the DMA is configured for line, longword, or word transfers, respectively, the configuration error bit in the DMA status register (DSR) is set and the transfer is not performed.

BWC—Bandwidth Control

These three bits are decoded to provide for internal bandwidth control. When the byte count has reached the programmed BWC boundary, the request signal to the internal arbiter is negated until the completion of the data access to enable the ColdFire core to access the bus. Table 7-8 shows the encodings for these bits. When the bits are cleared, the DMA does not negate its request. The table shows BCR values at which the bus is relinquished. For example, if BWC = 001 and the BCR is set to 516, the bus is relinquished after four bytes are transferred.

Table 7-3. BWC Encoding

BWC	BLOCK SIZE
000	Bandwidth Control Disabled
001	512
010	1024
011	2048
100	4096
101	8192
110	16384
111	32768

SAA—Single Address Access

- 1 = The DMA channel is in single address mode. The DMA provides an address from the SAR and directional control, bit S_RW, to allow two peripherals (one may be memory) to exchange data within a single access. Data is not stored by the DMA.
- 0 = The DMA channel is in dual address mode.

S_RW—Single Address Access Read/Write Value.

This bit specifies the value of the external R/\overline{W} signal during single address accesses. This provides directional control to the master bus controller.

- 1 = Forces the external R/\overline{W} signal to a logic high state.
- 0 = Forces the external R/\overline{W} signal to a logic low state.

The bit is only valid when the SAA bit is set.

SINC—Source Increment

This bit controls whether the source address increments after each successful transfer.

- 1 = The SAR increments by 1, 2, 4, or 16, depending upon the size of the transfer.
- 0 = There is no change to the SAR after a successful transfer.

SSIZE—Source Size

This field controls the size of the source bus cycle that the DMA Controller Module is running. See Table 7-4 for the encoding of this field.

Table 7-4. SSIZE Encoding

SSIZE	TRANSFER SIZE
00	Longword
01	Byte
10	Word
11	Line

DINC—Destination Increment

This bit controls whether the destination address increments after each successful transfer.

- 1 = The DAR increments by 1, 2, 4, or 16 depending upon the size of the transfer.
- 0 = There is no change to the DAR after a successful transfer.

DSIZE—Destination Size

This field controls the size of the destination bus cycle that the DMA Controller Module is running. See Table 7-10 for the encoding of this field.

Table 7-5. DSIZE Encoding

DSIZE	TRANSFER SIZE
00	Longword
01	Byte
10	Word
11	Line

START—Start Transfer

- 1 = Indicates to the DMA to begin the transfer according to the values in the control registers.

This bit is self-clearing after one clock and is always read as a logic 0.

7.4.5 DMA Status Register (DSR)

The DMA Status Register (DSR) is an 8-bit register that reports on the status of the DMA Controller Module. On recognition of an event, the DMA Controller Module sets the corresponding bit in the DSR. Only writes to bit 0 of the DSR have any effect.

NOTE

Setting the DONE bit creates a single-cycle pulse, which will reset the channel thus clearing **all** bits in the register. This must be done at the completion of a transfer, though it may be set during a transfer to abort the transfer.

7	6	5	4	3	2	1	0
-	CE	BES	BED	-	REQ	BSY	DONE
Reset:							
-	0	0	0	-	0	0	0

DMA Status Register (DSR)

Bit 7—Reserved

CE—Configuration Error

A configuration error results when either the number of bytes represented by the BCR is not consistent with the requested source or destination transfer size, or the SAR or DAR contains an address that does not match the requested transfer size for the source or destination, respectively. The bit is cleared during a hardware reset, or by writing a logic one to the DONE bit of the DSR.

- 1 = A configuration error has occurred.
- 0 = No configuration error exists.

BES—Bus Error on Source

- 1 = The DMA channel has terminated with a bus error either during the read portion of a transfer or during an access in single address mode (SAA = 1).
- 0 = No bus error has occurred.

BED—Bus Error on Destination

- 1 = The DMA channel has terminated with a bus error during the write portion of a transfer.
- 0 = No bus error has occurred.

Bit 3 —Reserved

REQ—Request

- 1 = The DMA channel has transfers remaining and the channel is not selected
- 0 = There is no request pending or the channel is currently active. The bit is cleared when the channel is selected.

BSY—Busy

- 1 = This bit is set the first time the channel is enabled after a transfer is initiated.
- 0 = DMA channel is not active. This bit is cleared to 0 when the DMA has finished the last transaction.

DONE—Transaction Done

This bit may be read or written and is set when all DMA Controller Module transactions have completed normally, as determined by the transfer count or error conditions. When the BCR reaches zero, DONE is asserted by the DMA or a peripheral device at the successful conclusion of the final DMA Controller Module transfer.

This bit is written with a 1 to reset the DMA control/state bits and can be used in an interrupt handler to clear the DMA interrupt and the DONE and error bits. It can also be used to kill a transfer in progress by resetting state bits. Writing a 0 to this location has no affect.

- 1= DMA transfer is complete.
- 0= Writing or reading a 0 at this bit location has no affect.

7.4.6 DMA Interrupt Vector Register

The DMA Interrupt Vector Register (DIVR) is an 8-bit register, which is sent to the ColdFire core in response to an acknowledge cycle. The register is selected when both the $\overline{\text{SMEN}}$ and SIVOE signals are asserted.

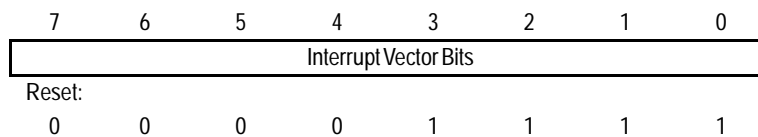

DMA Interrupt Vector Register (DIVR)

7.5 TRANSFER REQUEST GENERATION

The DMA channel supports two types of request generation methods: internal and external. Both types of requests can be programmed to limit the amount of bus use and can be either cycle-steal mode or continuous mode. The EEXT field in the DCR programs the request generation method used for the channel.

7.5.1 Cycle Steal Mode

When the CS field in the DCR is set, the DMA is in cycle-steal mode. This means that only one complete transfer from source to destination will take place for each request that the module receives. The request can be either internal or external depending on how the EEXT field is programmed.

NOTE:

When in cycle steal mode, the DMA channel is forced to give up the bus. If no external master is requesting the bus and the CPU is not requesting the bus, the lower priority channel will get 1 access to the bus before the higher priority channel gets it back. However, the more likely scenario that the CPU is also requesting access, the higher priority channel keeps ownership until the transfer is complete.

7.5.2 Continuous Mode

If the CS field in the DCR is cleared, the DMA is in continuous mode. After a request is asserted, either internal or external, the DMA continuously transfers data until the BCR is zero, the value in the BWC is reached, or the DONE bit in the DSR is set.

The continuous mode can be run at either the maximum rate or a limited rate. The maximum rate of transfer can be achieved if the BWC field in the DCR is programmed to be 000. Then the DMA channel that has started a transfer will continue until the BCR decrements to zero or a 1 is written to the DONE bit in the DSR.

A limited rate can be achieved by programming the BWC field to be anything except 000. The DMA then performs the specified number of transfers and surrenders the bus to allow another device to use the bus. In this mode, the DMA negates its internal bus request on the

last transfer before the boundary programmed in the BWC field. After the transfer is complete, it then asserts its internal bus request again to regain mastership at the earliest possible time as determined by the internal bus arbiter. The minimum amount of time that the DMA does not have the bus is one bus cycle.

7.6 DATA TRANSFER MODES

Each DMA channel supports single- and dual-address transfers. The single-address transfer mode consists of one DMA bus cycle, which allows either a read or a write cycle to occur. The dual-address transfer mode consists of a source operand read and a destination operand write.

7.6.1 Single Address Transactions

The DMA Controller Module begins a single address transfer sequence when the SAA bit is set while a DMA request is made. If no error conditions exist, the REQ bit is set. When the channel is enabled, the BSY bit is set and the REQ bit is cleared. The SAR contents are then driven onto the address bus and the value of the S_RW bit is driven onto the R/W signal. The BCR decrements on successful address phase accesses until it reaches 0, and the DONE bit is set.

In the event of a termination error, the BES and DONE bit of the DSR are set, and no further DMA Controller Module transactions are attempted.

7.6.2 Dual Address Transactions

The DMA Controller Module begins a dual-address transfer sequence when the SAA bit is cleared while a DMA request is made. If no error condition exists, the REQ bit of the DSR is set.

7.6.2.1 DUAL ADDRESS READS. The DMA Controller Module drives the value in the SAR onto the address bus. If the SINC bit of the DCR is set, then the SAR increments by the appropriate number of bytes upon a successful read cycle. When the appropriate number of read cycles completes successfully, the DMA initiates the write portion of the transfer.

In the event of a termination error, the BES and DONE bit of the DSR are set, and no further DMA Controller Module transactions are attempted.

7.6.2.2 DUAL ADDRESS WRITES. The DMA Controller Module drives the value in the DAR onto the address bus. If the DINC bit of the DCR is set, the DAR increments by the appropriate number of bytes at the completion of a successful write cycle. The BCR decrements by the appropriate number of bytes. If the BCR equals zero, the DONE bit is set. If the BCR is greater than 0, then another read/write transfer is initiated. If the BCR is a multiple of the programmed BWC, then the DMA request signal is negated until termination of the bus cycle, to allow the internal arbiter to return control to the ColdFire core. There is an idle clock before the next assertion of MTS.

In the event of a termination error, the BED and DONE bit of the DSR are set, and no further DMA Controller Module transactions are attempted.

7.7 DMA CONTROLLER MODULE FUNCTIONAL DESCRIPTION

In the following descriptions, “DMA request” implies that the START bit is set or the DREQ signal is asserted while the EEXT bit is set. The START bit is cleared when the channel begins an internal access. Before initiating a transfer request, the DMA Controller Module first verifies that the source size and destination size (dual address only) as configured in the DCR, are consistent with the source address and destination address. If a misalignment is detected, no transfer occurs, and the CE bit of the DSR is set. The CE bit is also set if the BCR contains a value inconsistent with both the destination size (dual address only) and the source size. Depending on the configuration of the DCR, an interrupt event may be issued when the CE bit is set. Note that if the AA bit is set, error checking is performed only on the appropriate registers.

A “read/write” transfer refers to a dual-address access in which a number of bytes are read from the source address and written to the destination address. The number of bytes transferred is determined by the larger of the sizes specified by the source and destination size encodings.

The source and destination address registers (SAR and DAR) increment at the completion of a successful address phase. The BCR decrements at the completion of a successful address phase write when SAA=0 or any successful address phase when SAA=1. A successful address phase occurs when a valid address request is not held by the arbiter.

7.7.1 Channel Initialization and Startup

Before starting a block transfer operation, the channel registers must be initialized with information describing the channel configuration, request generation method, and data block. This initialization is accomplished by programming the appropriate information into the channel registers.

7.7.1.1 CHANNEL PRIORITIZATION. Channel 0 has priority over Channel 1 unless overwritten by the BWC bits in channel 1’s DCR. If the BWC bits for DMA channel 1 are set to 000, then it will have priority over channel 0, unless channel 0 also has the BWC bits set to 000.

7.7.1.2 PROGRAMMING THE DMA CONTROLLER MODULE. Some general comments on programming the DMA follow:

- No mechanism exists for preventing writes to control registers during DMA accesses
- If the BWC of sequential channels are equivalent, channel priority is in ascending order

The SAR is loaded with the source (read) address. If the transfer is from a peripheral device to memory, the source address is the location of the peripheral data register. If the transfer is from memory to a peripheral device or memory to memory, the source address is the starting address of the data block. This address may be any byte address. In the single-address mode, this register is used regardless of the direction of the transfer.

The DAR should contain the destination (write) address. If the transfer is from a peripheral device to memory or memory to memory, the DAR is loaded with the starting address of the data block to be written. If the transfer is from memory to a peripheral device, the DAR is

loaded with the address of the peripheral data register. This address may be any byte address. In the single-address mode, this register is not used.

The manner in which the SAR and DAR change after each cycle depends on the values in the DCR SSIZE and DSIZE fields and the SINC and DINC bits, and the starting address in the SAR and DAR. If programmed to increment, the increment value is 1, 2, 4, or 16 for byte, word, longword, or line operands, respectively. If the address register is programmed to remain unchanged (no count), the register is not incremented after the operand transfer.

The BCR must be loaded with the number of byte transfers that are to occur. This register is decremented by 1, 2, 4, or 16 at the end of each transfer. The DSR must be cleared for channel startup.

Once the channel has been initialized, it is started by writing a one to the START bit in the DCR or asserting the DREQ signal, depending on the status of the EEXT bit in the DCR. Programming the channel for internal request causes the channel to request the bus and start transferring data immediately. If the channel is programmed for external request, DREQ must be asserted before the channel requests the bus.

If any fields in the DCR are modified while the channel is active, that change is effective immediately. To avoid any problems with changing the setup for the DMA channel, a 1 should be written to the DONE bit in the DSR to stop the DMA channel.

7.7.2 Data Transfers

7.7.2.1 EXTERNAL DMA REQUEST OPERATION. Each channel has the feature of interfacing to an external device to initiate transfers to the device. If the EEXT bit is set, when the DREQ signal asserts, the DMA initiates a transfer provided the channel is idle. If the CS (cycle steal) bit is set, then a single read/write transfer occurs. If the CS bit is clear, multiple read/write transfers occur as programmed. The DREQ signal is not required to be negated until the DONE bit of the DSR asserts. In cycle-steal mode, the maximum length of DREQ assertion to maintain a single transfer depends on configuration. In the worst case of a single-address access, byte accesses, and idle channels, DREQ may be asserted for no more than five rising clock edges (see Figure 7-5).

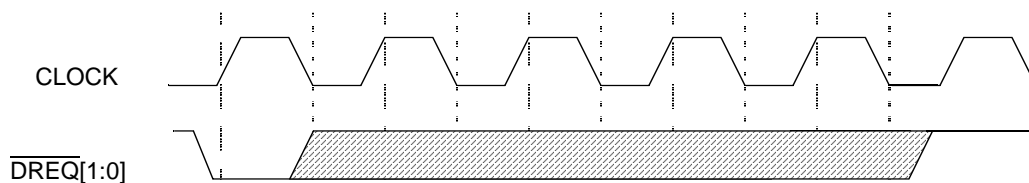

Figure 7-5. External Request Timing - Cycle Steal Mode, Single-Address Mode

See Figure 7-7 for timing relationships for a dual-address transfer using cycle-steal mode. The maximum assertion time for DREQ in this configuration is eight clocks.

NOTE:

You can DMA from on-chip serial ports using the UART interrupt signal as the source for external DMA requests ($\overline{\text{DREQ}}$). The mechanism to accomplish this is to configure the Pin Assignment Register (PAR) bits 8 & 9 to the timer function. By doing this, the DMA external request line is sourced from the UART interrupts. By setting up the UART to interrupt appropriately and by enabling external requests, the DMA can operate directly from the UARTs.

When an access occurs that was initiated by an $\overline{\text{DREQ}}$ signal, the transfer mode signals indicate a DMA cycle, while the transfer modifier signals will indicate that the cycle is due to an external request. To create an external DMA acknowledge signal, it may be necessary to decode the address of the peripheral along with a combination of the transfer mode and transfer type signals. To create an external DMA acknowledge signal for block transfers, you may count the transfers or compare the address to a stored final address to assert the DMA acknowledge to the peripheral.

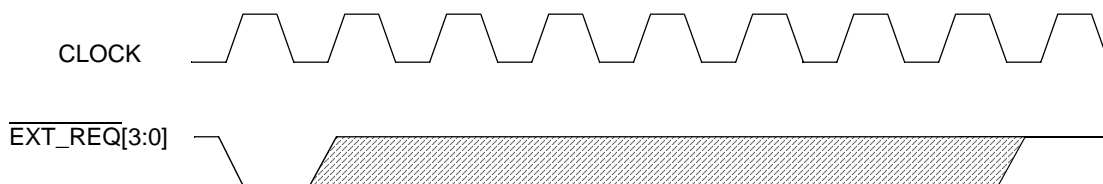

Figure 7-6. External Request Timing - Cycle Steal Mode, Dual Address Mode

7.7.2.2 AUTO-ALIGNMENT. This feature allows for block transfers to occur at the most optimum size possible based on the address, byte count, and programmed size. To use this feature, AA in the DCR must be set. The source is auto-aligned when the SSIZE bits indicate a larger transfer size compared to DSIZE. Source alignment takes precedence over the destination when the source and destination sizes are equal. Otherwise, the destination is auto-aligned. The address register that is chosen for alignment increments regardless of the value of the increment bit. Configuration error checking is performed on the registers that are not chosen for alignment.

If the BCR contains a value greater than 16, the address determines the size of the transfer. Single byte, word or longword transfers occur until the address is aligned to the programmed size boundary, at which time the programmed size accesses begin. When the BCR is less than 16 at the beginning of a read/write transfer, the number of bytes remaining will dictate the transfer size, longword, word or byte.

For example,

AA = 1, SAR = \$0001, BCR = \$00F0, SSIZE = 00 (longword) and DSIZE = 01 (byte),

Because the SSIZE > DSIZE, the source is auto-aligned. Error checking is performed on the destination registers. The sequence of accesses is as follows:

- Read byte from \$0001 - write byte, increment SAR
- Read word from \$0002 - write 2 bytes, increment SAR
- Read long word from \$0004 - write 4 bytes, increment SAR
- Repeat longwords until SAR = \$00F0
- Read byte from \$00F0 - write byte, increment SAR.

If DSIZE is set to another size, then the data writes are optimized to write the largest size allowed based on the address, but not exceeding the configured size.

NOTE

If AA is set, the BCR may skip over the programmed boundary.
In this case, the DMA master bus request will not negate.

7.7.2.3 BANDWIDTH CONTROL. This feature provides a mechanism that can force the DMA to relinquish control to the ColdFire core. The decode of the BWC provides 7 levels of block transfer sizes. If the BCR decrements to a value equivalent to the decode of the BWC, the DMA master bus request negates until termination of the bus cycle. The arbiter may then choose to switch the bus to another master, should a request be pending. If the BWC = 0, the request signal will remain asserted until the BCR reaches 0. In addition, an internal signal will assert to indicate that the channel has been programmed to have priority. Note that in this arbitration scheme, the arbiter always has the capability to force the DMA to relinquish the bus.

7.7.3 Channel Termination

7.7.3.1 ERROR CONDITIONS. When the DMA Controller Module encounters a read or write cycle that terminates with an error condition, the appropriate bit of the DSR is set, depending on whether the bus cycle was a read (BES) or a write (BED). The DMA transfers are then halted. If the error condition occurred during a write cycle, any data remaining in the internal holding register is lost.

7.7.3.2 INTERRUPTS. If the INT bit of the DCR is set, the DMA will drive the appropriate slave bus interrupt signal. A processor can then read the DSR to determine if the transfer terminated successfully or with an error. The DONE bit of the DSR is then written with a 1 to clear the interrupt, along with clearing the DONE and error bits.

SECTION 8

SYSTEM INTEGRATION MODULE

8.1 INTRODUCTION

This subsection details the operation and programming model of the System Integration Module (SIM) registers, including the interrupt controller and system-protection functions for the MCF5206e. The SIM provides overall control of the internal and external buses and serves as the interface between the ColdFire[®] core processor and the internal peripherals or external devices.

8.1.1 Features

The following list summarizes the key SIM features:

- Module Base Address Register (MBAR)
 - Base address location of all internal peripherals and SIM resources
 - Address space masking to internal peripherals and SIM resources
- Interrupt Controller
 - Programmable interrupt level (1-7) for internal peripheral interrupts
 - Programmable priority level (0-3) within each interrupt level
 - Three external interrupts - programmable as individual Interrupt Requests or as Interrupt Priority-Level signals
- System Protection
 - Reset status to indicate cause of last reset
 - Bus monitor and Spurious Interrupt Monitor
 - Software Watchdog Timer
- Internal Bus Arbitration
 - Arbitration for internal bus between ColdFire core processor and DMA modules

8.2 SIM OPERATION

8.2.1 Module Base Address Register (MBAR)

The MBAR determines the base address of all internal peripherals as well as the definition of which types of accesses are allowed for these registers.

The MBAR is a 32-bit write-only supervisor control register. It is accessed in the CPU address space \$C0F via the MOVEC instruction. (Refer to the *ColdFire Microprocessor*

Family Programmer's Reference Manual (MCF5200PRM/AD) for use of MOVEC instruction). The MBAR can be read when in debug mode using background debug commands.

At system reset, the MBAR valid bit is cleared to prevent incorrect references to resources before the MBAR is written. The remainder of the MBAR bits are uninitialized. To access the internal peripherals, you should write MBAR with the appropriate base address and set the valid bit after system reset.

All internal peripheral registers occupy a single relocatable memory block along 1 KByte boundaries. If the MBAR valid bit is set, the base address field is compared to the upper 22 bits of the full 32-bit internal address to determine if an internal peripheral is being accessed. The MBAR masks specific address spaces using the address space fields. Any attempt to access a masked address space results in an access being generated on the external bus.

8.2.2 Bus Timeout Monitor

The bus monitor ensures that each external cycle terminates within a programmed period of time. It continually checks the external bus for termination and asserts the internal transfer error acknowledge that results in an access fault exception if the response time is greater than the programmed bus monitor time. If a transfer is in progress while \overline{TEA} is asserted, the transfer is aborted and the exception will occur.

You can program the bus monitor time to 128, 256, 512, or 1024 clock cycles using the bus monitor timing bits in the system protection control register (SYPCR). The value you select should be larger than the longest possible response time of the slowest peripheral of the system. The bus time-out monitor begins counting on the clock cycle \overline{TS} is asserted and stops counting on the clock after the assertion of the final transfer termination signal (i.e., for a line transfer to a 32-bit port, the bus time-out monitor starts counting on the clock \overline{TS} is asserted and stops counting after \overline{TA} and/or \overline{ATA} have been asserted a total of four times).

The bus monitor enable bit in the SYPCR enables the bus monitor for external bus cycles. The bus monitor cannot be disabled for internal bus cycles to internal peripherals. Once the SYPCR is written using the MOVEC instruction, the state of the bus time-out monitor cannot be changed—the SYPCR may be written only once. Refer to subsection **8.3.2.7 System Protection Control register (SYPCR)** for programming information.

8.2.3 Spurious Interrupt Monitor

The SIM automatically generates the spurious interrupt vector number 24 (\$18), which causes the ColdFire core processor to terminate the cycle with a spurious interrupt exception if:

- An external device responds to an interrupt acknowledge cycle by asserting \overline{TEA}
- No interrupt is pending for the interrupt level being acknowledged when the interrupt acknowledge cycle is generated

NOTE

If an external device does not respond to an interrupt acknowledge cycle by asserting \overline{TA} or \overline{ATA} , an access error exception will be generated, not a spurious interrupt exception. To generate a spurious interrupt exception, \overline{TEA} would have to be generated.

8.2.4 Software Watchdog Timer

The software watchdog timer (SWT) prevents system lockup in case the software becomes trapped in loops with no controlled exit. The SWT can be enabled via the software watchdog enable bit in the SYPCR. If enabled, the SWT requires a special service sequence execution on a periodic basis. If this periodic servicing action does not occur, the SWT times out and results in a hardware reset or a level 7 interrupt, as programmed by the software watchdog reset/interrupt select bit in the SYPCR. If the SWT times out and is programmed to generate a hardware reset, an internal reset will be generated and the software watchdog timer reset bit in the reset status register is set. Additionally, if the $\overline{RTS2}/\overline{RSTO}$ pin is programmed for \overline{RSTO} , \overline{RSTO} is asserted for 32 CLK cycles. Refer to subsection **8.3.2.10 Pin Assignment Register (PAR)** for more information on programming.

The 8-bit interrupt vector for the SWT interrupt is stored in the software watchdog interrupt vector register (SWIVR). The software watchdog prescaler (SWP) and software watchdog

All interrupt inputs are level sensitive. An interrupt request must be held valid for at least two consecutive CLK periods to be considered a valid input. The three external interrupt inputs can be programmed to be three individual interrupt inputs (at level 1, 4, and 7) or encoded interrupt priority levels.

NOTE

If the external interrupt inputs are programmed to individual interrupt requests (at level 1, 4, and 7), the interrupt request must be asserted until the MCF5206e acknowledges the interrupt (by generating an interrupt acknowledge cycle) to guarantee that the interrupt is recognized.

If the external interrupt inputs are programmed to be interrupt priority levels, the interrupt request must maintain the interrupt request level or a higher priority level request until the MCF5206e acknowledges the interrupt to guarantee that the interrupt is recognized.

When the external interrupts are programmed to be individual $\overline{\text{IRQ}}$ interrupts in the Pin Assignment Register (PAR), the interrupt level bits in the appropriate ICRs of the external interrupts are not user-programmable and are always set to 1, 4, and 7. The value of the interrupt level bits in the ICRs for the external interrupts cannot be changed, even by a write to the register.

If the external interrupts are programmed to be encoded interrupt priority levels, the interrupt level is that indicated as shown in Table 8-1.

Table 8-1. Interrupt Levels for Encoded External Interrupts

$\overline{\text{IPL}}[2]/\overline{\text{IRQ}}[7]$	$\overline{\text{IPL}}[1]/\overline{\text{IRQ}}[4]$	$\overline{\text{IPL}}[0]/\overline{\text{IRQ}}[1]$	INTERRUPT LEVEL INDICATED
0	0	0	7
0	0	1	6
0	1	0	5
0	1	1	4
1	0	0	3
1	0	1	2
1	1	0	1
1	1	1	No Interrupt

Although the interrupt levels of the external interrupts are fixed, customers can program the interrupt priorities of the external interrupts to any value using the IP (IP1, IP0) bits in the corresponding interrupt control registers (ICR7 - ICR1). You can program the autovector bits in the interrupt control registers and you should program them to 1 when autovector generation is preferred.

NOTE

When an autovectored interrupt occurs, the interrupt is serviced internally. No external IACK cycle occurs.

The Software Watchdog Timer (SWT) has a fixed interrupt level (level 7). The interrupt priority of the SWT can be programmed to any value using the IP (IP1, IP0) bits in the SWT interrupt control register, ICR8. You cannot program the SWT to generate an autovector. The autovector bit in ICR8 is reserved and is always set to zero. The value of the software watchdog interrupt vector register is always be used as the interrupt vector number for a SWT interrupt.

You can program the timer modules' interrupt levels and priorities using the interrupt level (IL2 - IL0) and interrupt priority (IP1, IP0) bits in the appropriate interrupt control registers (ICR9, ICR10). The timer peripherals cannot provide interrupt vectors. Thus, autovector bits in ICR9 and ICR10 are always set to 1. This generates autovectors in response to all timer interrupts.

You can also program the MBUS module interrupt level and priority using the interrupt level (IL2 - IL0) and interrupt priority (IP1, IP0) bits in the MBUS interrupt control register, ICR11. You cannot program the MBUS module to provide an interrupt vector. Thus, the autovector bit in ICR11 is always set to 1. This generates an autovector in response to an MBUS interrupt.

You can program the UART modules' interrupt levels and priorities using the interrupt level (IL2 - IL0) and interrupt priority (IP1, IP0) bits in the appropriate interrupt control registers (ICR12, ICR13). In addition, you can program the autovector bits in ICR12 and ICR13. If the autovector bit is set to 0, you must program the interrupt vector register in each UART module to the preferred vector number.

The interrupt controller monitors and masks individual interrupt inputs and outputs the highest priority unmasked pending interrupt to the ColdFire core. Each interrupt input has a mask bit in the Interrupt Mask Register (IMR) and a pending bit in the interrupt pending register (IPR). The pending bits for all internal interrupts in the interrupt pending register are set the CLK cycle after the interrupt is asserted whether or not the interrupt is masked. If you program the external interrupt inputs as individual interrupt inputs, the pending bits in the interrupt pending register are set to the CLK cycle after the interrupt is asserted and internally synchronized.

If you program the external interrupt inputs to indicate interrupt priority levels, the interrupt pending bits are set and cleared as follows:

1. The interrupt pending bits, EINT[7:1] are set to the CLK cycle after the interrupt level has been internally synchronized and indicated the same valid level for two consecutive CLK cycles.
2. EINT[7:1] remains set if the external interrupt level remains the same or increases in priority.
3. The interrupt pending bits EINT[7:1] are cleared if the external interrupt level decreases in priority or if an interrupt acknowledge cycle is completed for an external interrupt that is pending but is not the current level being driven onto the external interrupt priority level signals (IPLx/IRQx).

You can assign as many as four interrupts to the same interrupt level, but you must assign unique interrupt priorities. The interrupt controller uses the interrupt priorities during an interrupt acknowledge cycle to determine which interrupt is being acknowledged. The interrupt priority bits determine the appropriate interrupt being acknowledged when multiple interrupts are assigned to the same level and are pending when the interrupt-acknowledge cycle is generated.

NOTE

You should not program interrupts to have the same level and priority. Interrupts can have the same level but different priorities. All level and priority combinations must be unique.

If an external interrupt request is being acknowledged and the AVEC bit in the corresponding ICR is not set, an external interrupt acknowledge cycle occurs. During an external interrupt acknowledge cycle, TT[1:0] and A[27:5] are driven high; A[4:2] are set to the interrupt level being acknowledged; and A[1:0] are driven low. Additionally, ATM is asserted when \overline{TS} is asserted and ATM is negated when \overline{TS} is negated. For nonautovector responses, the external device places the vector number on D[31:24]. For autovector responses, the autovector is generated internally and no external interrupt acknowledge cycle is run.

An interrupt request from the SWT does not require an external interrupt acknowledge cycle because SWIVR stores its interrupt vector number.

If an internal peripheral interrupt source is being acknowledged and the AVEC bit in the corresponding ICR is cleared, an internal interrupt-acknowledge cycle occurs with the internal peripheral supplying the interrupt vector number. If the corresponding AVEC bit is set, an internal interrupt-acknowledge cycle run but the SIM internally generates an autovector. No external interrupt acknowledge cycle is run.

8.3 PROGRAMMING MODEL

8.3.1 SIM Registers Memory Map

Table 8-2 shows the memory map of all the SIM registers. The internal registers in the SIM are memory-mapped registers offset from the MBAR address pointer. The following list addresses several key notes regarding the programming model table:

- The Module Base Address Register can only be accessed in supervisor mode using the MOVEC instruction with an Rc value of \$C0F.
- Underlined registers are status or event registers.
- Addresses not assigned to a register and undefined register bits are reserved for future expansion. Write accesses to these reserved address spaces and reserved register bits have no effect; read accesses returns zeros.
- The reset value column indicates the register initial value at reset. Certain registers may be uninitialized at reset.

- The access column indicates if the corresponding register allows both read/write functionality (R/W), read-only functionality (R), or write-only functionality (W). An attempted read access to a write-only register returns zeros. An attempted write access to a read-only register is ignored and no write occurs.

Table 8-2. Memory Map of SIM Registers

ADDRESS	NAME	WIDTH (BITS)	DESCRIPTION	RESET VALUE	ACCESS
MOVEC with \$C0F	MBAR	32	Module Base Address Register	uninitialized (except V=0)	W
MBAR + \$003	SIMR	8	SIM Configuration Register	\$C0	R/W
MBAR + \$014	ICR1	8	Interrupt Control Register 1 - External IRQ1/IPL1	\$04	R/W
MBAR + \$015	ICR2	8	Interrupt Control Register 2 - External IPL2	\$08	R/W
MBAR + \$016	ICR3	8	Interrupt Control Register 3 - External IPL3	\$0C	R/W
MBAR + \$017	ICR4	8	Interrupt Control Register 4 - External IRQ4/IPL4	\$10	R/W
MBAR + \$018	ICR5	8	Interrupt Control Register 5 - External IPL5	\$14	R/W
MBAR + \$019	ICR6	8	Interrupt Control Register 6 - External IPL6	\$18	R/W
MBAR + \$01A	ICR7	8	Interrupt Control Register 7 - External IRQ7/IPL7	\$1C	R/W
MBAR + \$01B	ICR8	8	Interrupt Control Register 8 - SWT	\$1C	R/W
MBAR + \$01C	ICR9	8	Interrupt Control Register 9 - Timer 1 Interrupt	\$80	R/W
MBAR + \$01D	ICR10	8	Interrupt Control Register 10 - Timer 2 Interrupt	\$80	R/W
MBAR + \$01E	ICR11	8	Interrupt Control Register 11 - MBUS Interrupt	\$80	R/W
MBAR + \$01F	ICR12	8	Interrupt Control Register 12 - UART 1 Interrupt	\$00	R/W
MBAR + \$020	ICR13	8	Interrupt Control Register 13 - UART 2 Interrupt	\$00	R/W
MBAR + \$021	ICR14	8	Interrupt Control Register 14 - DMA Channel 0 Interrupt	\$00	R/W
MBAR + \$022	ICR15	8	Interrupt Control Register 15 - DMA Channel 1 Interrupt	\$00	R/W
MBAR + \$036	IMR	16	Interrupt Mask Register	\$3FFE	R/W
MBAR + \$03A	IPR	16	Interrupt Pending Register	\$0000	R
MBAR + \$040	RSR	8	Reset Status Register	\$80 or \$20	R/W
MBAR + \$041	SYPCR	8	System Protection Control Register	\$00	R/W
MBAR + \$042	SWIVR	8	Software Watchdog Interrupt Vector Register	\$0F	R/W
MBAR + \$043	SWSR	8	Software Watchdog Service Register	uninitialized	W
MBAR + \$0CA	PAR	16	Pin Assignment Register	\$0000	R/W

8.3.2 SIM Registers

8.3.2.1 MODULE BASE ADDRESS REGISTER (MBAR). The MBAR determines the base address location of all internal module resources such as registers as well as the definition of the types of accesses that are allowed for these resources.

The MBAR is a 32-bit write-only supervisor control register that physically resides in the SIM. It is accessed in the CPU address space via the MOVEC instruction with an Rc encoding of \$C0F. The MBAR can be read and written to when in Background Debug mode (BDM). At system reset, the V bit is cleared and the remainder of the MBAR bits are uninitialized. To access the internal modules, MBAR should be written with the appropriate base address after system reset.

Module Base Address Register (MBAR)

31	30	29	28	27	26	25	24	23	22	21	20	19	18	17	16
BA31	BA30	BA29	BA28	BA27	BA26	BA25	BA24	BA23	BA22	BA21	BA20	BA19	BA18	BA17	BA16
RESET:	-	-	-	-	-	-	-	-	-	-	-	-	-	-	-
15	14	13	12	11	10	9	8	7	6	5	4	3	2	1	0
BA15	BA14	BA13	BA12	BA11	BA10	-	-	-	-	-	SC	SD	UC	UD	V
RESET:	-	-	-	-	-	0	0	0	0	0	-	-	-	-	0

BA[31:10] - Base Address

This field defines the base address location of all internal modules and SIM resources.

SC, SD, UC, UD - Address Space Masks

This field enables or disables specific address spaces, placing the internal modules in a specific address space. If an address space is disabled, an access to the register location in that address space becomes an external bus access, and the module resource is not accessed. The address space mask bits are

- SC = Supervisor code address space mask
- SD = Supervisor data address space mask
- UC = User code address space mask
- UD = User data address space mask

For each address space bit:

- 0= An access to the internal module can occur for this address space.
- 1= Disable this address space from the internal module selection. If this address space is used, no access occurs to the internal peripheral; instead, an external bus cycle is generated.

V - Valid

This bit indicates when the contents of the MBAR are valid. The base address value is not used, and all internal modules are not accessible until the V bit is set. An external bus cycle is generated if the base address field matches the internal core address, and the V bit is clear.

- 0 = Contents of MBAR are not valid.
- 1 = Contents of MBAR are valid.

8.3.2.2 SIM CONFIGURATION REGISTER (SIMR). The SIMR has user- programmable bits to control the following:

- Operation of software watchdog timer when the internal freeze signal is asserted

- Operation of bus time-out monitor when the internal freeze signal is asserted
- Operation of bus lock.

The internal freeze signal is asserted when the core processor has entered into Background Debug mode (BDM) for software development purposes.

The SIMR is an 8-bit read-write register. At system reset, FRZ1 and FRZ0 are set to 1 and BL is set to 0.

SIM Configuration Register(SIMR)					Address MBAR + \$03		
7	6	5	4	3	2	1	0
FRZ1	FRZ0	-	-	-	-	-	BL
RESET:							
1	1	0	0	0	0	0	0
R/W							

FRZ1 - Freeze Software Watchdog Timer Enable

- 0 = When the internal freeze signal is asserted, the software watchdog timer continues to run.
- 1 = When the internal freeze signal is asserted, the software watchdog timer is disabled.

FRZ0 - Freeze Bus Timeout Monitor Enable

- 0 = When the internal freeze signal is asserted, the bus timeout monitor continues to run.
- 1 = When the internal freeze signal is asserted, the bus timeout monitor is disabled.

BL - Bus Lock Enable

Bus lock enable lets customers control the assertion and negation of the bus driven (\overline{BD}) signal. Refer to the Bus Operation section for more information.

- 0 = Bus Driven (\overline{BD}) signal is negated by the MCF5206e and the bus is released when bus grant (\overline{BG}) is negated and the current bus cycle is completed.
- 1 = Once bus grant (\overline{BG}) is asserted, the bus driven (\overline{BD}) signal is asserted and can not be cleared until the BL bit is cleared.

8.3.2.3 INTERRUPT CONTROL REGISTER (ICR). The ICR contains the interrupt levels and priorities assigned to each interrupt input. There is one ICR for each interrupt input. Table 8-3 indicates the interrupt control register assigned to each interrupt input, the interrupt control register reset value, and the value of the interrupt level assigned. Each interrupt input must have a unique interrupt level and interrupt priority combination.

NOTE

The interrupt control registers do not have valid interrupt level/ interrupt priority combinations out of reset. You must program all interrupt control registers before programming the interrupt mask register (IMR). If you program the external interrupt inputs to be individual interrupts at level 1, 4 and 7, then ICR2, ICR3, ICR5 and ICR6 are not used.

Table 8-3. Interrupt Control Register Assignments

INTERRUPT SOURCE	INTERRUPT CONTROL REGISTER (ICR)	ICR RESET VALUE	ICR INTERRUPT LEVEL (IL2 - IL0) VALUE
External Interrupt Request 1 External Interrupt Priority Level 1	ICR1	\$04	\$1
External Interrupt Priority Level 2	ICR2	\$08	\$2
External Interrupt Priority Level 3	ICR3	\$0C	\$3
External Interrupt Request 4 External Interrupt Priority Level 4	ICR4	\$10	\$4
External Interrupt Priority Level 5	ICR5	\$14	\$5
External Interrupt Priority Level 6	ICR6	\$18	\$6
External Interrupt Request 7 External Interrupt Priority Level 7	ICR7	\$1C	\$7
Software Watchdog Timer	ICR8	\$1C	\$7
Timer 1	ICR9	\$80	User Programmable
Timer 2	ICR10	\$80	User Programmable
MBUS (I ² C)	ICR11	\$80	User Programmable
UART 1	ICR12	\$00	User Programmable
UART 2	ICR13	\$00	User Programmable
DMA 0	ICR14	\$00	User Programmable
DMA 1	ICR15	\$00	User Programmable

The ICRs are 8-bit read-write registers. See Table 8-3 for the reset values of each ICR.

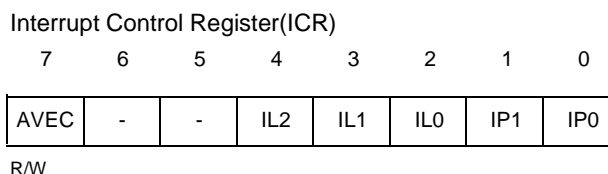

AVEC - Autovector Enable

This bit determines if the interrupt acknowledge cycle for the interrupt level indicated in IL2-IL0 for each interrupt input requires an autovector response. If this bit is set, a vector number is internally generated, which is the sum of the interrupt level, IL2-IL0, plus 24. Seven distinct autovectors can be used corresponding to the seven levels of interrupt. If this bit is clear, the external device or internal module must return the vector number during an interrupt acknowledge cycle.

NOTE

For the SWT, the corresponding AVEC is a reserved bit and set to zero, disabling autovector generation in response to SWT generated interrupts. The SWT returns the interrupt vector in SWIVR. The AVEC bits in the interrupt control registers for the timers and MBUS peripherals are reserved and are always set to 1. The autovector value is generated for each of these interrupts.

- 0 = Interrupting source returns vector number during the interrupt-acknowledge cycle.
- 1 = SIM internally generates vector number during the interrupt-acknowledge cycle.

IL[2:0] - Interrupt Level

These bits indicate the interrupt level assigned to each interrupt input. Level 7 is the highest priority, level 1 is the lowest, and level 0 indicates that no interrupt is requested. For external interrupts and SWT, the corresponding IL2-IL0 are reserved bits. If the ICRs are programmed to have nonunique interrupt level and priority combination, unpredictable results could occur.

NOTE

You should not program interrupts with the same level and priority. Interrupts can have the same level but different priorities. All level and priority combinations must be unique.

IP[1:0]- Interrupt Priority

These bits indicate the priority within an interrupt level assigned to each interrupt. You can assign as many as four interrupts to the same interrupt level as long as they have unique interrupt priorities. IP1-IP0 = 3 is the highest priority, and IP1-IP0 = 0 is the lowest priority for a given interrupt level. If you program the ICRs to have nonunique interrupt level and priority combination, unpredictable results could occur.

8.3.2.4 INTERRUPT MASK REGISTER (IMR). Each bit in the IMR corresponds to an interrupt source. Table 8-4 indicates which mask bit is assigned to each of the interrupt inputs.

You can mask an interrupt by setting the corresponding bit in the IMR and enable an interrupt by clearing the corresponding bit in the IMR. When a masked interrupt occurs, the corresponding bit in the IPR is still set, regardless of the setting of the IMR bit, but no interrupt request is passed to the core processor.

Table 8-4. Interrupt Mask Register Bit Assignments

INTERRUPT SOURCE	INTERRUPT MASK REGISTER BIT LOCATION
External Interrupt Request 1 External Interrupt Priority Level 1	1
External Interrupt Priority Level 2	2
External Interrupt Priority Level 3	3
External Interrupt Request 4 External Interrupt Priority Level 4	4
External Interrupt Priority Level 5	5
External Interrupt Priority Level 6	6
External Interrupt Request 7 External Interrupt Priority Level 7	7
Software Watchdog Timer	8
Timer 1	9
Timer 2	10
MBUS (I ² C)	11
UART 1	12
UART 2	13
DMA 0	14
DMA 1	15

The IMR is a 16-bit read/write register. At system reset, all unreserved bits are initialized to one.

Interrupt Mask Register(IMR)															Address MBAR + \$36
15	14	13	12	11	10	9	8	7	6	5	4	3	2	1	0
DMA 1	DMA 0	UART 2	UART 1	MBUS	TIMER 2	TIMER 1	SWT	EINT7	EINT6	EINT5	EINT4	EINT3	EINT2	EINT1	-
RESET: 0	0	1	1	1	1	1	1	1	1	1	1	1	1	1	0
R/W															

8.3.2.5 INTERRUPT PENDING REGISTER (IPR). Each bit in the IPR corresponds to an interrupt source. Table 8-5 indicates which pending bit is assigned to each of the interrupt inputs.

Table 8-5. Interrupt Pending Register Bit Assignments

INTERRUPT SOURCE	INTERRUPT PENDING REGISTER BIT LOCATION
External Interrupt Request 1 External Interrupt Priority Level 1	1
External Interrupt Priority Level 2	2
External Interrupt Priority Level 3	3
External Interrupt Request 4 External Interrupt Priority Level 4	4
External Interrupt Priority Level 5	5
External Interrupt Priority Level 6	6
External Interrupt Request 7 External Interrupt Priority Level 7	7
Software Watchdog Timer	8
Timer 1	9
Timer 2	10
MBUS (I ² C)	11
UART 1	12
UART 2	13
DMA 0	14
DMA 1	15

When an interrupt is received, the interrupt controller sets the corresponding bit in the IPR. For internal peripherals the corresponding bit in the IPR is set the CLK cycle after the internal interrupt is asserted and is cleared when the internal interrupt is cleared. If the external interrupts are programmed to be individual interrupts, the corresponding EINT bit is set the CLK cycle after the external interrupt is internally synchronized and is cleared when the external interrupt is cleared. If the external interrupts are programmed to be encoded interrupt priority interrupts, the IPR bit will be set the CLK after the external interrupt is internally synchronized and has been present for two CLK cycles. The IPR bit is cleared if

- The encoded interrupt priority level being driven on interrupt pins decreases in priority
- An interrupt acknowledge cycle is completed for an external interrupt that is not the external interrupt level indicated on the external interrupt priority level signals.

The IPR bit is cleared at the end of the interrupt acknowledge cycle. You cannot write to the IPR to clear any of the IPR bits.

An active interrupt request appears as a set bit in the IPR, regardless of the setting of the corresponding mask bit in the IMR.

The IPR is a 16-bit read-only register. At system reset, all bits are initialized to zero.

Interrupt Pending Register (IPR)															Address MBAR + \$3A
15	14	13	12	11	10	9	8	7	6	5	4	3	2	1	0
DMA 1	DMA 0	UART 2	UART 1	MBUS	TIMER 2	TIMER 1	SWT	EINT7	EINT6	EINT5	EINT4	EINT3	EINT2	EINT1	-
RESET:															
0	0	0	0	0	0	0	0	0	0	0	0	0	0	0	0
Read Only															

8.3.2.6 RESET STATUS REGISTER (RSR). The RSR contains a bit for each reset source to the SIM. A set bit indicates the last type of reset that occurred. The RSR is updated by the reset control logic when the reset is complete. Only one bit is set at any one time in the RSR. You can clear this register by writing a one to that bit location; writing a zero has no effect.

The RSR is an 8-bit read-write register.

HRST	-	SWTR	-	-	-	-	-
------	---	------	---	---	---	---	---

HRST - Hard Reset or System Reset

1 = The last reset was caused by an external device driving \overline{RSTI} . Assertion of reset by an external device causes the core processor to take a reset exception. All registers in internal peripherals and the SIM are reset.

SWTR - Software Watchdog Timer Reset

1 = The last reset was caused by the software watchdog timer. If SWRI in the SYPCR is set and the software watchdog timer times out, a hard reset occurs. \overline{RSTO} is asserted as an output.

8.3.2.7 SYSTEM PROTECTION CONTROL REGISTER (SYPCR). The SYPCR controls the software watchdog timer and bus timeout monitor enables and time-out periods.

The SYPCR is an 8-bit read-write register. The register can be read at anytime, but can be written only once after system reset. Subsequent writes to the SYPCR has no effect. At system reset, the software watchdog timer and the bus timeout monitor are disabled.

System Protection Control Register(SYPCR)					Address MBAR + \$41		
7	6	5	4	3	2	1	0
SWE	SWRI	SWP	SWT1	SWT0	BME	BMT1	BMT0
RESET:							
0	0	0	0	0	0	0	0

R/Write Once

SWE - Software Watchdog Enable

- 0 = Disable the software watchdog timer
- 1 = Enable the software watchdog timer

SWRI - Software Watchdog Reset/Interrupt Select

- 0 = Software watchdog timeout generates a level 7 interrupt to the core processor
- 1 = Software watchdog timeout generates an internal reset and RSTO is asserted

NOTE

If SWRI is set to 1, you must set bit 7 in the pin assignment register (PAR) to have RSTO asserted at the pin during a software watchdog timer-generated reset. See subsection **8.3.2.10 Pin Assignment Register (PAR)** for programming information.

SWP - Software Watchdog Prescalar

- 0 = Software watchdog timer clock is not prescaled
- 1 = Software watchdog timer clock is prescaled by a value of 512

SWT[1:0] - Software Watchdog Timing

These bits (along with the SWP bit) select the timeout period for the software watchdog timer as shown in Table 8-6. At system reset the software watchdog timing bits are set to the

minimum timeout period.

Table 8-6. SWT Timeout Period

SWP	SWT[1:0]	SWT TIMEOUT PERIOD
0	00	2^9 / System Frequency
0	01	2^{11} / System Frequency
0	10	2^{13} / System Frequency
0	11	2^{15} / System Frequency
1	00	2^{18} / System Frequency
1	01	2^{20} / System Frequency
1	10	2^{22} / System Frequency
1	11	2^{24} / System Frequency

BME - Bus Timeout Monitor Enable

- 0 = Disable the bus timeout monitor for external bus cycles
- 1 = Enable timeout monitor for external bus cycles

NOTE

The bus monitor cannot be disabled for internal bus cycles to internal peripherals.

BMT[1:0] - Bus Monitor Timing

These bits select the timeout period for the bus timeout monitor as shown in Table 8-7. After system reset, the bus monitor timing bits are set to the maximum timeout value.

Table 8-7. Bus Monitor Timeout Periods

BMT[1:0]	BUS MONITOR TIMEOUT PERIOD
00	1024 system clocks
01	512 system clocks
10	256 system clocks
11	128 system clocks

8.3.2.8 SOFTWARE WATCHDOG INTERRUPT VECTOR REGISTER (SWIVR). The SWIVR contains the 8-bit interrupt vector that the SIM returns during an interrupt acknowledge cycle in response to a SWT-generated interrupt.

The SWIVR is an 8-bit write-only register, which is set to the uninitialized vector \$0F at system reset.

Software Watchdog Interrupt Vector Register(SWIVR) Address MBAR + \$42

7	6	5	4	3	2	1	0
SWIV7	SWIV6	SWIV5	SWIV4	SWIV3	SWIV2	SWIV1	SWIV0
RESET:							
0	0	0	0	1	1	1	1

8.3.2.9 SOFTWARE WATCHDOG SERVICE REGISTER (SWSR). The SWSR is the location to which the SWT servicing sequence is written. To prevent an SWT timeout, you should write a \$55 followed by a \$AA to this register. Although both writes must occur in the order listed prior to the SWT timeout, any number of instructions or accesses to the SWSR can be executed between the two writes. This allows interrupts and exceptions to occur, if necessary, between the two writes.

The SWSR is an 8-bit write-only register. At system reset, the contents of SWSR are uninitialized.

Software Watchdog Service Register(SWSR) Address MBAR + \$43

7	6	5	4	3	2	1	0
SWSR7	SWSR6	SWSR5	SWSR4	SWSR3	SWSR2	SWSR1	SWSR0
RESET:							
-	-	-	-	-	-	-	-

Write Only

8.3.2.10 PIN ASSIGNMENT REGISTER (PAR). The PAR lets you select certain signal pin assignments. You can select between address, chip selects and write enables, data and parallel port signals, processor status (PST) and parallel port signals, and UART request-to-send and reset out.

The PAR is an 8-bit read-write register. At system reset, all bits are cleared.

PAR9 - Pin Assignment Bit 9

Pin Assignment register (PAR) Address MBAR + \$CA

15	14	13	12	11	10	9	8	7	6	5	4	3	2	1	0
PAR15	PAR14	PAR13	PAR12	PAR11	PAR10	PAR9	PAR8	PAR7	PAR6	PAR5	PAR4	PAR3	PAR2	PAR1	PAR0
RESET:															
0	0	0	0	0	0	0	0	0	0	0	0	0	0	0	0

R/W

This bit lets you select the signal input/output on the $\overline{\text{TOUT}}[0]/\overline{\text{DREQ}}[1]$ pin as follows:

- 0 = Output Timer 0 output ($\overline{\text{TOUT}}[0]$) signal on $\overline{\text{TOUT}}[0]/\overline{\text{DREQ}}[1]$ pin
- 1 = Input DMA channel 1 request on $\overline{\text{TOUT}}[0]/\overline{\text{DREQ}}[1]$ pin

PAR8 - Pin Assignment Bit 8

This bit lets you select the signal output on the $\overline{TIN}[0]/\overline{DREQ}[0]$ pin as follows:

- 0 = Input Timer 0 ($\overline{TIN}[0]$) signal on $\overline{TIN}[0]/\overline{DREQ}[0]$ pin
- 1 = Input DMA channel 0 request on $\overline{TIN}[0]/\overline{DREQ}[0]$ pin

PAR7 - Pin Assignment Bit 7

This bit lets you select the signal output on the $RTS[2]/\overline{RSTO}$ pin as follows:

- 0 = Output reset out (\overline{RSTO}) signal on $RTS[2]/\overline{RSTO}$ pin
- 1 = Output UART 2 request to send signal on $RTS[2]/\overline{RSTO}$ pin

PAR6 - Pin Assignment Bit 6

This bit lets you select how the external interrupt inputs are used by the MCF5206e as follows:

- 0 = Set $\overline{IRQ7}/\overline{IPL2}$, $\overline{IRQ4}/\overline{IPL1}$ and $\overline{IRQ1}/\overline{IPL0}$ to be used as individual interrupt inputs at level 7, 4 and 1, respectively.
- 1 = Set $\overline{IRQ7}/\overline{IPL2}$, $\overline{IRQ4}/\overline{IPL1}$ and $\overline{IRQ1}/\overline{IPL0}$ to be used as encoded interrupt priority level inputs

PAR5 - Pin Assignment Bit 5

This bit lets you select the signals output on the pins $PP[7:4]/PST[3:0]$ as follows:

- 0 = Output general purpose I/O signals PP7 - PP4 on $PP[7:4]/PST[3:0]$ pins
- 1 = Output background debug mode signals PST3 - PST0 on $PP[7:4]/PST[3:0]$ pins

PAR4 - Pin Assignment Bit 4

This bit lets you select the signals output on the pins $PP[3:0]/DDATA[3:0]$ as follows:

- 0 = Output Parallel Port output signals PP3 - PP0 on $PP[3:0]/DDATA[3:0]$ pins
- 1 = Output background debug mode signals DDATA3 - DDATA0 on $PP[3:0]/DDATA[3:0]$ pins

PAR3 - PAR0 - Pin Assignment Bits 3 - 0

These bits let you select the signal output on the pins $\overline{CS}[7:4]/A[27:24]/\overline{WE}[3:0]$. You can select the signals as shown in Table 8-8.

Table 8-8. PAR3 - PAR0 Pin Assignment

PAR[3:0]	A27/CS7/WE0	A26/CS6/WE1	A25/CS5/WE2	A24/CS4/WE3
0000	WE0	WE1	WE2	WE3
0001	WE0	WE1	CS5	CS4
0010	WE0	WE1	CS5	A24
0011	WE0	WE1	A25	A24
0100	WE0	CS6	CS5	CS4
0101	WE0	CS6	CS5	A24

8.9 BUS ARBITRATION CONTROL

8.9.1 Bus Master Arbitration Control (MARB)

The MARB determines the internal master bus arbitration. It selects the highest master, and can also disable arbitration.

set to the top priority if a higher priority master constantly demands the bus. Possible solutions to this problem are:

- Changing the ARBCTRL setting at regular intervals to allow for different masters to share the highest priority.
- Using lower priority masters for “non-essential” tasks which can be completed in the idle bus cycles of the top priority master.
- Writing code which executes from the instruction cache or single-cycle on-chip SRAM and therefore provides more idle bus cycles for other masters to use.

The internal arbiter has been specifically designed to recognize bus cycles that hit in the cache and are prematurely terminated. These killed cycles often happen sequentially as the processor executes a line from the cache. When the arbiter sees an instruction fetch that has been killed, it will lower the priority of the ColdFire core for the next bus cycle. This allows the DMA channels to utilize bus bandwidth the ColdFire core would otherwise be wasting. The DMA channels should always use the largest transfer of which they are capable, to transfer the most data in any opportunity. When using interrupts, caution should be exercised if the ColdFire core is not the highest priority and not immediately able to answer the interrupt. This could result in a spurious interrupt condition. Use of the Bus Timeout Monitor is always recommended for use with non-core masters, since it can provide a method of escaping a master requesting bad transfers.

The NOARB bit simply disables arbiter operation. Setting the NOARB bit causes the MCF5206e to behave similarly to the MCF5206, however DMA transfers are not now allowed, since the DMA channels cannot arbitrate for the bus. This functionality has been provided primarily for customers upgrading older MCF5206 designs where the DMA would not be used.

NOARB - Arbiter operation disable.

0 = Arbitration enabled

1 = Arbitration disabled (MCF5206 mode)

The ARBCTRL bit determines the highest priority on the internal master bus. These options are shown in table 8-9:

Table 8-9. Arbitration Control Encodings (ARBCTRL)

ARBCTRL	HIGHEST PRIORITY BUS MASTER	LOWEST PRIORITY BUS MASTER
0	ColdFire Core	Internal DMA Channels
1	Internal DMA Channels	ColdFire Core

ARBCTRL - Set the arbitration priority for the internal master bus.

0 = Arbitration order = ColdFire Core, Internal DMA channels

1 = Arbitration order = Internal DMA channels, ColdFire Core

SECTION 9 CHIP SELECT MODULE

9.1 INTRODUCTION

The chip select module provides user-programmable control of the eight chip select and four write enable outputs. This subsection describes the operation and programming model of the chip select registers, including the chip select address, mask, and control registers.

9.1.1 Features

The following list summarizes the key chip select features:

- Eight programmable chip selects
- Address masking for memory block sizes from 64 K- to 2 GBytes
- Programmable wait states and port sizes
- Programmable address setup
- Programmable address hold for read and write
- Programmable wait states and port sizes for default memory
- External master access to chip selects

9.2 CHIP SELECT MODULE I/O

9.2.1 Control Signals

The chip select controller outputs eight chip select and four write enables. The chip select controller activates these signals for ColdFire core-initiated transfers as well as during external master-initiated transfers. The chip select controller can also output transfer acknowledge (\overline{TA}) during external master transfers.

9.2.1.1 CHIP SELECT ($\overline{CS}[7:0]$). These active-low output signals provide control for peripherals and memory. $\overline{CS}[7:4]$ are multiplexed with upper address signals ($A[27:24]$) and the write enable ($\overline{WE}[3:0]$) signals. $\overline{CS}[0]$ provides the special function of global chip select to let you relocate boot ROM at any defined address space. $\overline{CS}[1]$ provides the special function of asserting during CPU space accesses including interrupt acknowledge cycles.

9.2.1.2 WRITE ENABLE ($\overline{WE}[3:0]$). These active-low output signals provide control for peripherals and memory during write transfers. $\overline{WE}[3:0]$ are multiplexed with upper address and upper chip selects.

During a write transfers, these outputs indicate which bytes within a long-word transfer are being selected and which bytes of the data bus are used for the transfer. $\overline{WE}[0]$ controls D[31:24], $\overline{WE}[1]$ controls D[23:16], $\overline{WE}[2]$ controls D[15:8] and $\overline{WE}[3]$ controls D[7:0]. These signals provide byte data select signals that are decoded from the SIZx, A[1:0] signals in addition to the programmed port size and burst capability of the memory being accessed, as shown in Table 9-1.

Table 9-1. Data Bus Byte Write Enables

TRANSFER SIZE	PORT SIZE	BURST	SIZ[1]	SIZ[0]	A1	A0	$\overline{WE}0$	$\overline{WE}1$	$\overline{WE}2$	$\overline{WE}3$
							D[31:24]	D[23:16]	D[15:8]	D[7:0]
BYTE	8-BIT	0/1	0	1	0	0	0	1	1	1
					0	1	0	1	1	1
					1	0	0	1	1	1
					1	1	0	1	1	1
	16-BIT	0/1	0	1	0	0	0	1	1	1
					0	1	1	0	1	1
					1	0	0	1	1	1
					1	1	1	0	1	1
	32-BIT	0/1	0	1	0	0	0	1	1	1
					0	1	1	0	1	1
					1	0	1	1	0	1
					1	1	1	1	1	0
WORD	8-BIT	0	0	1	0	0	0	1	1	1
					0	1	0	1	1	1
					1	0	0	1	1	1
					1	1	0	1	1	1
	8-BIT	1	1	0	0	0	0	1	1	1
					0	1	0	1	1	1
					1	0	0	1	1	1
					1	1	0	1	1	1
	16-BIT	0/1	1	0	0	0	0	0	1	1
					1	0	0	0	1	1
					0	0	0	0	1	1
					1	0	0	0	1	1
32-BIT	0/1	1	0	0	0	0	0	1	1	
				1	0	1	1	0	0	

Freescale Semiconductor, Inc.

Table 9-1. Data Bus Byte Write Enables

TRANSFER SIZE	PORT SIZE	BURST	SIZ[1]	SIZ[0]	A1	A0	$\overline{\text{WE0}}$	$\overline{\text{WE1}}$	$\overline{\text{WE2}}$	$\overline{\text{WE3}}$
							D[31:24]	D[23:16]	D[15:8]	D[7:0]
LONGWORD	8-BIT	0	0	1	0	0	0	1	1	1
					0	1	0	1	1	1
					1	0	0	1	1	1
					1	1	0	1	1	1
	1	0	0	0	0	0	1	1	1	
				0	1	0	1	1	1	
				1	0	0	1	1	1	
				1	1	0	1	1	1	
	0	1	0	0	0	0	0	1	1	
				1	0	0	0	1	1	
				0	0	0	0	1	1	
				1	0	0	0	1	1	
0/1	0	0	0	0	0	0	0	0		
			0	0	0	0	0	0		
LINE	8-BIT	0	0	1	0	0	0	1	1	1
					0	1	0	1	1	1
					1	0	0	1	1	1
					1	1	0	1	1	1
		1	1	1	0	0	0	1	1	1
					0	1	0	1	1	1
					1	0	0	1	1	1
					1	1	0	1	1	1
	0	1	0	0	0	0	0	1	1	
				1	0	0	0	1	1	
				0	0	0	0	1	1	
				1	0	0	0	1	1	
	0	0	0	0	0	0	0	0	0	
				1	1	1	0	0	0	
	1	1	1	0	0	0	0	0	0	
				0	0	0	0	0	0	

9.2.1.3 ADDRESS BUS. The address bus includes 24 dedicated address signals, A[23:0], and supports as many as four additional address signals, A[27:24]. The chip select or default memory address appears only on the pins configured to be address signals. The maximum size of a memory bank is limited by the number of address signals available (see Table 9-2).

For transfers initiated by the ColdFire core, the MCF5206e outputs the address and increments the lower bits during burst transfers, allowing the address bus to be directly

Table 9-2. Maximum Memory Bank Sizes

AVAILABLE ADDRESS SIGNALS	MAXIMUM CS BANK SIZE
A[23:0]	16 Mbyte
A[24:0]	32 Mbyte
A[25:0]	64 Mbyte
A[26:0]	128 Mbyte
A[27:0]	256 Mbyte

connected to external memory. The MCF5206e does not output the address during external master initiated transfers to chip select memory.

9.2.1.4 DATA BUS. You can configure the chip select and default memory spaces to be 8-, 16-, or 32-bits wide. A 32-bit port must reside on data bus bits D[31:0], a 16-bit port must reside on data bus bits D[31:16], and an 8-bit port must reside on data bus bits D[31:24]. This requirement ensures that the MCF5206e correctly transfers valid data to 8-, 16-, and 32-bit ports. Figure 9-1 illustrates the connection of the data bus to 8-, 16-, and 32-bit ports.

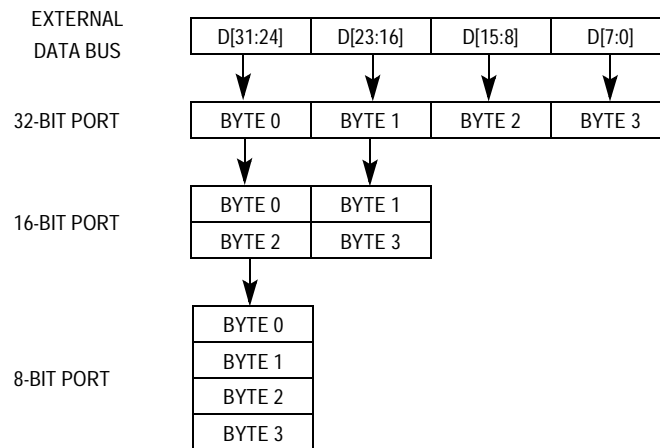

Figure 9-1. MCF5206e Interface to Various Port Sizes

9.2.1.5 TRANSFER ACKNOWLEDGE (\overline{TA}). Transfer acknowledge is a bidirectional signal that indicates the current data transfer has been successfully completed. You can program \overline{TA} to be output after a programmed number of wait states during external master-initiated transfers that hit in chip select or default memory address space. \overline{TA} is an input during ColdFire core-initiated transfers that hit in chip select or default memory address space.

9.3 CHIP SELECT OPERATION

The chip select controller provides a glueless interface to certain types of external memory including PROM and peripherals and external control signals for an easy

interface to SRAM, EPROM, EEPROM and peripherals. Each of the eight chip select outputs has an address register, mask register and control register providing individual 16-bit address decode, 16-bit address masking, port size and burst capability indication, wait-state generation, automatic acknowledge generation as well as address setup and address hold features.

Chip selects 0 and 1 provide special functionality. Chip select 0 is a “global” chip select after reset that provides relocatable boot ROM capability. Chip select 1 can be programmed to assert during CPU space accesses including interrupt acknowledge cycles.

The chip select controller also provides a control register for “default memory,” which is all of the memory space that is not defined by a chip select or DRAM bank. The default memory control register lets you program features of the default bus transfer including port size, burst capability, and wait-state generation.

9.3.1 Chip Select Bank Definition

The general-purpose chip selects are controlled by the Chip Select Address Register (CSAR), Chip Select Mask Register (CSMR), and the Chip Select Control Register (CSCR). There is one CSAR, one CSMR, and one CSCR for each chip select signal generated.

9.3.1.1 BASE ADDRESS AND ADDRESS MASKING. The transfer address generated by the ColdFire core or by an external master is compared to the unmasked bits of the base address programmed for each chip select bank in the Chip Select Address Registers (CSAR0 - CSAR7). The masked address bits are controlled by the value programmed in the BAM field in the Chip Select Mask Registers (CSMR0 - CSMR7).

The masking of address bits defines the address space of the chip select bank. Address bits that are masked are not used in the comparison with the transfer address. The base address field (BA31-BA16) in the CSARs and the base address mask field (BAM31-BAM16) in the CSMRs correspond to transfer address bits 31-16. Clearing all bits in the BAM field makes the address space 64 kbyte. For the address space of a chip select bank to be contiguous, address bits should be masked (BAM bits set to a 1) in ascending order starting with A[16].

NOTE

The MCF5206e compares the address for the current bus transfer with the address and mask bits in the Chip Select Address Registers (CSARs), DRAM Controller Address Registers (DCARs), the Chip Select Mask Registers (CSMRs), and DRAM Controller Mask Register (DCMRs),

looking for a match.

The priority is listed in Table 9-3 (from highest priority to lowest priority):

Table 9-3. Chip Select, DRAM and Default Memory Address Decoding Priority

Highest priority	Chip Select 0
	Chip Select 1
	Chip Select 2
	Chip Select 3
	Chip Select 4
	Chip Select 5
	Chip Select 6
	Chip Select 7
	DRAM bank 0
	DRAM bank 1
	default memory
	Lowest priority

The MCF5206e compares the address and mask in chip select 0 - 7 (chip select 0 is compared first), then the address and mask in DRAM 0 - 1. If the address does not match in either or these, the MCF5206e uses the control bits in the Default Memory Control Register (DMCR) to control the bus transfer. If the Default Memory Control Register (DMCR) control bits are used, no chip select or DRAM control signals are asserted during the transfer.

9.3.1.2 ACCESS PERMISSIONS. Chip select accesses can be restricted based on transfer direction and attributes. Each chip select can be enabled for read and/or write transfers using the WR and RD bits in the CSCRs. Each chip select can have supervisor data, supervisor code, user data, user code, and only chip select 1 can have CPU space (including interrupt acknowledge) transfers masked from their address space using the SD, SC, UD, UC, and C/I bits in the CSMRs. The transfer address must match, the transfer direction must be enabled, and transfer attributes must be unmasked for a chip select to assert.

9.3.1.3 CONTROL FEATURES. The chip select control registers and the default memory control register are used to program timing and assertion features of the chip selects. The chip select control register provides the following programmable control features:

- Port size (8-, 16- or 32-bit)
- Number of internal wait states (0 - 15)
- Enable assertion of internal transfer acknowledge
- Enable assertion of transfer acknowledge for external master transfers
- Enable burst transfers

- Address setup
- Address hold
- Enable read and/or write transfers

9.3.1.3.1 8-, 16-, and 32-Bit Port Sizing. The general-purpose chip selects support static bus sizing. You can program the size of the port controlled by a chip select. Defined 8 bit ports are connected to D[31:24]; defined 16-bit ports are connected to D[31:16]; and defined 32 bit ports are connected to D[31:0]. The port size is specified by the PS bits in the CSCR.

9.3.1.3.2 Termination. The general-purpose chip selects support three methods of termination: internal termination, synchronous termination, and asynchronous termination. You can program the number of wait states required for each chip select and the default memory individually. You can also enable internal termination for MCF5206e-initiated transfers for each chip select and default memory individually.

Transfer acknowledge (\overline{TA}) can synchronously terminate a transfer. If the MCF5206e initiates a bus transfer and internal termination is enabled (but \overline{TA} is asserted before the specified number of wait states have been inserted), the transfer terminates on the CLK cycle where \overline{TA} is asserted.

NOTE

If an external master initiates a bus transfer and internal termination is enabled, \overline{TA} should not be driven by an external device. The MCF5206e drives \overline{TA} throughout the external master access.

Asynchronous transfer acknowledge (\overline{ATA}) can asynchronously terminate a chip select or default memory transfer. If the MCF5206e initiates a bus transfer and internal termination is enabled but \overline{ATA} is asserted before the specified number of wait states have been inserted, the transfer terminates on the CLK cycle where the internal asynchronous transfer acknowledge is asserted. If an external master initiates a bus transfer and internal termination is enabled, \overline{ATA} can be driven by an external device to terminate the transfer before the specified number of wait states has been inserted. In this case, the transfer terminates when the internal asynchronous transfer acknowledge is asserted.

9.3.1.3.3 Bursting Control. The general-purpose chip selects support burst and non-bursting peripherals and memory. If an external chip select device cannot be accessed using burst transfers, you can program the burst-enable bit in the appropriate chip select Control Register (CSCR) or in the Default Memory Control Register (DMCR) to a 0. If the burst-enable bit is set to 1, burst transfers are generated anytime the requested operand size is greater than the programmed chip select or default memory port size. If the burst enable bit is set to 0, nonburst transfers are always generated for the particular chip select or default memory access. Figure 9-5, Figure 9-6, and Figure 9-7 illustrate burst transfers with various settings of address setup, address hold, and 0 wait states.

9.3.1.3.4 Address Setup and Hold Control. The timing of the assertion and negation of the general-purpose chip selects and write enables can be programmed on a chip select basis. You can program each chip select to assert when the clock transfer start (\overline{TS}) is asserted or assert the CLK cycle after transfer start (\overline{TS}) is asserted. For burst transfers, you can select if the chip select remains valid while the burst address is incremented. You can also program the address, attribute, and data (if the transfer is a write) to remain driven and valid for an additional CLK cycle after the transfer is terminated. Figures 9-2, 9-3, and 9-4 illustrate three transfers with various settings.

9.3.2 Global Chip Select Operation

$\overline{CS}[0]$ is the global (boot) chip select and as such, allows address decoding for boot ROM before system initialization occurs. Its operation differs from the other external chip select outputs following a system reset. After system reset, $\overline{CS}[0]$ is asserted for all accesses except for CPU space accesses (including MOVEC transfers and interrupt acknowledge cycles), and internal peripheral accesses. This capability allows the boot ROM to be located at any address in the external address space. $\overline{CS}[0]$ operates in this manner until CSMR0 is written.

The port size and automatic acknowledge functions of $\overline{CS}[0]$ are determined by the logic level on pins $\overline{IRQ1}$, $\overline{IRQ4}$, and $\overline{IRQ7}$ sampled on the last rising edge of CLK that \overline{RSTI} is asserted (see **Bus Operations Section 6.11 Reset Operation**).

At system reset, $\overline{CS}[0]$ allows read and write transfers with address setup, read and write address-hold enabled, and bursting disabled. Writes to CSCR0 do not deactivate the global chip select function; therefore, the number of wait states, read and write enable, address setup, read and write address hold enable, and burst-enable may be changed.

The global chip select functionality is disabled on the first write to CSMR0 after reset. You should set up the appropriate chip select, DRAM, and default memory control registers before writing a 1 to CSMR0. Once CSMR0 has been written, the global chip select functionality can be reactivated only by reset.

9.3.3 General Chip Select Operation

The MCF5206e uses the address bus (A[27:0]) to specify the location for a data transfer and the data bus (D[31:0]) to transfer the data. Chip selects are asserted during bus transfers where the address, transfer direction and type are not masked for the particular chip select. Write enables are asserted on write transfers and indicate the valid byte lanes for the transfer. Write enables are always asserted on the CLK cycle after the chip select is asserted.

Chip select and write enables can be asserted during burst and burst inhibited transfers. The assertion and negation timing of the chip selects are controlled by the address setup, read address hold, and write address hold bits in the chip select control registers.

9.3.3.1 NONBURST TRANSFER WITH NO ADDRESS SETUP AND NO ADDRESS HOLD. Figure 9-2 illustrates a supervisor data longword write transfer to a 32-bit port. In this case, address setup and write address hold features are disabled.

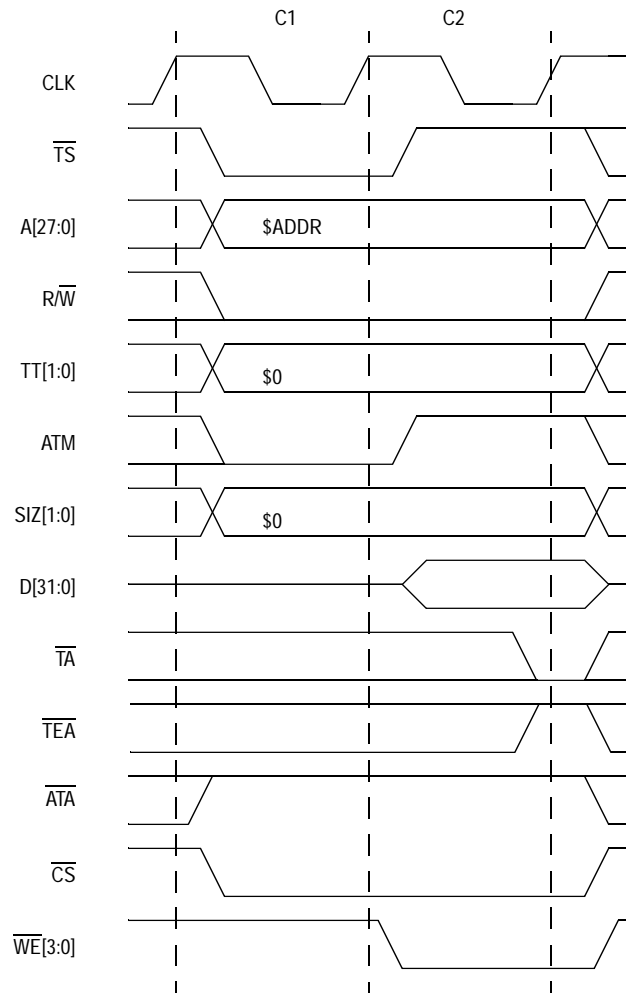

Figure 9-2. Longword Write Transfer from a 32-Bit Port (No Wait State, No Address Setup, No Address Hold)

Clock 1 (C1)

The write cycle starts in C1. During C1, the MCF5206e places valid values on the address bus (A[27:0]) and transfer control signals. The transfer type (TT[1:0]) signals identify the specific access type and access type and mode (ATM) is driven low to identify the transfer as data. The read/write (R/W) signal is driven low for a write cycle, and the size signals (SIZ[1:0]) are driven low to indicate a longword transfer. The MCF5206e asserts transfer start (TS) to indicate the beginning of a bus cycle and asserts the appropriate chip select (CS) for the address being accessed.

Clock 2 (C2)

During C2, the MCF5206e negates transfer start (\overline{TS}), drives access type and mode (ATM) high to identify the transfer as supervisor and drives data onto D[31:0]. If the selected device(s) is ready to latch the data, it latches D[31:0] and asserts the transfer acknowledge (\overline{TA}). At the end of C2, the MCF5206e samples the level of \overline{TA} . If \overline{TA} is asserted, the transfer of the longword is complete, and the MCF5206e negates \overline{CS} and $\overline{WE}[3:0]$ after the next rising edge of CLK. If \overline{TA} is negated, the MCF5206e continues to sample \overline{TA} and inserts wait states instead of terminating the transfer. The MCF5206e continues to sample \overline{TA} on successive rising edge of CLK until it is asserted. If the bus monitor timer is enabled and \overline{TA} is not asserted before the programmed bus monitor time is reached, the cycle is terminated with an internal bus error.

9.3.3.2 NONBURST TRANSFER WITH ADDRESS SETUP. Figure 9-3 illustrates a word user data write transfer to a 16-bit port with address setup enabled..

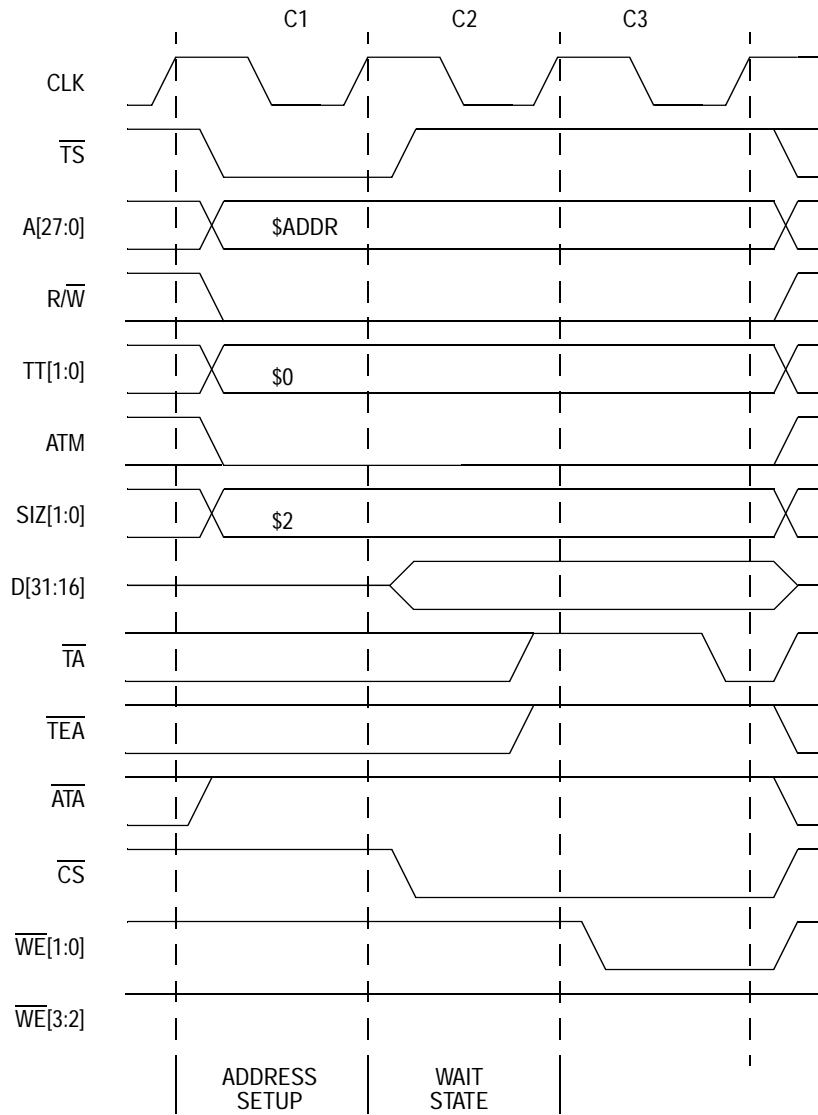

Figure 9-3. Word Write Transfer to a 16-Bit Port (One Wait State, Address Setup, No Address Hold)

Clock 1 (C1)

The write cycle starts in C1. During C1, the MCF5206e places valid values on the address bus (A[27:0]) and transfer control signals. The transfer type (TT[1:0]) signals identify the specific access type and access type and mode (ATM) is driven low to identify the transfer as data. The read/write (R/W) signal is driven low for a write cycle, and the size signals (SIZ[1:0]) are driven to \$2 to indicate a word transfer. The MCF5206e asserts transfer start (\overline{TS}) to indicate the beginning of a bus cycle. The chip select (\overline{CS}) signal is driven high since the appropriate address setup bit in the chip select control register is set to 1.

Clock 2 (C2)

During C2, the MCF5206e negates transfer start (\overline{TS}), drives access type and mode (ATM) low to identify the transfer as user and drives data onto D[31:16] and asserts the appropriate chip select (\overline{CS}) signal. At the end of C2, the MCF5206e samples the level of TA. If TA was asserted the transfer of the word would be complete. Since \overline{TA} is negated, the MCF5206e continues to output the data and inserts a wait state instead of terminating the transfer.

Clock 3 (C3)

The MCF5206e asserts the write enable ($\overline{WE}[1:0]$) signals. If the selected device(s) is ready to latch the data, it latches D[31:0] and asserts the transfer acknowledge (TA). At the end of C3, the MCF5206e samples the level of \overline{TA} . If \overline{TA} is asserted, the transfer of the word is complete, and the MCF5206e negates \overline{CS} and $\overline{WE}[1:0]$ after the rising edge of CLK. If TA is negated, the MCF5206e continues to sample TA and inserts wait states instead of terminating the transfer. The MCF5206e continues to sample \overline{TA} on successive rising edge of CLK until it is asserted. If the bus monitor timer is enabled and \overline{TA} is not asserted before the programmed bus monitor time is reached, the cycle is terminated with an internal bus error.

NOTE

When address setup is enabled (ASET=1), write enables ($\overline{WE}[3:0]$) do not assert on zero wait state write transfers.

9.3.3.3 NONBURST TRANSFER WITH ADDRESS SETUP AND HOLD. Figure 9-4 illustrates a supervisor data byte write transfer to an 8-bit port with address setup and write address hold enabled.

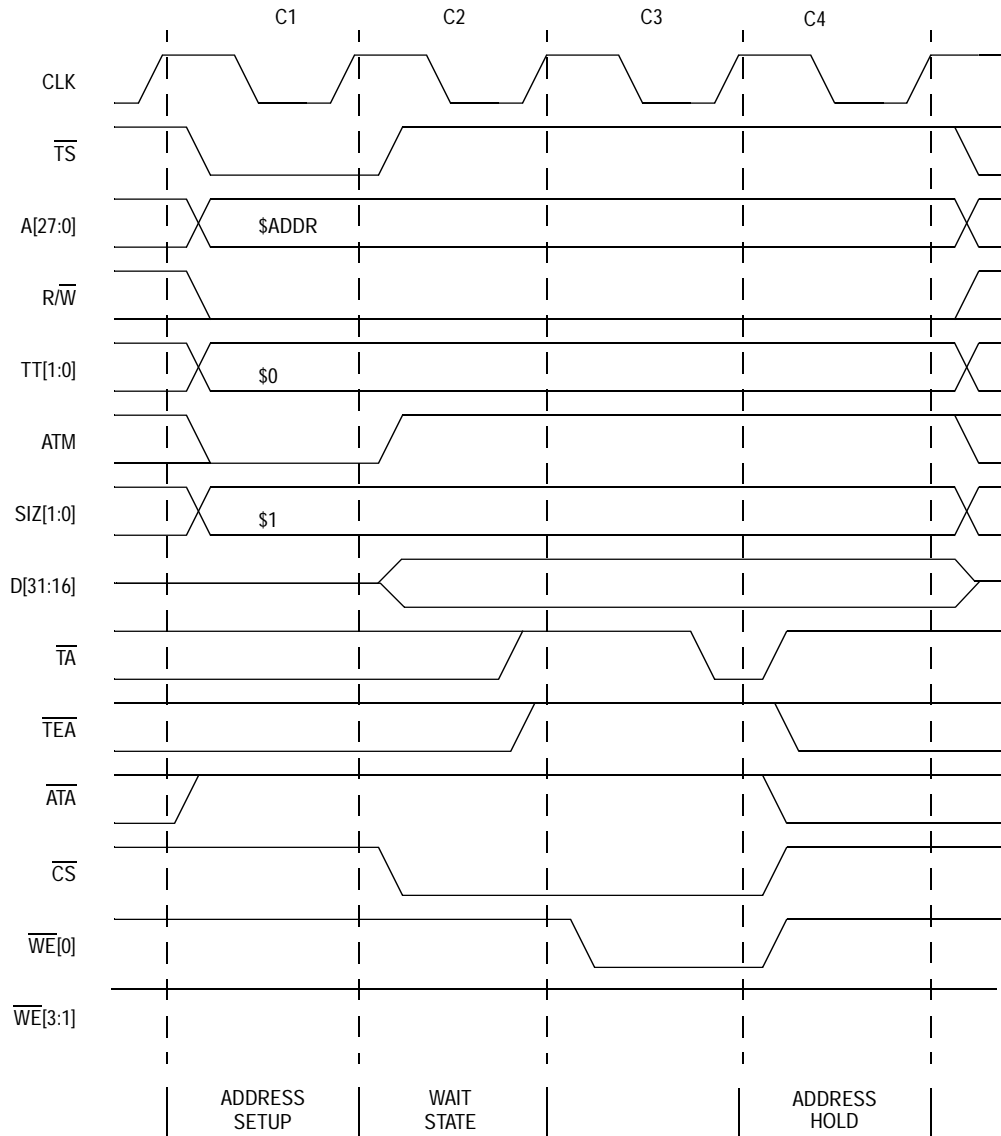

Figure 9-4. Byte Write Transfer from an 8-Bit Port (One Wait State, Address Setup, Address Hold)

Clock 1 (C1)

The write cycle starts in C1. During C1, the MCF5206e places valid values on the address bus (A[27:0]) and transfer control signals. The transfer type (TT[1:0]) signals identify the specific access type and access type and mode (ATM) is driven low to identify the transfer as data. The read/write (R/W) signal is driven low for a write cycle, and the size signals (SIZ[1:0]) are driven to \$1 to indicate a byte transfer. The MCF5206e asserts transfer start (TS) to indicate the beginning of a bus cycle. The chip select (CS) signal is driven high since the appropriate address setup bit in the chip select control register is set to 1.

Clock 2 (C2)

During C2, the MCF5206e negates transfer start (\overline{TS}), drives access type and mode (ATM) high to identify if the transfer as supervisor, drives data onto D[31:16] and asserts the appropriate chip select (\overline{CS}). At the end of C2, the MCF5206e samples the level of \overline{TA} . If \overline{TA} was asserted the transfer of the word would be complete. Since \overline{TA} is negated, the MCF5206e continues to output the data and inserts a wait state instead of terminating the transfer.

Clock 3 (C3)

The MCF5206e asserts the write enable ($\overline{WE}[1:0]$) signals. If the selected device(s) is ready to latch the data, it latches D[31:0] and asserts the transfer acknowledge (\overline{TA}). At the end of C3, the MCF5206e samples the level of \overline{TA} . If \overline{TA} is asserted, the transfer of the word is complete. If \overline{TA} is negated, the MCF5206e continues to sample \overline{TA} and inserts wait states instead of terminating the transfer. The MCF5206e continues to sample \overline{TA} on successive rising edge of CLK until it is asserted. If the bus monitor timer is enabled and \overline{TA} is not asserted before the programmed bus monitor time is reached, the cycle is terminated with an internal bus error.

Clock 4 (C4)

The MCF5206e negates the chip select (\overline{CS}) and write enable ($\overline{WE}[1:0]$) signals and continues to drive the address, data and attribute signals until after the next rising edge of CLK.

NOTE

When address setup is enabled (ASET=1), write enables ($\overline{WE}[3:0]$) do not assert on zero wait state write transfers.

9.3.3.4 BURST TRANSFER AND CHIP SELECTS. If the burst enable bit in the appropriate control register (Chip Select Control Register or Default Memory Control Register) is set to 1, and the operand size is larger than the port size of the memory being accessed, the MCF5206e performs word, longword and line transfers in burst mode. When burst mode is selected, the size of the transfer (indicated by SIZ[1:0]) reflects the size of the operand being read - not the size of the port being accessed (i.e. a line transfer is indicated by SIZ[1:0] = \$3 and a longword transfer is indicated by SIZ[1:0] = \$0, regardless of the size of the port or the number of transfers required to access the data).

The MCF5206e supports burst-inhibited transfers for memory devices that are unable to support bursting. For this type of bus cycle, the burst enable bit in the Chip Select Control Registers (CSCRs) or Default Memory Control Register (DMCR) must be cleared.

Figure 9-5 illustrates a supervisor code longword read transfer to a 16-bit port with address setup and address hold disabled.

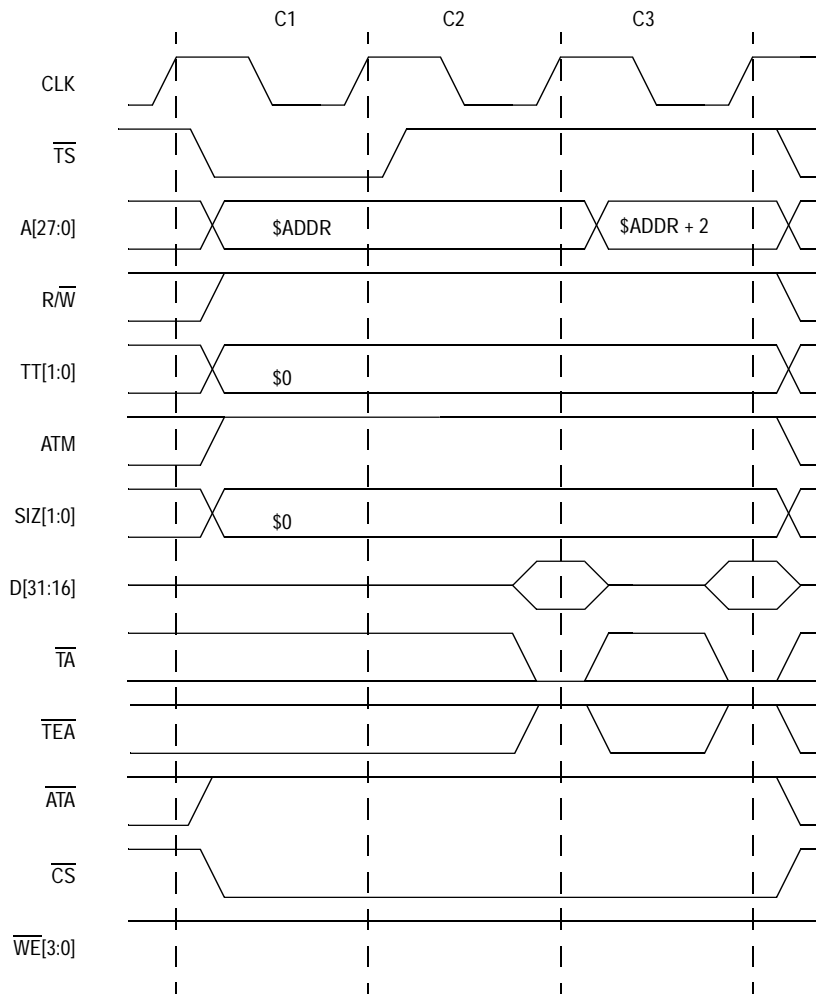

Figure 9-5. Longword Burst Read Transfer from a 16-Bit Port (No Wait States, No Address Setup, No Address Hold)

Clock 1 (C1)

The burst read cycle starts in C1. During C1, the MCF5206e places valid values on the address bus (A[27:0]) and transfer control signals. The transfer type (TT[1:0]) signals identify the specific access type and access type and mode (ATM) is driven high to identify the transfer as code. The read/write (R/W) and write enable ($\overline{WE}[3:0]$) signals are driven high for a read cycle, and the size signals (SIZ[1:0]) are driven low to indicate a longword transfer. The MCF5206e asserts transfer start (\overline{TS}) to indicate the beginning of a bus cycle and asserts the appropriate chip select (\overline{CS}) for the address being accessed.

Clock 2 (C2)

During C2, the MCF5206e negates transfer start (\overline{TS}), drives access type and mode (ATM) high to identify the transfer as supervisor. The selected device(s) places the addressed data onto D[31:16] and asserts the transfer acknowledge (\overline{TA}). At the end of

C2, the MCF5206e samples the level of \overline{TA} and if \overline{TA} is asserted, latches the current value of D[31:16]. If \overline{TA} is asserted, the transfer of the first word of the longword is complete. If \overline{TA} is negated, the MCF5206e continues to sample \overline{TA} and inserts wait states instead of terminating the transfer. The MCF5206e continues to sample \overline{TA} on successive rising edge of CLK until it is asserted. If the bus monitor timer is enabled and \overline{TA} is not asserted before the programmed bus monitor time is reached, the cycle is terminated with an internal bus error.

Clock 3 (C3)

During C3, the MCF5206e increments A[1:0] to indicate the second word in the longword transfer. The selected device(s) places the addressed data onto D[31:16] and asserts the transfer acknowledge (\overline{TA}). At the end of C3, the MCF5206e samples the level of \overline{TA} and if \overline{TA} is asserted, latches the current value of D[31:16]. If \overline{TA} is asserted, the transfer of the second word of the longword is complete and the transfer terminates and the chip select (\overline{CS}) is negated. If \overline{TA} is negated, the MCF5206e continues to sample \overline{TA} and inserts wait states instead of terminating the transfer. The MCF5206e continues to sample \overline{TA} on successive rising edge of CLK until it is asserted. If the bus monitor timer is enabled and \overline{TA} is not asserted before the programmed bus monitor time is reached, the cycle is terminated with an internal bus error.

9.3.3.5 BURST TRANSFER WITH ADDRESS SETUP. Figure 9-6 illustrates a longword user code read from a 16-bit port with address setup enabled and read address hold disabled.

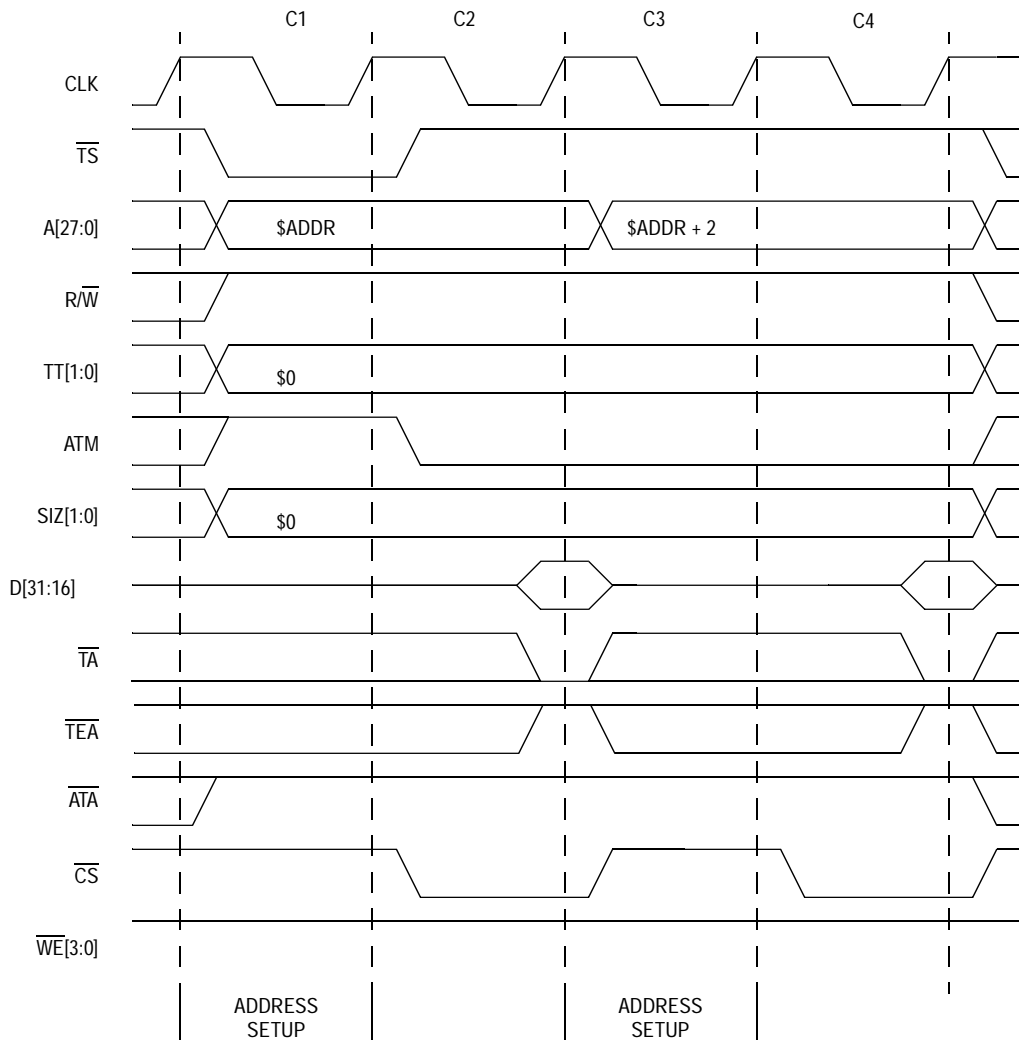

Figure 9-6. Longword Burst Read Transfer from a 16-Bit Port (No Wait States, Address Setup, No Address Hold)

Clock 1 (C1)

The burst read cycle starts in C1. During C1, the MCF5206e places valid values on the address bus (A[27:0]) and transfer control signals. The transfer type (TT[1:0]) signals identify the specific access type and access type and mode (ATM) is driven high to identify the transfer as reading code. The read/write (R/W) and write enable ($\overline{WE}[3:0]$) signals are driven high for a read cycle, and the size signals (SIZ[1:0]) are driven low to indicate a longword transfer. The MCF5206e asserts transfer start (TS) to indicate the beginning of a bus cycle. The chip select (\overline{CS}) signal is driven high since the appropriate address setup bit in the chip select control register is set to 1.

Clock 2 (C2)

During C2, the MCF5206e negates transfer start (\overline{TS}), drives access type and mode (ATM) low to identify if the transfer as user. The appropriate chip select (\overline{CS}) signal is asserted. The selected device(s) places the addressed data onto D[31:16] and asserts the transfer acknowledge (\overline{TA}). At the end of C2, the MCF5206e samples the level of \overline{TA} and if \overline{TA} is asserted, latches the current value of D[31:16]. If \overline{TA} is asserted, the transfer of the first word of the longword is complete and chip select (\overline{CS}) is negated after the next rising edge of CLK. If \overline{TA} is negated, the MCF5206e continues to sample \overline{TA} and inserts wait states instead of terminating the transfer. The MCF5206e continues to sample \overline{TA} on successive rising edge of CLK until it is asserted. If the bus monitor timer is enabled and \overline{TA} is not asserted before the programmed bus monitor time is reached, the cycle is terminated with an internal bus error.

Clock 3 (C3)

During C3, the MCF5206e increments A[1:0] to indicate the second word in the longword transfer. The chip select (\overline{CS}) signal is driven high since the appropriate address setup bit in the chip select control register is set to 1.

Clock 4 (C4)

The selected device(s) places the addressed data onto D[31:16] and asserts the transfer acknowledge (\overline{TA}). At the end of C4, the MCF5206e samples the level of \overline{TA} and if \overline{TA} is asserted, latches the current value of D[31:16]. If \overline{TA} is asserted, the transfer of the second word of the longword is complete and the transfer terminates and the chip select (\overline{CS}) is negated. If \overline{TA} is negated, the MCF5206e continues to sample \overline{TA} and inserts wait states instead of terminating the transfer. The MCF5206e continues to sample \overline{TA} on successive rising edge of CLK until it is asserted. If the bus monitor timer is enabled and \overline{TA} is not asserted before the programmed bus monitor time is reached, the cycle is terminated with an internal bus error.

NOTE

When address setup is enabled (ASET=1), write enables (WE[3:0]) do not assert on zero wait state write transfers.

9.3.3.6 BURST TRANSFER WITH ADDRESS SETUP AND HOLD. Figure 9-7 illustrates a supervisor data word read transfer from an 8-bit port with address setup and read address hold enabled.

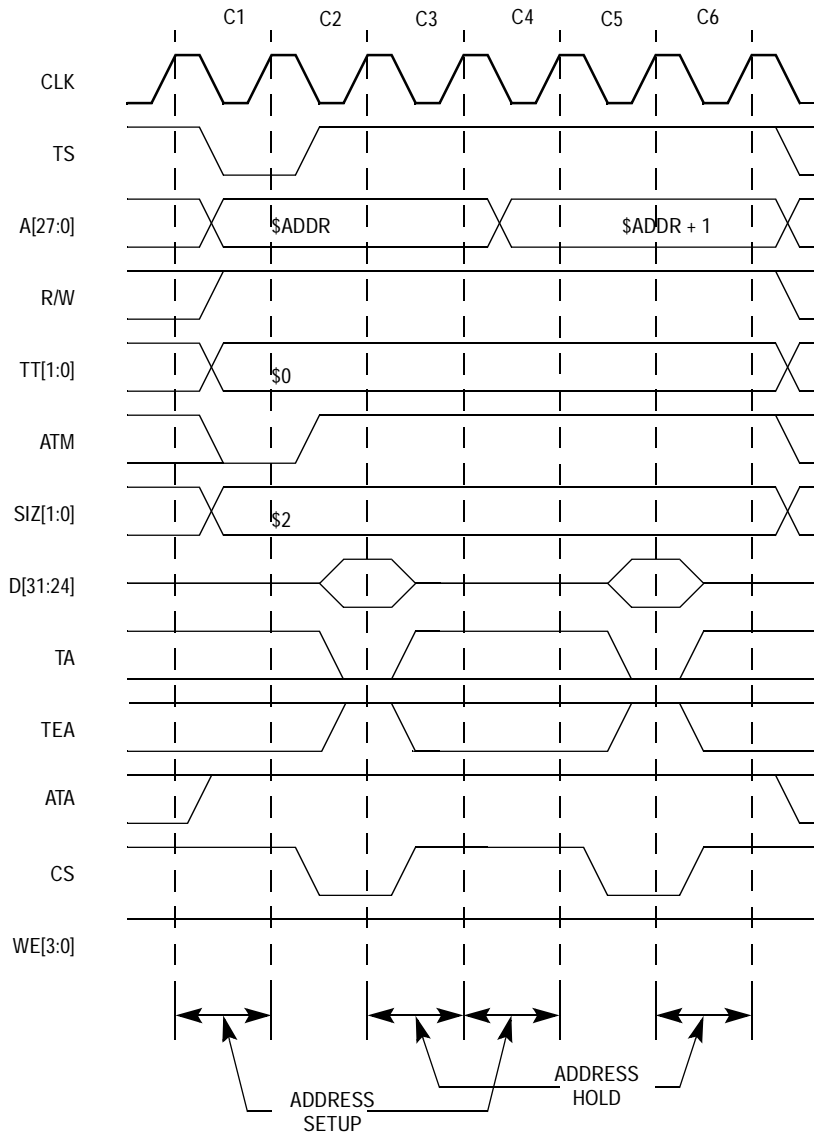

Figure 9-7. Word Burst Read Transfer from an 8-Bit Port (No Wait States, Address Setup, Address Hold)

Clock 1 (C1)

The burst read cycle starts in C1. During C1, the MCF5206e places valid values on the address bus (A[27:0]) and transfer control signals. The transfer type (TT[1:0]) signals identify the specific access type and access type and mode (ATM) is driven low to identify the transfer as reading data. The read/write (R/W) and write enable (WE[3:0]) signals are driven high for a read cycle, and the size signals (SIZ[1:0]) are driven to \$2 to indicate a word transfer. The MCF5206e asserts transfer start (TS) to indicate the beginning of a bus cycle. The chip select (CS) signal is driven high since the appropriate address setup bit in the chip select control register is set to 1.

Clock 2 (C2)

During C2, the MCF5206e negates transfer start (\overline{TS}), drives access type and mode (ATM) high to identify the transfer as supervisor. The appropriate chip select (\overline{CS}) signal is asserted. The selected device(s) places the addressed data onto D[31:24] and asserts the transfer acknowledge (\overline{TA}). At the end of C2, the MCF5206e samples the level of \overline{TA} and if \overline{TA} is asserted, latches the current value of D[31:24]. If \overline{TA} is asserted, the transfer of the first byte of the word is complete and chip select (\overline{CS}) is negated after the next rising edge of CLK. If \overline{TA} is negated, the MCF5206e continues to sample \overline{TA} and inserts wait states instead of terminating the transfer. The MCF5206e continues to sample \overline{TA} on successive rising edge of CLK until it is asserted. If the bus monitor timer is enabled and \overline{TA} is not asserted before the programmed bus monitor time is reached, the cycle is terminated with an internal bus error.

Clock 3 (C3)

The MCF5206e continues to drive address and bus attributes since the read address hold bit in the appropriate chip select control register is set to 1.

Clock 4(C4)

During C3, the MCF5206e increments A[0] to indicate the second byte in the word transfer. The chip select (\overline{CS}) signal is driven high since the appropriate address setup bit in the chip select control register is set to 1.

Clock 5(C5)

The selected device(s) places the addressed data onto D[31:24] and asserts the transfer acknowledge (\overline{TA}). At the end of C5, the MCF5206e samples the level of \overline{TA} and if \overline{TA} is asserted, latches the current value of D[31:24]. If \overline{TA} is asserted, the transfer of the second word of the longword is complete and the transfer terminates and the chip select (\overline{CS}) is negated. If \overline{TA} is negated, the MCF5206e continues to sample \overline{TA} and inserts wait states instead of terminating the transfer. The MCF5206e continues to sample \overline{TA} on successive rising edge of CLK until it is asserted. If the bus monitor timer is enabled and \overline{TA} is not asserted before the programmed bus monitor time is reached, the cycle is terminated with an internal bus error.

Clock 6 (C6)

The MCF5206e continues to drive address and bus attributes since the read address hold bit in the appropriate chip select control register is set to 1.

NOTE

When address setup is enabled (ASET=1), write enables (WE[3:0]) do not assert on zero wait state write transfers.

9.3.4 External Master Chip Select Operation

The MCF5206e can monitor bus transfers by other bus masters and assert chip select and transfer termination signals during these transfers. Assertion of chip select and termination signals occurs when the bus is granted to another bus master and \overline{TS} is asserted by the external master as an input to the MCF5206e. The MCF5206e registers the value of A[27:0], $\overline{R/W}$ and SIZ[1:0] on the rising edge of CLK in which \overline{TS} is asserted.

NOTE

If the pins A[27:24]/ \overline{CS} [7:4]/ \overline{WE} [0:3] are not assigned to output address signals, a value of \$0 is assigned internally to these signals. Also, TT[1:0] and ATM are not examined during external master transfers. The mask bits: SC, SD, UC, UD, and C/I in the Chip Select Mask Registers (CSMR) are not used during external master transfers.

The MCF5206e examines the address, direction and size of the transfer and on the next rising edge of CLK, begins assertion of the proper sequence of memory control signals. If the transfer is decoded to be a chip select address and the chip select is enabled for the direction of the transfer (read and/or write enabled), the appropriate chip select and write enables are asserted. If the chip select is enabled for external master automatic acknowledge, \overline{TA} is driven and asserted at the appropriate time. The MCF5206e does not drive address during external bus master accesses that are decoded as chip select or default memory transfers. The external master must provide the correct address to the external memory at the appropriate time.

If the address of the transfer is neither a chip select or a DRAM address, the SIM reads the Default Memory Control Register (DMCR). If the external master automatic acknowledge (EMAA) bit in the Default Memory Control Register (DMCR) is set, the MCF5206e drives transfer acknowledge (\overline{TA}) as an output and asserts transfer acknowledge after the number of clocks programmed in the wait state bits (WS) in the Default Memory Control Register (DMCR).

9.3.4.1 EXTERNAL MASTER NONBURST TRANSFER. The general-purpose chip selects support burst and nonbursting peripherals and memory for external master accesses. If an external chip select device can not be accessed using burst transfers, you can program the burst-enable bit in the appropriate Chip Select Control Register (CSCR) or in the Default Memory Control Register (DMCR) to a 0. If the burst-enable bit is set to 1, and the external master initiates a transfer where the transfer size is greater than the programmed port size, the MCF5206e asserts the chip select control signals for a burst transfer. If the burst enable bit is set to 0, the external master should never initiate a transfer with the size specified as larger than the programmed port size. Figure 9-8 illustrates a longword read transfer initiated by an external master to a 32-bit port.

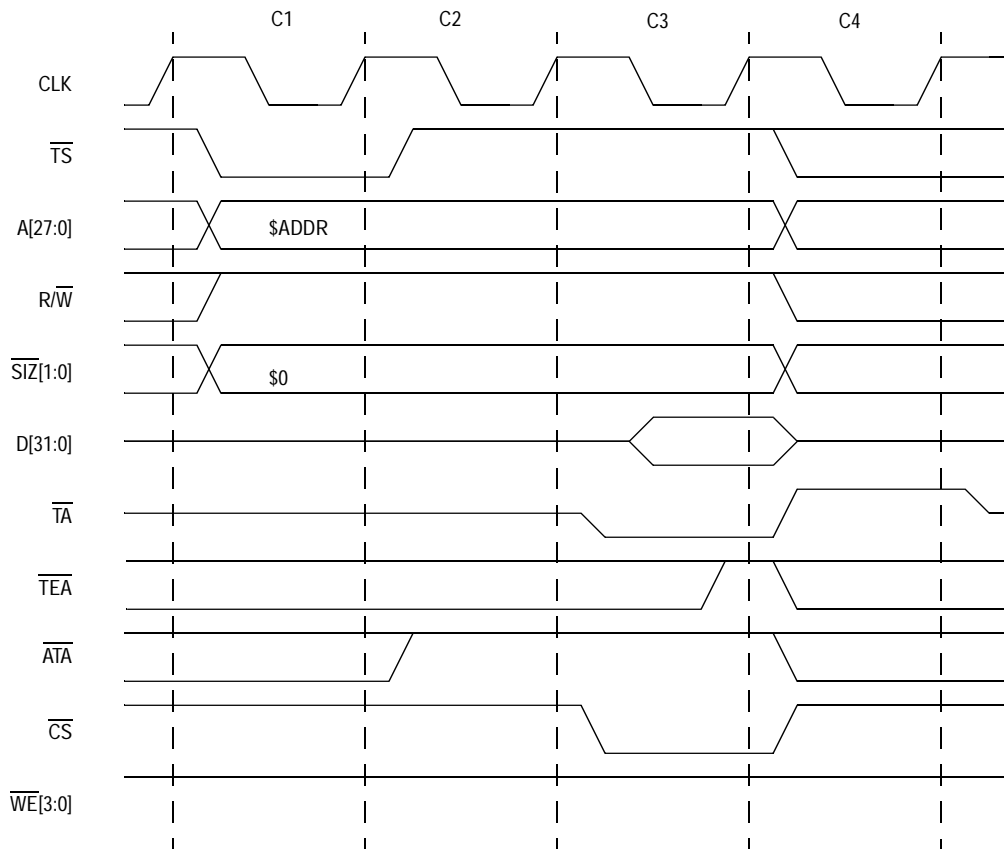

Figure 9-8. External Master Longword Read Transfer from a 32-Bit Port (No Wait State, No Address Setup, No Address Hold)

Clock 1 (C1)

The write cycle starts in C1. During C1, the external master places valid values on the address bus (A[27:0]) and transfer control signals. The MCF5206e registers the external master address, read/write and size signals.

Clock 2 (C2)

During C2, the external master negates transfer start (\overline{TS}). The MCF5206e compares the external master address to the internal chip select addresses and enables the appropriate chip select for assertion.

Clock 3 (C3)

The MCF5206e asserts the appropriate chip select and since the EMAA bit in the appropriate Chip Select Control Register (CSCR) is set to one, asserts transfer acknowledge (TA). The selected device drive data onto D[31:0]. At the end of C3, the external master samples the level of TA. If TA is asserted, the transfer of the longword is

complete. If \overline{TA} is negated, the external master continues to sample \overline{TA} and inserts wait states instead of terminating the transfer.

Clock 4 (C4)

At the start of clock 4, the MCF5206e negates \overline{CS} and \overline{TA} , completing the external master transfer. After the next rising edge of CLK, the MCF5206e three states \overline{TA} . The external master can assert \overline{TS} starting another transfer.

9.3.4.2 EXTERNAL MASTER BURST TRANSFER. The timing of the assertion and negation of the general-purpose chip selects and write enables during external master accesses can be programmed on a chip select basis. The address setup and hold features of the chip selects are not used during nonburst external master accesses. The address setup and hold features can insert CLK cycles where the chip select is negated, during burst cycles. During external master read transfers, the MCF5206e drives the activated chip select signal negated for one CLK cycle for each of the address setup and read address hold bits that are set to 1. During external master write transfers, the MCF5206e drives the activated chip select signal negated for one CLK cycle for each of the address setup and write address hold bits that are set to 1. Figure 9-9 illustrates a bursting longword read transfer from a 16-bit port with no address setup and no address hold.

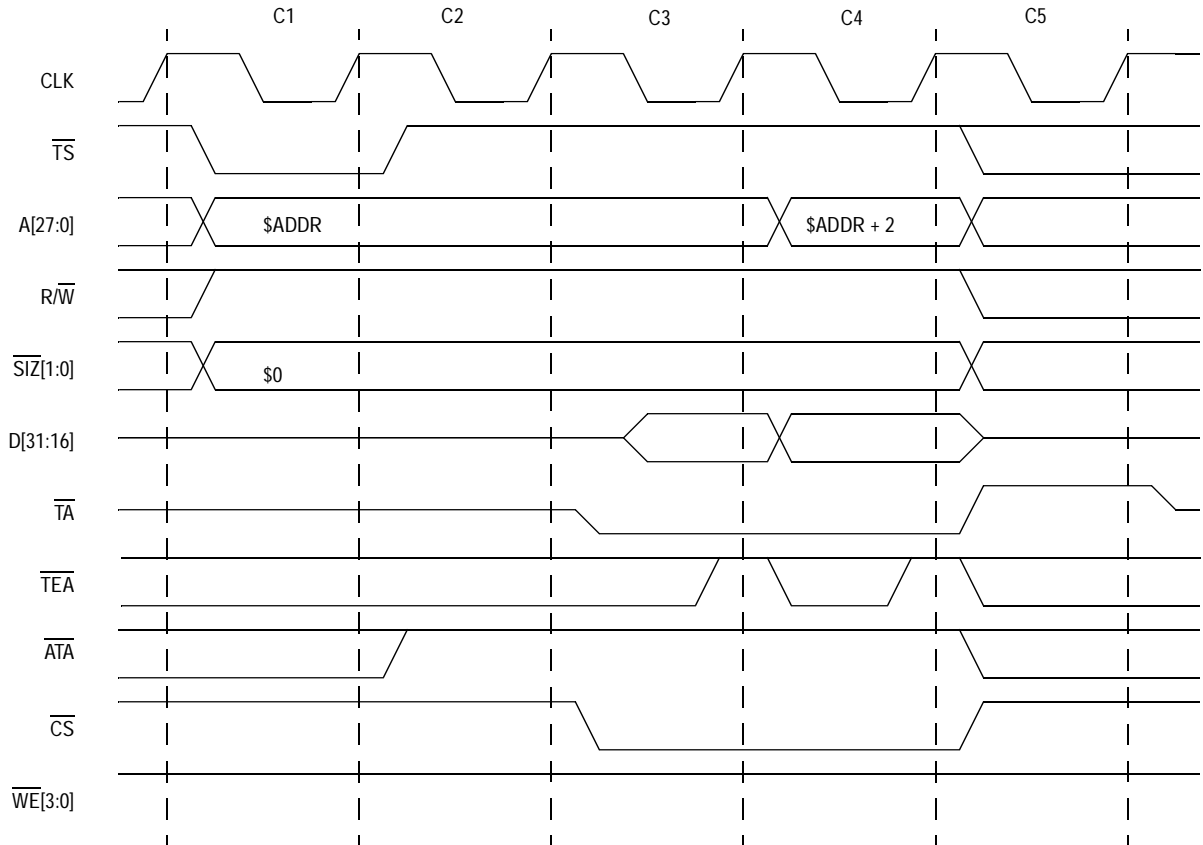

Figure 9-9. External Master Longword Read Transfer from a 16-bit Port (No Wait State, No Address Setup, No Address Hold)

Clock 1 (C1)

The read cycle starts in C1. During C1, the external master places valid values on the address bus (A[27:0]) and transfer control signals. At the end of C1, the MCF5206e registers the external master address, read/write and size signals.

Clock 2 (C2)

During C2, the external master negates transfer start (\overline{TS}). The MCF5206e compares the external master address to the internal chip select addresses and enables the appropriate chip select and transfer acknowledge (\overline{TA}) for assertion.

Clock 3 (C3)

The MCF5206e asserts the appropriate chip select and since the EMAA bit in the appropriate Chip Select Control Register (CSCR) is set to one and wait states are set to zero, asserts transfer acknowledge (\overline{TA}). The selected device drives data onto D[31:16]. At the end of C3, the external master samples the level of \overline{TA} . If \overline{TA} is asserted, the

transfer of the first word of the longword is complete. If \overline{TA} is negated, the external master continues to sample \overline{TA} and inserts wait states instead of terminating the transfer.

Clock 4 (C4)

At the start of clock 4, the external master increments the address to indicate the second word of the longword transfer. The MCF5206e continues to assert \overline{CS} and \overline{TA} and the selected slave outputs the data indicated by the new address on D[31:16]. At the end of clock 4, the external master samples the level of \overline{TA} . If \overline{TA} is asserted, the transfer of the second word of the longword is complete. If \overline{TA} is negated, the external master continues to sample \overline{TA} .

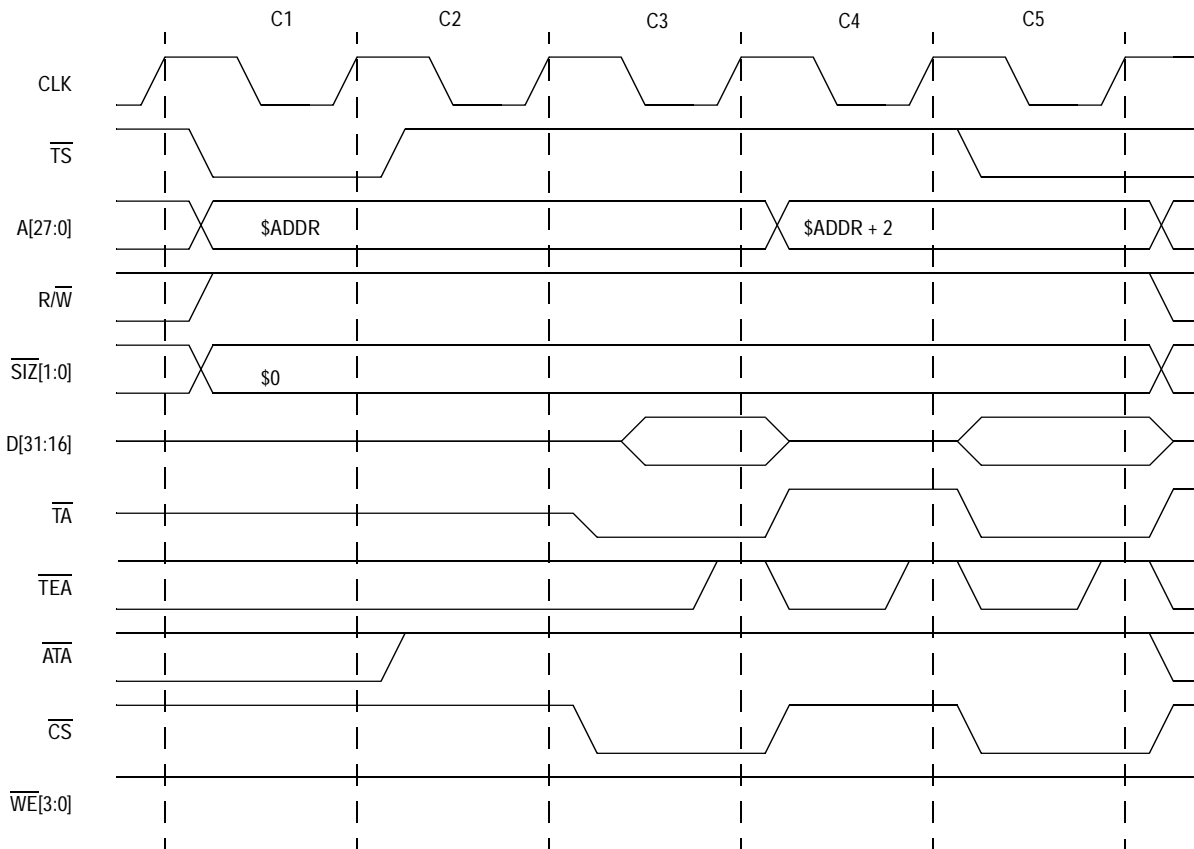

Figure 9-10. External Master Longword Read Transfer from a 16-Bit Port (No Wait State, With Address Setup Or Read Address Hold)

Clock 1 (C1)

The read cycle starts in C1. During C1, the external master places valid values on the address bus (A[27:0]) and transfer control signals. At the end of C1, the MCF5206e registers the external master address, read/write and size signals.

Clock 2 (C2)

During C2, the external master negates transfer start (\overline{TS}). The MCF5206e compares the external master address to the internal chip select addresses and enables the appropriate chip select and transfer acknowledge (\overline{TA}) for assertion.

Clock 3 (C3)

The MCF5206e asserts the appropriate chip select and since the EMAA bit in the appropriate Chip Select Control Register (CSCR) is set to one and wait states are set to zero, asserts transfer acknowledge (\overline{TA}). The selected device drives data onto D[31:16]. At the end of C3, the external master samples the level of \overline{TA} . If \overline{TA} is asserted, the

transfer of the first word of the longword is complete. If \overline{TA} is negated, the external master continues to sample \overline{TA} and inserts wait states instead of terminating the transfer.

Clock 4 (C4)

At the start of clock 4, the external master increments the address to indicate the second word of the longword transfer. The MCF5206e negates \overline{CS} and \overline{TA} .

Clock 5 (C5)

At the start of clock 5, the MCF5206e asserts \overline{CS} and \overline{TA} . The selected slave outputs the data indicated by the address on D[31:16]. At the end of clock 4, the external master samples the level of \overline{TA} . If \overline{TA} is asserted, the transfer of the second word of the longword is complete. If \overline{TA} is negated, the external master continues to sample \overline{TA} and inserts wait states instead of terminating the transfer.

After the next rising edge of CLK, the MCF5206e negates \overline{CS} and \overline{TA} , completing the external master transfer. After the next rising edge of CLK, the MCF5206e three states \overline{TA} . The external master can assert \overline{TS} starting another transfer.

NOTE

Write enables ($\overline{WE}[3:0]$) do not assert on zero wait state external master write transfers.

9.4 PROGRAMMING MODEL

9.4.1 Chip Select Registers Memory Map

Table 9-4 shows the memory map of all the chip select module registers. The internal registers in the chip select module are memory-mapped registers offset from the MBAR address pointer.

The following lists several keynotes regarding the programming model table:

- Addresses not assigned to a register and undefined register bits are reserved for future expansion. Write accesses to these reserved address spaces and reserved register bits have no effect; read accesses return zeros.
- The reset value column indicates the register initial value at reset. Certain registers may be uninitialized at reset, i.e., they may contain random values after reset.

Table 9-4. Memory Map of Chip Select Registers

ADDRESS	NAME	WIDTH	DESCRIPTION	RESET VALUE	ACCESS
MBAR + \$64	CSAR0	16	Chip Select Address Register - Bank 0	0000	R/W
MBAR + \$68	CSMR0	32	Chip Select Mask Register - Bank 0	00000000	R/W
MBAR + \$6E	CSCR0	16	Chip Select Control Register - Bank 0	3C1F, 3C5F, 3C9F, 3CDF, 3D1F, 3D5F, 3D9F, or 3DDF AA set by IRQ7 at reset PS1 set by IRQ4 at reset PS0 set by IRQ1 at reset	R/W
MBAR + \$70	CSAR1	16	Chip Select Address Register - Bank 1	uninitialized	R/W
MBAR + \$74	CSMR1	32	Chip Select Mask Register - Bank 1	uninitialized	R/W
MBAR + \$7A	CSCR1	16	Chip Select Control Register - Bank 1	uninitialized (except BRST=ASET=WRAH=RDAH=WR=R D=0)	R/W
MBAR + \$7C	CSAR2	16	Chip Select Address Register - Bank 2	uninitialized	R/W
MBAR + \$80	CSMR2	32	Chip Select Mask Register - Bank 2	uninitialized	R/W
MBAR + \$86	CSCR2	16	Chip Select Control Register - Bank 2	uninitialized (except BRST=ASET=WRAH=RDAH=WR=R D=0)	R/W
MBAR + \$88	CSAR3	16	Chip Select Address Register - Bank 3	uninitialized	R/W
MBAR + \$8C	CSMR3	32	Chip Select Mask Register - Bank 3	uninitialized	R/W
MBAR + \$92	CSCR3	16	Chip Select Control Register - Bank 3	uninitialized (except BRST=ASET=WRAH=RDAH=WR=R D=0)	R/W
MBAR + \$94	CSAR4	16	Chip Select Address Register - Bank 4	uninitialized	R/W
MBAR + \$98	CSMR4	32	Chip Select Mask Register - Bank 4	uninitialized	R/W
MBAR + \$9E	CSCR4	16	Chip Select Control Register - Bank 4	uninitialized (except BRST=ASET=WRAH=RDAH=WR=R D=0)	R/W
MBAR + \$A0	CSAR5	16	Chip Select Address Register - Bank 5	uninitialized	R/W
MBAR + \$A4	CSMR5	32	Chip Select Mask Register - Bank 5	uninitialized	R/W
MBAR + \$AA	CSCR5	16	Chip Select Control Register - Bank 5	uninitialized (except BRST=ASET=WRAH=RDAH=WR=R D=0)	R/W
MBAR + \$AC	CSAR6	16	Chip Select Address Register - Bank 6	uninitialized	R/W
MBAR + \$B0	CSMR6	32	Chip Select Mask Register - Bank 6	uninitialized	R/W

Table 9-4. Memory Map of Chip Select Registers (Continued)

ADDRESS	NAME	WIDTH	DESCRIPTION	RESET VALUE	ACCESS
MBAR + \$B6	CSCR6	16	Chip Select Control Register - Bank 6	uninitialized (except BRST=ASET=WR=RD=0)	R/W
MBAR + \$B8	CSAR7	16	Chip Select Address Register - Bank 7	uninitialized	R/W
MBAR + \$BC	CSMR7	32	Chip Select Mask Register - Bank 7	uninitialized	R/W
MBAR + \$C2	CSCR7	16	Chip Select Control Register - Bank 7	uninitialized (except BRST=ASET=WR=RD=0)	R/W
MBAR + \$C6	DMCR	16	Default Memory Control Register	0000	R/W

9.4.2 Chip Select Controller Registers

9.4.2.1 CHIP SELECT ADDRESS REGISTER (CSAR0 - CSAR7). Each CSAR determines the base address of the corresponding chip select pin.

Each CSAR is a 16-bit read/write register. CSAR0 is initialized to \$0000 at reset and CSAR1-CSAR7 are unaffected (uninitialized) by reset.

Chip Select Address Register(CSAR0) MBAR + 064

15 14 13 12 11 10 9 8 7 6 5 4 3 2 1 0

BA31	BA30	BA29	BA28	BA27	BA26	BA25	BA24	BA23	BA22	BA21	BA20	BA19	BA18	BA17	BA16
------	------	------	------	------	------	------	------	------	------	------	------	------	------	------	------

RESET: 0 0 0 0 0 0 0 0 0 0 0 0 0 0 0 0

Chip Select Address Register (CSAR1 - CSAR7)

15 14 13 12 11 10 9 8 7 6 5 4 3 2 1 0

BA31	BA30	BA29	BA28	BA27	BA26	BA25	BA24	BA23	BA22	BA21	BA20	BA19	BA18	BA17	BA16
------	------	------	------	------	------	------	------	------	------	------	------	------	------	------	------

RESET: - - - - - - - - - - - - - - - -

Freescale Semiconductor, Inc.

BA31-BA16 - Base Address

This field defines the base address location of memory dedicated to each chip select. These bits are compared to ColdFire core address bus bits 31-16 to determine if the chip select memory is being accessed. During external master accesses these bits are compared as shown in Table 9-5.

Table 9-5. BA Field Comparisons for External Master Transfers

BA BIT	COMPARED TO	CONDITIONS
BA31 - BA28	\$0	Always
BA27	\$0	A[27]/CS[7]/WE[0] does not output A[27]
	A[27]	A[27]/CS[7]/WE[0] outputs A[27]
BA26	\$0	A[26]/CS[6]/WE[1] does not output A[26]
	A[26]	A[26]/CS[6]/WE[1] outputs A[26]
BA25	\$0	A[25]/CS[5]/WE[2] does not output A[25]
	A[25]	A[25]/CS[5]/WE[2] outputs A[25]
BA24	\$0	A[24]/CS[4]/WE[3] does not output A[24]
	A[24]	A[24]/CS[4]/WE[3] outputs A[24]
BA23 - BA16	A[23:16]	Always

9.4.2.2 CHIP SELECT MASK REGISTER (CSMR0 - CSMR7). Each CSMR determines the address mask for each of the chip selects as well the definition of which types of accesses are allowed for these signals. Each CSMR is a 32-bit read/write control register. CSMR0 is initialized to \$00000000 by reset and CSMR7 - CSMR1 are unaffected (uninitialized) by reset. At reset, CS[0] is activated as the global chip select. A write to CSMR0 deactivates this function. CSMR1 has an additional control bit CPU that allows you to mask CPU space (including interrupt acknowledge) transfers.

Chip Select Mask Register(CSMR0) MBAR +\$68

31	30	29	28	27	26	25	24	23	22	21	20	19	18	17	16
BAM31	BAM30	BAM29	BAM28	BAM27	BAM26	BAM25	BAM24	BAM23	BAM22	BAM21	BAM20	BAM19	BAM18	BAM17	BAM16
RESET:	0	0	0	0	0	0	0	0	0	0	0	0	0	0	0
15	14	13	12	11	10	9	8	7	6	5	4	3	2	1	0
-	-	-	-	-	-	-	-	-	-	-	SC	SD	UC	UD	-
RESET:	0	0	0	0	0	0	0	0	0*	0	0	0	0	0	0

Freescale Semiconductor, Inc.

Chip Select Mask Register(CSMR1)

MBAR +\$74

31	30	29	28	27	26	25	24	23	22	21	20	19	18	17	16
BAM31	BAM30	BAM29	BAM28	BAM27	BAM26	BAM25	BAM24	BAM23	BAM22	BAM21	BAM20	BAM19	BAM18	BAM17	BAM16
RESET:															
-	-	-	-	-	-	-	-	-	-	-	-	-	-	-	-
15	14	13	12	11	10	9	8	7	6	5	4	3	2	1	0
-	-	-	-	-	-	-	-	-	-	C/I	SC	SD	UC	UD	-
RESET:															
0	0	0	0	0	0	0	0	0	0	0	-	-	-	-	0

Chip Select Mask Register(CSMR2 - CSMR7)

31	30	29	28	27	26	25	24	23	22	21	20	19	18	17	16
BAM31	BAM30	BAM29	BAM28	BAM27	BAM26	BAM25	BAM24	BAM23	BAM22	BAM21	BAM20	BAM19	BAM18	BAM17	BAM16
RESET:															
-	-	-	-	-	-	-	-	-	-	-	-	-	-	-	-
15	14	13	12	11	10	9	8	7	6	5	4	3	2	1	0
-	-	-	-	-	-	-	-	-	-	-	SC	SD	UC	UD	-
RESET:															
0	0	0	0	0	0	0	0	0	0	0	-	-	-	-	0

BAM [31:16] - Base Address Mask

This field defines the chip select block size through the use of address mask bits. Any bit set to 1 masks the corresponding base address register (CSAR) bit (the base address bit becomes a “don’t care” in the decode).

- 0 = Corresponding address bit is used in chip select address decode.
- 1 = Corresponding address bit is not used in chip select address decode.

C/I, SC, SD, UC, UD - CPU Space, Supervisor Code, Supervisor Data, User Code, User Data Transfer Mask

These fields allows specific types of transfers to be inhibited from accessing a chip select. If a transfer mask bit is cleared, a transfer of that type can access the corresponding chip select. If a transfer mask bit is set to 1, an transfer of that type can not access the corresponding chip select. The transfer mask bits are:

- C/I = CPU space and Interrupt Acknowledge Cycle mask ($\overline{CS}[1]$ only)
- SC = Supervisor Code mask
- SD = Supervisor Data mask
- UC = User Code mask
- UD = User Data mask

Freescale Semiconductor, Inc.

For each transfer mask bit:

- 0 = Do not mask this type of transfer for the chip select. A transfer of this type can occur for this chip select.
- 1 = Mask this type of transfer from the chip select. If this type of transfer is generated, this chip select activation is not activated.

NOTE

The C/I, SC, SD, UC, and UD bits are ignored during external master transfers. Therefore, an external master transfer can activate a chip select regardless of the transfer masks.

NOTE

In determining whether an external master transfer address hits in a chip select, the portion of the address bus that is unavailable externally is regarded as "0's." That is, the external master transfer address always has A[31:28] as 0's and those bits of A[27:24] that are not programmed to be external address bits as 0's. For a chip select to be activated by an external master, the address bits that are unavailable to the external master must either be set to 0 in the CSAR or be masked in the CSMR.

9.4.2.3 CHIP SELECT CONTROL REGISTER (CSCR0 - CSCR7). Each CSCR controls the acknowledge, external master support, port size, burst and activation features of each of the chip selects.

Each CSCR is a 16-bit read/write register. For CSCR1 - CSCR7, bits BRST, ASET, WRAH, RDAH, WR and RD are initialized to 0 by reset while, all other bits are unaffected (uninitialized) by reset. For CSCR0, bits BRST, and EMAA are initialized to 0 by reset, while bits WS3 - WS0, ASET, WRAH, RDAH, WR, and RD are initialized to 1 by reset. The determination of the reset value of bits AA, PS1, and PS0 in the CSCR0 register is controlled by the logic level at the last rising edge of CLK while reset is asserted, on pins IRQ7, IRQ4 and IRQ1, respectively. CS[0] is the global (boot) chip select and as such, allows address decoding for boot ROM before system initialization occurs. (see **Section 6: Bus Operations**). Table 9-6 shows how the logic levels on pins IRQ4 and IRQ1 correspond to the port sizes for CS[0]; Table 9-7 shows the logic levels of IRQ7 to enable or disable the automatic acknowledge function for CS[0].

Table 9-6. $\overline{\text{IRQ4}}$ and $\overline{\text{IRQ1}}$ Selection of $\overline{\text{CS[0]}}$ Port Size

IRQ4	IRQ1	BOOT $\overline{\text{CS[0]}}$ PORT SIZE
0	0	32-bit port
0	1	8-bit port
1	0	16-bit port
1	1	16-bit port

Table 9-7. $\overline{\text{IRQ7}}$ Selection of $\overline{\text{CS[0]}}$ Acknowledge Generation

IRQ7	BOOT $\overline{\text{CS[0]}}$ AA
0	Disabled
1	Enabled with 15 wait states

Chip Select Control Register(CSCR0) Address MBAR + \$6E
 15 14 13 12 11 10 9 8 7 6 5 4 3 2 1 0

-	-	WS3	WS2	WS1	WS0	BRST	AA	PS1	PS0	EMAA	ASET	WRAH	RDAH	WR	RD
---	---	-----	-----	-----	-----	------	----	-----	-----	------	------	------	------	----	----

RESET: 0 0 1 1 1 1 0 $\overline{\text{IRQ7}}$ $\overline{\text{IRQ4}}$ $\overline{\text{IRQ1}}$ 0 1 1 1 1 1

Chip Select Control Register(CSCR1-7)
 15 14 13 12 11 10 9 8 7 6 5 4 3 2 1 0

-	-	WS3	WS2	WS1	WS0	BRST	AA	PS1	PS0	EMAA	ASET	WRAH	RDAH	WR	RD
---	---	-----	-----	-----	-----	------	----	-----	-----	------	------	------	------	----	----

RESET: 0 0 - - - - 0 - - - - 0 0 0 0

WS[3:0] - Wait States

On accesses initiated by the ColdFire core when AA=1, this field defines the number of wait states inserted before an internal transfer acknowledge is generated. If $\overline{\text{TA}}$ is asserted by the external system before the indicated number of wait states are generated, the assertion of $\overline{\text{TA}}$ ends the cycle.

On accesses initiated by an external master when EMMA=1, this field defines the number of wait states inserted before $\overline{\text{TA}}$ is asserted.

BRST - Burst Enable

This field specifies the burst capability of the memory associated with each chip select.

- 0 = Break all transfers that are larger than the specified port size into individual non-burst transfers that are no larger than the specified port size (e.g. a longword transfer to an 8-bit port would be broken into four individual byte transfers)
- 1 = Allow burst transfers to the chip selected address space for all transfers that are larger than the specified port size (e.g. longword transfers to 8- and 16-bit ports, word transfers to 8-bit ports as well as line transfers to 8-, 16- and 32-bit ports)

AA - Auto Acknowledge Enable for ColdFire core initiated Transfers

This field controls the assertion of the internal transfer acknowledge during accesses initiated by the ColdFire core that hit in the corresponding chip select address space.

- 0 = Wait for external transfer acknowledge for accesses initiated by the ColdFire core
- 1 = Generate internal transfer acknowledge with the number of wait states specified by WS[3:0] for accesses initiated by the ColdFire core.

If AA=1 and \overline{TA} is asserted by the external system before the indicated number of wait states are generated, the external transfer acknowledge ends the transfer.

PS[1:0] - Port Size

This field specifies the width of the data associated with each chip select. It determines which byte lanes are driven with valid data during write cycles and which byte lanes are sampled for valid data during read cycles.

EMAA - External Master Automatic Acknowledge Enable

This field controls the driving and assertion of \overline{TA} during accesses initiated by an external master that hit in the corresponding chip select address space.

- 0 = Do not drive \overline{TA} as an output during accesses initiated by an external master and wait for external transfer acknowledge
- 1 = Drive \overline{TA} as an output for accesses initiated by an external master and insert the number of wait states specified by WS[3:0]

NOTE

Because \overline{TA} is an output when $\overline{EMAA} = 1$, \overline{TA} must not be driven by the external system. If \overline{TA} is asserted by the external system during external master transfer and $\overline{EMAA} = 1$, damage to the part could occur. **Refer to Section 6: Bus Operations** for more information on the assertion and driving of \overline{TA} during external master accesses.

ASET - Address Setup Enable

This field controls the assertion of chip select with respect to assertion of a valid address.

- 0 = Assert chip select on the rising edge of CLK that address is asserted. See Figure 9-11.
- 1 = Delay assertion of chip select for one CLK cycle after address is asserted. See Figure 9-12.

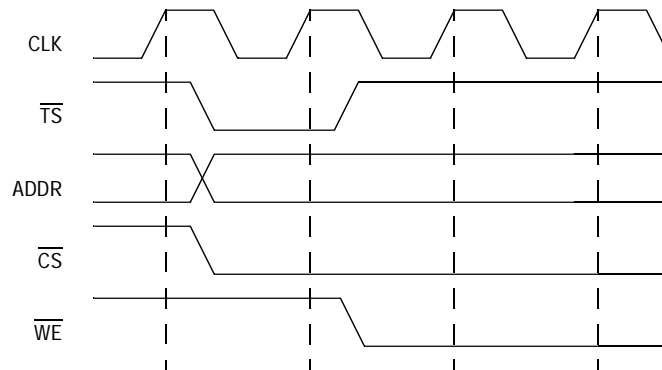

Figure 9-11. Chip select and Write Enable Assertion with ASET = 0 Timing

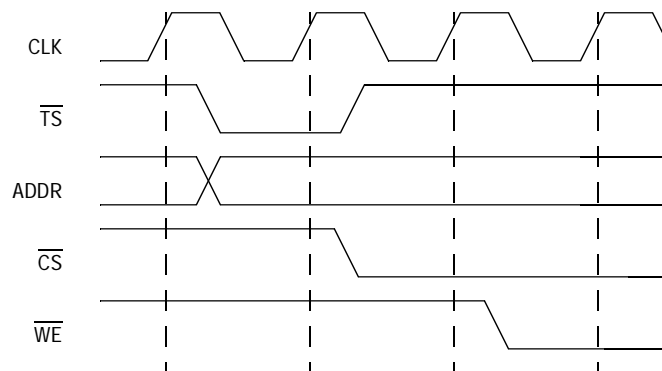

Figure 9-12. Chip select and Write Enable Assertion with ASET = 1 Timing

NOTE

\overline{WE} asserts one clock after the assertion of \overline{CS} . During write transfers, if ASET = 1, both \overline{CS} and \overline{WE} are delayed by one clock.

WRAH - Write Address Hold Enable

This field controls the address, data and attribute hold time after the termination (\overline{TA} , \overline{ATA} , \overline{TEA} , or internal transfer acknowledge) of a write cycle that hits in the chip select address space.

0 = Do not hold address, data, and attribute signals an extra cycle after \overline{CS} and \overline{WE} negate on writes. See Figure 9-13.

1 = Hold address, data, and attribute signals one cycle after \overline{CS} and \overline{WE} negate on writes. See Figure 9-14. Address Hold Timing with WRAH = 1.

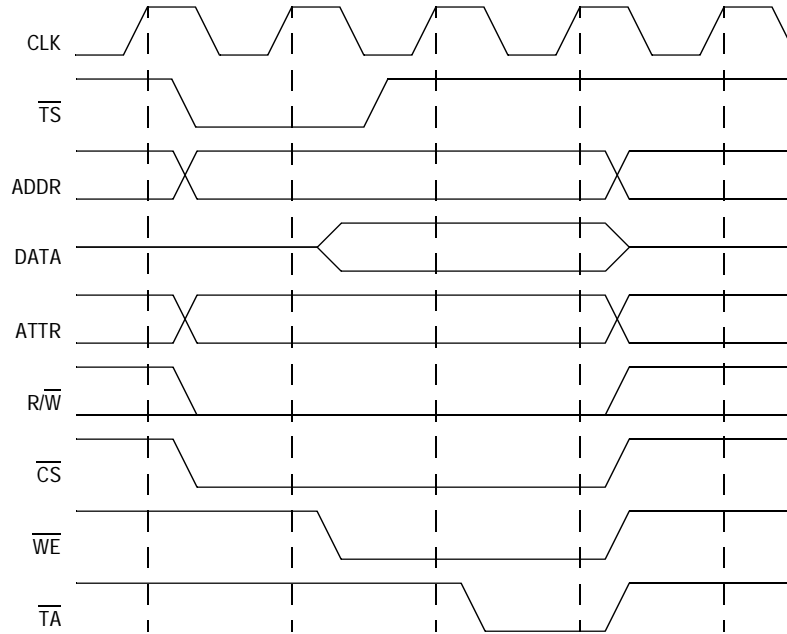

Figure 9-13. Address Hold Timing with WRAH = 0

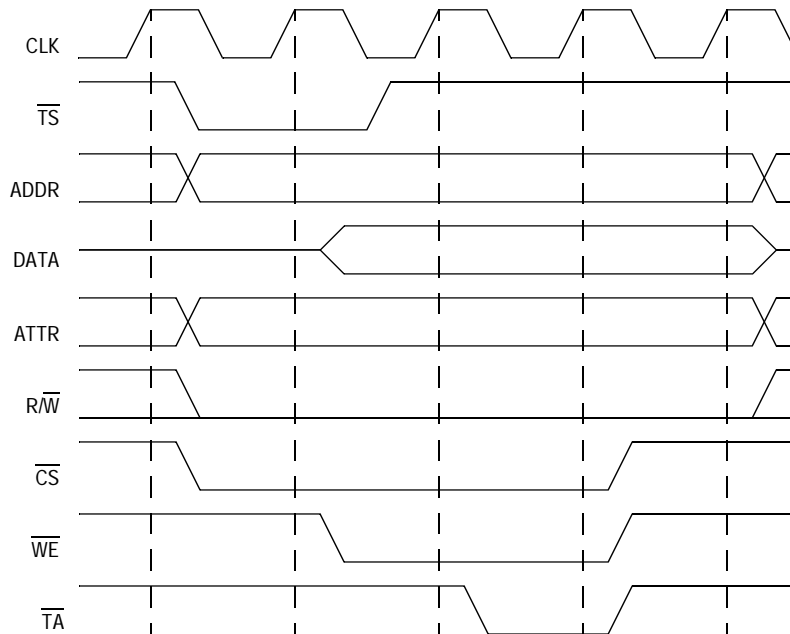

Figure 9-14. Address Hold Timing with WRAH = 1

RDAH - Read Address Hold Enable

This field controls the address and attribute hold time after the termination (\overline{TA} , \overline{ATA} , \overline{TEA} or internal transfer acknowledge) during a read cycle that hits in the chip select address space.

- 0 = Do not hold address and attributes an extra cycle after \overline{CS} negates on reads. See Figure 9-15.
- 1 = Hold address and attributes one cycle after \overline{CS} negates on reads. See Figure 9-16.

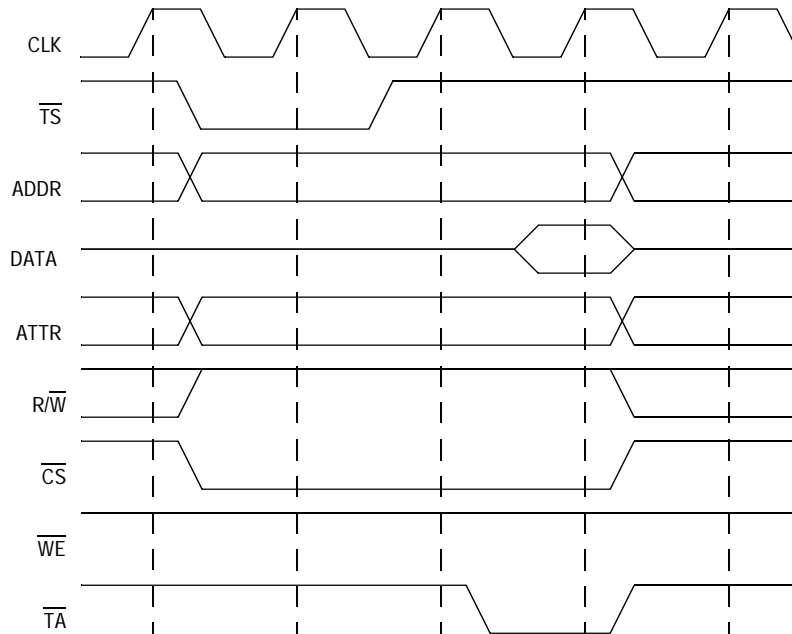

Figure 9-15. Address Hold Timing with RDAH = 0

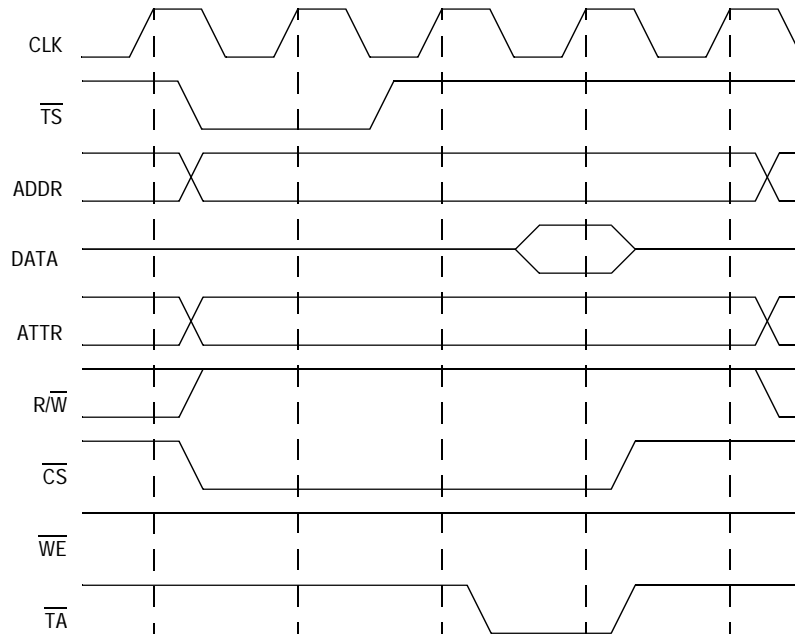

Figure 9-16. Address Hold Timing with RDAH = 1

WR - Write Enable

This field controls the assertion of chip select and write enable on write cycles.

0 = Disable this chip select during write transfers

1 = Chip select and write enables assert on writes that hit in the chip select address space

RD - Read Enable

This field controls the assertion of chip select on read cycles.

0 = Disable this chip select during read transfers

1 = Chip select asserts on read transfers that hit in the chip select address space

9.4.2.4 DEFAULT MEMORY CONTROL REGISTER (DMCR). All memory not associated with the eight chip select address spaces or two DRAM bank address spaces is considered default memory. The DMCR controls the acknowledge, port size, burst and address hold features for all default memory space.

The DMCR is a 16-bit read/write register. At system reset, the DMCR is initialized to \$0000.

Default Memory Control Register(DMCR)

Address MBAR + \$C6

15	14	13	12	11	10	9	8	7	6	5	4	3	2	1	0
-	-	WS3	WS2	WS1	WS0	BRST	AA	PS1	PS0	EMAA	-	WRAH	RDH	-	-
RESET:	0	0	0	0	0	0	0	0	0	0	0	0	0	0	0

WS[3:0] - Wait States

On accesses initiated by the ColdFire core when AA=1, this field defines the number of wait states inserted before an internal transfer acknowledge is generated. If \overline{TA} is asserted by the external system before the indicated number of wait states are generated, the external transfer acknowledge ends the cycle.

On accesses initiated by an external master when EMAA=1, this field defines the number of wait states to be inserted before \overline{TA} is asserted.

BRST - Burst Enable

This field specifies the burst capability of the default memory space.

- 0 = Break all transfers that are larger than the specified port size into individual non-burst transfers that are no larger than the specified port size (e.g. a longword transfer to an 8-bit port would be broken into four individual byte transfers)
- 1 = Allow burst transfers to the default memory space for all transfers that are larger than the specified port size (e.g. longword transfers to 8- and 16-bit ports, word transfers to 8-bit ports as well as line transfers to 8-, 16- and 32-bit ports)

AA - Auto-Acknowledge Enable for ColdFire Core-Initiated Transfers

This field controls the assertion of the internal transfer acknowledge during accesses initiated by the ColdFire core that access default memory space.

- 0 = Wait for external transfer acknowledge for accesses initiated by the ColdFire core
- 1 = Generate internal transfer acknowledge with the number of wait states specified by WS[3:0] for accesses initiated by the ColdFire core

If AA=1 and \overline{TA} is asserted by the external system before the indicated number of wait states are generated, the assertion of \overline{TA} ends the transfer.

NOTE

Since the default memory address space incorporates all address space not specified as chip select or DRAM address space, be careful when setting the AA bit in the DMCR. If AA=1, an access to any address outside of the chip select and DRAM address spaces is terminated normally with an internal transfer acknowledge regardless of whether any memory exists in that location. If you need an Access Fault Exception to occur when a transfer attempts to access an address

outside of the chip select and DRAM address spaces, set AA to 0 in the DMCR and enable the Bus Timeout Monitor.

PS[1:0] - Port Size

This field specifies the width of the data associated with the default memory space. It determines which byte lanes are driven with valid data during write cycles and which byte lanes are sampled for valid data during read cycles.

Table 9-8. Port Size Encodings

PS[1:0]	PORT WIDTH	PORTION OF DATA BUS USED
00	32-bit port	D[31:0]
01	8-bit port	D[31:24]
10	16-bit port	D[31:16]
11	16-bit port	D[31:16]

EMAA - External Master Automatic Acknowledge Enable

This field controls the driving and assertion of \overline{TA} during accesses initiated by an external master.

- 0 = Do not drive \overline{TA} as an output during accesses initiated by an external master and wait for external transfer acknowledge
- 1 = Drive \overline{TA} as an output for accesses initiated by an external master and insert the number of wait states specified by WS[3:0]

NOTE

Because \overline{TA} is an output when $EMAA = 1$, \overline{TA} must not be driven by the external system. If \overline{TA} is asserted by the external system during external master transfer and $EMAA = 1$, damage to the part may occur. **Refer to Section 6: Bus Operations** for more information on the assertion and driving of \overline{TA} during external master accesses.

NOTE

Because the default memory address space incorporates all address space not specified as chip select or DRAM address space, be careful when setting the EMAA bit in the DMCR. If $EMAA=1$, an access initiated by an external master to any address outside of the chip select and DRAM address spaces are terminated normally with an internal transfer acknowledge regardless of whether any memory exists in that location. If you need an Access Fault Exception to occur when a transfer attempts to access an address outside of the chip select and DRAM address spaces, the external system must provide a transfer error acknowledge termination, because the internal

Bus Timeout Monitor does not monitor external master initiated transfers.

WRAH - Write Address Hold Enable

This field controls the address, data and attribute hold time after the termination (\overline{TA} , \overline{ATA} , \overline{TEA} , or internal transfer acknowledge) of a write cycle that hits in the default memory address space.

0 = Do not hold address extra cycle after the transfer is terminated on writes. See Figure 9-11.

1 = Hold address one cycle after the transfer is terminated on writes. See Figure 9-12.

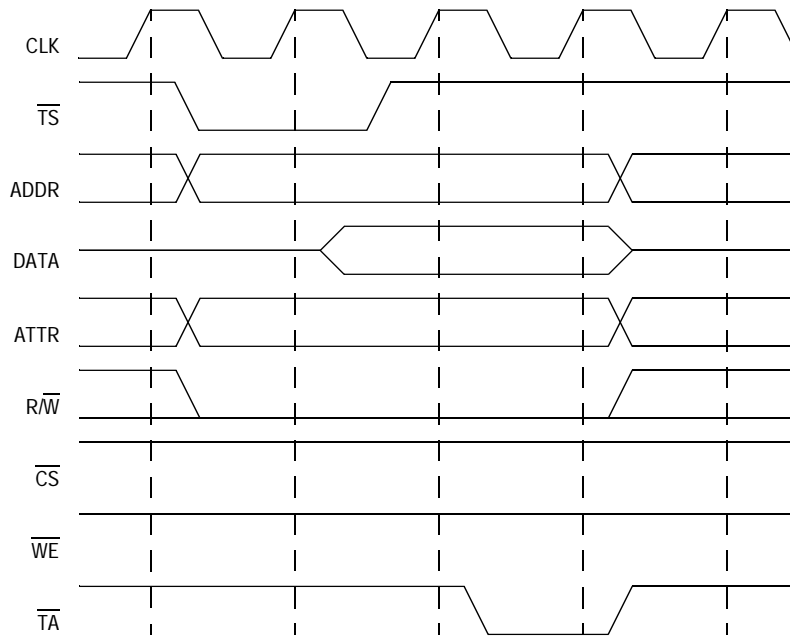

Figure 9-17. Default Memory Address Hold Timing with WRAH = 0

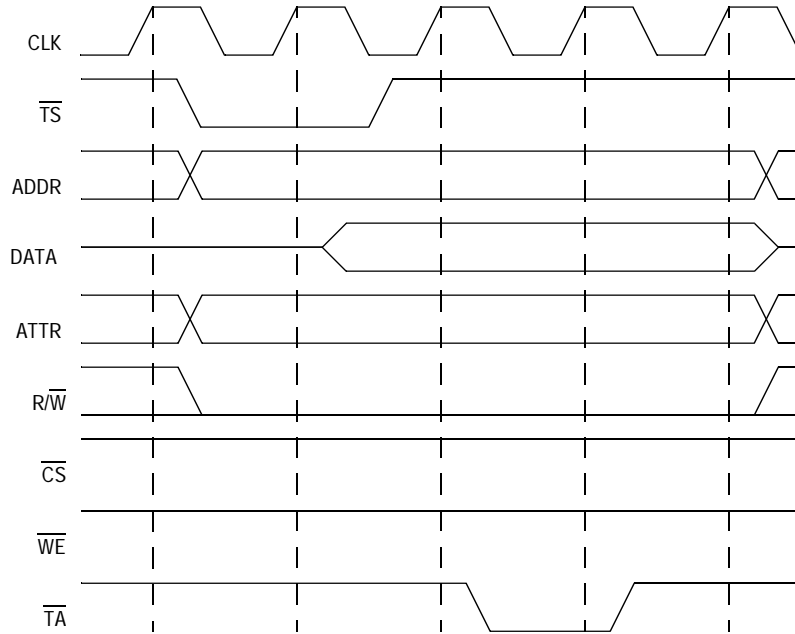

Figure 9-18. Default Memory Address Hold Timing with WRAH = 1

RDAH - Read Address Hold Enable

This field controls the address hold time after the termination (\overline{TA} , \overline{ATA} , \overline{TEA} , or internal transfer acknowledge) of a read cycle that hits in the default memory address space.

- 0 = Do not hold address extra cycle after the transfer is terminated on reads. See Figure 9-12.
- 1 = Hold address one cycle after the transfer is terminated on reads. See Figure 9-13.

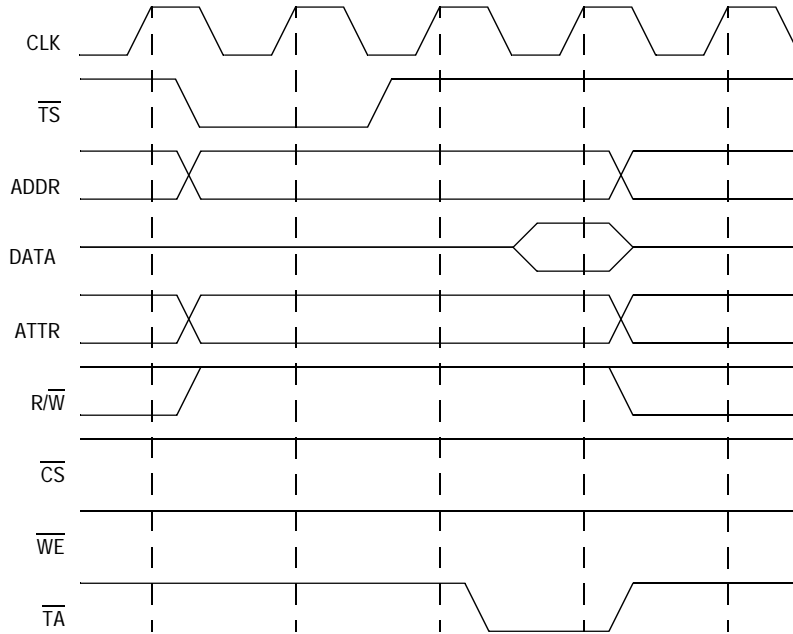

Figure 9-19. Default Memory Address Hold Timing with RDAH = 0

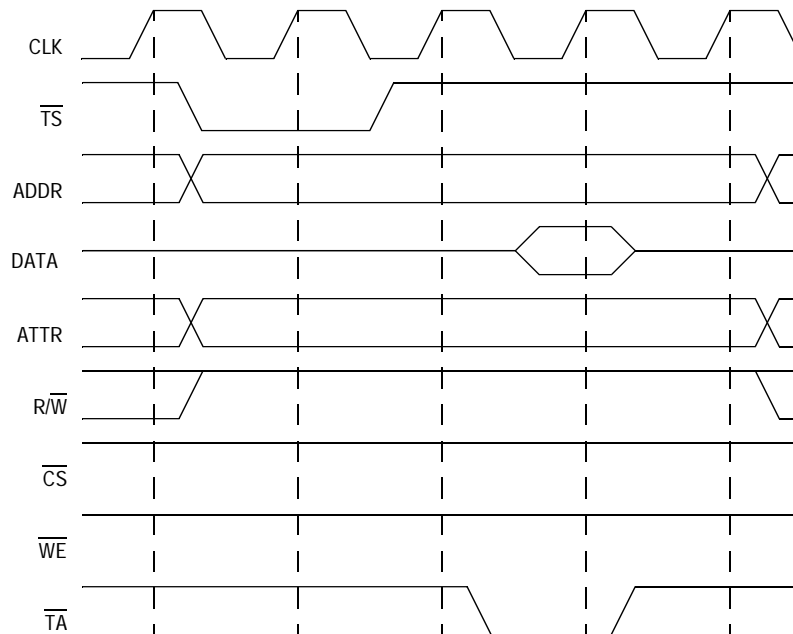

Figure 9-20. Default Memory Address Hold Timing with RDAH = 1

SECTION 10 PARALLEL PORT (GENERAL-PURPOSE I/O) MODULE

10.1 INTRODUCTION

The MCF5206e provides eight general-purpose input/output signals that can be used on a pin-by-pin basis. This subsection describes the operation and programming model of the parallel port registers and the direction-control and data registers.

10.2 PARALLEL PORT OPERATION

The MCF5206e parallel port module has eight signals that you can select as inputs or outputs on a pin-by-pin basis. These pins are multiplexed with the MCF5206e emulation pins and are programmed to their parallel port function through the Pin Assignment Register (PAR). Refer to the SIM subsection **6.3.2.10 Pin Assignment Register** for programming description.

10.3 PROGRAMMING MODEL

10.3.1 Parallel Port Registers Memory Map

Table 10-1 shows the memory map of all the parallel port registers. The internal registers in the parallel port module are memory-mapped registers offset from the MBAR address pointer. Refer to the SIM section for programming of the MBAR.

The following key notes apply to the programming model table:

- Addresses not assigned to a register and undefined register bits are reserved for future expansion. Write accesses to these reserved address spaces and reserved register bits have no effect; read accesses return zeros.
- The reset value column indicates the register initial value at reset. Certain registers can be uninitialized at reset.
- The access column indicates if the corresponding register allows both read/write functionality (R/W), read-only functionality (R), or write-only functionality (W). Any read-access attempts to a write-only register will return zeros. A write access to a read-only register attempt will be ignored and no write will occur.

Table 10-1. Memory Map of Parallel Port Registers

ADDRESS	NAME	WIDTH	DESCRIPTION	RESET VALUE	ACCESS
MBAR + \$1C5	PPDDR	8	Port A Data Direction Register	\$00	R/W
MBAR + \$1C9	PPDAT	8	Port A Data Register	\$00	R/W

10.3.2 Parallel Port Registers

10.3.2.1 PORT A DATA DIRECTION REGISTER (PADDR). The data direction register allows you to select the signal direction of each parallel port signal. There is one DDR bit in the PADDR for each parallel port signal. The data direction control bits will only affect the direction of the associated pin if you program that pin as a general-purpose I/O signal in the Pin Assignment Register (PAR). Refer to SIM subsection **6.3.2.10 Pin Assignment Register(PAR)** for programming details.

The DDR is an 8-bit read/write register. At system reset, all bits are initialized to zero.

Data Direction Register (DDR)				Address MBAR + \$1C5			
7	6	5	4	3	2	1	0
DDR7	DDR6	DDR5	DDR4	DDR3	DDR2	DDR1	DDR0
RESET:							
0	0	0	0	0	0	0	0
R/W							

DDR[7:0] - Data Direction Bits[7:0]

For each of the data direction bits, you can select the direction of the signal as follows:

- 0 = Signal is an input
- 1 = Signal is an output

Table 10-2 indicates how the bits in the data direction register are assigned to the PP[7:4]/DDATA[3:0] and PP[3:0]/PST[3:0] signal pins.

Table 10-2. Data Direction Register Bit Assignments

DATA DIRECTION REGISTER BIT	OUTPUT PIN
DDR7	PP[7]/DDATA[3]
DDR6	PP[6]/DDATA[2]
DDR5	PP[5]/DDATA[1]
DDR4	PP[4]/DDATA[0]
DDR3	PP[3]/PST[3]
DDR2	PP[2]/PST[2]
DDR1	PP[1]/PST[1]
DDR0	PP[0]/PST[0]

10.3.2.2 PORT A DATA REGISTER (PADAT). The parallel port data register reflects the current status of the parallel port signals. If you configure a parallel port signal as an input, the value in the register corresponds to the logical voltage level present at the pin. If you configure the parallel port signal as an output, the value in the register corresponds to the logical voltage level driven onto the pin.

SECTION 11 DRAM CONTROLLER

11.1 INTRODUCTION

The DRAM controller (DRAMC) provides a glueless interface between the ColdFire® core and external DRAM. The DRAMC supports two banks of DRAM. Each DRAM bank can be from 128 KByte to 256 MByte. The DRAMC can support DRAM bank widths of 8, 16, or 32 bits. Two row address strobe ($\overline{\text{RAS}}[1:0]$) signals are provided externally to access the two DRAM banks. Data byte lanes are enabled using the four column address strobe ($\overline{\text{CAS}}[3:0]$) signals. The DRAM write ($\overline{\text{DRAMW}}$) signal indicates if the DRAM transfer is a read or a write. The DRAMC handles address multiplexing internally, allowing for a glueless DRAM interface. The DRAMC has an internal refresh timer that generates $\overline{\text{CAS}}$ -before- $\overline{\text{RAS}}$ refresh cycles. You can program $\overline{\text{RAS}}$ and $\overline{\text{CAS}}$ waveform timing and refresh rates. External master use of the DRAMC for accessing the DRAM banks is also supported.

11.1.1 Features

The following list summarizes the key DRAMC features:

- Supports two banks of DRAM
- Supports Normal Mode, Fast Page Mode, and Burst Page Mode
- Supports EDO DRAMs
- Supports glueless row address/column address multiplexing
- Programmable $\overline{\text{RAS}}$ and $\overline{\text{CAS}}$ timings
- Programmable refresh timer for $\overline{\text{CAS}}$ -before- $\overline{\text{RAS}}$ refresh
- Supports external master use of the DRAMC

11.2 DRAM CONTROLLER I/O

11.2.1 Control Signals

The DRAMC has seven control signal signals: $\overline{\text{CAS}}[0]$, $\overline{\text{CAS}}[1]$, $\overline{\text{CAS}}[2]$, $\overline{\text{CAS}}[3]$, $\overline{\text{RAS}}[0]$, $\overline{\text{RAS}}[1]$, and $\overline{\text{DRAMW}}$.

11.2.1.1 ROW ADDRESS STROBES ($\overline{\text{RAS}}[0]$, $\overline{\text{RAS}}[1]$). These active-low output signals provide control for the row address strobe ($\overline{\text{RAS}}$) input pins on industry-standard DRAMs. There is one $\overline{\text{RAS}}$ output for each DRAM bank: $\overline{\text{RAS}}[0]$ controls DRAM bank 0 and $\overline{\text{RAS}}[1]$ controls DRAM bank 1. $\overline{\text{RAS}}$ timing can be customized to match the specifications of the DRAM being used by programming the DRAMC Timing Register (see **Section 11.4.2.2 DRAM Controller Timing Register (DCTR)**).

11.2.1.2 COLUMN ADDRESS STROBES ($\overline{\text{CAS}}[0]$, $\overline{\text{CAS}}[1]$, $\overline{\text{CAS}}[2]$, $\overline{\text{CAS}}[3]$). These active-low output signals provide control for the column address strobe (CAS) input pins on industry-standard DRAMs. The $\overline{\text{CAS}}$ signals are used to enable data byte lanes: $\overline{\text{CAS}}[0]$ controls access to D[31:24], $\overline{\text{CAS}}[1]$ to D[23:16], $\overline{\text{CAS}}[2]$ to D[15:8], and $\overline{\text{CAS}}[3]$ to D[7:0]. $\overline{\text{CAS}}[3:0]$ should be used for a 32-bit wide DRAM bank, $\overline{\text{CAS}}[1:0]$ for a 16-bit wide DRAM bank, and $\overline{\text{CAS}}[0]$ for an 8-bit wide DRAM bank. Table 11-1 shows which $\overline{\text{CAS}}$ signals are asserted based on the operand size, the DRAM port size and the address bits A[1:0]. For DRAM transfers SIZ[1:0] always matches the operand size.

Table 11-1. $\overline{\text{CAS}}$ Assertion

OPERAND SIZE	PORT SIZE	SIZ[1]	SIZ[0]	A[1]	A[0]	$\overline{\text{CAS}}[0]$	$\overline{\text{CAS}}[1]$	$\overline{\text{CAS}}[2]$	$\overline{\text{CAS}}[3]$	
						D[31:24]	D[23:16]	D[15:8]	D[7:0]	
BYTE	8-BIT	0	1	0	0	0	1	1	1	
				0	1	0	1	1	1	
				1	0	0	1	1	1	
				1	1	0	1	1	1	
	16-BIT	0	1	0	0	0	1	1	1	
				0	1	1	0	1	1	
				1	0	0	1	1	1	
				1	1	1	0	1	1	
	32-BIT	0	1	0	0	0	1	1	1	
				0	1	1	0	1	1	
				1	0	1	1	0	1	
				1	1	1	1	1	0	
WORD	8-BIT	1	0	0	0	0	1	1	1	
				0	1	0	1	1	1	
				1	0	0	1	1	1	
				1	1	0	1	1	1	
	16-BIT	1	0	0	0	0	0	1	1	
				1	0	0	0	1	1	
	32-BIT	1	0	0	0	0	0	1	1	
				1	0	1	1	0	0	
	LONGWORD	8-BIT	0	0	0	0	0	1	1	1
					0	1	0	1	1	1
					1	0	0	1	1	1
					1	1	0	1	1	1
16-BIT		0	0	0	0	0	0	1	1	
				1	0	0	0	1	1	
32-BIT		0	0	0	0	0	0	0	0	

Table 11-1. $\overline{\text{CAS}}$ Assertion (Continued)

OPERAND SIZE	PORT SIZE	SIZ[1]	SIZ[0]	A[1]	A[0]	$\overline{\text{CAS}}[0]$	$\overline{\text{CAS}}[1]$	$\overline{\text{CAS}}[2]$	$\overline{\text{CAS}}[3]$
						D[31:24]	D[23:16]	D[15:8]	D[7:0]
LINE	8-BIT	1	1	0	0	0	1	1	1
				0	1	0	1	1	1
				1	0	0	1	1	1
				1	1	0	1	1	1
	16-BIT	1	1	0	0	0	0	1	1
				1	0	0	0	1	1
32-BIT	1	1	0	0	0	0	0	0	

$\overline{\text{CAS}}$ timing can be customized to match the specifications of the DRAM by programming the DRAM Controller Timing Register (see **Section 11.4.2.2 DRAM Controller Timing Register (DCTR)**).

11.2.1.3 DRAM WRITE ($\overline{\text{DRAMW}}$). This active-low output signal is asserted during DRAM write cycles, and negated during DRAM read cycles. The $\overline{\text{DRAMW}}$ signal is negated during refresh cycles. The $\overline{\text{DRAMW}}$ signal is provided in addition to the R/W signal to allow refreshes to occur during nonDRAM cycles (regardless of the state of the R/W signal). The R/W signal indicates the direction of all bus transfers, while $\overline{\text{DRAMW}}$ is only valid during DRAM transfers.

11.2.2 Address Bus

The address bus includes 24 dedicated address signals, A[23:0], and supports as many as four additional configurable address signals, A[27:24] (refer to **Section 7.3.2.10 Pin Assignment Register (PAR)**). The DRAM address appears only on the pins configured to be address signals. The maximum size of DRAM that can be connected to each bank is limited by the number of address signals available (see Table 11-2).

Table 11-2. Maximum DRAM Bank Sizes

AVAILABLE ADDRESS SIGNALS	MAXIMUM DRAM SIZE
A[23:0]	16 MBytes
A[24:0]	32 MBytes
A[25:0]	64 MBytes
A[26:0]	128 MBytes
A[27:0]	256 MBytes

For transfers initiated by the ColdFire core, the DRAMC outputs both the row address and the column address, allowing the address bus to be directly connected to external DRAM. The internal address multiplexing can be selectively enabled for transfers initiated by an external master by programming the DAEM bit in the DCTR (see **Section 11.4.2.2 DRAM Controller Timing Register (DCTR)**).

11.2.3 Data Bus

The DRAM banks can be configured to be 8, 16, or a 32-bits wide. A 32-bit port must reside on data bus bits D[31:0], a 16-bit port must reside on data bus bits D[31:16] and an 8-bit port must reside on data bus bits D[31:24]. This requirement ensures that the MCF5206e correctly transfers valid data to 8, 16 and 32-bit ports. Figure 11-1 illustrates the connection of the data bus to 8-, 16-, and 32-bit ports.

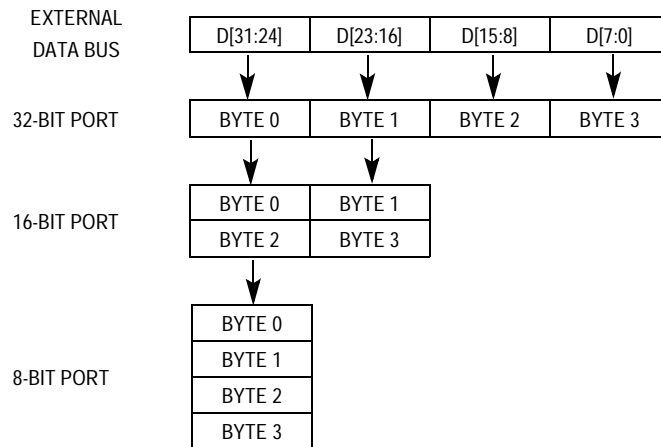

Figure 11-1. MCF5206e Interface to Various Port Sizes

11.3 DRAM CONTROLLER OPERATION

The DRAMC provides a glueless interface to industry-standard DRAMs. The following sections describe the reset operation, definition of DRAM banks, normal mode, Fast Page Mode, burst page mode, Extended Data-Out DRAM support, refresh operation, and external master operation.

NOTE

All timing diagrams in the following sections illustrate the fastest possible waveform timing; however, in all cases, the DRAM Controller Timing Register (DCTR) can be programmed to generate slower waveform timing.

11.3.1 Reset Operation

The MCF5206e supports two types of external hardware reset—Master Reset and Normal Reset. Master Reset resets the entire MCF5206e including all functions of the DRAMC. Normal Reset resets all of the functions of the MCF5206e with the exception of the DRAMC Refresh Controller. During Normal Resets, the Refresh Controller continues to generate refresh cycles at the programmed rate and with the programmed cycle timing.

NOTE

Master Reset must be asserted for all power-on resets. Failure to assert Master Reset on power-on reset could result in unpredictable DRAMC behavior.

11.3.1.1 MASTER RESET. During a master reset all registers in the DRAMC are initialized to a known state and all DRAMC operation is halted. The DRAM refresh counter does not count and DRAM refresh cycles are not generated. Any DRAM transfer or refresh cycle in progress is immediately terminated.

A master reset is accomplished by asserting and negating the $\overline{\text{RSTI}}$ and $\overline{\text{HIz}}$ signals simultaneously, these signals are both synchronized (with setup) to the falling edge of CLK (see **Section 6.11 reset Operation**).

NOTE

During a master reset, the DCCR is reset to \$000 (giving the slowest refresh rate) and the DCTR is reset to \$0000 (giving the fastest waveform timing). After a Master Reset, the user should program the DRAMC Refresh Register (DCRR) and the DRAMC Timing Register (DCTR) such that refresh cycles are generated at the required rate and with the required timing for the DRAM in the system. In general, DRAMs require an initial pause after power-up and require a minimum number of DRAM cycles to be run before the DRAM is ready for use. This “wake-up” sequence must be handled via software.

11.3.1.2 NORMAL RESET. Normal reset is used when the DRAM contains valid data which needs to be maintained through reset. The DRAMC Refresh Register (DCRR), DRAMC Timing Register (DCTR), and the internal DRAMC Refresh controller are unaffected by normal reset. All other MCF5206e registers are reset to the same values during normal resets as during Master Resets. During normal reset, DRAM refreshes occurs at the programmed rate and with the programmed DRAM cycle timing.

A normal reset is accomplished by asserting the $\overline{\text{RSTI}}$ signal while negating the $\overline{\text{HIz}}$ signal. Resets generated by the internal software watchdog timer are normal resets.

11.3.2 Definition of DRAM Banks

The DRAMC supports as many as two banks of DRAM. You can program each bank independently except for the $\overline{\text{RAS}}$ and $\overline{\text{CAS}}$ waveform timing (programming the DCTR affects the waveform timing for both banks).

11.3.2.1 BASE ADDRESS AND ADDRESS MASKING. The transfer address generated by the ColdFire core or by an external master is compared to the unmasked bits of the base address programmed for each bank in the DRAMC Address Registers (DCAR0 -

DCAR1). The bits that are masked is determined by the value programmed in the BAM field in the DRAMC Mask Registers (DCMR0 - DCMR1).

The masking of address bits is used to define the address space of the DRAM bank. Address bits that are masked are not used in the comparison with the transfer address. The base address field (BA31-BA17) in the DCARs and the base address mask field (BAM31-BAM17) in the DCMRs correspond to transfer address bits 31-17. Clearing (unmasking) all bits in the BAM field makes the address space 128 KBytes. For the address space of a DRAM bank to be contiguous, address bits should be masked (BAM bits set to a 1) in ascending order starting with A[17].

For example, if the DCARs and DCMRs are programmed as shown in Table 11-3, DRAM bank 0 would have a 16 MByte address space starting at address \$04000000, while DRAM bank 1 would have a 1 MByte address space starting at address \$05000000. A transfer with A[31:24] = \$04 accesses DRAM bank 0, and a transfer address with A[31:20] = \$050 accesses DRAM bank 1.

Table 11-3. DRAM Bank Programming Example 1

DRAM BANK	DCAR	DCMR	DRAM ADDRESS SPACE	ADDRESS MATCH
0	\$0400	\$00FE0000	16 Mbyte	\$04xxxxxx
1	\$0500	\$000E0000	1 Mbyte	\$050xxxxx

Refer to **Section 11.4.2.3 DRAM Controller Address Register (DCAR0 - DCAR1)** and **Section 11.4.2.4 DRAM Controller Mask Register (DCMR0 - DCMR1)** for further details.

NOTE

The ColdFire core outputs 32 bits of address to the internal bus controller. Of these 32 bits, only A[27:0] are output to pins on the MCF5206e. The output of A[27:24] are dependent on the setting of PAR3-PAR0 in the Pin Assignment Register (PAR) in the SIM.

NOTE

The MCF5206e compares the address for the current bus transfer with the address and mask bits in the Chip Select Address Registers (CSARs), DRAM Controller Address Registers (DCARs) and the Chip Select Mask Registers (CSMRs) and DRAM Controller Mask Register (DCMRs),

looking for a match. The priority is listed in Table 11-4 (from highest priority to lowest priority):

Table 11-4. Chip Select, DRAM and Default Memory Address Decoding Priority

Highest priority	Chip select 0
	Chip select 1
	Chip select 2
	Chip select 3
	Chip select 4
	Chip select 5
	Chip select 6
	Chip select 7
	DRAM Bank 0
	DrRAM Bank 1
Lowest priority	Default Memory

The MCF5206e compares the address and mask in chip select 0 - 7 (chip select 0 is compared first), then the address and mask in DRAM 0 - 1. If the address does not match in either or these, the MCF5206e uses the control bits in the Default Memory Control Register (DMCR) to control the bus transfer. If the Default Memory Control Register (DMCR) control bits are used, no chip select or DRAM control signals are asserted during the transfer.

11.3.2.2 ACCESS PERMISSIONS. DRAM bank accesses can be restricted based on transfer direction and attributes. Each DRAM bank can be enabled for read and/or write transfers using the WR and RD bits in the DCCRs. Each DRAM bank can have supervisor data, supervisor code, user data, and user code transfers masked from their address space using the SD, SC, UD, and UC bits in the DCMRs. The transfer address must match, the transfer direction must be enabled, and transfer attributes must be unmasked for a transfer to a DRAM bank to occur.

For example, if the DCARs, DCMRs, and DCCRs are programmed as shown in Table 11-5, DRAM bank 0 would start at address \$04000000, and be 16 MBytes, read/write, and available for supervisor transfers only. DRAM bank 1 would start at address \$05000000 and be 1 MBytes, read-only, and available to all address spaces.

If a user data read transfer was attempted to address \$04000000, the transfer would not access DRAM bank 0, because user space transfers are masked. The transfer would not access DRAM bank 1 because the addresses do not match. Therefore, a Default Memory transfer would occur.

If a user data write transfer was attempted to address \$05000000, the transfer would not access DRAM bank 0 because the addresses do not match. The transfer would not access DRAM bank 1 because this bank is not enabled for writes. Therefore, a Default Memory transfer would occur.

Table 11-5. DRAM Bank Programming Example 2

DRAM BANK	DCAR	DCMR	DCCR	ADDRESS MATCH	TRANSFER TYPE	READ/WRITE
0	\$0400	\$00FE0006	\$03	\$04xxxxxx	supervisor-only	read/write
1	\$0500	\$000E0000	\$01	\$050xxxxx	all transfer types	read-only

Refer to **Section 11.4.2.4 DRAM Controller Mask Register (DRMR0 - DCMR1)** and **Section 11.4.2.5 DRAM Controller Control Register (DCCR0 - DCCR1)** for further details.

11.3.2.3 TIMING. The timing of $\overline{\text{RAS}}$ and $\overline{\text{CAS}}$ assertion and negation can be customized to meet the timing specifications for the specific DRAM being used. This programmed waveform timing is used for both banks. Refer to **Section 11.4.2.2 DRAM Controller Timer Register (DCTR)** for further details.

11.3.2.4 PAGE MODE. Each bank can be configured for normal mode, fast page mode, or burst page mode. Normal mode DRAM cycles supply a row address and a column address for each transfer. Fast page mode DRAM cycles supply a row address and a column address for the first transfer to a page and only a column address on successive transfers to that page. Burst page mode is a combination of normal mode and fast page mode. For transfers where the port size is larger or the same as the operand size (non-burst transfers), burst page mode operates the same as normal mode. For transfers where the operand size is larger than the port size (burst transfers), burst page mode operates the same as fast page mode. Refer to **11.3.3 Normal Mode Operation**, **11.3.4 Fast Page Mode Operation**, **11.3.5 Burst Page Mode Operation**, and **Section 11.4.2.5 DRAM Controller Control Register (DCCR0 - DCCR1)** for further details.

11.3.2.5 PORT SIZE/PAGE SIZE. Each DRAM bank can be programmed for 8-, 16-, or 32-bit port sizes. Each bank can also have an internal bank page size of 512 byte, 1 kbyte, or 2 kbyte. Refer to **Section 11.4.2.5 DRAM Controller Control Register (DCCR0 - DCCR1)** for further details.

11.3.2.6 ADDRESS MULTIPLEXING. The MCF5206e provides internal address multiplexing of the row address and column address for DRAM transfers. The internal address multiplexing is used for all ColdFire core initiated DRAM transfers and can selectively be used for external master initiated DRAM transfers. No external logic is required in the system to handle DRAM address multiplexing when the internal multiplexing is used. In addition, the multiplexing scheme allows a single printed circuit board layout to support multiple DRAM memory sizes (allowing for easy memory upgrades).

A subset of the address pins should be connected directly to the address inputs of the DRAM to supply the row address and column address. The DRAM port size and bank page size determine which address pins should be connected to the address inputs of the DRAM. In Figure 11-2, the address multiplexing scheme is illustrated for an 8-bit DRAM with 9 address inputs using a 512 byte page size (PS=01 and BPS=00 in the DCCR). In this case, the DRAM address inputs (DA[x]) would be connected to the MCF5206e

address pins (A[x]) in the following order: A[9] to DA[0], A[10] to DA[1], A[11] to DA[2], A[12] to DA[3], A[13] to DA[4], A[14] to DA[5], A[15] to DA[6], A[16] to DA[7], and A[17] to DA[8].

When the ColdFire core initiates a transfer to an address location in the DRAM, the MCF5206e drives the internal transfer address IA[27:0] onto the MCF5206e address pins A[27:0] and asserts $\overline{\text{RAS}}$. This places the internal transfer address bits IA[17:9] into the DRAM as the row address. Then the MCF5206e internally multiplexes and drive the internal transfer address bits IA[8:0] onto the MCF5206e address pins A[17:9] and asserts $\overline{\text{CAS}}$. This places the internal transfer address bits IA[8:0] into the DRAM as the column address.

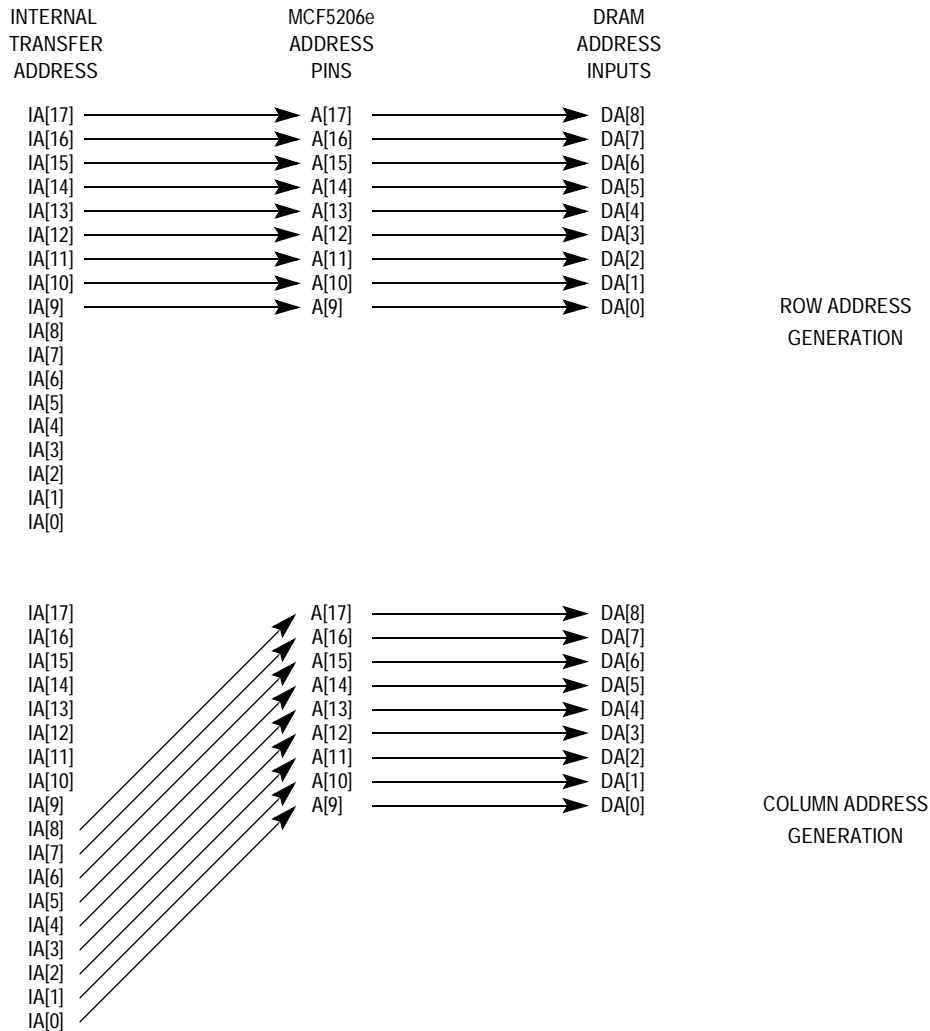

Figure 11-2. Address Multiplexing For 8-bit DRAM With 512 Byte Page Size

The port size (PS) and the bank page size (BPS) determine which address bus pins are used to drive the row address and column address. Tables 11-6, 11-7, and 11-8 show which internal transfer address bits are driven on each address pin during the assertion of $\overline{\text{RAS}}$ and during the assertion of $\overline{\text{CAS}}$ for all combinations of port size (PS) and bank page

size (BPS). The shaded address pins in each PS/BPS configuration outputs the row address during the assertion of $\overline{\text{RAS}}$ and the column address during the assertion of $\overline{\text{CAS}}$. These signals should be connected to the DRAM address inputs. The number of address signals used depends on the size of the DRAM. Because byte $\overline{\text{CAS}}$ signals ($\overline{\text{CAS}}$

Table 11-6. 8-bit Port Size Address Multiplexing Configurations

MCF5206E ADDRESS PIN	PS = 8-BIT BPS = 512 BYTE		MCF5206E ADDRESS PIN	PS = 8-BIT BPS = 1 KBYTE		MCF5206E ADDRESS PIN	PS = 8-BIT BPS = 2 KBYTE	
	ROW ADDRESS	COLUMN ADDRESS		ROW ADDRESS	COLUMN ADDRESS		ROW ADDRESS	COLUMN ADDRESS
A[27]	IA[27]	IA[26]	A[27]	IA[27]	IA[26]	A[27]	IA[27]	IA[26]
A[26]	IA[26]	IA[26]	A[26]	IA[26]	IA[26]	A[26]	IA[26]	IA[26]
A[25]	IA[25]	IA[24]	A[25]	IA[25]	IA[24]	A[25]	IA[25]	IA[24]
A[24]	IA[24]	IA[24]	A[24]	IA[24]	IA[24]	A[24]	IA[24]	IA[24]
A[23]	IA[23]	IA[22]	A[23]	IA[23]	IA[22]	A[23]	IA[23]	IA[22]
A[22]	IA[22]	IA[22]	A[22]	IA[22]	IA[22]	A[22]	IA[22]	IA[22]
A[21]	IA[21]	IA[20]	A[21]	IA[21]	IA[20]	A[21]	IA[21]	IA[10]
A[20]	IA[20]	IA[20]	A[20]	IA[20]	IA[20]	A[20]	IA[20]	IA[9]
A[19]	IA[19]	IA[18]	A[19]	IA[19]	IA[9]	A[19]	IA[19]	IA[8]
A[18]	IA[18]	IA[18]	A[18]	IA[18]	IA[8]	A[18]	IA[18]	IA[7]
A[17]	IA[17]	IA[8]	A[17]	IA[17]	IA[7]	A[17]	IA[17]	IA[6]
A[16]	IA[16]	IA[7]	A[16]	IA[16]	IA[6]	A[16]	IA[16]	IA[5]
A[15]	IA[15]	IA[6]	A[15]	IA[15]	IA[5]	A[15]	IA[15]	IA[4]
A[14]	IA[14]	IA[5]	A[14]	IA[14]	IA[4]	A[14]	IA[14]	IA[3]
A[13]	IA[13]	IA[4]	A[13]	IA[13]	IA[3]	A[13]	IA[13]	IA[2]
A[12]	IA[12]	IA[3]	A[12]	IA[12]	IA[2]	A[12]	IA[12]	IA[1]
A[11]	IA[11]	IA[2]	A[11]	IA[11]	IA[1]	A[11]	IA[11]	IA[0]
A[10]	IA[10]	IA[1]	A[10]	IA[10]	IA[0]	A[10]	IA[10]	IA[10]
A[9]	IA[9]	IA[0]	A[9]	IA[9]	IA[9]	A[9]	IA[9]	IA[9]

Table 11-7. 16-bit Port Size Address Multiplexing Configurations

MCF5206E ADDRESS PIN	PS = 16-BIT BPS = 512 BYTE		MCF5206E ADDRESS PIN	PS = 16-BIT BPS = 1 KBYTE		MCF5206E ADDRESS PIN	PS = 16-BIT BPS = 2 KBYTE	
	ROW ADDRESS	COLUMN ADDRESS		ROW ADDRESS	COLUMN ADDRESS		ROW ADDRESS	COLUMN ADDRESS
A[27]	IA[27]	IA[27]	A[27]	IA[27]	IA[27]	A[27]	IA[27]	IA[27]
A[26]	IA[26]	IA[25]	A[26]	IA[26]	IA[25]	A[26]	IA[26]	IA[25]
A[25]	IA[25]	IA[25]	A[25]	IA[25]	IA[25]	A[25]	IA[25]	IA[25]
A[24]	IA[24]	IA[23]	A[24]	IA[24]	IA[23]	A[24]	IA[24]	IA[23]
A[23]	IA[23]	IA[23]	A[23]	IA[23]	IA[23]	A[23]	IA[23]	IA[23]
A[22]	IA[22]	IA[21]	A[22]	IA[22]	IA[21]	A[22]	IA[22]	IA[21]
A[21]	IA[21]	IA[21]	A[21]	IA[21]	IA[21]	A[21]	IA[21]	IA[21]
A[20]	IA[20]	IA[19]	A[20]	IA[20]	IA[19]	A[20]	IA[20]	IA[10]
A[19]	IA[19]	IA[19]	A[19]	IA[19]	IA[19]	A[19]	IA[19]	IA[9]
A[18]	IA[18]	IA[17]	A[18]	IA[18]	IA[9]	A[18]	IA[18]	IA[8]
A[17]	IA[17]	IA[17]	A[17]	IA[17]	IA[8]	A[17]	IA[17]	IA[7]
A[16]	IA[16]	IA[8]	A[16]	IA[16]	IA[7]	A[16]	IA[16]	IA[6]
A[15]	IA[15]	IA[7]	A[15]	IA[15]	IA[6]	A[15]	IA[15]	IA[5]
A[14]	IA[14]	IA[6]	A[14]	IA[14]	IA[5]	A[14]	IA[14]	IA[4]
A[13]	IA[13]	IA[5]	A[13]	IA[13]	IA[4]	A[13]	IA[13]	IA[3]
A[12]	IA[12]	IA[4]	A[12]	IA[12]	IA[3]	A[12]	IA[12]	IA[2]
A[11]	IA[11]	IA[3]	A[11]	IA[11]	IA[2]	A[11]	IA[11]	IA[1]
A[10]	IA[10]	IA[2]	A[10]	IA[10]	IA[1]	A[10]	IA[10]	IA[10]
A[9]	IA[9]	IA[1]	A[9]	IA[9]	IA[9]	A[9]	IA[9]	IA[9]

Freescale Semiconductor, Inc.

Table 11-8. 32-bit Port Size Address Multiplexing Configurations

MCF5206E ADDRESS PIN	PS = 32-BIT BPS = 512 BYTE		MCF5206E ADDRESS PIN	PS = 32-BIT BPS = 1 KBYTE		MCF5206E ADDRESS PIN	PS = 32-BIT BPS = 2 KBYTE	
	ROW ADDRESS	CAS		ROW ADDRESS	CAS		ROW ADDRESS	CAS
A[27]	IA[27]	IA[26]	A[27]	IA[27]	IA[26]	A[27]	IA[27]	IA[26]
A[26]	IA[26]	IA[26]	A[26]	IA[26]	IA[26]	A[26]	IA[26]	IA[26]
A[25]	IA[25]	IA[24]	A[25]	IA[25]	IA[24]	A[25]	IA[25]	IA[24]
A[24]	IA[24]	IA[24]	A[24]	IA[24]	IA[24]	A[24]	IA[24]	IA[24]
A[23]	IA[23]	IA[22]	A[23]	IA[23]	IA[22]	A[23]	IA[23]	IA[22]
A[22]	IA[22]	IA[22]	A[22]	IA[22]	IA[22]	A[22]	IA[22]	IA[22]
A[21]	IA[21]	IA[20]	A[21]	IA[21]	IA[20]	A[21]	IA[21]	IA[20]
A[20]	IA[20]	IA[20]	A[20]	IA[20]	IA[20]	A[20]	IA[20]	IA[20]
A[19]	IA[19]	IA[18]	A[19]	IA[19]	IA[18]	A[19]	IA[19]	IA[10]
A[18]	IA[18]	IA[18]	A[18]	IA[18]	IA[18]	A[18]	IA[18]	IA[9]
A[17]	IA[17]	IA[16]	A[17]	IA[17]	IA[9]	A[17]	IA[17]	IA[8]
A[16]	IA[16]	IA[16]	A[16]	IA[16]	IA[8]	A[16]	IA[16]	IA[7]
A[15]	IA[15]	IA[8]	A[15]	IA[15]	IA[7]	A[15]	IA[15]	IA[6]
A[14]	IA[14]	IA[7]	A[14]	IA[14]	IA[6]	A[14]	IA[14]	IA[5]
A[13]	IA[13]	IA[6]	A[13]	IA[13]	IA[5]	A[13]	IA[13]	IA[4]
A[12]	IA[12]	IA[5]	A[12]	IA[12]	IA[4]	A[12]	IA[12]	IA[3]
A[11]	IA[11]	IA[4]	A[11]	IA[11]	IA[3]	A[11]	IA[11]	IA[2]
A[10]	IA[10]	IA[3]	A[10]	IA[10]	IA[2]	A[10]	IA[10]	IA[10]
A[9]	IA[9]	IA[2]	A[9]	IA[9]	IA[9]	A[9]	IA[9]	IA[9]

The BPS field in each DCCR defines the DRAMC internal page size. The internal page size is used by the DRAMC to determine whether a transfer is a page hit or a page miss. The page size of the DRAM used in the bank is not always the same as the DRAMC internal page size. For example, if a 2 KByte page size is selected and an 8-bit wide DRAM is used, 11 address bits and 1 CAS signal are needed to define the page. However, if a 2 KByte page size is selected and a 32-bit wide DRAM is used, only 9 address signals and 4 CAS signals are needed to define the page. Using a DRAM which has a larger page size than is listed in the Actual DRAM Page Size column of Table 11-9 for a given internal page size and port size gives no performance advantage.

To allow for future upgrades to larger DRAMs without requiring multiple printed circuit board layouts, the page size must remain constant. After the page size has been selected, use the tables to determine which address pins to use for the maximum DRAM size. These traces can then be routed to the DRAM socket on the printed circuit board.

Table 11-9. Bank Page Size Versus Actual DRAM Page Size

BANK PAGE SIZE (BPS)	PORT SIZE	PAGE ADDRESS	ACTUAL DRAM PAGE SIZE
512 Bytes	8 bits	A[8:0]	512 Bytes
	16 bits	A[8:1]	256 Bytes
	32 bits	A[8:2]	128 Bytes
1 KByte s	8 bits	A[9:0]	1 KBytes
	16 bits	A[9:1]	512 Bytes
	32 bits	A[9:2]	256 Bytes
2 KBytes	8 bits	A[10:0]	2 KBytes
	16 bits	A[10:1]	1 KBytes
	32 bits	A[10:2]	512 Bytes

From a hardware point of view, a smaller DRAM is simply not connected to the upper address pins. When a larger DRAM is installed, all address pins are connected. From a software point of view, the DRAMC Mask Register (DCMR) contents are modified to mask more of the address bits for the larger DRAM. The bank page size (BPS) in the DRAMC Control Register (DCCR) must remain the same, even if the larger DRAM can support a larger page size. If the BPS field is changed, the address multiplexing also changes—requiring a different printed circuit board layout.

For example, suppose the system DRAM is 8 bits wide and can range from 1 MByte (1 M x 8 bits) to 4 MBytes (4 M x 8 bits), with a page size of 1 KByte. Referring to Table 11-8, address pins A[10:19] and A[21] should be routed to the DRAM socket pins. For the 4 M x 8 DRAM, the MCF5206e address pins A[10:19] and A[21] are connected to the DRAM address inputs A[0:10] (see Figure 11-3). For the 1 M x 8 DRAM, the MCF5206e address pins A[10:19] are connected to the DRAM address inputs A[0:9] (see Figure 11-4). Because the address connections for the 1 M x 8 are a subset of those for the 4 M x 8, the address multiplexing scheme allows a system using the MCF5206e to upgrade the memory size without requiring different printed circuit board layouts. The only required change is the number of bits masked in the DCMR.

It should be noted that the page size, in this example, is determined by the 1 M x 8 DRAM (9 column address bits gives a page size of 1 KByte), and that even though the 4 M x 8 DRAM could support a 2 KByte page size, the page size must be programmed to 1 KByte to keep the address multiplexing the same.

For the 4 M x 8 DRAM, the DCCR and DCMR would be programmed as follows:

DCCR: \$57 (port size = 8 bits, page size = 1KByte, burst page mode, read/write)
 DCMR: \$001E0000 (A[20:17] are masked => 4 MByte)

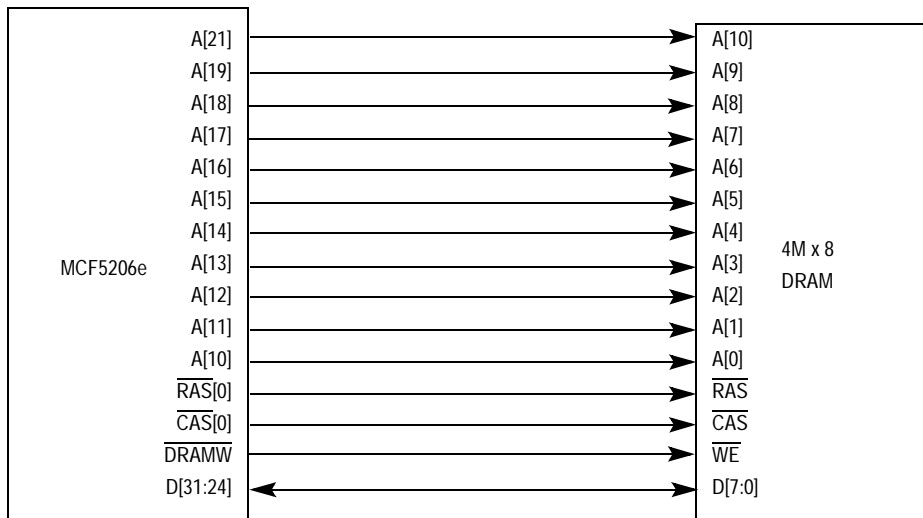

Figure 11-3. Diagram for 4 MByte DRAM with 8 bit Port and 1 KByte Page

For the 1 M x 8 DRAM, the DCCR and DCMR would be programmed as follows:

DCCR: \$57 (port size = 8 bits, page size = 1KByte, burst page mode, read/write)
 DCMR: \$000E0000 (A[19:17] are masked => 1 MByte).

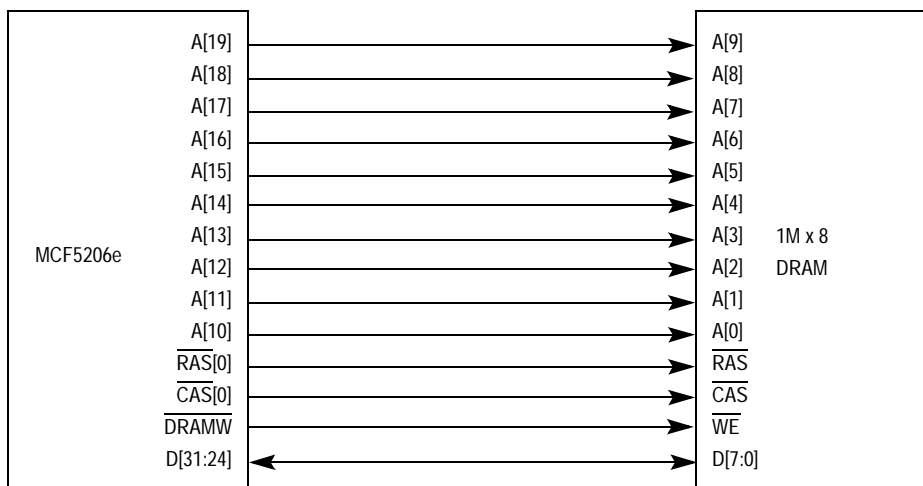

Figure 11-4. Diagram for 1 MByte DRAM with 8 Bit Port and 1 KByte Page

11.3.3 Normal Mode Operation

Normal mode is the simplest form of DRAM transfer. In this mode, row addresses and column addresses are supplied for every transfer. For DRAM transfers initiated by the ColdFire core that access a bank programmed for normal mode, the MCF5206e supplies a row address on the address bus, drives DRAMW to indicate whether a read or a write

is occurring and asserts $\overline{\text{RAS}}$. The MCF5206e then drives the column address onto the same address pins and asserts $\overline{\text{CAS}}$. When the cycle is complete, both $\overline{\text{RAS}}$ and $\overline{\text{CAS}}$ are negated.

11.3.3.1 NONBURST TRANSFER IN NORMAL MODE. A nonburst transfer to DRAM occurs when the operand size is the same or smaller than the DRAM port size (e.g., longword transfer to a 32-bit port, or byte transfer to a 16-bit port). Nonburst transfers always start with the assertion of $\overline{\text{TS}}$.

The start of a transfer to a DRAM bank can be delayed by the DRAMC until the programmed $\overline{\text{RAS}}$ precharge time is met. A transfer to a different DRAM bank than the previous transfer is never delayed due to $\overline{\text{RAS}}$ precharge because that bank has already been precharged.

The timing of nonburst reads and nonburst writes is identical in normal page mode, with the exception of when the DRAM drives data on reads and when the MCF5206e drives data on writes.

The fastest possible nonburst transfer in normal mode requires 3 clocks with a 1.5 clock $\overline{\text{RAS}}$ precharge time. You can program the DCTR to generate slower normal mode transfers.

Figure 11-5 shows the timing of a back-to-back nonburst byte-read transfer to an 8-bit port in normal mode.

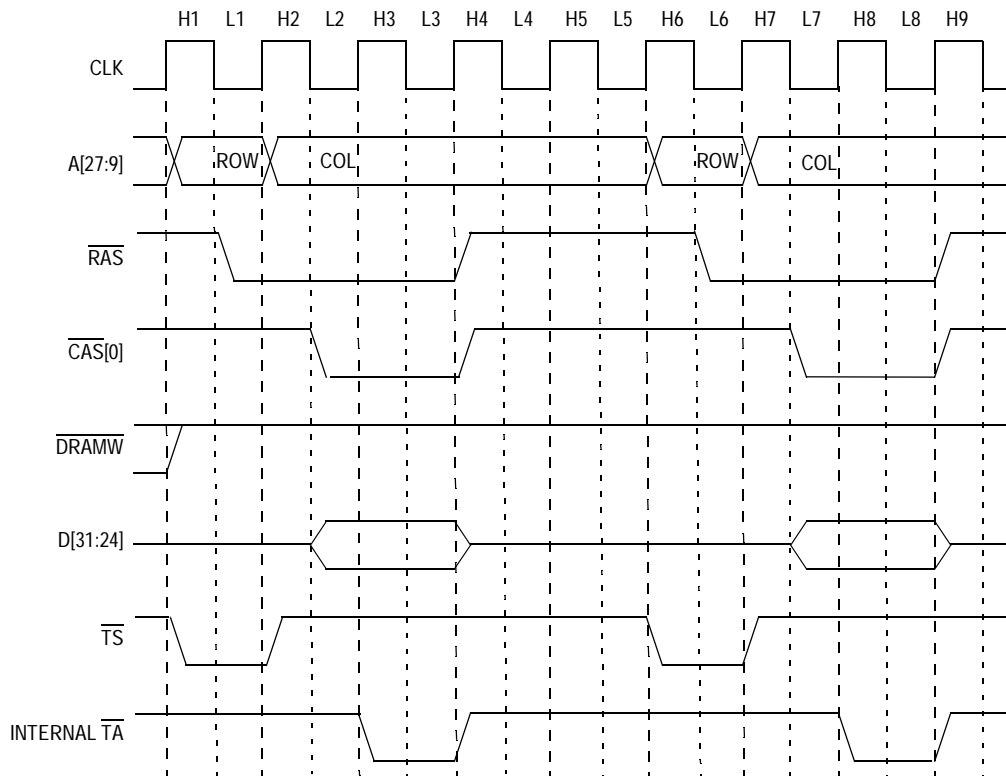

Figure 11-5. Byte Read Transfers in Normal Mode with 8-bit DRAM

Clock H1

The first DRAM-read transfer starts in H1. During H1, the MCF5206e drives the row address on the A[27:9], drives $\overline{\text{DRAMW}}$ high indicating a DRAM read transfer, drives SIZ[1:0] to \$1 indicating a byte transfer, and asserts $\overline{\text{TS}}$.

Clock L1

The MCF5206e asserts $\overline{\text{RAS}}$ to indicate the row address is valid on the address bus.

Clock H2

The MCF5206e negates $\overline{\text{TS}}$ and drives the column address on the address bus.

Clock L2

The MCF5206e asserts $\overline{\text{CAS}}[0]$ to indicate the column address is valid on the address bus. At this point, the DRAM turns on its output drivers and begins driving data on D[31:24].

Clock H3

The internal transfer acknowledge asserts to indicate that the current transfer is completed and the data on the D[31:24] will be registered on the next rising edge of CLK.

Clock H4

The MCF5206e registers the read data driven by the DRAM and negates the internal transfer acknowledge, $\overline{\text{RAS}}$ and $\overline{\text{CAS}}[0]$, ending the first byte-read transfer. This begins the $\overline{\text{RAS}}$ precharge. Once $\overline{\text{CAS}}[0]$ is negated, the DRAM disables its output drivers, and the data bus is three-stated.

Clock H6

Clock H6 is the earliest the next transfer initiated by the ColdFire core can start. The second DRAM byte-read transfer starts in H6. During H6, the MCF5206e drives the row address on the A[27:9], drives $\overline{\text{DRAMW}}$ high indicating a DRAM-read transfer, drives $\text{SIZ}[1:0]$ to \$1 indicating a byte transfer, and asserts $\overline{\text{TS}}$.

Clock L6

The MCF5206e asserts $\overline{\text{RAS}}$ to indicate the row address is valid on the address bus.

Clock H7

The MCF5206e negates $\overline{\text{TS}}$ and drives the column address on the address bus.

Clock L7

The MCF5206e asserts $\overline{\text{CAS}}[0]$ to indicate the column address is valid on the address bus. At this point, the DRAM turns on its output drivers and begins driving data on D[31:24].

Clock H8

The internal transfer acknowledge asserts to indicate that the current transfer will be completed and the data on the D[31:24] will be registered on the next rising edge of CLK.

Clock H9

The MCF5206e registers the read data driven by the DRAM and negates the internal transfer acknowledge, $\overline{\text{RAS}}$ and $\overline{\text{CAS}}[0]$, ending the first byte-read transfer. This begins the $\overline{\text{RAS}}$ precharge. Once $\overline{\text{CAS}}[0]$ is negated, the DRAM disables its output drivers, and the data bus is three-stated.

11.3.3.2 BURST TRANSFER IN NORMAL MODE. A burst transfer to DRAM is generated when the operand size is larger than the DRAM bank port size (e.g., line transfer to a 32-bit port, longword transfer to an 8-bit port). On all DRAM transfers, the

MCF5206e asserts \overline{TS} only once. The start of the secondary transfers of a burst is delayed by the DRAMC until the programmed RAS precharge time is reached.

The timing of burst reads and burst writes is identical in normal page mode, with the exception of when the DRAM drives data on reads and when the MCF5206e drives data on writes.

The fastest possible burst transfer in normal mode requires 3 clocks for the first transfer of the burst and 4 clocks for the secondary transfers (including a 1.5 clock \overline{RAS} precharge time). You can program the DCTR to generate slower normal mode transfers.

Figure 11-6 shows the timing of a burst longword write transfer to a 16-bit port in normal mode.

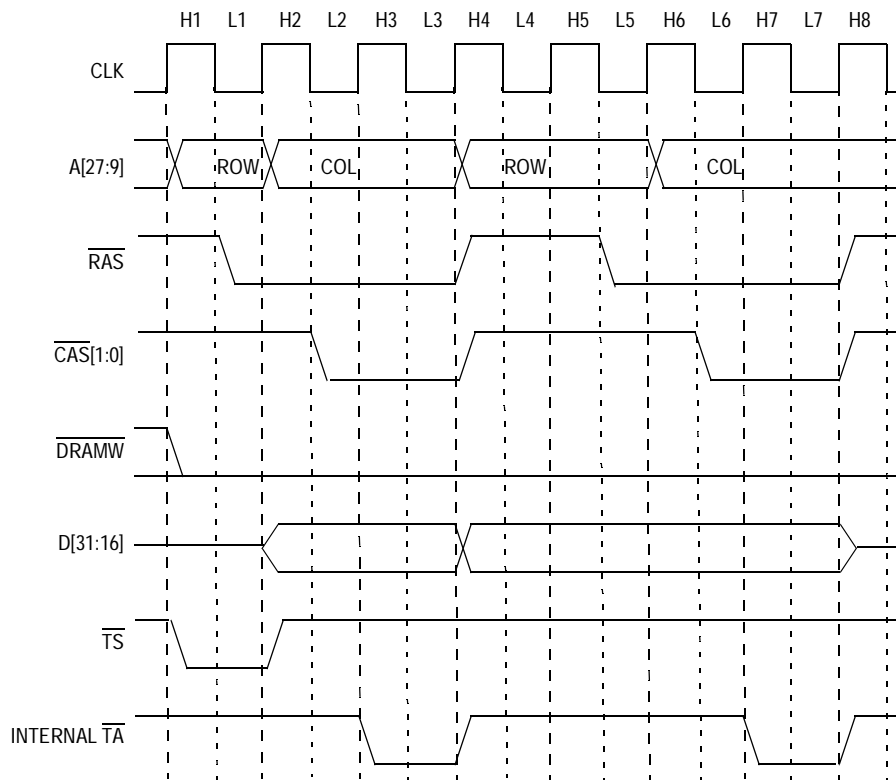

Figure 11-6. Longword Write Transfer in Normal Mode with 16-bit DRAM

Clock H1

The first DRAM write transfer of the burst starts in H1. During H1, the MCF5206e drives the row address on A[27:9], drives \overline{DRAMW} low indicating a DRAM write transfer, drives SIZ[1:0] to \$0 indicating a longword transfer, and asserts \overline{TS} . The address driven on the A[27:9] corresponds to the DRAM row address for the first transfer of the burst.

Clock L1

The MCF5206e asserts \overline{RAS} to indicate the row address is valid on A[27:9].

Clock H2

The MCF5206e negates \overline{TS} , drives the column address on A[27:9], and begins driving the data on D[31:16] for the first word write of the longword burst.

Clock L2

The MCF5206e asserts $\overline{CAS}[1:0]$ to indicate the column address is valid on the A[27:9].

Clock H3

The internal transfer acknowledge asserts to indicate the first word transfer of the longword burst will be completed on the next rising edge of CLK.

Clock H4

The MCF5206e negates the internal transfer acknowledge, \overline{RAS} and $\overline{CAS}[1:0]$, ending the first word write transfer of the longword burst. This begins the \overline{RAS} precharge. The MCF5206e drives the row address on A[27:9], and begins driving the data on D[31:16] for the second word write of the longword burst.

Clock L4/H5

The MCF5206e continues to negate \overline{RAS} to meet the precharge time.

Clock L5

After the \overline{RAS} precharge time is reached, the MCF5206e asserts \overline{RAS} to indicate the row address is valid on A[27:9].

Clock H6

The MCF5206e drives the column address on A[27:9].

Clock L6

The MCF5206e asserts $\overline{CAS}[1:0]$ to indicate the column address is valid on A[27:9].

Clock H7

The internal transfer acknowledge asserts to indicate the first word transfer of the longword burst will be completed on the next rising edge of CLK.

Clock H8

The MCF5206e negates the internal transfer acknowledge, \overline{RAS} and $\overline{CAS}[1:0]$, ending the second word write transfer of the longword burst. This begins the \overline{RAS} precharge. When the burst write is completed, D[31:0] is three-stated.

11.3.4 Fast Page Mode Operation

Fast page mode operation allows faster successive transfers to locations in DRAM that have the same row address. All locations with the same row address are said to be on the same “page.” Successive transfers that have the same row address as the initial transfer are called “page hits,” while successive transfers with different row addresses are called “page misses.”

On the initial transfer to a page, the DRAMC stores the row address. The address of a successive transfer is compared with the stored row address to determine if the transfer is a page hit or a page miss. For a page size of 512 Bytes (BPS=\$0 in the DCTR), bits 31-9 of the transfer address must match the corresponding bits stored as the active row address to be a page hit. For a page size of 1 KByte (BPS=\$1), bits 31-10 of the transfer address must match the corresponding bits of the active row address to be a page hit. For a page size of 2 KBytes (BPS=\$2), bits 31-11 of the transfer address must match the corresponding bits of the active row address to be a page hit.

Fast page mode transfers are facilitated by having the $\overline{\text{RAS}}$ signal remain asserted while asserting $\overline{\text{CAS}}$ to access successive column locations determined by the column address. Once $\overline{\text{RAS}}$ asserts on a transfer to a page, the page is said to be “open” and $\overline{\text{RAS}}$ remains asserted on all successive transfers to that page. If a transfer to a location in the current DRAM bank is a page hit, only the column address is driven and $\overline{\text{CAS}}$ asserted.

In fast page mode, $\overline{\text{RAS}}$ negates (precharge), “closing” the current page, under the following conditions:

1. A transfer occurs to an address in the current DRAM bank that is a page miss
2. A transfer occurs to an address in the other DRAM bank
3. The MCF5206e loses bus mastership
4. A refresh cycle is pending

In each of these cases, the $\overline{\text{RAS}}$ negates and the DRAMC does not allow an access to that bank until the $\overline{\text{RAS}}$ precharge time is met.

11.3.4.1 BURST TRANSFER IN FAST PAGE MODE. A burst transfer to DRAM is generated when the operand size is larger than the DRAM bank port size (e.g., line transfer to a 32-bit port, longword transfer to an 8-bit port). Burst transfers can access from two to 16 segments of data in a single transfer. On all DRAM transfers the MCF5206e asserts $\overline{\text{TS}}$ only once. The internal $\overline{\text{TA}}$ is asserted to indicate the transfer of each segment of data. The start of the secondary transfers of a burst are delayed by the DRAMC until the programmed $\overline{\text{RAS}}$ precharge time is reached.

The timing of burst reads and burst writes is identical in fast page mode, with the exception of when the DRAM drives data on reads and when the MCF5206e drives data on writes.

The fastest possible burst transfer in normal mode takes 3 clocks for the initial transfer, 2 clocks for secondary transfers with a 0.5 clock $\overline{\text{CAS}}$ precharge time and a 1.5 clock $\overline{\text{RAS}}$ precharge time. You can program the DCTR to generate slower fast page mode transfers.

Figure 11-7 shows the timing of a word write

Clock H3

The internal transfer acknowledge asserts to indicate that the first byte transfer of the word burst will be completed on the next rising edge of CLK.

Clock H4

The MCF5206e negates the internal transfer acknowledge, and $\overline{\text{CAS}}[0]$ ending the first byte write transfer of the word burst. At this point, the new page has been opened; therefore, the MCF5206e continues to assert $\overline{\text{RAS}}$. The negation of $\overline{\text{CAS}}[0]$ begins the $\overline{\text{CAS}}$ precharge. The MCF5206e drives the next column address on A[27:9] and the next data is driven on D[31:24].

Clock L4

The MCF5206e asserts $\overline{\text{CAS}}[0]$ to indicate the column address is valid on A[27:9].

Clock H5

The internal transfer acknowledge asserts to indicate that the first byte transfer of the word burst will be completed on the next rising edge of CLK.

Clock H6

The MCF5206e negates the internal transfer acknowledge and $\overline{\text{CAS}}[0]$ ending the final byte write of the word burst. Because the bank is in fast page mode, MCF5206e continues to assert $\overline{\text{RAS}}$. The negation of $\overline{\text{CAS}}[0]$ begins the $\overline{\text{CAS}}$ precharge. When the burst write is completed, the MCF5206e three-states D[31:0].

11.3.4.2 PAGE HIT READ TRANSFER IN FAST PAGE MODE.

A read transfer to an open page results in a page-hit read. The timing of page-hit reads differs from the timing of page-hit writes (page-hit writes are described in **Section 11.3.4.3 Page-Hit Write Transfer in Fast Page Mode**). The start of a page-hit read transfer to a DRAM bank in fast page mode can be delayed by the DRAMC until the programmed $\overline{\text{CAS}}$ precharge time is reached.

The fastest possible nonburst page-hit read transfer in fast page mode takes 2 clocks with a 0.5 clock $\overline{\text{CAS}}$ precharge time. The fastest possible burst page-hit read transfer in fast page mode takes 2 clocks for the initial transfer, and 2 clocks for all secondary reads with a 0.5 clock $\overline{\text{CAS}}$ precharge time. You can program the DCTR to generate slower fast page mode transfers.

Figure 11-8 shows the timing of a nonburst read opening a page and a subsequent page-hit read being generated. The first transfer that opens the page is a longword read transfer from a 32-bit port in fast page mode. The first read transfer is followed by a second page-hit longword read transfer. The timing of a page-hit read transfer is the same regardless of whether the page was opened by a burst read, burst write, nonburst read, or nonburst write transfer.

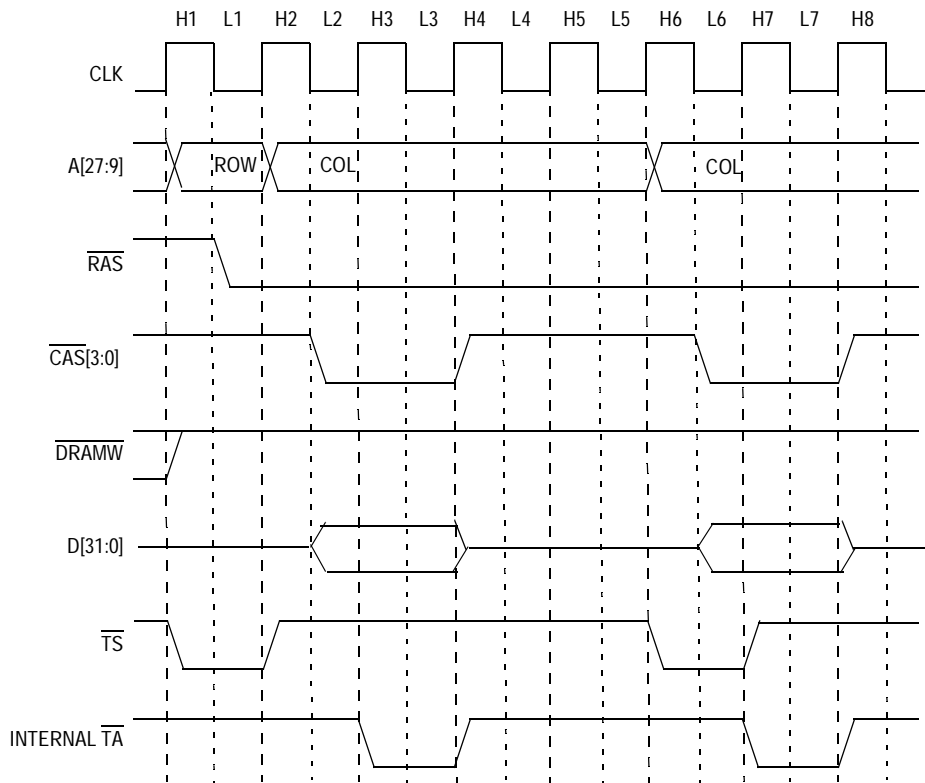

Figure 11-8. Longword Read Transfer Followed by a Page Hit Longword Read Transfer in Fast Page Mode with 32-Bit DRAM

Clock H1

The longword read transfer starts in H1. During H1, the MCF5206e drives the row address on A[27:9], drives $\overline{\text{DRAMW}}$ high indicating a DRAM read transfer, drives SIZ[1:0] to \$0 indicating a longword transfer, and asserts $\overline{\text{TS}}$.

Clock L1

The MCF5206e asserts $\overline{\text{RAS}}$ to indicate the row address is valid on A[27:9].

Clock H2

The MCF5206e negates $\overline{\text{TS}}$, and drives the column address on A[27:9].

Clock L2

The MCF5206e asserts $\overline{\text{CAS}}[3:0]$ to indicate the column address is valid on A[27:9]. At this point the DRAM turns on its output drivers and drives data on D[31:0].

Clock H3

The internal transfer acknowledge asserts to indicate that the longword read transfer will be completed and that data on D[31:0] will be registered on the next rising edge of CLK.

Clock H4

The MCF5206e negates the internal transfer acknowledge and $\overline{\text{CAS}}[3:0]$, ending the longword read transfer. At this point the new page has been opened; therefore, the MCF5206e continues to assert RAS. Once $\overline{\text{CAS}}[3:0]$ are negated the DRAM three-states D[31:0]. The negation of $\overline{\text{CAS}}[3:0]$ begins the $\overline{\text{CAS}}$ precharge.

Clock H6

Clock H6 is the earliest the next transfer initiated by the ColdFire core can start. In this case, a page-hit longword read is shown. The page-hit longword read transfer starts in H6. During H6, the MCF5206e drives the column address on A[27:9], drives $\overline{\text{DRAMW}}$ high indicating a DRAM read transfer, drives SIZ[1:0] to \$0 indicating a longword transfer, and asserts $\overline{\text{TS}}$.

Clock L6

The MCF5206e asserts $\overline{\text{CAS}}[3:0]$ to indicate the column address is valid on A[27:9]. At this point, the DRAM drives data on D[31:0].

Clock H7

The internal transfer acknowledge asserts to indicate that the longword read transfer will be completed and that data on D[31:0] will be registered on the next rising edge of CLK.

Clock H8

The MCF5206e negates the internal transfer acknowledge and $\overline{\text{CAS}}[3:0]$, ending the page-hit longword read transfer. Since the DRAM bank is in Fast Page Mode, the MCF5206e continues to assert RAS. Once $\overline{\text{CAS}}[3:0]$ are negated the DRAM three-states D[31:0]. The negation of $\overline{\text{CAS}}[3:0]$ begins the $\overline{\text{CAS}}$ precharge.

11.3.4.3 PAGE-HIT WRITE TRANSFER IN FAST PAGE MODE. A write transfer to an open page results in a page-hit write. The timing of page-hit write transfers differs from the timing of page-hit read transfers. On a page-hit write transfer, $\overline{\text{CAS}}$ is asserted one cycle later than in a page-hit read transfer. This difference is due to the write data not being driven until the cycle after $\overline{\text{TS}}$ is asserted while data must be set up prior to $\overline{\text{CAS}}$ assertion. The start of a page-hit write transfer to a DRAM bank in fast page mode can be delayed by the DRAMC until the programmed $\overline{\text{CAS}}$ precharge time is reached.

The fastest possible nonburst page-hit write transfer in fast page mode requires 3 clocks. The fastest possible burst page-hit write transfer in fast page mode requires 3 clocks for the initial transfer and 2 clocks for all secondary writes. You can program the DCTR to generate slower fast page mode transfers.

Figure 11-9 shows the timing of a page being opened by a word write transfer to a 16-bit port in Fast Page Mode. The first word write transfer is followed by a page-hit word write transfer. The timing of the page-hit write transfer is the same regardless of whether the page was opened by a burst read, burst write, nonburst read, or nonburst write transfer.

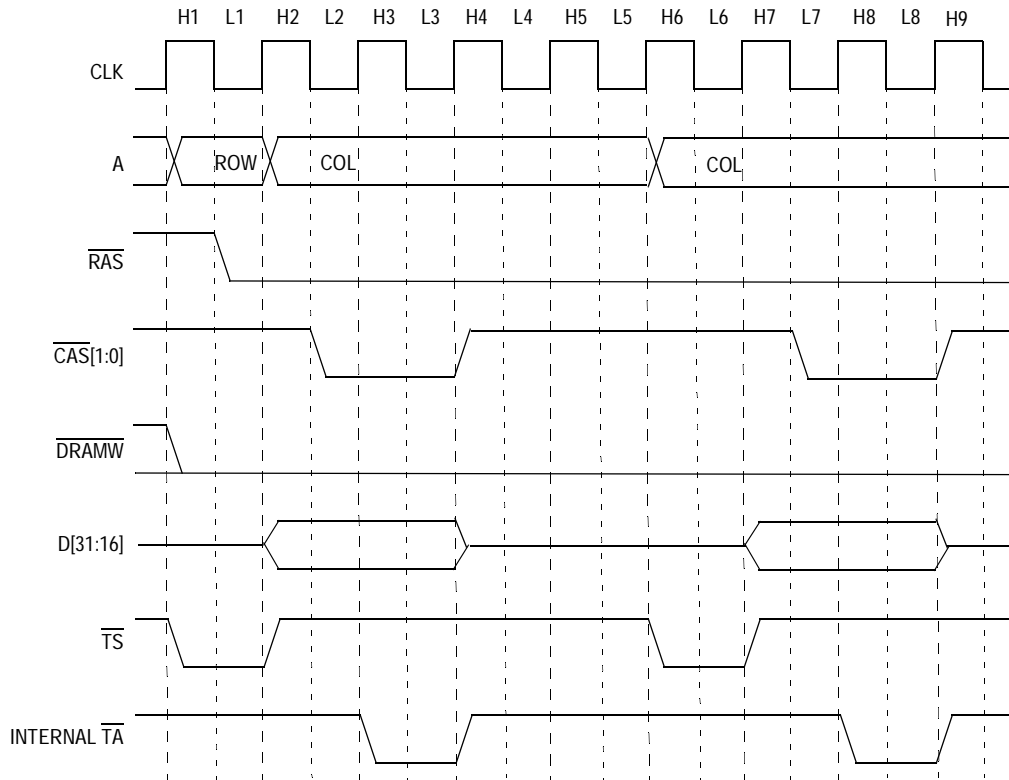

Figure 11-9. Word Write Transfer Followed by a Page-Hit Word Write Transfer in Fast Page Mode with 16-bit DRAM

Clock H1

The first word write transfer starts in H1. During H1, the MCF5206e drives the row address on A[27:9], drives $\overline{\text{DRAMW}}$ low indicating a DRAM write transfer, drives SIZ[1:0] to \$2 indicating a word transfer, and asserts $\overline{\text{TS}}$.

Clock L1

The MCF5206e asserts $\overline{\text{RAS}}$ to indicate the row address is valid on A[27:9].

Clock H2

The MCF5206e negates $\overline{\text{TS}}$, drives the column address on A[27:9], and begins driving the data on D[31:16].

Clock L2

The MCF5206e asserts $\overline{\text{CAS}}[1:0]$ to indicate the column address is valid on A[27:9].

Clock H3

The internal transfer acknowledge asserts to indicate that the word write transfer will be completed on the next rising edge of CLK.

Clock H4

The MCF5206e negates the internal transfer acknowledge and $\overline{\text{CAS}}[1:0]$, ending the first word write transfer. At this point, the new page has been opened; therefore, the MCF5206e continues to assert $\overline{\text{RAS}}$. The negation of $\overline{\text{CAS}}[1:0]$ begins the $\overline{\text{CAS}}$ precharge. When the write is completed, the MCF5206e three-states D[31:0].

Clock H6

Clock H6 is the earliest the next transfer initiated by the ColdFire core can start. In this case, a page-hit word write transfer is shown. The word write transfer starts in H6. During H6, the MCF5206e drives the column address on A[27:9], drives $\overline{\text{DRAMW}}$ low indicating a DRAM write transfer, drives $\text{SIZ}[1:0]$ to \$2 indicating a word transfer, and asserts $\overline{\text{TS}}$.

Clock H7

The MCF5206e negates $\overline{\text{TS}}$, drives the column address on A[27:9], and begins driving the data on D[31:16].

Clock L7

The MCF5206e asserts $\overline{\text{CAS}}[1:0]$ to indicate the column address is valid on A[27:9].

Clock H8

The internal transfer acknowledge asserts to indicate that the word write transfer will be completed on the next rising edge of CLK.

Clock H9

The MCF5206e negates the internal transfer acknowledge and $\overline{\text{CAS}}[1:0]$, ending the second word write transfer. Because the DRAM bank is in fast page mode, the MCF5206e continues to assert $\overline{\text{RAS}}$. The negation of $\overline{\text{CAS}}[1:0]$ begins the $\overline{\text{CAS}}$ precharge. When the write is completed, the MCF5206e three-states D[31:0].

11.3.4.4 PAGE MISS TRANSFER IN FAST PAGE MODE.

There is a potential performance penalty when using fast page mode. If a DRAM transfer misses the open page, the start of the transfer will be delayed while $\overline{\text{RAS}}$ precharges. Therefore, fast page mode can increase performance when many successive transfers hit

in the same page, but can also decrease performance when successive transfers hit in different pages.

In cases where a page is open in one bank and a transfer hits in the other bank, the transfer is not delayed because the second bank has already been precharged.

The fastest possible page miss transfer in fast page mode requires 4 clocks. The total number of clocks in a page miss transfer is the RAS precharge time, which causes the start of the transfer to be delayed (1 cycle for the fastest page miss transfer), plus the length of a fast page mode transfer to a new page (3 cycles for the fastest page miss transfer).

Figure 11-10 shows the timing of a page miss transfer in fast page mode. In this example, a page is opened by a byte read transfer to an 8-bit port. Then a second byte read transfer starts internally which misses the open page. Therefore, RAS must be precharged and a new page must be opened. The timing of the page-miss write transfer is the same as the timing of a page-miss read transfer.

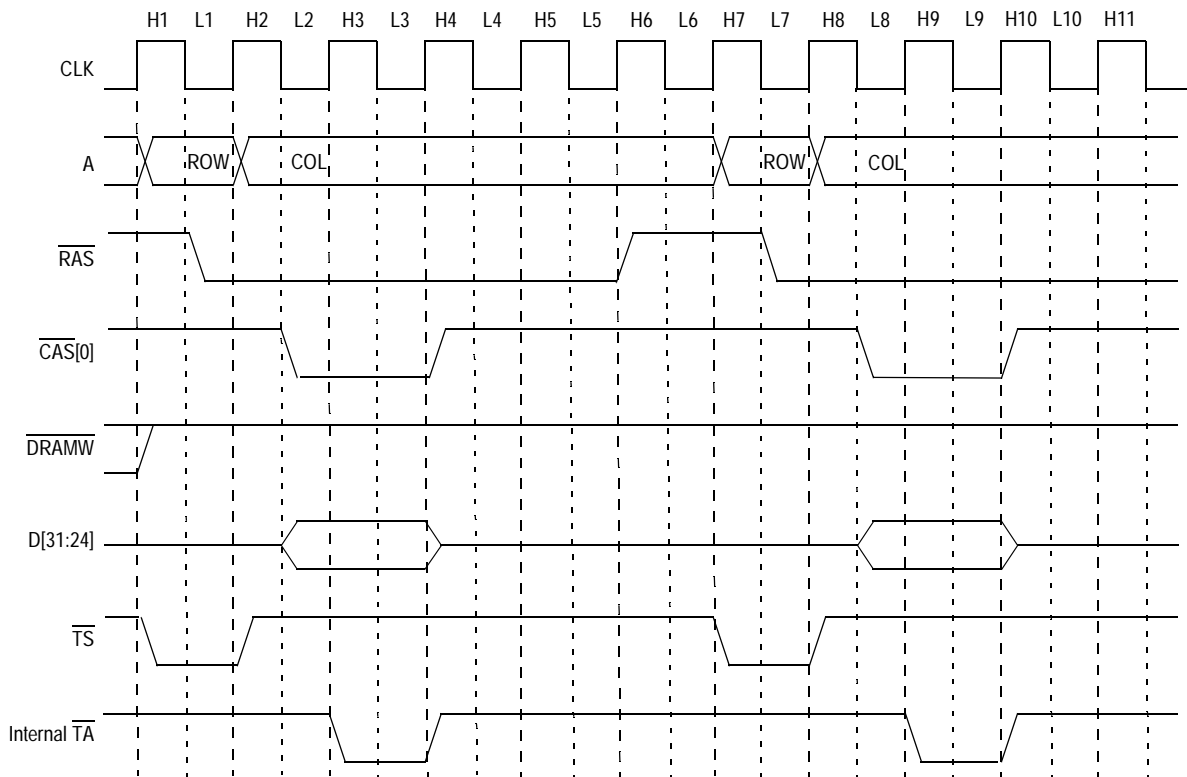

Figure 11-10. Byte Read Transfer Followed by a Page-Miss Byte Read Transfer in Fast Page Mode with 8-Bit DRAM

Clock H1

The first DRAM read transfer starts in H1. During H1, the MCF5206e drives the row address on A[27:9], drives $\overline{\text{DRAMW}}$ high indicating a DRAM read transfer, drives SIZ[1:0] to \$1 indicating a byte transfer, and asserts $\overline{\text{TS}}$.

Clock L1

The MCF5206e asserts $\overline{\text{RAS}}$ to indicate the row address is valid on A[27:9].

Clock H2

The MCF5206e negates $\overline{\text{TS}}$, and drives the column address on A[27:9].

Clock L2

The MCF5206e asserts $\overline{\text{CAS}}[0]$ to indicate the column address is valid on A[27:9]. At this point the DRAM drives data on D[31:24].

Clock H3

The internal transfer acknowledge asserts to indicate that the byte read transfer will be completed and data on D[31:24] will be registered on the next rising edge of CLK.

Clock H4

The MCF5206e negates the internal transfer acknowledge and $\overline{\text{CAS}}[0]$, ending the first byte read transfer. At this point, the new page has been opened; therefore, the MCF5206e continues to assert $\overline{\text{RAS}}$. Once $\overline{\text{CAS}}[0]$ is negated, the DRAM disables its output drivers and D[31:0] is three-stated. The negation of $\overline{\text{CAS}}[0]$ begins the CAS precharge.

Clock H5/L5

A byte read transfer to the same DRAM bank is generated internally by the ColdFire core. This transfer misses the open page.

Clock H6

The ColdFire core initiated a DRAM transfer on the previous cycle that misses the open page. Therefore, the MCF5206e negates RAS, beginning the RAS precharge. Once the RAS precharge time has been reached, a transfer to a new page can start.

Clock H7

The byte read transfer to a new page starts in H7. During H7, the MCF5206e drives the row address on A[27:9], drives $\overline{\text{DRAMW}}$ high indicating a DRAM read transfer, drives SIZ[1:0] to \$1 indicating a byte transfer, and asserts $\overline{\text{TS}}$.

Clock L7

The $\overline{\text{RAS}}$ precharge time has been met, so the MCF5206e asserts $\overline{\text{RAS}}$ to indicate the row address is valid on A[27:9].

Clock H8

The MCF5206e negates $\overline{\text{TS}}$, and drives the column address on A[27:9].

Clock L8

The MCF5206e asserts $\overline{\text{CAS}}[0]$ to indicate the column address is valid on A[27:9]. At this point the DRAM drives data on D[31:24].

Clock H9

The internal transfer acknowledge asserts to indicate that the byte read transfer will be completed and data on D[31:24] will be registered on the next rising edge of CLK.

Clock H10

The MCF5206e negates the internal transfer acknowledge and $\overline{\text{CAS}}[0]$, ending the first byte read transfer. At this point, the new page has been opened; therefore, the MCF5206e continues to assert $\overline{\text{RAS}}$. Once $\overline{\text{CAS}}[0]$ is negated, the DRAM disables its output drivers and D[31:0] is three-stated. The negation of $\overline{\text{CAS}}[0]$ begins the $\overline{\text{CAS}}$ precharge.

11.3.4.5 BUS ARBITRATION. If the MCF5206e loses bus mastership while a page is open ($\overline{\text{RAS}}$ is asserted), $\overline{\text{RAS}}$ is precharged. The $\overline{\text{RAS}}$ precharge timing depends on whether an active fast page mode DRAM transfer is in progress, whether a non-DRAM transfer is in progress, or whether the external bus is idle.

If the BL bit in the SIMR is cleared and $\overline{\text{BG}}$ is negated while an active fast page mode DRAM transfer is in progress, $\overline{\text{BD}}$ remains asserted until the transfer is complete. Once the DRAM transfer completes, the MCF5206e negates $\overline{\text{BD}}$ and begins precharging $\overline{\text{RAS}}$.

In the case where the BL bit in the SIMR is cleared and $\overline{\text{BG}}$ is negated while a nonDRAM transfer is in progress and a page is open, the MCF5206e begins precharging $\overline{\text{RAS}}$ on the cycle following the negation of $\overline{\text{BG}}$, even though $\overline{\text{BD}}$ remains asserted until the completion of the nonDRAM transfer.

If the BL bit in the SIMR is cleared and $\overline{\text{BG}}$ is negated while the external bus is idle and a page is open, the MCF5206e negates $\overline{\text{BD}}$ and begins precharging $\overline{\text{RAS}}$ on the cycle following the negation of $\overline{\text{BG}}$.

When the BL bit in the SIMR is set to 1 and $\overline{\text{BG}}$ is asserted, the bus is locked with the MCF5206e. If $\overline{\text{BG}}$ is negated while the bus is locked and a page is open, $\overline{\text{RAS}}$ and $\overline{\text{BD}}$ remains asserted, because the MCF5206e maintains bus mastership regardless of $\overline{\text{BG}}$ when the bus is locked.

NOTE

Fast page mode is not supported for external master DRAM transfers. A DRAM bank programmed for fast page mode, operates in fast page mode for ColdFire core initiated transfers, but operates in burst page mode for external master initiated transfers.

Figure 11-11 shows the effect of bus arbitration on the DRAM signals when the external bus is idle and a page is open in fast page mode.

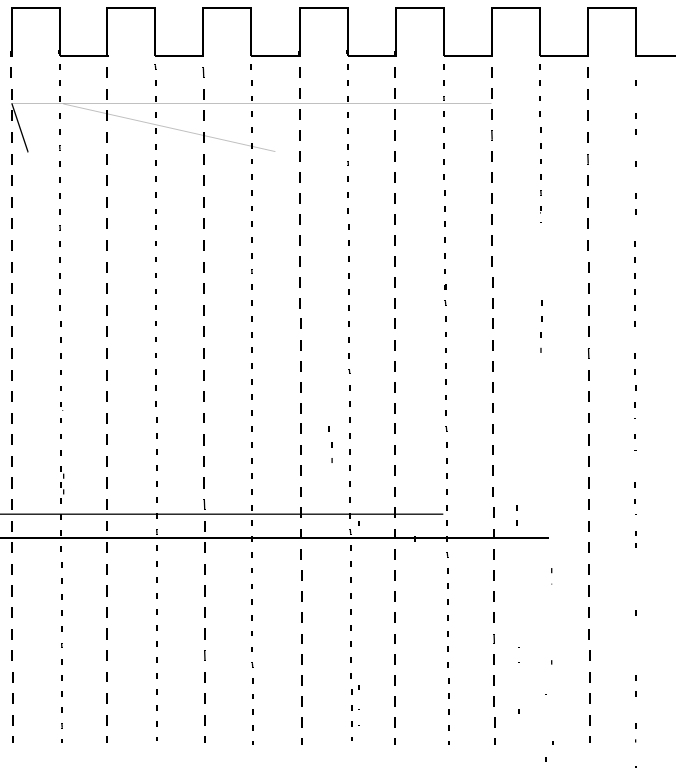

Figure 11-11. Bus Arbitration in Fast Page Mode

Clock H1

A Fast Page Mode transfer starts in H1. During H1, the MCF5206e drives the row address on A[27:9], and asserts \overline{TS} .

Clock L1

The MCF5206e asserts \overline{RAS} to indicate the row address is valid on A[27:9].

Clock H2

The MCF5206e negates \overline{TS} , and drives the column address on A[27:9].

Clock L2

The MCF5206e asserts $\overline{\text{CAS}}$ to indicate the column address is valid on A[27:9].

Clock H3

The internal transfer acknowledge asserts to indicate that the current transfer will be completed on the next rising edge of CLK.

Clock H4

The MCF5206e negates the internal transfer acknowledge and $\overline{\text{CAS}}$, ending the transfer. At this point, a page has been opened; therefore, the MCF5206e continues to assert $\overline{\text{RAS}}$. The negation of $\overline{\text{CAS}}$ begins the $\overline{\text{CAS}}$ precharge.

Clock H6

After the bus has idled for two clocks, $\overline{\text{BG}}$ is negated (while the BL bit in the SIMR is cleared).

Clock H7

The MCF5206e then three-states the external bus signals, negates $\overline{\text{RAS}}$ (closing the page), and negates $\overline{\text{BD}}$, relinquishing mastership of the bus. The negation of $\overline{\text{RAS}}$ begins the $\overline{\text{RAS}}$ precharge.

11.3.5 Burst Page-Mode Operation

Burst page mode performs fast page mode transfers only for burst transfers. A burst transfer to DRAM occurs any time the operand size is larger than the DRAM bank port size (e.g., line transfer to a 32-bit port, longword transfer to an 8-bit port). After completing the burst, the MCF5206e negates $\overline{\text{RAS}}$, closing the page. Because all secondary transfers of a burst are guaranteed to be page hits, a page miss never occurs in burst page mode. Nonburst transfers occur as in normal mode. Therefore, burst page mode always provides the same or better performance than normal mode.

The timing of read and write transfers is identical in burst page mode, with the exception of when the DRAM drives data on reads and when the MCF5206e drives data on writes.

The fastest possible burst transfer in burst page mode requires three clocks for the first transfer and two clocks on the secondary transfers. The fastest possible nonburst transfer in burst page mode requires three clocks. You can program the DCTR to generate slower burst page mode transfers.

Figure 11-12 shows a longword write transfer followed by a word read transfer to a 16-bit port with burst page mode enabled for the bank. The burst longword write transfer is handled as in fast page mode with the initial word transfer of the burst taking three cycles and the secondary word transfer taking two cycles. However, in burst page mode, the MCF5206e precharges $\overline{\text{RAS}}$ once the burst transfer is complete. The second transfer (a word read) is executed as in normal mode as it is not a burst transfer.

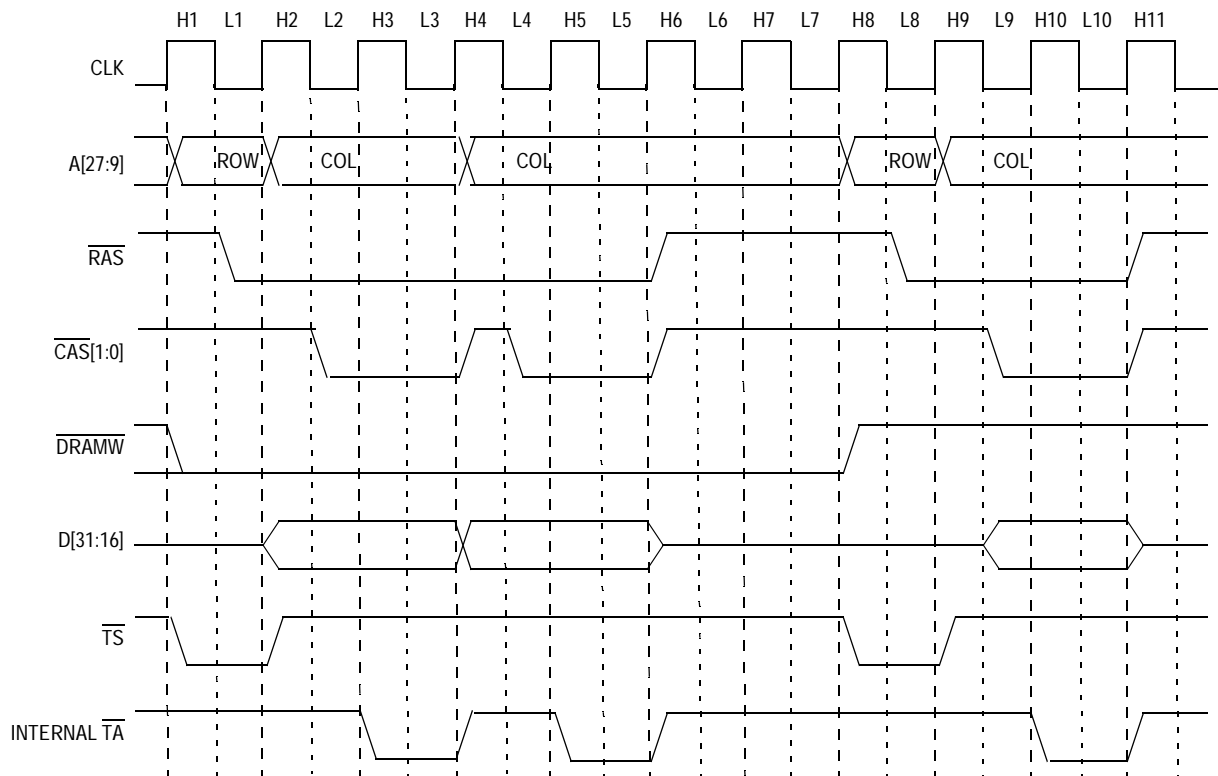

Figure 11-12. Longword Write Transfer Followed by a Word Read Transfer in Burst Page Mode with 16-Bit DRAM

Clock H1

The first word write transfer of the longword burst starts in H1. During H1, the MCF5206e drives the row address on A[27:9], drives $\overline{\text{DRAMW}}$ low indicating a DRAM write transfer, drives $\text{SIZ}[1:0]$ to \$0 indicating a longword transfer, and asserts $\overline{\text{TS}}$.

Clock L1

The MCF5206e asserts $\overline{\text{RAS}}$ to indicate the row address is valid on A[27:9].

Clock H2

The MCF5206e negates $\overline{\text{TS}}$, drives the column address on A[27:9], and begins driving the data on D[31:16].

Clock L2

The MCF5206e asserts $\overline{\text{CAS}}[1:0]$ to indicate the column address is valid on A[27:9].

Clock H3

The internal transfer acknowledge asserts to indicate that the first word transfer of the longword burst will be completed on the next rising edge of CLK.

Clock H4

The MCF5206e negates the internal transfer acknowledge, and $\overline{\text{CAS}}[1:0]$, ending the first word write transfer of the longword burst. At this point, the new page has been opened; therefore, the MCF5206e continues to assert $\overline{\text{RAS}}$. The negation of $\overline{\text{CAS}}[1:0]$ begins the CAS precharge. The MCF5206e drives the next column address on A[27:9] and the next data on D[31:16].

Clock L4

The MCF5206e asserts $\overline{\text{CAS}}[1:0]$ to indicate the column address is valid on A[27:9].

Clock H5

The internal transfer acknowledge asserts to indicate that the first word transfer of the longword burst will be completed on the next rising edge of CLK.

Clock H6

The MCF5206e negates the internal transfer acknowledge, $\overline{\text{RAS}}$, and $\overline{\text{CAS}}[1:0]$, ending the final write transfer of the longword burst. Because the bank is in burst page mode, MCF5206e precharges $\overline{\text{RAS}}$ at the end of the burst. The negation of $\overline{\text{RAS}}$ begins the RAS precharge. When the burst write is completed, the MCF5206e three-states D[31:0].

Clock H8

Clock H8 is the earliest the next transfer initiated by the ColdFire core can start. Because this next DRAM cycle is a nonburst word read transfer, it is handled as a normal mode transfer. During Clock H8, the MCF5206e drives the row address on A[27:9], drives $\overline{\text{DRAMW}}$ high indicating a DRAM read transfer, drives SIZ[1:0] to \$2 indicating a word transfer, and asserts $\overline{\text{TS}}$.

Clock L8

The MCF5206e asserts $\overline{\text{RAS}}$ to indicate the row address is valid on A[27:9].

Clock H9

The MCF5206e negates $\overline{\text{TS}}$, and drives the column address on A[27:9]

Clock L9

The MCF5206e asserts $\overline{\text{CAS}}[1:0]$ to indicate the column address is valid on A[27:9]. At this point the DRAM drives the data on D[31:16].

Clock H10

The internal transfer acknowledge asserts to indicate that the current transfer will be completed and the data on D[31:16] will be registered on the next rising edge of CLK.

Clock H11

The MCF5206e registers the read data driven by the DRAM, and negates the internal transfer acknowledge, $\overline{\text{RAS}}$ and $\overline{\text{CAS}}[1:0]$, ending the word read transfer. This begins the RAS precharge. Once CAS is negated, the DRAM disables its output drivers and D[31:0] is three-stated.

11.3.6 Extended Data-Out (EDO) DRAM Operation

Extended data-out (EDO) DRAMs do not three-state their output drivers at the negation of $\overline{\text{CAS}}$ on page read transfers as do fast-page-mode DRAMs. Instead, data remains valid until some time (typically 5 ns) after the next falling edge of $\overline{\text{CAS}}$. This allows $\overline{\text{CAS}}$ to be precharged without the output data going invalid. The result is that a system using slower, less expensive EDO DRAM can achieve the same performance as a system using faster, more expensive fast-page-mode DRAMs.

The MCF5206e supports EDO DRAM with a $\overline{\text{CAS}}$ timing that takes advantage of the read data remaining valid after $\overline{\text{CAS}}$ negates. To enable the EDO $\overline{\text{CAS}}$ timing for both DRAM banks, set the EDO Enable bit in the DCTR to 1. When set to 1, $\overline{\text{CAS}}$ negates one-half clock cycle earlier for fast-page-mode and burst-page-mode transfers than when the EDO Enable bit is cleared. At higher clock frequencies, the EDO $\overline{\text{CAS}}$ timing allows slower, less expensive EDO DRAMs to be used, since the $\overline{\text{CAS}}$ precharge starts before data is registered on read transfers. For the fastest timing in fast page mode or burst page mode, having the EDO Enable bit set gives one clock of $\overline{\text{CAS}}$ precharge time, rather than one-half of a clock with the EDO Enable bit cleared.

Since EDO DRAM continues to drive data after a read as long as $\overline{\text{RAS}}$ is asserted, be careful with the system design using EDO DRAM to ensure bus contention does not occur when a nonDRAM transfer occurs while a page is open in fast page mode.

NOTE

Failure to use normal mode or burst page mode with EDO DRAM without external circuitry to control the DRAM output drivers could result in damage to the MCF5206e and the system.

Figure 11-13 shows the timing of a word read in Fast Page Mode followed by a page miss word read using 8-bit wide EDO DRAM (the EDO bit in the DCTR is set).

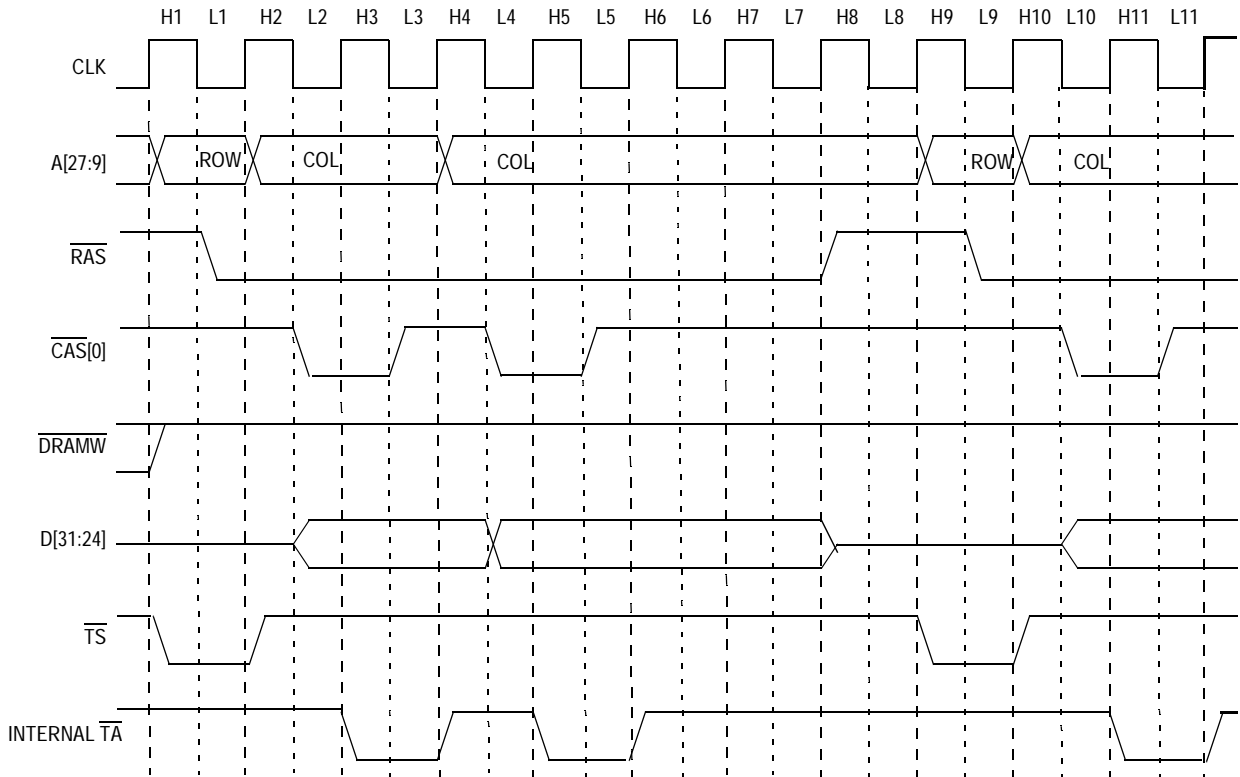

Figure 11-13. Word Read Transfer Followed by a Page Miss Byte Read Transfer in Fast Page Mode with 8-Bit EDO DRAM

Clock H1

The first byte read transfer of the burst word transfer starts in H1. During H1, the MCF5206e drives the row address on A[27:9], drives $\overline{\text{DRAMW}}$ high indicating a DRAM write transfer, drives SIZ[1:0] to \$2 indicating a byte transfer, and asserts $\overline{\text{TS}}$.

Clock L1

The MCF5206e asserts $\overline{\text{RAS}}$ to indicate the row address is valid on A[27:9].

Clock H2

The MCF5206e negates $\overline{\text{TS}}$, drives the column address on A[27:9].

Clock L2

The MCF5206e asserts $\overline{\text{CAS}}[0]$ to indicate the column address is valid on A[27:9]. At this point the EDO DRAM drives data on D[31:24].

Clock H3

The internal transfer acknowledge asserts to indicate that the first byte read transfer of the word burst will be completed and the data on D[31:24] will be registered on the next rising edge of CLK.

Clock L3

With EDO DRAM, data is driven continuously on a read after the falling edge of $\overline{\text{CAS}}$ until the next falling edge of $\overline{\text{CAS}}$ or until the rising edge of $\overline{\text{RAS}}$. This allows the MCF5206e to negate $\overline{\text{CAS}}[0]$ on L3 to allow more $\overline{\text{CAS}}$ precharge time. The negation of $\overline{\text{CAS}}[0]$ begins the $\overline{\text{CAS}}$ precharge.

Clock H4

The MCF5206e negates the internal transfer acknowledge, ending the first byte read transfer of the word burst. At this point, the new page has been opened; therefore, the MCF5206e continues to assert $\overline{\text{RAS}}$. The MCF5206e drives the next column address on A[27:9].

Clock L4

The MCF5206e asserts $\overline{\text{CAS}}[0]$ to indicate the column address is valid on A[27:9]. At this point, the EDO DRAM begins driving the data on D[31:24].

Clock H5

The internal transfer acknowledge asserts to indicate that the first byte read transfer of the word burst will be completed and the data on D[31:24] will be registered on the next rising edge of CLK.

Clock L5

With EDO DRAM, data is driven continuously on a read after the falling edge of $\overline{\text{CAS}}$ until the next falling edge of $\overline{\text{CAS}}$ or until the rising edge of $\overline{\text{RAS}}$. This allows the MCF5206e to negate $\overline{\text{CAS}}[0]$ on L3 to allow more $\overline{\text{CAS}}$ precharge time. The negation of $\overline{\text{CAS}}[0]$ begins the $\overline{\text{CAS}}$ precharge.

Clock H6

The MCF5206e negates the internal transfer acknowledge, ending the final byte read transfer of the word burst. Because the bank is in fast page mode, MCF5206e continues to assert $\overline{\text{RAS}}$. Because $\overline{\text{RAS}}$ remains asserted, the EDO DRAM continues to drive the data from the previous read transfer on D[31:24].

Clock H7/L7

A byte read transfer to the same DRAM bank is generated internally by the ColdFire core. This transfer misses the open page.

Clock H8

The ColdFire core initiated a DRAM transfer on the previous cycle that missed the open page. Therefore, the MCF5206e negates $\overline{\text{RAS}}$, beginning the $\overline{\text{RAS}}$ precharge. Once the $\overline{\text{RAS}}$ precharge time has been reached, a transfer to a new page can start. Once $\overline{\text{RAS}}$ is negated, the EDO DRAM disables its output drivers and D[31:0] is three-stated.

Clock H9

The byte read transfer to a new page starts in H9. During H9, the MCF5206e drives the row address on A[27:9], drives $\overline{\text{DRAMW}}$ high indicating a DRAM read transfer, drives SIZ[1:0] to \$1 indicating a byte transfer, and asserts $\overline{\text{TS}}$.

Clock L9

Now that the $\overline{\text{RAS}}$ precharge time has been reached, the MCF5206e asserts $\overline{\text{RAS}}$ is to indicate the row address is valid on A[27:9].

Clock H10

The MCF5206e negates $\overline{\text{TS}}$, drives the column address on A[27:9].

Clock L10

The MCF5206e asserts $\overline{\text{CAS}}[0]$ to indicate the column address is valid on A[27:9]. At this point the EDO DRAM drives data on D[31:24].

Clock H11

The internal transfer acknowledge asserts to indicate that the first byte read transfer of the word burst will be completed and the data on D[31:24] will be registered on the next rising edge of CLK.

Clock H12

The MCF5206e negates the internal transfer acknowledge, ending the byte-read transfer. Because the bank is in fast page mode, MCF5206e continues to assert $\overline{\text{RAS}}$. Because $\overline{\text{RAS}}$ remains asserted, the EDO DRAM continues to drive the data from the previous read transfer on D[31:24].

11.3.7 Refresh Operation

The DRAMC supports $\overline{\text{CAS}}$ -before- $\overline{\text{RAS}}$ refresh. Refresh cycles can be generated while nonDRAM transfers are actively using the external bus. Only transfers accessing the DRAM banks delays a refresh cycle. Both DRAM banks are refreshed on each refresh cycle.

The value stored in the RC field of the DCRR determines the rate at which the refresh controller internally requests refreshes in the DRAMC. The DRAMC does not immediately

initiate a refresh cycle if a DRAM transfer is occurring when the internal refresh request is made. The DRAMC waits until the active DRAM transfer is complete and then initiates the DRAM refresh cycle. Refresh cycles occur immediately after the internal refresh request is made during idle bus cycles and during nonDRAM transfers.

NOTE

Add margin when determining the value to program into the RC field of the DCRR so that a refresh cycle delayed by the longest possible DRAM transfer does not violate the refresh rate specified for the DRAMs being used.

Programming the RC field in the DCRR to \$000 causes internal refresh requests to occur at the slowest rate—once every 65,536 system clock cycles. Programming the RC field in the DCRR to \$001 causes internal refresh requests to occur at the fastest rate—once every 16 system clocks. If multiple refresh requests occur while waiting for a DRAM transfer to finish, only one refresh cycle is generated.

Writing to the DCRR causes an internal refresh request to occur and the refresh counter to be reloaded. If the DCRR is written while a refresh request is pending, only one refresh cycle is generated. If the DCRR is written while a refresh cycle is in progress, another refresh cycle is not generated after the one in progress completes.

The refresh period is the amount of time between internal refresh requests. The refresh period can be calculated from the value programmed in the RC field of the DCRR using the following equations:

For $RC > \$000$:

$$\text{Refresh period} = RC \times 16 \times (1/\text{system clock frequency})$$

For $RC = \$000$:

$$\text{Refresh period} = 65536 \times (1/\text{system clock frequency})$$

When the DRAMC initiates a refresh cycle, it delays any DRAM transfer initiated by the ColdFire core or by an external master until the RAS precharge is complete at the end of refresh cycle. If a DRAM transfer is initiated by the ColdFire core while a refresh cycle is in progress and the MCF5206e is not the bus master, bus request (\overline{BR}) is not asserted until after the refresh completes.

A master reset terminates any active refresh cycle and resets the refresh controller. Master reset is required on all power-on resets. During a master reset, refresh cycles do not occur; after a master reset, refreshes occur at the slowest rate (DCRR is initialized to \$0000).

NOTE

During a master reset, the DCCR is reset to \$000 (giving the slowest refresh rate) and the DCTR is reset to \$0000 (giving the fastest waveform timing). After a master reset, the initialization sequence should program the DRAMC Refresh Register (DCRR) and the DRAMC Timing Register (DCTR) such that refresh cycles are generated at the required rate and with the required timing for the DRAM in the system. In general, DRAMs require an initial pause after power-up and require a minimum number of DRAM cycles to be run before the DRAM is ready for use. This initialization sequence must be handled through software.

Normal reset does not affect a refresh cycle in progress and does not reset the refresh controller. Refreshes occur during a normal reset with the timing specified in the DCTR and at the rate specified in the DCRR.

11.3.8 External Master Use of the DRAM Controller

The DRAMC can support external master-initiated transfers. When an external master is the bus master, the MCF5206e registers all available address signals, $\overline{R/W}$, and $SIZ[1:0]$ on the rising edge of clock when \overline{TS} is asserted. Based on the address, direction, and data size, the DRAMC asserts \overline{RAS} , \overline{CAS} , \overline{DRAMW} , and conditionally drives the address bus.

NOTE

If you do not want the MCF5206e DRAMC to respond on external master transfers, \overline{TS} should not be asserted to the MCF5206e during external master transfers. However, the MCF5206e continues to generate DRAM refresh cycles while the bus is granted to an external master.

NOTE

The driving of the data on writes and the latching of data on reads based on the data size and port size of the DRAM is the responsibility of the external master. The MCF5206e does not drive the data bus when it is not master of the external bus.

The MCF5206e can delay the access to DRAM for an external master initiated transfer if a refresh request is pending or if the programmed \overline{RAS} precharge time has not been reached. If there is a refresh cycle in progress or if there is a refresh request pending when an external master starts a DRAM transfer, the MCF5206e does not start driving the row address and assert \overline{RAS} until the \overline{RAS} precharge time has been reached after completing the refresh cycle. If a refresh request occurs during an external master DRAM transfer, the refresh cycle is delayed until the external master DRAM transfer is completed. If the programmed \overline{RAS} precharge time from the previous DRAM transfer has not been

reached, the MCF5206e does not start driving the row address and assert $\overline{\text{RAS}}$ until the precharge time has been reached.

For external master DRAM transfers, the MCF5206e drives $\overline{\text{TA}}$ as an output. $\overline{\text{TA}}$ is asserted to signify the end of each transfer (or subtransfer in the case of a burst). The assertion of $\overline{\text{TA}}$ can be used for latching data on read transfers and can also be used by the external master to trigger the driving of new write data for successive transfers during bursts.

When using the MCF5206e to multiplex the address for external master DRAM transfers (DAEM bit in the DCTR is set), the external master must stop driving the address bus during the clock cycle after $\overline{\text{TS}}$ is asserted. This allows the MCF5206e to drive the row address and the column address on A[27:9] at the appropriate times. If the external master cannot three-state the address bus, the driving of the address by the MCF5206e should be disabled and the address multiplexing for external master transfers must be handled in the external system.

If address multiplexing for external master transfers is to be handled in the external system, the DRAMC must be configured to three-state the address bus during these transfers by clearing the DAEM bit in the DCTR. This does not affect the operation of $\overline{\text{TA}}$, $\overline{\text{RAS}}$, $\overline{\text{CAS}}$, or $\overline{\text{DRAMW}}$ during external master DRAM transfers.

NOTE

The MCF5206e does not drive the address for external master chip select or default memory transfers.

11.3.8.1 EXTERNAL MASTER NONBURST TRANSFER IN NORMAL MODE. An external master nonburst transfer to DRAM is generated when the operand size is the same or smaller than the DRAM port size (e.g., longword transfer to a 32-bit port or byte transfer to a 16-bit port). The external master must assert $\overline{\text{TS}}$ at the start of all non-burst transfers.

The timing of nonburst reads and nonburst writes is identical in normal page mode, with the exception of when the DRAM drives data on reads and when the external master drives data on writes.

The fastest possible nonburst transfer in normal mode requires 5 clocks. You can program the DCTR to generate slower normal mode transfers.

Figure 11-14 illustrates the timing of an external master DRAM byte read transfer followed by a byte write transfer to a 8-bit port in normal mode.

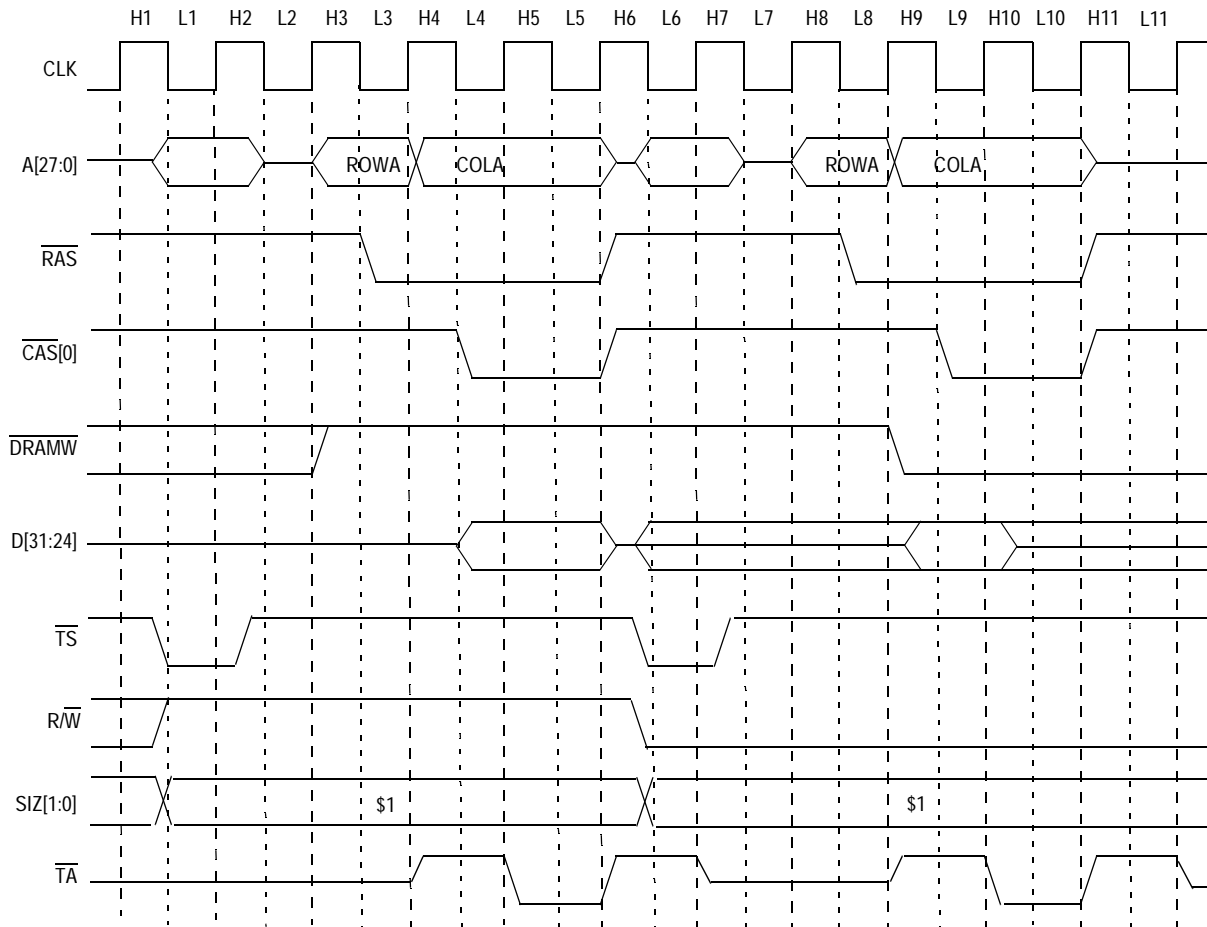

Figure 11-14. External Master Byte Read Transfer Followed by Byte Write Transfer in Normal Mode with 16-Bit DRAM

Clock H1/L1

An external master is the current bus master. The external master starts a DRAM transfer by driving A[27:0], driving R/W high indicating a read transfer, driving SIZ[1:0] to \$1 indicating a byte transfer, and asserting TS. These inputs to the MCF5206e must be set up with respect to the rising edge of CLK H2.

Clock H2

On the rising edge of CLK when TS is asserted, the MCF5206e registers the address and attribute signals. The MCF5206e internally decodes these signals and determine if the external master transfer is a DRAM access. The external master negates TS and must three-state A[27:0] after the rising edge of CLK H2, if the internal address multiplexing is to be used.

Clock H3

The MCF5206e has determined that the external master transfer is a DRAM access, so the MCF5206e drives A[27:0] with the same value as was registered on the rising edge of H2. A[27:9] contains the DRAM row address. The MCF5206e also drives DRAMW high, indicating a DRAM read cycle.

Clock L3

The MCF5206e asserts $\overline{\text{RAS}}$ to indicate the row address is valid on A[27:9].

Clock H4

The MCF5206e internally multiplexes the address and drives out the column address on A[27:9]. The MCF5206e also actively drives $\overline{\text{TA}}$ negated.

Clock L4

The MCF5206e asserts $\overline{\text{CAS}}[0]$ to indicate the column address is valid on A[27:9]. At this point the DRAM drives the data on D[31:24].

Clock H5

The MCF5206e asserts the $\overline{\text{TA}}$ signal to indicate that the byte read transfer will be completed and the read data will be valid on D[31:24] on the next rising edge of CLK.

Clock H6

The MCF5206e then negates $\overline{\text{RAS}}$, $\overline{\text{CAS}}[0]$, and $\overline{\text{TA}}$ and three-states A[27:0], ending the byte-read transfer. The negation of RAS starts the RAS precharge. Once A[27:0] has three-stated, the external master can start another transfer. In this case, the external master starts a DRAM byte write transfer immediately by driving A[27:0], driving R/W low indicating a write transfer, driving SIZ[1:0] to \$1 indicating a byte transfer, and asserting $\overline{\text{TS}}$. The external master must drive the data in the correct byte lanes based on the data size and the port size of the DRAM, and must drive the data to meet the timing specifications of the DRAM. In this case, the external master should drive the write data on D[31:24].

Clock H7

The MCF5206e three-states $\overline{\text{TA}}$. On the rising edge of CLK where $\overline{\text{TS}}$ is asserted, the MCF5206e registers the address and attribute signals. The MCF5206e internally decodes these signals and determines if the external master transfer is a DRAM access. The external master must three-state A[27:0] after the rising edge of CLK H2, if the internal address multiplexing is to be used.

Clock H8

The MCF5206e has determined that the external master transfer is a DRAM access, so the MCF5206e drives the A[27:0] with the same value as was registered on the rising edge of H2. A[27:9] contains the row address for the DRAM. The MCF5206e also drives DRAMW low, indicating a DRAM write cycle.

Clock L8

The MCF5206e asserts \overline{RAS} to indicate the row address is valid on A[27:9].

Clock H9

The MCF5206e internally multiplexes the address and drives out the column address on A[27:9]. The MCF5206e also actively drives \overline{TA} negated.

Clock L9

The MCF5206e asserts $\overline{CAS}[0]$ to indicate the column address is valid on A[27:9]. The external master must set up and hold the data with respect to the falling edge of $\overline{CAS}[0]$ based on the DRAM specifications.

Clock H10

The MCF5206e asserts the \overline{TA} signal to indicate that the byte write transfer will be completed on the next rising edge of CLK.

Clock H11

The MCF5206e then negates \overline{RAS} , $\overline{CAS}[0]$, and \overline{TA} , and three-state the address bus, ending the byte write transfer. The negation of \overline{RAS} starts the \overline{RAS} precharge. Once A[27:0] has three-stated, the external master can start another transfer.

Clock H12

The MCF5206e three-states \overline{TA} .

11.3.8.2 EXTERNAL MASTER BURST TRANSFER IN NORMAL MODE. A burst transfer to DRAM is generated when the operand size is larger than the DRAM bank port size (e.g., line transfer to a 32-bit port, longword transfer to an 8-bit port). On DRAM burst transfers, the external master should assert \overline{TS} only once. The start of the secondary transfers of a burst is delayed by the DRAMC until the programmed \overline{RAS} precharge time is met.

The timing of external master burst reads and burst writes is identical in normal page mode, with the exception of when the DRAM drives data on reads and when the external master drives data on writes.

The fastest possible external master burst transfer in normal mode requires 5 clocks for the first transfer of the burst and 4 clocks for the secondary transfers (including a 1.5 clock $\overline{\text{RAS}}$ precharge time). You can program the DCTR to generate slower normal mode transfers.

Figure 11-15 illustrates the timing of a external master longword write transfer to a 16-bit DRAM in normal mode. The timing of the first transfer of the burst operates the same as the nonburst case. After the first transfer of the burst completes, $\overline{\text{TA}}$ is negated and the row address is driven again by the MCF5206e. The MCF5206e asserts $\overline{\text{RAS}}$ after the $\overline{\text{RAS}}$ precharge time is met and the transfer completes the same as in the nonburst case. Driving the write data in the correct byte lanes at the proper time to meet the specifications of the DRAM is the responsibility of the external master.

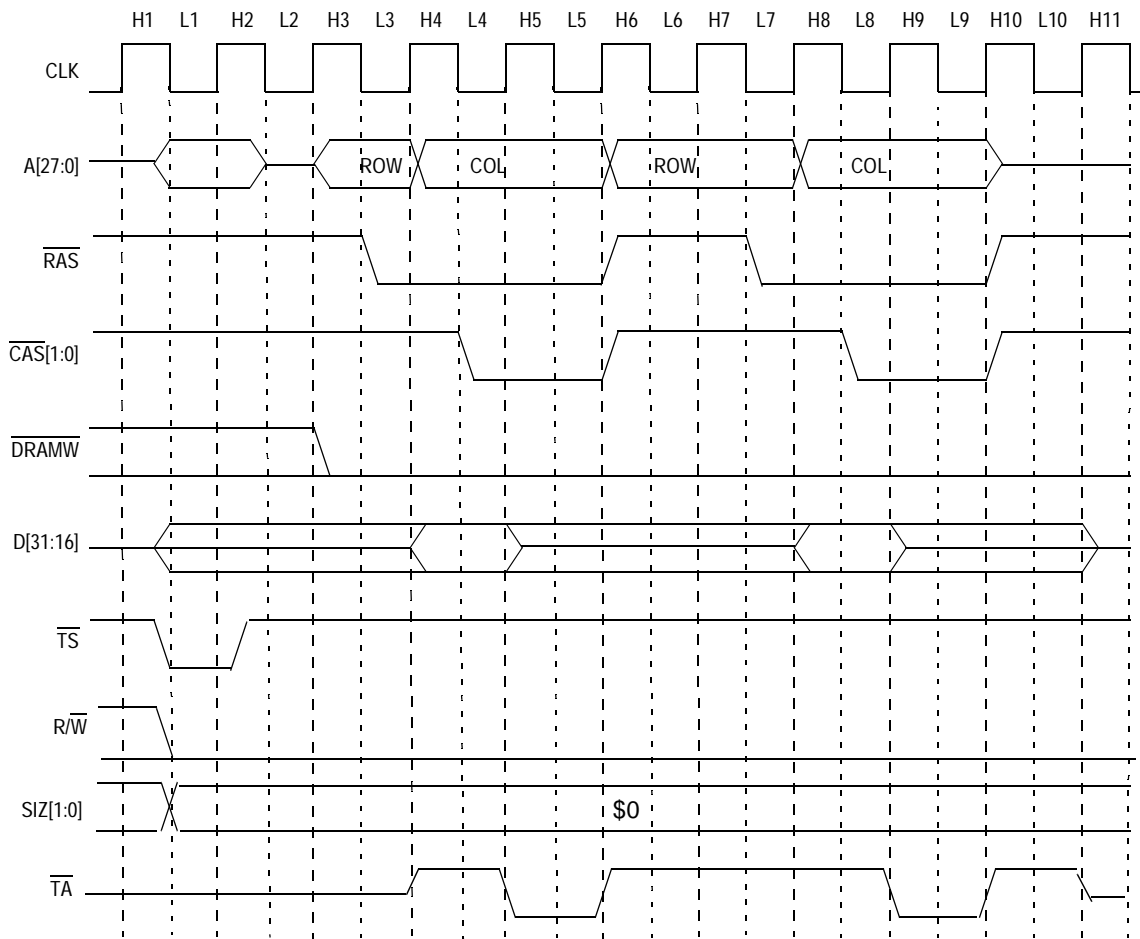

Figure 11-15. External Master Longword Write Transfer in Normal Mode with 16-Bit DRAM

Clock H1/L1

An external master is the current bus master. The external master starts a DRAM transfer by driving A[27:0], driving R/W low indicating a write transfer, driving SIZ[1:0] to \$0 indicating a longword transfer, and asserting TS. These inputs to the MCF5206e must be set up with respect to the rising edge of CLK H2. The external master must drive the data

in the correct byte lanes based on the data size and the port size of the DRAM, and must drive the data to meet the timing specifications of the DRAM. In this case, the external master should drive the write data on D[31:16].

Clock H2

On the rising edge of CLK when \overline{TS} is asserted, the MCF5206e registers the address and attribute signals. It internally decodes these signals and determines if the external master transfer is a DRAM access. The external master negates \overline{TS} and must three-state A[27:0] after the rising edge of CLK H2, if the internal address multiplexing is to be used.

Clock H3

The MCF5206e has determined that the external master transfer is a DRAM access, so the MCF5206e drives A[27:0] with the same value as was registered on the rising edge of H2. A[27:9] contain the DRAM row address. The MCF5206e also drives \overline{DRAMW} low indicating a DRAM write cycle.

Clock L3

The MCF5206e asserts \overline{RAS} to indicate the row address is valid on A[27:9].

Clock H4

The MCF5206e internally multiplexes the address and drives out the column address on A[27:9]. The MCF5206e also actively drives \overline{TA} negated.

Clock L4

The MCF5206e asserts $\overline{CAS}[1:0]$ to indicate the column address is valid on A[27:9]. The external master must set up and hold the first word of data on D[31:16] with respect to the falling edge of $\overline{CAS}[1:0]$ based on the DRAM specifications.

Clock H5

The MCF5206e asserts the \overline{TA} signal to indicate that the first word write transfer of the longword burst will be completed on the next rising edge of CLK.

Clock H6

The MCF5206e negates \overline{RAS} , $\overline{CAS}[1:0]$, and \overline{TA} , ending the first word transfer of the longword burst. The negation of \overline{RAS} starts the \overline{RAS} precharge. The MCF5206e drives the row address again for second word transfer of the longword burst write.

Clock L7

Once the \overline{RAS} precharge time has been met, the MCF5206e asserts \overline{RAS} to indicate the row address is valid on A[27:9].

Clock H8

The MCF5206e internally increments and multiplexes the address and drives out the column address on A[27:9] for the second word transfer of the longword burst write.

Clock L8

Clock L8 is the same as Clock L4. The MCF5206e asserts $\overline{\text{CAS}}[1:0]$ to indicate the column address is valid on A[27:9]. The external master must set up and hold the second word of data on D[31:16] with respect to the falling edge of $\overline{\text{CAS}}[1:0]$ based on the DRAM specifications.

Clock H9

Clock H9 is the same as Clock H5. The MCF5206e asserts the $\overline{\text{TA}}$ signal to indicate that the second word write transfer of the longword burst will be completed on the next rising edge of CLK.

Clock H10

The MCF5206e negates $\overline{\text{RAS}}$, $\overline{\text{CAS}}[1:0]$, and $\overline{\text{TA}}$, and three-states A[27:0], ending the second word transfer of the longword burst. The negation of $\overline{\text{RAS}}$ starts the $\overline{\text{RAS}}$ precharge. Once A[27:0] has three-stated, the external master can start another transfer.

Clock H11

The MCF5206e three-states $\overline{\text{TA}}$.

11.3.8.3 EXTERNAL MASTER BURST TRANSFER IN BURST PAGE MODE. Burst page mode does fast page mode transfers only for burst transfers. A burst transfer to DRAM is generated any time the operand size is larger than the DRAM bank port size (e.g., line transfer to a 32-bit port, longword transfer to an 8-bit port). After completing the burst transfer, the MCF5206e negates $\overline{\text{RAS}}$, closing the page. Because all secondary transfers of a burst are guaranteed to be page hits, a page miss never occurs in burst page mode. Nonburst transfers occur as in normal mode (for nonburst transfers in burst page mode, refer to **Section 11.3.8.1 External Master Non Burst Transfer in Normal Mode**). Therefore, burst page mode always provides the same or better performance than normal mode.

Because the DRAMC does not support fast page mode for external master transfers, a DRAM bank programmed for either burst page mode or fast page mode operates as burst page mode.

The timing of read transfers and write transfers is identical in burst page mode, with the exception of when the DRAM drives data on reads and when the external master drives data on writes.

The fastest possible external master burst transfer in burst page mode requires 5 clocks for the first transfer of the burst and two clocks for the secondary transfers. The fastest

possible nonburst transfer in burst page mode requires 5 clocks. You can program the DCTR to generate slower burst-page-mode transfers.

Figure 11-16 illustrates the timing of a word read transfer to an 8-bit DRAM in burst page mode. In burst page mode after the first byte transfer of the burst is complete, $\overline{\text{RAS}}$ remains asserted while $\overline{\text{CAS}}[0]$ and $\overline{\text{TA}}$ are negated and the column address of the second byte transfer of the burst is driven. After the $\overline{\text{CAS}}$ precharge time is met, $\overline{\text{CAS}}[0]$ asserts for the second byte read transfer. When the second byte read transfer is completed, $\overline{\text{RAS}}$, $\overline{\text{CAS}}[0]$, and $\overline{\text{TA}}$ are negated, ending the burst transfer.

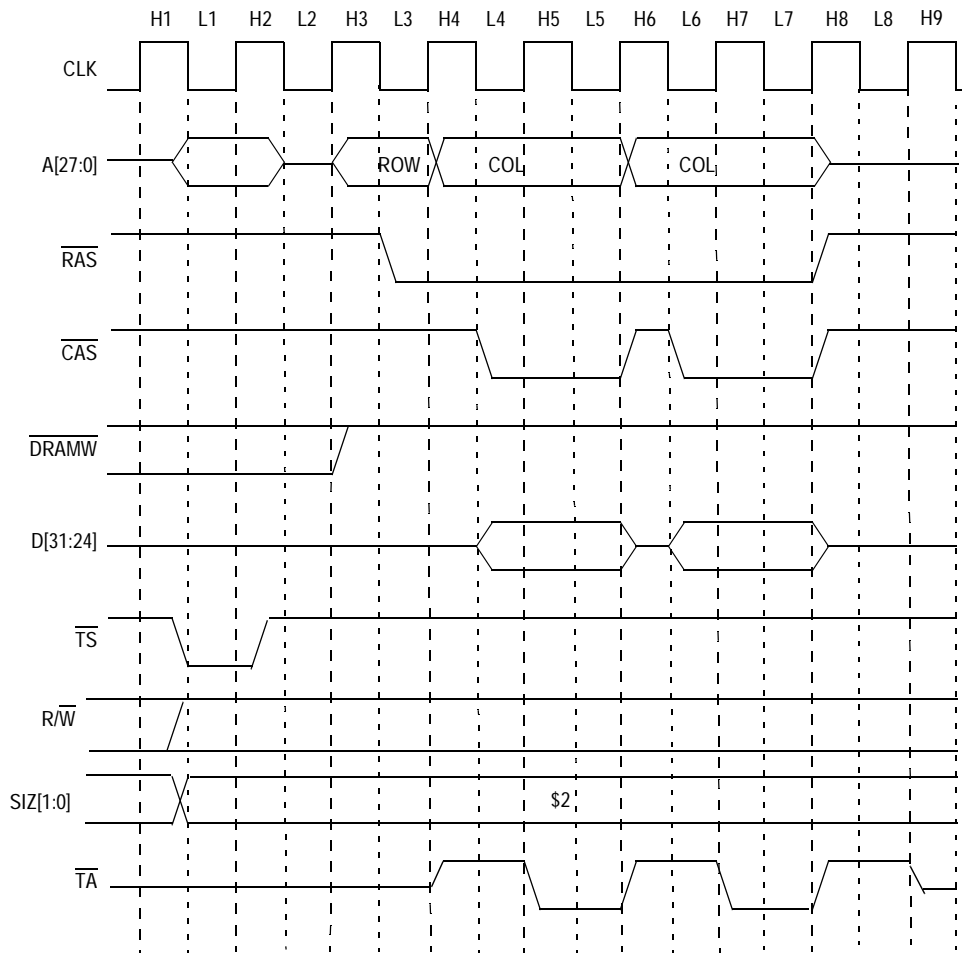

Figure 11-16. External Master Word Read Transfer in Burst Page Mode with 8-Bit DRAM

Clock H1/L1

An external master is the current bus master. The external master starts a DRAM burst word-write transfer by driving $\text{A}[27:0]$, driving $\text{R}/\overline{\text{W}}$ high indicating a read transfer, driving

$\overline{SIZ}[1:0]$ to $\$2$ indicating a word transfer, and asserting \overline{TS} . These inputs to the MCF5206e must be set up with respect to the rising edge of CLK H2.

Clock H2

On the rising edge of CLK when \overline{TS} is asserted, the MCF5206e registers the address and attribute signals. It internally decodes these signals and determines if the external master transfer is a DRAM access. The external master negates \overline{TS} and must three-state A[27:0] after the rising edge of CLK H2, if the internal address multiplexing is to be used.

Clock H3

The MCF5206e has determined that the external master transfer is a DRAM access, so the MCF5206e drives A[27:0] with the same value as was registered on the rising edge of H2. A[27:9] contain the DRAM row address. The MCF5206e also drives \overline{DRAMW} high indicating a DRAM read cycle.

Clock L3

The MCF5206e asserts \overline{RAS} to indicate the row address is valid on A[27:9].

Clock H4

The MCF5206e internally multiplexes the address and drives out the column address on A[27:9]. The MCF5206e also actively drives \overline{TA} negated.

Clock L4

The MCF5206e asserts $\overline{CAS}[0]$ to indicate the column address is valid on A[27:9]. At this point the DRAM drives the data on D[31:24].

Clock H5

The MCF5206e asserts the \overline{TA} signal to indicate that the first byte read transfer of the burst will be completed and the read data will be valid on D[31:24] on the next rising edge of CLK.

Clock H6

The MCF5206e negates $\overline{CAS}[0]$, and \overline{TA} , ending the first byte read transfer of the burst. Because the bank is in burst page mode, the MCF5206e continues to assert \overline{RAS} . The negation of $\overline{CAS}[0]$ starts the CAS precharge. The MCF5206e drives the column address on A[27:9] for second byte read transfer of the burst.

Clock L6

After the \overline{CAS} precharge time is met, the MCF5206e asserts $\overline{CAS}[0]$ to indicate the column address is valid on A[27:9]. At this point the DRAM drives the data bus.

Clock H7

The MCF5206e asserts the \overline{TA} signal to indicate that the first byte read transfer of the burst will be completed and the read data will be valid on D[31:24] on the next rising edge of CLK.

Clock H8

The MCF5206e negates \overline{RAS} , $\overline{CAS}[0]$, and \overline{TA} , and three-states A[27:0], ending the final byte read transfer of the burst. Because the bank is in burst page mode, MCF5206e negates \overline{RAS} when the burst transfer is completed. The negation of \overline{RAS} starts the \overline{RAS} precharge. Once A[27:0] has three-stated, the external master can start another transfer.

Clock H9

The MCF5206e three-states \overline{TA} .

11.3.8.4 LIMITATIONS. Because the external and internal address buses differ in size and address multiplexing occurs for transfers to DRAM, certain limitations exist for external master use of the DRAMC.

- Fast page mode is not available for external master transfers. If a bank has this featured enabled, then burst page mode is used for external master transfers and fast page mode is used for ColdFire core-initiated transfers.
- The UC, UD, SC, and SD mask bits are ignored during external master-initiated transfers. Therefore, if UC, UD, SC, and SD are all masked, that bank is available for external master transfers even though the bank is unavailable for ColdFire core-initiated transfers.
- In determining whether an external master transfer address hits in a DRAM bank, the bits of the internal address bus which are unavailable externally are regarded as \$0. A[31:28] are always be set to \$0 and A[27:24] are conditionally (based on PAR) be set to \$0. In order for a bank to be accessible for external-master transfers, the address bits that are unavailable to the external master must either be set to 0 in the DCAR or be masked in the DCMR.
- DRAM bank size is limited by the availability of A[27:24] as determined by the PAR control register.

11.4 PROGRAMMING MODEL

11.4.1 DRAM Controller Registers Memory Map

Table 11-10 shows the memory map of all the DRAMC registers. The internal registers in the DRAM controller are memory-mapped registers offset from the MBAR address pointer.

The following lists several key notes regarding the programming model table:

- Addresses not assigned to a register and undefined register bits are reserved for future expansion. Write accesses to these reserved address spaces and reserved register bits have no effect; read accesses return zeros.
- The reset value column indicates the register initial value at master reset and normal reset. Certain registers are uninitialized upon reset—they may contain random values after reset.
- The access column indicates if the corresponding register allows both read/write functionality (R/W), read-only functionality (R), or write-only functionality (W). If a read access to a write-only register is attempted, zeros are returned. If a write access to a read-only register is attempted, the access is ignored and no write occurs.

Table 11-10. Memory Map of DRAM Controller Registers

ADDRESS	NAME	WIDTH	DESCRIPTION	RESET VALUE	ACCESS
MBAR + \$46	DCRR	16	DRAM Controller Refresh	Master Reset: \$0000 Normal Reset: uninitialized	R/W
MBAR + \$4A	DCTR	16	DRAM Controller Timing Register	Master Reset: \$0000 Normal Reset: uninitialized	R/W
MBAR + \$4C	DCAR0	16	DRAM Controller Address Register - Bank 0	Master Reset: uninitialized Normal Reset: uninitialized	R/W
MBAR + \$50	DCMR0	32	DRAM Controller Mask Register - Bank 0	Master Reset: uninitialized Normal Reset: uninitialized	R/W
MBAR + \$57	DCCR0	8	DRAM Controller Control Register- Bank 0	Master Reset: \$00 Normal Reset: \$00	R/W
MBAR + \$58	DCAR1	16	DRAM Controller Address Register - Bank 1	Master Reset: uninitialized Normal Reset: uninitialized	R/W
MBAR + \$5C	DCMR1	32	DRAM Controller Mask Register - Bank 1	Master Reset: uninitialized Normal Reset: uninitialized	R/W
MBAR + \$63	DCCR1	8	DRAM Controller Control Register - Bank 1	Master Reset: \$00 Normal Reset: \$00	R/W

11.4.2 DRAM Controller Registers

11.4.2.1 DRAM CONTROLLER REFRESH REGISTER (DCRR). The DRAM Controller Refresh Register (DCRR) controls the number of system clocks between refresh cycles. The DCRR is a 16-bit read/write control register. The DCRR is set to \$0000 by master reset (corresponding to the slowest refresh rate) and is unaffected by normal reset.

DRAM Controller Refresh Counter(DCRR) Address MBAR + \$46

15	14	13	12	11	10	9	8	7	6	5	4	3	2	1	0
-	-	-	-	RC11	RC10	RC9	RC8	RC7	RC6	RC5	RC4	RC3	RC2	RC1	RC0
MASTER RESET:															
0	0	0	0	0	0	0	0	0	0	0	0	0	0	0	0
NORMAL RESET:															
0	0	0	0	-	-	-	-	-	-	-	-	-	-	-	-

RC11 - RC0 - Refresh Count

This field controls the frequency of refresh requests. The value stored in this field is multiplied by 16 system clocks to determine the refresh period. The refresh period can range from 16 system clocks to 65,536 system clocks. An RC field value of all zeros corresponds to 65,536 system clocks. Any write to the DCRR forces a refresh cycle to occur. The refresh period can be calculated using the following equations:

For RC>\$000:

$$\text{Refresh period} = \text{RC} \times 16 \times (1/\text{system clock frequency})$$

For RC=\$000:

$$\text{Refresh period} = 65536 \times (1/\text{system clock frequency})$$

11.4.2.2 DRAM CONTROLLER TIMING REGISTER (DCTR). The DCTR controls the waveform timing for all DRAM transfers. The fields in this register control the RAS and CAS waveform timing for all types of DRAM transfers provided by the DRAMC. The DCTR is a 16-bit read/write control register. The DCTR is set to \$0000 by master reset and is unaffected by normal reset.

DRAM Controller Timing Register(DCTR)														Address MBAR + \$4A	
15	14	13	12	11	10	9	8	7	6	5	4	3	2	1	0
DAEM	EDO	-	RCD	-	RSH1	RSH0	-	-	RP1	RP0	-	CAS	-	CP	CSR
MASTER RESET:															
0	0	0	0	0	0	0	0	0	0	0	0	0	0	0	0
NORMAL RESET:															
-	-	0	-	0	-	-	0	0	-	-	0	-	0	-	-

DAEM - Drive Multiplexed Address During External Master DRAM transfers

This field controls the MCF5206e output driver enables for the external address bus during external master transfers that hit in DRAM address space. If DAEM is set to 1, the portion of A[27]/CS[7]/WE[0], A[26]/CS[6]/WE[1], A[25]/CS[5]/WE[2], A[24]/CS[4]/WE[3] that are configured as address signals are driven along with A[23:0] to provide row and column address multiplexing for external masters. This field does not affect the address multiplexing for DRAM transfers initiated by the ColdFire core.

0 = Do not drive the external address signals as outputs during external master DRAM transfers

1 = Drive the external address signals as outputs to provide row and column address multiplexing during external master DRAM transfers

EDO - Extended Data-Out Enable

This field controls page mode CAS timing. If the DRAM banks are populated with extended data-out DRAM, the EDO Enable bit can be set to take advantage of the CAS timing allowed by EDO DRAMs. The EDO Enable bit, along with the CAS and CP bits,

control the $\overline{\text{CAS}}$ assertion and negation time during fast page mode and burst page mode transfers. Refer to Figure 11-21 for a timing diagram of EDO DRAM page mode transfers.

- 0 = DRAM banks are populated with standard DRAM, do not use EDO $\overline{\text{CAS}}$ timing
- 1 = DRAM banks are populated with EDO DRAM, use EDO $\overline{\text{CAS}}$ timing

NOTE

If neither fast page mode or burst page mode are enabled in the DRAM Control Register (DCCR), the EDO Enable bit has no effect on the DRAM waveform timing.

RCD - $\overline{\text{RAS}}$ -to- $\overline{\text{CAS}}$ Delay Time

This field controls the number of system clocks between the assertion of $\overline{\text{RAS}}$ and the assertion of $\overline{\text{CAS}}$ for transfers in normal mode and for the initial transfer to a page in fast page mode and burst page mode. Because the column address is always driven 0.5 system clocks prior to the assertion of $\overline{\text{CAS}}$, RCD affects the driving of the column address. RCD does not affect refresh cycles. Refer to Figure 11-17 for normal mode timing. Refer to Figures 11-18 and 11-19 for fast page mode and burst page mode timing.

- 0 = $\overline{\text{RAS}}$ asserts 1.0 system clock before the assertion of $\overline{\text{CAS}}$
- 1 = $\overline{\text{RAS}}$ asserts 2.0 system clocks before the assertion of $\overline{\text{CAS}}$

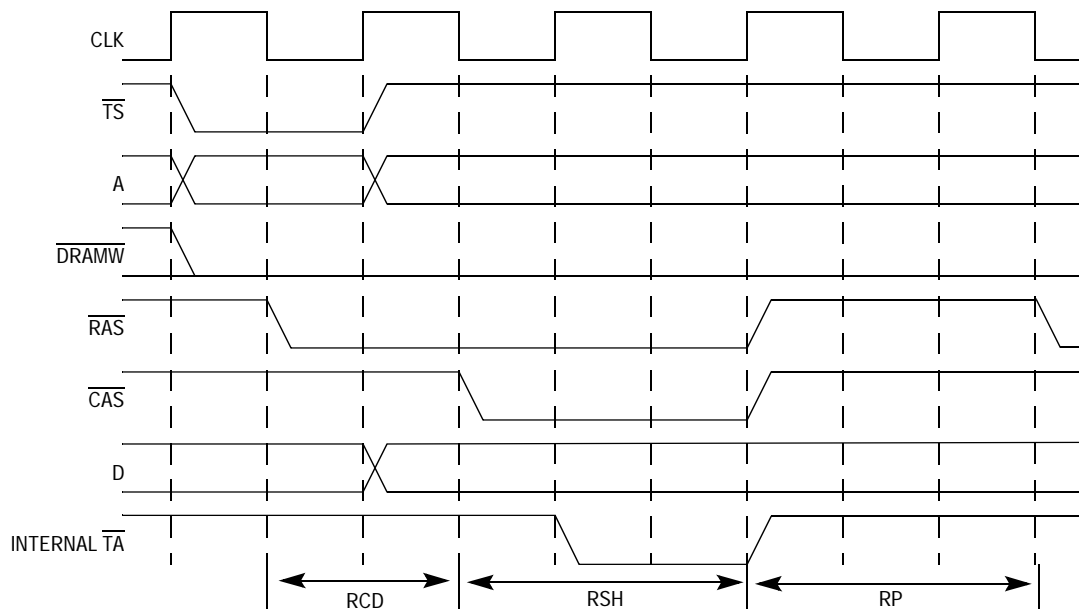

Figure 11-17. Normal Mode DRAM Transfer Timing

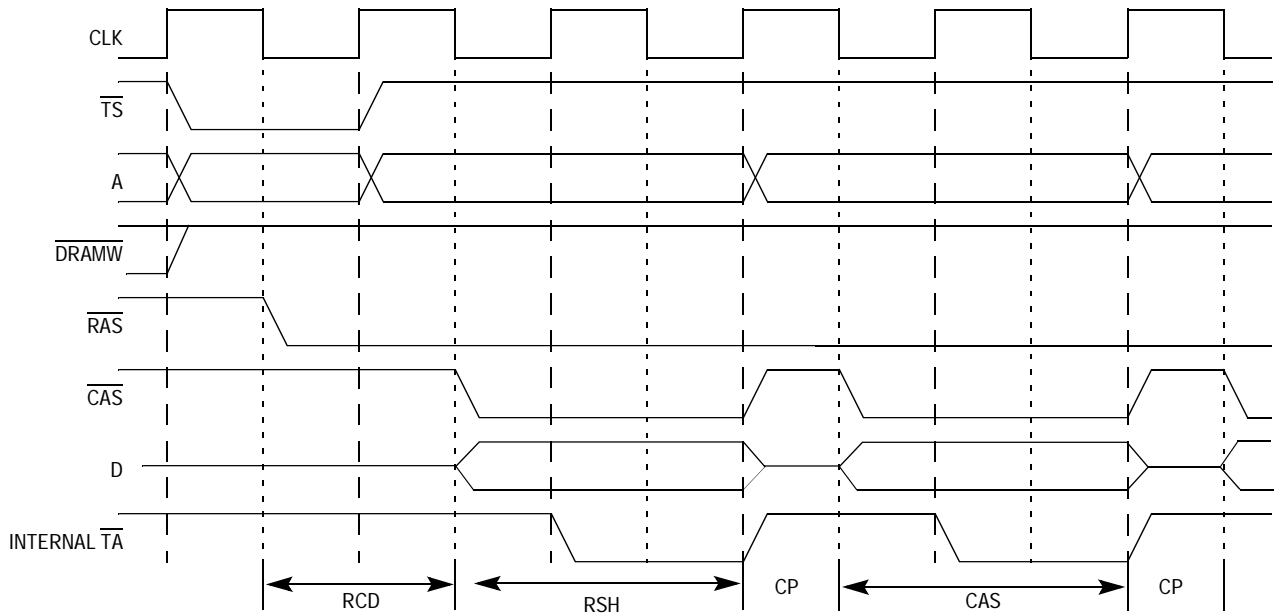

Figure 11-18. Fast Page Mode or Burst Page Mode DRAM Transfer Timing

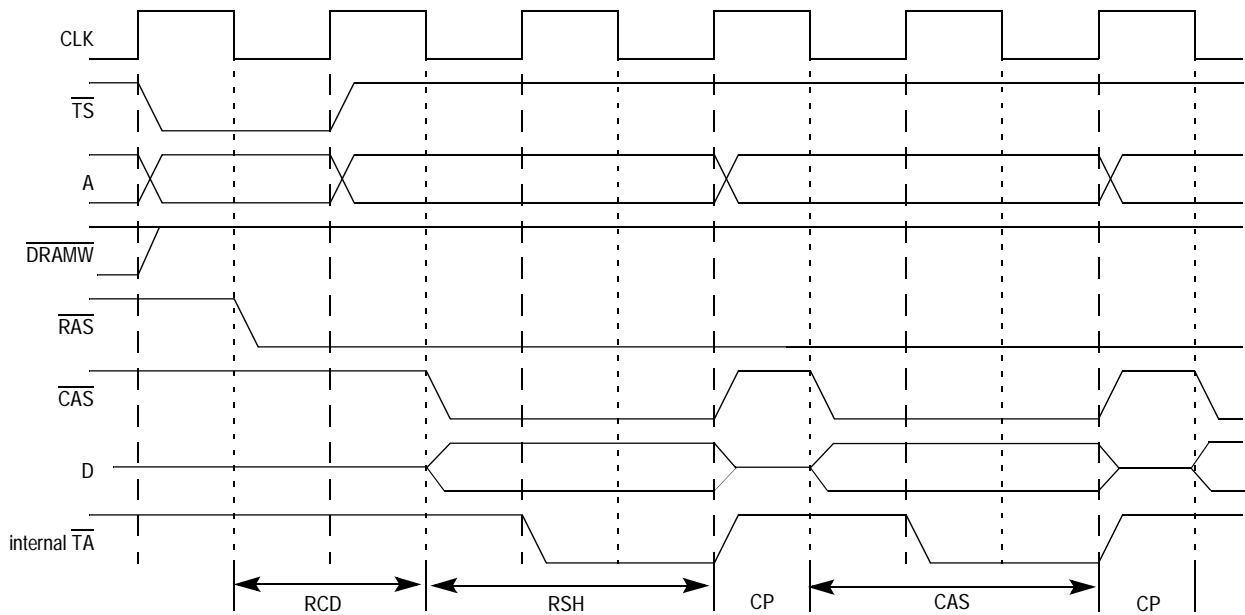

Figure 11-19. Fast Page Mode or Burst Page Mode DRAM Transfer Timing

RSH1 - RSH0 - $\overline{\text{RAS}}$ Hold Time

This field controls the number of system clocks that $\overline{\text{RAS}}$ remains asserted after the assertion of $\overline{\text{CAS}}$. This field controls $\overline{\text{RAS}}$ active timing for transfers in normal mode and for the initial transfer in fast page mode and burst page mode. Refer to Figure 11-17 for

normal mode timing. Refer to Figures 11-19 and 11-21 for fast-page-mode and burst-page-mode timing.

For transfers in normal mode:

- 00 = $\overline{\text{RAS}}$ negates 1.5 system clocks after the assertion of $\overline{\text{CAS}}$
- 01 = $\overline{\text{RAS}}$ negates 2.5 system clocks after the assertion of $\overline{\text{CAS}}$
- 10 = $\overline{\text{RAS}}$ negates 3.5 system clocks after the assertion of $\overline{\text{CAS}}$
- 11 = Reserved

For the initial transfer in fast page mode and burst page mode with EDO Enable = 0:

- 00 = $\overline{\text{RAS}}$ negates 1.5 system clocks after the assertion of $\overline{\text{CAS}}$
- 01 = $\overline{\text{RAS}}$ negates 2.5 system clocks after the assertion of $\overline{\text{CAS}}$
- 10 = $\overline{\text{RAS}}$ negates 3.5 system clocks after the assertion of $\overline{\text{CAS}}$
- 11 = Reserved

For initial transfer in fast page mode and burst page mode with EDO Enable = 1:

- 00 = $\overline{\text{RAS}}$ negates 1.0 system clock after the assertion of $\overline{\text{CAS}}$
- 01 = $\overline{\text{RAS}}$ negates 2.0 system clocks after the assertion of $\overline{\text{CAS}}$
- 10 = $\overline{\text{RAS}}$ negates 3.0 system clocks after the assertion of $\overline{\text{CAS}}$
- 11 = Reserved

RP1 - RP0 - $\overline{\text{RAS}}$ Precharge Time

This field controls the number of system clocks $\overline{\text{RAS}}$ precharges when the bus master requires back-to-back DRAM transfers in normal mode. RP also controls the number system clocks $\overline{\text{RAS}}$ precharges after a refresh cycle or when a page is closed in fast page mode or burst page mode. Refer to Figure 11-22 for refresh cycle timing. Refer to Figure 11-17 for normal mode timing. Refer to Figure 11-20 for fast page-mode timing.

- 00 = $\overline{\text{RAS}}$ precharges for 1.5 system clocks
- 01 = $\overline{\text{RAS}}$ precharges for 2.5 system clocks
- 10 = $\overline{\text{RAS}}$ precharges for 3.5 system clocks
- 11 = Reserved

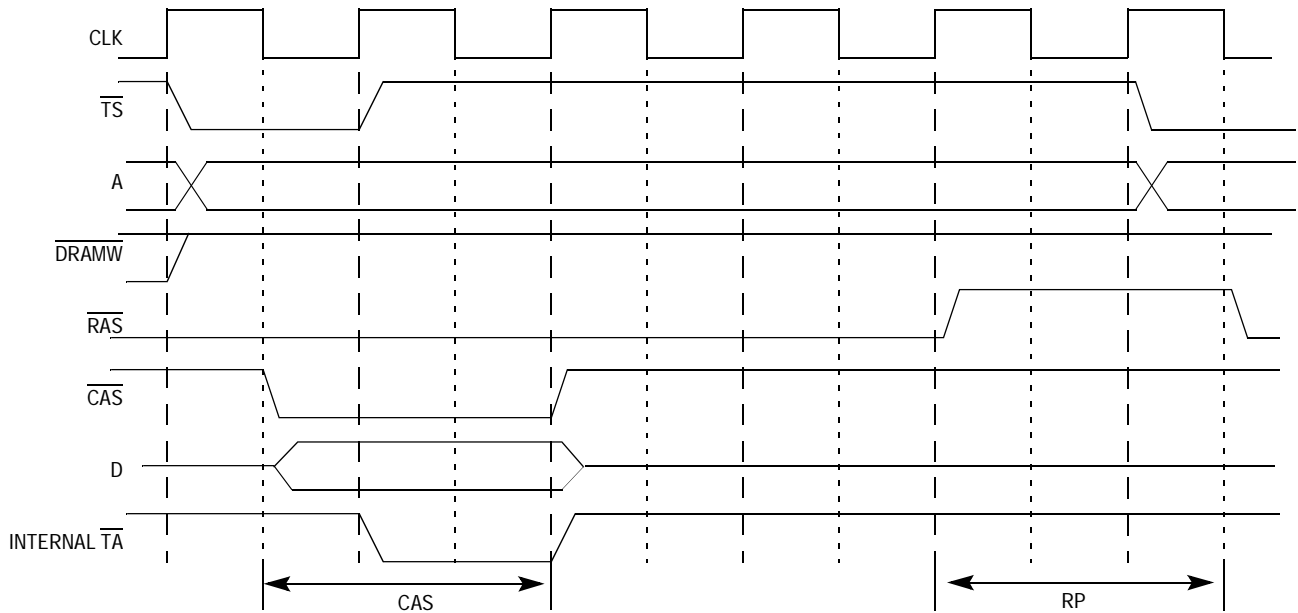

Figure 11-20. Fast Page Mode Page Hit and Page Miss DRAM Transfer Timing

CAS - Column Address Strobe Time

This field, together with the EDO field, controls the number of system clocks that \overline{CAS} asserts on transfers once a page is open in fast page mode and burst page mode. Refer to Figure 11-18 for timing diagrams of fast-page-mode or burst-page-mode transfers to standard DRAMs and Figure 11-21 for fast-page-mode or burst-page-mode transfers to EDO DRAMs.

For EDO = 0:

- 0 = \overline{CAS} is asserted for 1.5 system clocks
- 1 = \overline{CAS} is asserted for 2.5 system clocks

For EDO = 1:

- 0 = \overline{CAS} is asserted for 1.0 system clock
- 1 = \overline{CAS} is asserted for 2.0 system clocks

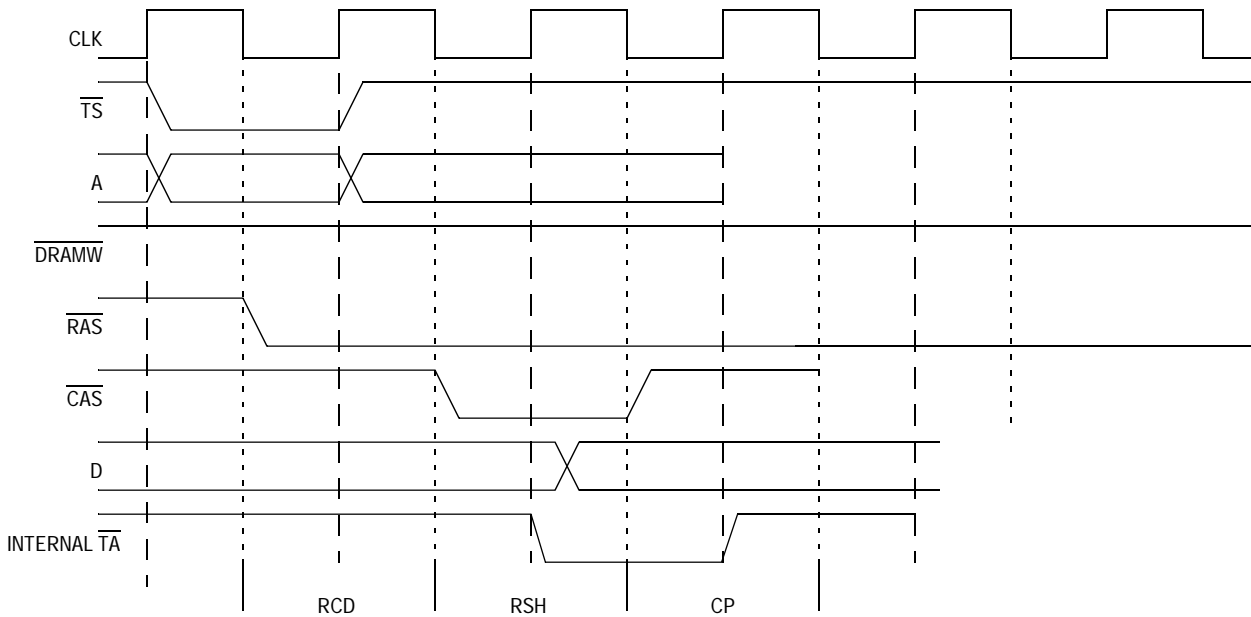

Figure 11-21. Fast Page Mode or Burst Page Mode EDO DRAM Transfer Timing

CP - \overline{CAS} Precharge Time

This field, together with the EDO field, controls the number of system clocks that \overline{CAS} is negated after a page mode transfer. This field controls \overline{CAS} timing for fast page mode and burst page mode. Refer to Figures 11-6 and 11-7 for timing diagrams illustrating \overline{CAS} precharge timing in fast page mode and burst page mode using standard and EDO DRAMs.

For EDO Enable = 0:

- 0 = \overline{CAS} is negated for 0.5 system clocks
- 1 = \overline{CAS} is negated for 1.5 system clocks

For EDO Enable = 1:

- 0 = \overline{CAS} is negated for 1.0 system clock
- 1 = \overline{CAS} is negated for 2.0 system clocks

CSR - \overline{CAS} Setup Time for \overline{CAS} Before \overline{RAS} Refresh

This field controls the number of system clocks between the assertion of \overline{CAS} and the assertion of \overline{RAS} during refresh cycles. This field does not affect normal mode, fast page mode, or burst-page-mode transfer timing. Refer to Figure 11-22 for refresh cycle timing.

- 0 = \overline{CAS} asserts 1.0 system clock before the assertion of \overline{RAS}
- 1 = \overline{CAS} asserts 2.0 system clocks before the assertion of \overline{RAS}

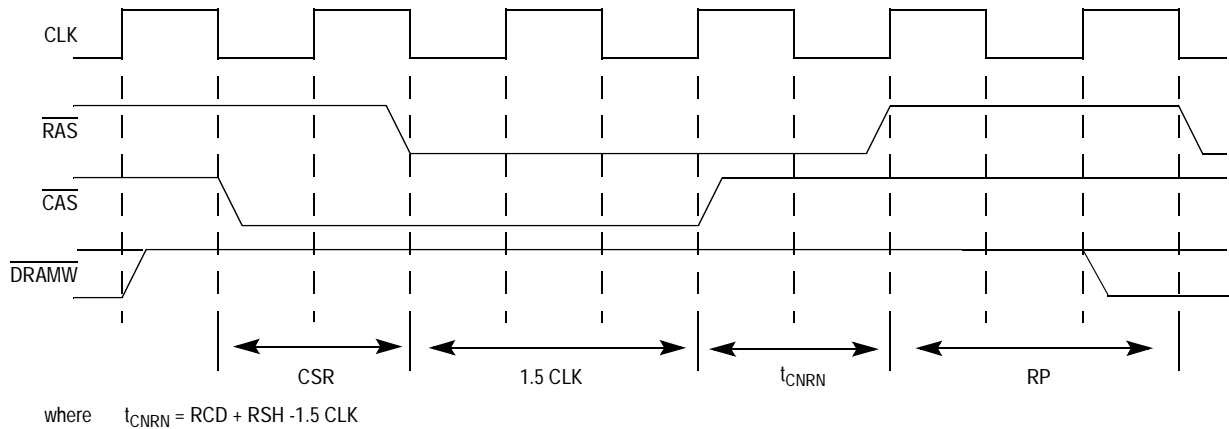

Figure 11-22. $\overline{\text{CAS}}$ Before $\overline{\text{RAS}}$ Refresh Cycle Timing

NOTE

The DCTR should not be written while an external master transfer is in progress. The DCTR should be programmed as part of the initialization sequence and external master DRAM transfers should not be attempted until it has been written. Failure to do so results in unpredictable operation.

11.4.2.3 DRAM CONTROLLER ADDRESS REGISTERS (DCAR0 - DCAR1). Each DCAR holds the base address of the corresponding DRAM bank. Each DCAR is a 16-bit read/write control register. All bits in DCAR0 - DCAR1 are unaffected by either master reset or normal reset.

DRAM Controller Address Register(DCAR)														Address MBAR + \$4C (Bank0)		Address MBAR + \$58 (Bank1)	
31	30	29	28	27	26	25	24	23	22	21	20	19	18	17	16		
BA31	BA30	BA29	BA28	BA27	BA26	BA25	BA24	BA23	BA22	BA21	BA20	BA19	BA18	BA17	-		
NORMAL OR MASTER RESET:																	0

BA31-BA17 - Base Address

This field defines the base address location of each DRAM bank. These bits are compared to bits 31-17 of the transfer address to determine if the DRAM bank is being accessed.

NOTE

In determining whether an external master transfer address hits in a DRAM bank, the portion of the address bus that is unavailable externally is regarded as \$0. That is, the external master transfer address always has A[31:28] as \$0 and those bits of A[27:24] that are not programmed to be external

address bits as \$0. In order for a bank to be accessible to an external master, the address bits that are unavailable to the external master must either be set to 0 in the DCAR or be masked in the DCMR.

11.4.2.4 DRAM CONTROLLER MASK REGISTER (DCMR0 - DCMR1). Each DCMR holds the address mask for each of the DRAM banks as well the definition of which types of transfers are allowed for the DRAM banks. Each DCMR is a 32-bit read/write control register. All bits in DCMR0 - DCMR1 are unaffected by either Master Reset or normal reset.

DRAM Controller Mask Register(DCMR)

															Address MBAR + \$50 (Bank 0)		Address MBAR + \$5C (Bank 1)															
31	30	29	28	27	26	25	24	23	22	21	20	19	18	17	16																	
BAM31	BAM30	BAM29	BAM28	BAM27	BAM26	BAM25	BAM24	BAM23	BAM22	BAM21	BAM20	BAM19	BAM18	BAM17	-																	
NORMAL OR MASTER RESET:															-	-	-	-	-	-	-	-	-	-	-	-	-	-	-	-	-	0
15	14	13	12	11	10	9	8	7	6	5	4	3	2	1	0																	
-	-	-	-	-	-	-	-	-	-	-	SC	SD	UC	UD	-																	
NORMAL OR MASTER RESET:															0	0	0	0	0	0	0	0	0	0	-	-	-	-	-	-	-	0

BAM [31:17] - Base Address Mask

This field defines the DRAM address space through the use of address mask bits. Any bit set to 1 masks the corresponding base address register (DCAR) bit (the base address bit becomes a “don’t care” in the address comparison). Unmasked base address bits are compared to the ColdFire core or external master transfer address to determine if the transfer is accessing a DRAM address space.

- 0 = Corresponding address bit is used in DRAM bank decode
- 1 = Corresponding address bit is a “don’t care” in DRAM bank decode

SC, SD, UC, UD - Supervisor Code, Supervisor Data, User Code, User Data Transfer Mask

This field masks allows specific types of transfers to be inhibited from accessing the DRAM bank. If a transfer mask bit is cleared, a transfer of that type can access the corresponding DRAM bank. If a transfer mask bit is set to 1, an transfer of that type can not access the corresponding DRAM bank. The transfer mask bits are:

- SC = Supervisor Code mask
- SD = Supervisor Data mask
- UC = User Code mask
- UD = User Data mask

For each transfer mask bit:

- 0 = Do not mask this type of transfer for the DRAM bank. A transfer of this type can access the DRAM bank.
- 1 = Mask this type of transfer for the DRAM bank. A transfer of this type cannot access the DRAM bank.

NOTE

The SC, SD, UC, and UD bits are ignored during external master transfers. Therefore, an external master transfer can access the DRAM banks regardless of the transfer masks.

NOTE

In determining whether an external master transfer address hits in a DRAM bank, the portion of the address bus that is unavailable externally is regarded as \$0. That is, the external master transfer address always has A[31:28] as \$0 and those bits of A[27:24] that are not programmed to be external address bits as \$0. In order for a bank to be accessible to an external master, the address bits that are unavailable to the external master must either be set to 0 in the DCAR or be masked in the DCMR.

11.4.2.5 DRAM CONTROLLER CONTROL REGISTER (DCCR0 - DCCR1). Each DCCR specifies the port size, page size, page mode, and activation of each of the DRAM banks. Each DCCR is an 8-bit read/write control register. Master reset and normal reset set all bits to zero.

DRAM Controller Control Register(DCCR)					Address MBAR + \$57 (Bank0) Address MBAR + \$63 (Bank1)		
7	6	5	4	3	2	1	0
PS1	PS0	BPS1	BPS0	PM1	PM0	WR	RD
NORMAL OR MASTER RESET:							
0	0	0	0	0	0	0	0

PS - Port Size

This field specifies the data width of the DRAM bank. PS determines the byte lanes that data will be driven on during write cycles and the byte lanes that data is sampled from during read cycles.

- 00 = 32-bit port size - Data sampled and driven on D[31:0]
- 01 = 8-bit port size - Data sampled and driven on D[31:24] only
- 10 = 16-bit port size - Data sampled and driven on D[31:16] only
- 11 = 16-bit port size - Data sampled and driven on D[31:16] only

BPS - Bank Page Size

This field defines the bank page size for each DRAM bank for fast page mode and burst page mode.

- 00 = 512 Byte page size
- 01 = 1 KByte page size
- 10 = 2 KByte page size
- 11 = Reserved

PM - Page Mode Select

This field selects the type of DRAM transfers generated for each DRAM bank: normal mode, fast page mode, or burst-page-mode transfers.

- 00 = Normal Mode
- 01 = Burst Page Mode
- 10 = Reserved
- 11 = Fast Page Mode

WR - Write Enable

This field controls whether the DRAM bank can be accessed during write transfers.

- 0 = Do not activate DRAM control signals on write transfers
- 1 = Activate DRAM control signals on write transfers

RD - Read Enable

This field controls whether the DRAM bank can be accessed during read transfers.

- 0 = Do not activate DRAM control signals on read transfers
- 1 = Activate DRAM control signals on read transfers

11.5 DRAM INITIALIZATION EXAMPLE

The following sample assembly program illustrates a DRAM initialization procedure. DRAM bank 0 is configured for a 4 MByte DRAM starting at address \$00100000. The DRAM port size is programmed to 32-bits (1 MByte x 32), the page size to 512 Bytes, and fast page mode is enabled.

The Module Base Address Register (MBAR) is first written with the MODULE_BASE value. This locates all the MCF5206e internal modules at address \$00004000. Then the DRAM Controller Timing Register (DCTR) is initialized to give the fastest possible DRAM transfer waveform timing. The DRAM Controller Refresh Register (DCRR) is then written causing DRAM refresh cycles to be generated once every 512 clocks (12.8 μ sec for a 40 MHz system clock/9.5 μ sec for a 54 MHz system clock). Once the DCRR is written, a refresh cycle is immediately generated and refresh cycles are generated at the newly programmed rate. Next, DRAM Controller Address Register 0 (DCAR0) is written, making the starting address of DRAM bank 0 \$00100000. DRAM Controller Mask Register 0 (DCMR0) is then written such that transfer address bits 18 - 16 are masked, making the DRAM bank 0 address space 1 MByte. Therefore, DRAM bank 0 address space ranges

from \$00100000 - \$001EFFFF. DRAM Controller Control Register 0 (DCCR0) is then written making DRAM bank 0 have a 32-bit port size, a 512 Byte bank page size, generate fast-page-mode transfers, and be enabled for both read transfers and write transfers. At this point, DRAM bank 0 is initialized; however, DRAM read and write transfers will not be generated until the global chip select is disabled by writing CSMR0.

```
#
# set up variables
#
MODULE_BASE equ 0x00004001# base address of internal module registers
DRAM0_BASE equ 0x0010# base address for Bank 0 DRAM
DCRRequ 0x46# DRAMC Refresh Register
DCTRequ 0x4a# DRAMC Timing Register
DCAR0equ 0x4c# DRAMC Address Register 0
DCMR0equ 0x50# DRAMC Mask Register 0
DCCR0equ 0x57# DRAMC Control Register 0
CSMR0equ 0x68# chip select Mask Register 0
#
# DRAMC initialization
#
move.l #MODULE_BASE, d0 # initialize MBAR
movec d0, mbar
move.l #MODULE_BASE, a0 # a0 points to the module base address

move.w #0x00, d0 # initialize for fastest DRAM cycle timing
move.w d0, (DCTR, a0) # (RCD=RSH1=RSH0=RP1=RP0=CAS=CP=CSR=0)

move.w #0x20, d0 # refresh every 512 clocks (15.4 uS @ 33 Mhz)
move.w d0, (DCRR, a0)

move.w #DRAM0_BASE, d0 # set DRAM0 start address at 0x00100000
move.w d0, (DCAR0, a0)

move.l #0x000e0000, d0 # mask low order bits for 1Mbyte address space
move.l d0, (DCMR0, a0) # DRAM0 address space is 0x0010-0x001e0000

move.b #0x0f, d0 # 32-bit port, 512-byte page, fast page mode,
move.b d0, (DCCR0, a0) # readable/writable

# The global chip select activates for ALL external transfers after reset until
# it is disabled. Therefore, before a DRAM transfer can be done, the global chip
# select must be disabled by writing CSMR0.
```

SECTION 12

UART MODULES

The MCF5206e contains two universal asynchronous/synchronous receiver/transmitters (UARTs) that act independently. Each UART is clocked by the system clock, which eliminates the need for an external crystal. This section applies to both UARTs, which are identical. Refer to Section 12.4 for addressing differences.

Each UART module, shown in Figure 12-1, consists of the following major functional areas:

- Serial Communication Channel
- 16-Bit Baud-Rate Timer
- Internal Channel Control Logic
- Interrupt Control Logic

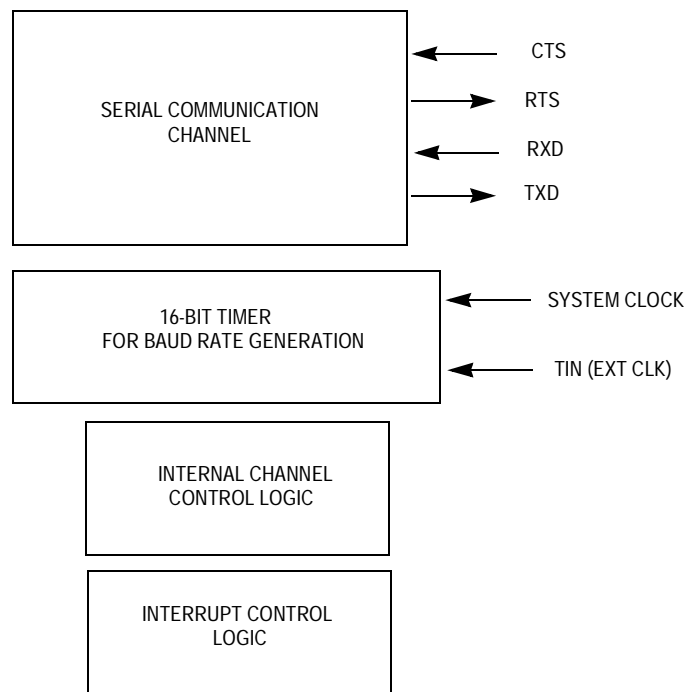

Figure 12-1. UART Block Diagram

12.1 MODULE OVERVIEW

The MCF5206e contains two independent UART modules. Features of each UART module include the following:

- UART clocked by the system clock or external clock (TIN)
- Full duplex asynchronous/synchronous receiver/transmitter channel
- Quadruple-buffered receiver
- Double-buffered transmitter
- Independently programmable baud rate for receiver and transmitter selectable from:
 - timer-generated baud rate or external clock
- Programmable data format:
 - Five to eight data bits plus parity
 - Odd, even, no parity, or force parity
 - .563 to 2 stop bits in x16 mode (asynchronous)/1 or 2 stop bits in synchronous mode
- Programmable channel modes:
 - Normal (full duplex)
 - Automatic echo
 - Local loopback
 - Remote loopback
- Automatic wakeup mode for multidrop applications
- Four maskable interrupt conditions
- Parity, framing, break, and overrun error detection
- False start bit detection
- Line-break detection and generation
- Detection of breaks originating in the middle of a character
- Start/end break interrupt/status

12.1.1 Serial Communication Channel

The communication channel provides a full duplex asynchronous/synchronous receiver and transmitter using an operating frequency derived from the system clock or from an external clock tied to the TIN pin.

The transmitter accepts parallel data from the CPU; converts it to a serial bit stream; inserts the appropriate start, stop, and optional parity bits; then outputs a composite serial data stream on the channel transmitter serial data output (TxD). Refer to **Section 12.3.2.1 Transmitter** for additional information.

The receiver accepts serial data on the channel receiver serial data input (RxD); converts it to parallel format; checks for a start bit, stop bit, parity (if any), or any error condition; and transfers the assembled character onto the bus during read operations. The receiver can be polled or interrupt driven. Refer to **Section 12.3.2.2 Receiver** for additional information.

12.1.2 Baud-Rate Generator/Timer

The 16-bit timer, clocked by the system clock, can function as an asynchronous x16 clock. In addition, you can tie an external clock to one of the TIN pins of a MCF5206e timer for use as a synchronous or asynchronous clocking source for the UART. The baud-rate timer is part of each UART and not related to the ColdFire timer modules.

12.1.3 Interrupt Control Logic

An internal interrupt request signal ($\overline{\text{IRQ}}$) notifies the MCF5206e interrupt controller of an interrupt condition. The output is the logical NOR of all (as many as four) unmasked interrupt status bits in the UART Interrupt Status Register (UISR). You program the UART Interrupt Mask Register (UIMR) to determine which interrupts will be valid in the UISR.

You program the UART module interrupt level in the MCF5206e interrupt controller external to the UART module. You can configure the UART to supply the vector from the UART Interrupt Vector Register (UIVR) or program the SIM to provide an autovector when a UART interrupt is acknowledged.

You can also program the interrupt level, priority within the level, and autovectored capability in the SIM register ICR_U1.

12.2 UART MODULE SIGNAL DEFINITIONS

The following paragraphs contain a brief description of the UART module signals. Figure 12-2 shows both the external and internal signal groups.

NOTE

The terms *assertion* and *negation* are used throughout this section to avoid confusion when dealing with a mixture of active-low and active-high signals. The term *assert* or *assertion* indicates that a signal is active or true, independent of the level represented by a high or low voltage. The term *negate* or *negation* indicates that a signal is inactive or false.

12.2.1 Transmitter Serial Data Output (TxD)

This signal is the transmitter serial data output. The output is held high ("mark" condition) when the transmitter is disabled, idle, or operating in the local loopback mode. Data is shifted out on this signal on the falling edge of the clock source, with the least significant bit transmitted first. All UART pins are muxed with the parallel port. On UART 2, RTS is

muxed with $\overline{\text{RSTO}}$ at the pin. Their functionality is determined by programming the Pin Assignment Register (PAR) in the SIM.

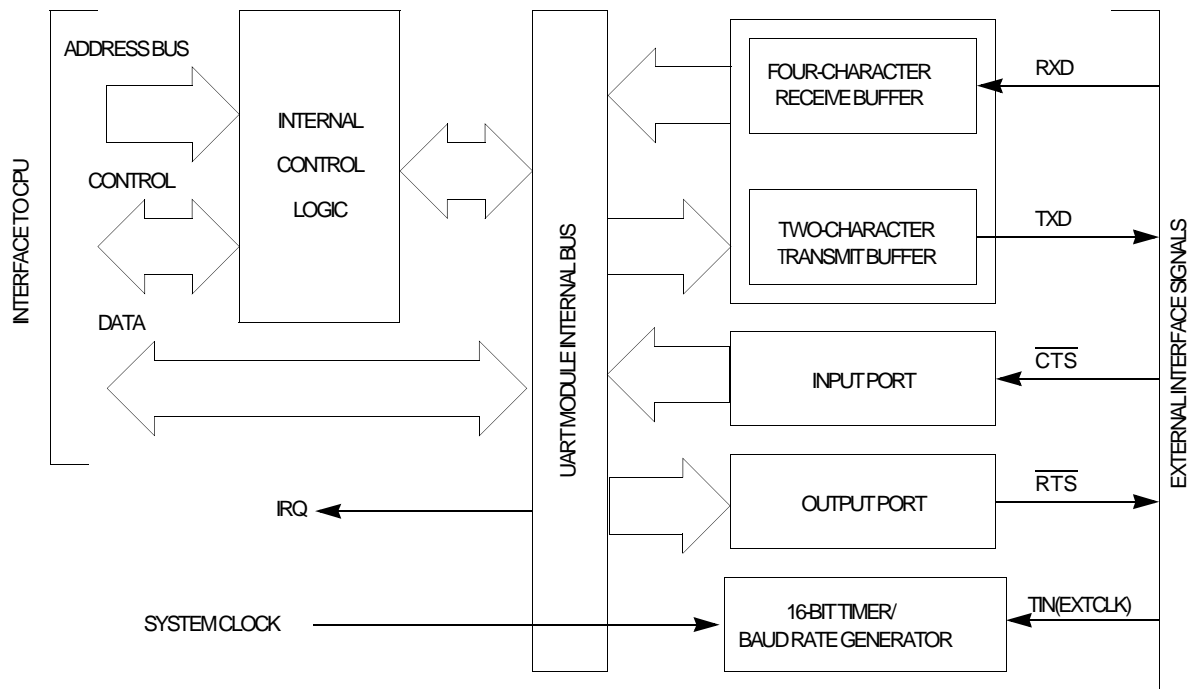

Figure 12-2. External and Internal Interface Signals

12.2.2 Receiver Serial Data Input (RxD)

This signal is the receiver serial data input. Data received on this signal is sampled on the rising edge of the clock source, with the least significant bit received first.

12.2.3 Request-To-Send ($\overline{\text{RTS}}$)

You can program this active-low output signal to be automatically negated and asserted by either the receiver or transmitter. When connected to the clear-to-send (CTS) input of a transmitter, this signal controls serial data flow.

12.2.4 Clear-To-Send ($\overline{\text{CTS}}$)

This active-low input is the clear-to-send input and can generate an interrupt on change-of-state.

12.3 OPERATION

The following paragraphs describe the operation of the baud-rate generator, transmitter and receiver, and other operating modes of the UART module.

12.3.1 Baud-Rate Generator/Timer

The timer references made here relative to clocking the UART are different than the MCF5206e timer module that is integrated on the bus of the ColdFire core. The UART has a baud generator based on an internal baud-rate timer that is dedicated to the UART. You can program the Clock Select Register (USCR) to enable the baud-rate timer or an external clock source from TIN to generate baud rates. When the baud-rate timer is used, a prescaler supplies an asynchronous 32x clock source to the baud-rate timer. The baud-rate timer register value is programmed with the UBG1 and UBG2 registers. See **Section 12.4.1.12 Timer Upper Preload Register 1 (UBG1)** and **Section 12.4.1.13 Timer Upper Preload Register 2 (UBG2)** for more information.

An external TIN clock source, when enabled in the USCR, can generate an x1 or x16 asynchronous or synchronous clock to the UART receiver and transmitter. Figure 12-3 shows the relationship of clocking sources.

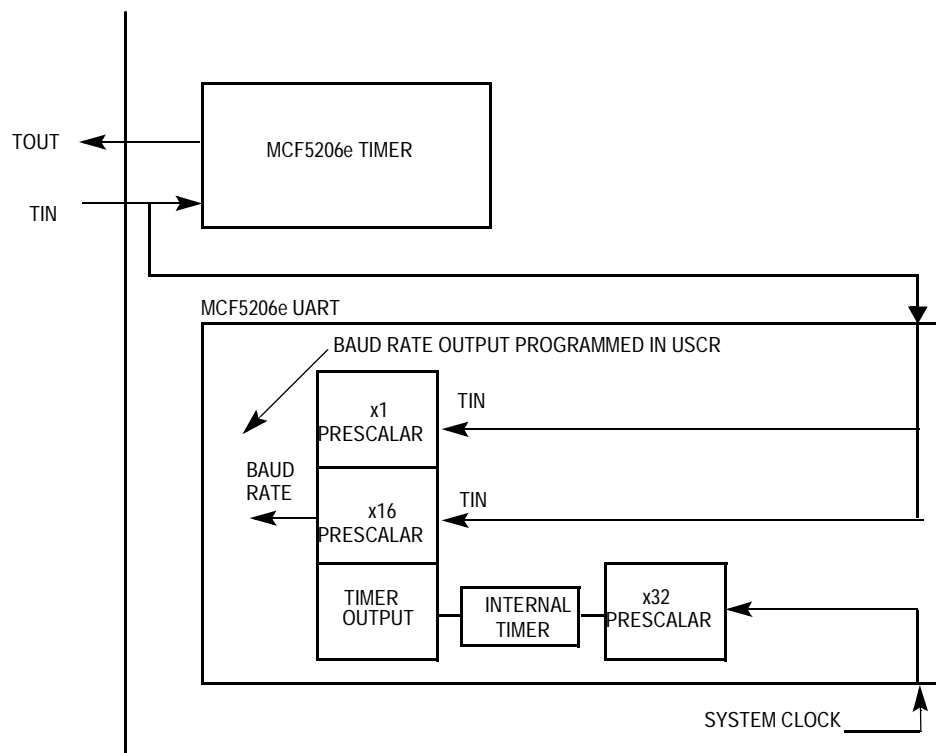

Figure 12-3. Baud-Rate Timer Generator Diagram

12.3.2 Transmitter and Receiver Operating Modes

The functional block diagram of the transmitter and receiver, including command and operating registers, is shown in Figure 12-4. The following paragraphs describe these functions in reference to this diagram. For detailed register information, refer to subsection **12.4 Register Description and Programming**.

12.3.2.1 TRANSMITTER. The transmitter is enabled through the UART command register (UCR) located within the UART module. The UART module signals the CPU when it is ready to accept a character by setting the transmitter-ready bit (TxRDY) in the UART status register (USR). Functional timing information for the transmitter is shown in Figure 12-5.

The transmitter converts parallel data from the CPU to a serial bit stream on TxD. It automatically sends a start bit followed by

- The programmed number of data bits
- An optional parity bit
- The programmed number of stop bits

The least significant bit is sent first. Data is shifted from the transmitter output on the falling edge of the clock source.

After the transmission of the stop bits, if a new character is not available in the transmitter holding register, the TxD output remains in the high (mark condition) state, and the transmitter-empty bit (TxEMP) in the USR is set. Transmission resumes and the TxEMP bit is cleared when the CPU loads a new character into the UART transmitter buffer (UTB). If the transmitter receives a Disable command, it continues operating until the character (if one is present) in the transmit-shift register is completely shifted out of transmitter TxD. If the transmitter is reset through a software command, operation ceases immediately (refer to subsection **Section 12.4.1.5 Command Register (UCR)**). The transmitter is re-enabled through the UCR to resume operation after a disable or software reset.

If clear-to-send operation is enabled, $\overline{\text{CTS}}$ must be asserted for the character to be transmitted. If $\overline{\text{CTS}}$ is negated in the middle of a transmission, the character in the shift register is transmitted and following the completion of STOP bits TxD, enters in the mark state until $\overline{\text{CTS}}$ is asserted again. If the transmitter is forced to send a continuous low condition by issuing a Send-Break command, the transmitter ignores the state of $\overline{\text{CTS}}$.

You can program the transmitter to automatically negate the request-to-send ($\overline{\text{RTS}}$) output on completion of a message transmission. If the transmitter is programmed to operate in this mode, $\overline{\text{RTS}}$ must be manually asserted before a message is transmitted. In applications where the transmitter is disabled after transmission is complete and $\overline{\text{RTS}}$ is appropriately programmed, $\overline{\text{RTS}}$ is negated one bit time after the character in the shift register is completely transmitted. You must manually enable the transmitter by setting the enable-transmitter bit in the UART Command Register (UCR).

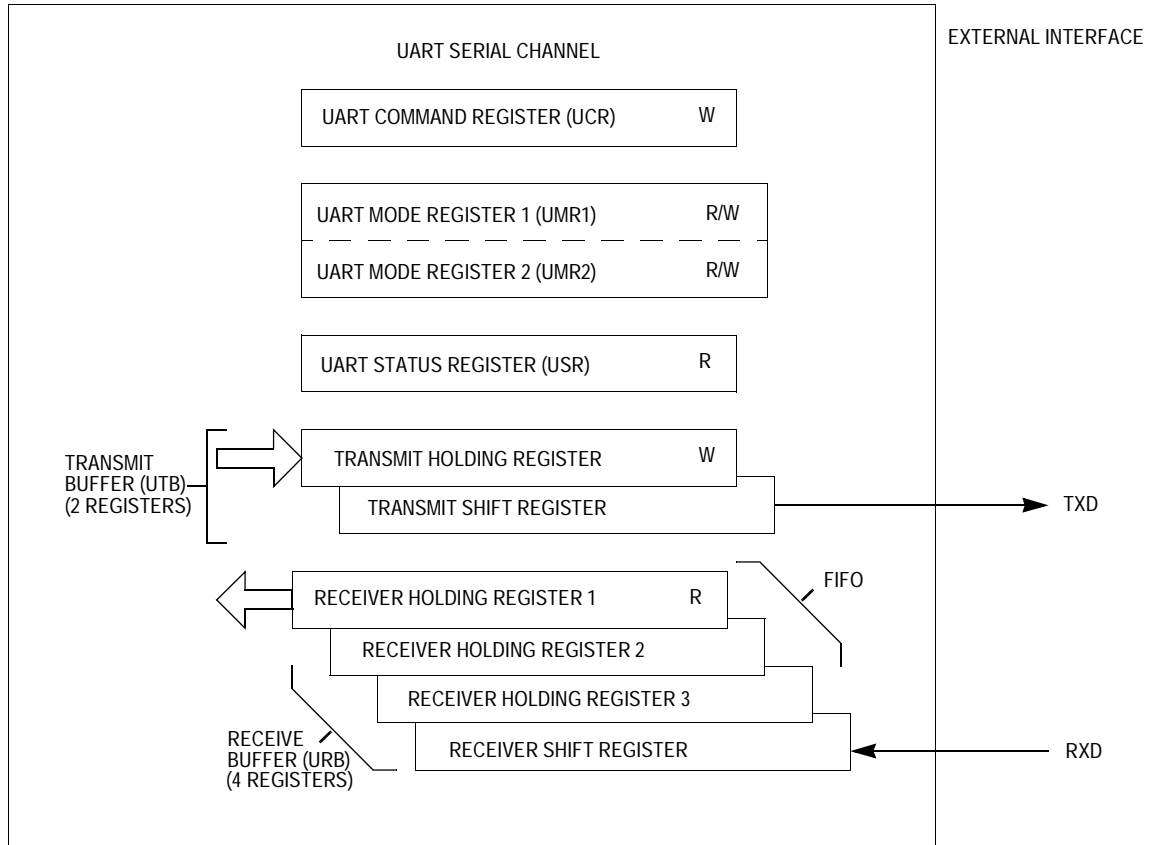
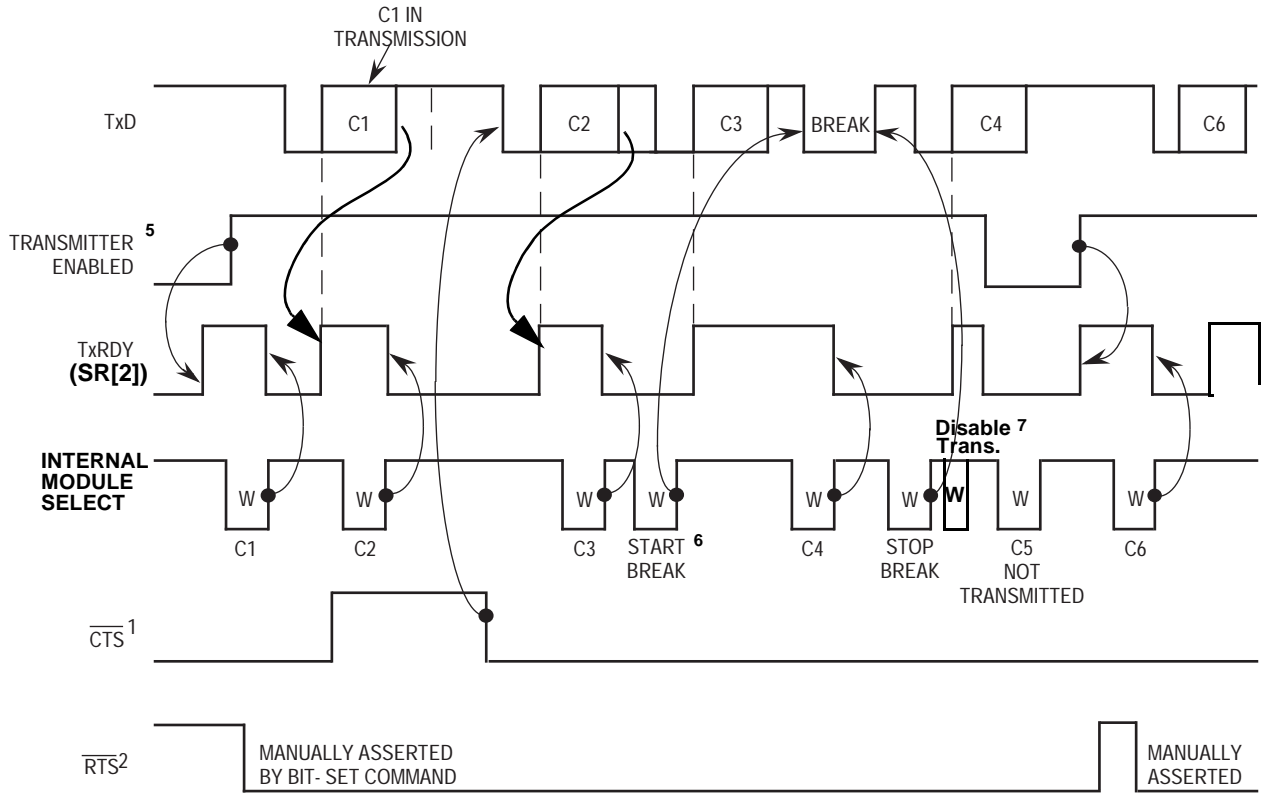

Figure 12-4. Transmitter and Receiver Functional Diagram



- Notes:
1. Timing shown for UMR2[4]=1
 2. Timing shown for UMR2[5]=1
 3. CN=Transmit 8-bit character
 4. W= Write
 5. Transmitter enabled by configuring TCx bits in UCR (see Table 11-9)
 6. Start break/Stop break programmed by MISCx bits in UCR (see Table 11-8)
 7. Transmitter is enabled and disabled using software control

Negated since transmit buffer and shift register are empty (last character has been shifted out)

Figure 12-5. Transmitter Timing Diagram

12.3.2.2 RECEIVER. The receiver is enabled through the UCR located within the UART module. Functional timing information for the receiver is shown in Figure 12-6. The receiver looks for a high-to-low (mark-to-space) transition of the start bit on RxD. When a transition is detected, the state of RxD is sampled each $16\times$ clock for eight clocks, starting one-half clock after the transition (asynchronous operation) or at the next rising edge of the bit time clock (synchronous operation). If RxD is sampled high, the start bit is not valid and the search for the valid start bit repeats. If RxD is still low, a valid start bit is assumed and the receiver continues to sample the input at one-bit time intervals at the theoretical center of the bit.

This process continues until the proper number of data bits and parity (if any) is assembled and one stop bit is detected. Data on the RxD input is sampled on the rising edge of the programmed clock source. The least significant bit is received first. The data is then transferred to a receiver holding register and the RxRDY bit in the USR is set. If the character length is less than eight bits, the most significant unused bits in the receiver holding register are cleared. The Rx RDY bit in the USR is set at the one-half point of the stop bit.

After the stop bit is detected, the receiver immediately looks for the next start bit. However, if a nonzero character is received without a stop bit (framing error) and RxD remains low for one-half of the bit period after the stop bit is sampled, the receiver operates as if a new start bit is detected. The parity error (PE), framing error (FE), overrun error (OE), and received break (RB) conditions (if any) set error and break flags in the USR at the received character boundary and are valid only when the RxRDY bit in the USR is set.

If a break condition is detected (RxD is low for the entire character including the stop bit), a character of all zeros is loaded into the receiver holding register and the Receive Break (RB) and RxRDY bits in the USR are set. The RxD signal must return to a high condition for at least one-half bit time before a search for the next start bit begins.

The receiver will detect the beginning of a break in the middle of a character if the break persists through the next character time. When the break begins in the middle of a character, the receiver places the damaged character in the receiver first-in-first-out (FIFO) stack and sets the corresponding error conditions and RxRDY bit in the USR. The break persists until the next character time, the receiver places an all-zero character into the receiver FIFO, and sets the corresponding RB and RxRDY bits in the USR. Interrupts can be enabled on receive break.

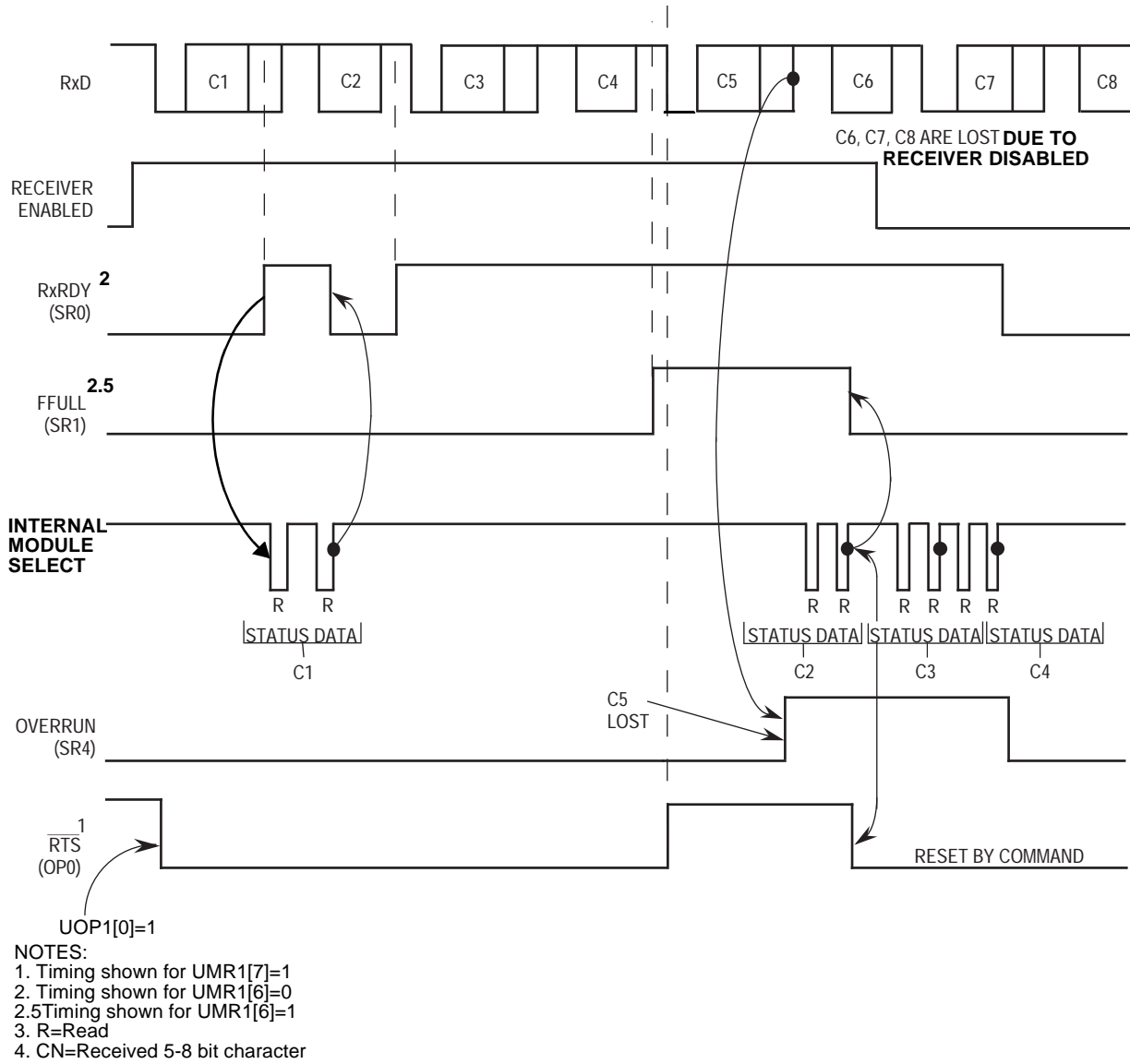

Figure 12-6. Receiver Timing Diagram

12.3.2.3 FIFO STACK. The FIFO stack is used in the UART receiver buffer logic. The FIFO stack consists of three receiver holding registers. The receive buffer consists of the FIFO and a receiver shift register connected to the RxD (refer to Figure 12-4). Data is assembled in the receiver shift register and loaded into the top empty receiver holding register position of the FIFO. Thus, data flowing from the receiver to the CPU is quadruple buffered.

In addition to the data byte, three status bits, parity error (PE), framing error (FE), and received break (RB) are appended to each data character in the FIFO; overrun error (OE) is not appended. By programming the error-mode bit (ERR) in the channel's mode register (UMR1), you can provide status in character or block modes.

The RxRDY bit in the USR is set whenever one or more characters are available to be read by the CPU. A read of the receiver buffer produces an output of data from the top of the FIFO stack. After the read cycle, the data at the top of the FIFO stack and its associated status bits are "popped," and the receiver shift register can add new data at the bottom of the stack. The FIFO-full status bit (FFULL) is set if all three stack positions are filled with data. Either the RxRDY or FFULL bit can be selected to cause an interrupt.

In the character mode, status provided in the USR is given on a character-by-character basis and thus applies only to the character at the top of the FIFO. In the block mode, the status provided in the USR is the logical OR of all characters coming to the top of the FIFO stack since the last reset error command. A continuous logical OR function of the corresponding status bits is produced in the USR as each character reaches the top of the FIFO stack.

The block mode is useful in applications where the software overhead of checking each character's error cannot be tolerated. In this mode, entire messages are received and only one data integrity check is performed at the end of the message. This mode has a data-reception speed advantage; however, each character is not individually checked for error conditions by software. If an error occurs within the message, the error is not recognized until the final check is performed, and no indication exists as to which message character is at fault.

In either mode, reading the USR does not affect the FIFO. The FIFO is popped only when the receive buffer is read. The USR should be read prior to reading the receive buffer. If all three of the FIFO receiver holding registers are full when a new character is received, the new character is held in the receiver shift register until a FIFO position is available. If an additional character is received during this state, the contents of the FIFO are not affected. However, the previous character in the receiver shift register is lost and the OE bit in the USR is set when the receiver detects the start bit of the new overrunning character.

To support control flow capability, you can program the receiver to automatically negate and assert \overline{RTS} . When in this mode, the receiver automatically negates \overline{RTS} when a valid start bit is detected and the FIFO stack is full. When a FIFO position becomes available,

the receiver asserts $\overline{\text{RTS}}$. Using this mode of operation prevents overrun errors by connecting the RTS to the CTS input of the transmitting device.

To use the $\overline{\text{RTS}}$ signals on UART 2, you must set up the MCF5206e Pin Assignment Register (PAR) in the SIM to enable the corresponding I/O pins for these functions. If the FIFO stack contains characters and the receiver is disabled, the CPU can still read the characters in the FIFO. If the receiver is reset, the FIFO stack and all receiver status bits, corresponding output ports, and interrupt request are reset. No additional characters are received until the receiver is re-enabled.

12.3.3 Looping Modes

You can configure the UART to operate in various looping modes as shown in Figure 12-7. These modes are useful for local and remote system diagnostic functions. The modes are described in the following paragraphs with additional information available in subsection **12.4 Register Description and Programming**.

You should only switch between modes while the transmitter and receiver are disabled because the selected mode is activated immediately on mode selection, even if this occurs in the middle of character transmission or reception. In addition, if a mode is deselected, the device switches out of the mode immediately, except for automatic echo and remote echo loopback modes. In these modes, the deselection occurs just after the receiver has sampled the stop bit (this is also the one-half point). For automatic echo mode, the transmitter stays in this mode until the entire stop bit has been retransmitted.

12.3.3.1 AUTOMATIC ECHO MODE. In this mode, the UART automatically retransmits the received data on a bit-by-bit basis. The local CPU-to-receiver communication continues normally but the CPU-to-transmitter link is disabled. While in this mode, received data is clocked on the receiver clock and retransmitted on TxD. The receiver must be enabled but not the transmitter. Instead, the transmitter is clocked by the receiver clock.

Because the transmitter is not active, the TxEMP and TxRDY bits in USR are inactive and data is transmitted as it is received. Received parity is checked but not recalculated for transmission. Character framing is also checked but stop bits are transmitted as received. A received break is echoed as received until the next valid start bit is detected.

12.3.3.2 LOCAL LOOPBACK MODE. In this mode, TxD is internally connected to RxD. This mode is useful for testing the operation of a local UART module channel by sending data to the transmitter and checking data assembled by the receiver. In this manner, correct channel operations can be assured. Both transmitter and CPU-to-receiver communications continue normally in this mode. While in this mode, the RxD input data is ignored, the TxD is held marking, and the receiver is clocked by the transmitter clock. The transmitter must be enabled but not the receiver.

12.3.3.3 REMOTE LOOPBACK MODE. In this mode, the channel automatically transmits received data on the TxD output on a bit-by-bit basis. The local CPU-to-

transmitter link is disabled. This mode is useful for testing remote channel receiver and transmitter operation. While in this mode, the receiver clocks the transmitter.

Because the receiver is not active, the CPU cannot read received data. All status conditions are inactive. Received parity is not checked and is not recalculated for transmission. Stop bits are transmitted as received. A received break is echoed as received until the next valid start bit is detected.

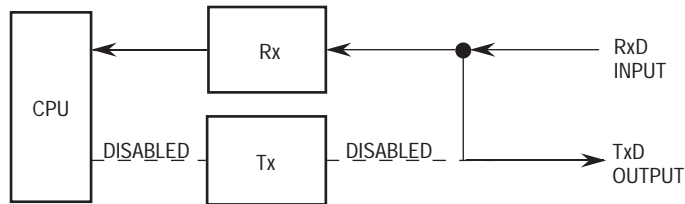

(a) Automatic Echo

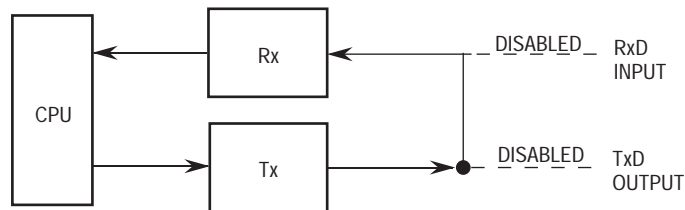

(b) Local Loopback

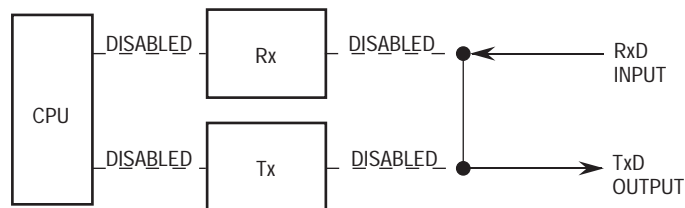

(c) Remote Loopback

Figure 12-7. Looping Modes Functional Diagram

12.3.4 Multidrop Mode

You can program the UART to operate in a wakeup mode for multidrop or multiprocessor applications. Functional timing information for the multidrop mode is shown in Figure 12-8. You select the mode by setting bits 3 and 4 in UART mode register 1 (UMR1). This mode of operation connects the master station to several slave stations (maximum of 256). In this mode, the master transmits an address character followed by a block of data characters targeted for one of the slave stations. The slave stations channel receivers are disabled; however, they continuously monitor the data stream sent out by the master station. When the master sends an address character, the slave receiver channel notifies its respective CPU by setting the RxRDY bit in the USR and generating an interrupt (if programmed to do so). Each slave station CPU then compares the received address to its station address and enables its receiver if it wants to receive the subsequent data characters or block of data from the master station. Slave stations not addressed continue to monitor the data stream for the next address character. Data fields in the data stream are separated by an address character. After a slave receives a block of data, the slave station CPU disables the receiver and reinitiates the process.

A transmitted character from the master station consists of a start bit, a programmed number of data bits, an address/data (A/D) bit flag, and a programmed number of stop bits. The A/D bit identifies the type of character being transmitted to the slave station. The character is interpreted as an address character if the A/D bit is set or as a data character if the A/D bit is cleared. You select the polarity of the A/D bit by programming bit 2 of UMR1. You should also program UMR1 before enabling the transmitter and loading the corresponding data bits into the transmit buffer.

In multidrop mode, the receiver continuously monitors the received data stream, regardless of whether it is enabled or disabled. If the receiver is disabled, it sets the RxRDY bit and loads the character into the receiver holding register FIFO stack, provided the received A/D bit is a one (address tag). The character is discarded if the received A/D bit is a zero (data tag). If the receiver is enabled, all received characters are transferred to the CPU via the receiver holding register stack during read operations.

In either case, the data bits are loaded into the data portion of the stack while the A/D bit is loaded into the status portion of the stack normally used for a parity error (USR bit 5). Framing error, overrun error, and break detection operate normally. The A/D bit takes the place of the parity bit; therefore, parity is neither calculated nor checked. Messages in this mode can still contain error detection and correction information. One way to provide error detection, if 8-bit characters are not required, is to use software to calculate parity and append it to the 5-, 6-, or 7-bit character.

12.3.5 Bus Operation

This subsection describes the operation of the bus during read, write, and interrupt-acknowledge cycles to the UART module. All UART module registers must be accessed as bytes.

12.3.5.1 READ CYCLES. The CPU with zero wait states accesses the UART module because the MCF5206e system clock is also used for the UART module. The UART module responds to reads with byte data on D[7:0]. Reserved registers return logic zero during reads.

12.3.5.2 WRITE CYCLES. The CPU with zero wait states accesses the UART module. The UART module accepts write data on D[7:0]. Write cycles to read-only registers and reserved registers complete in a normal manner without exception processing; however, the data is ignored.

12.3.5.3 INTERRUPT ACKNOWLEDGE CYCLES. The UART module can arbitrate for interrupt servicing and supply the interrupt vector when it has successfully won arbitration. The vector number must be provided if interrupt servicing is necessary; thus, the interrupt vector register (UIVR) must be initialized. The interrupt vector number generated by the IVR is used if the autovector is not enabled in the SIM Interrupt Control Register (ICR). If the UIVR is not initialized and the ICR is not programmed for autovector, a spurious interrupt exception is taken if interrupts are generated. This works in conjunction with the MCF5206e interrupt controller, which allows a programmable Interrupt Priority Level (IPL) for the interrupt.

12.4 REGISTER DESCRIPTION AND PROGRAMMING

This subsection contains a detailed description of each register and its specific function as well as flowcharts of basic UART module programming.

12.4.1 Register Description

Writing control bytes into the appropriate registers controls the UART operation. A list of UART module registers and their associated addresses is shown in Table 12-1.

NOTE

All UART module registers are accessible only as bytes. You should change the contents of the mode registers (UMR1 and UMR2), clock-select register (UCSR), and the auxiliary control register (UACR) bit 7 only after the receiver/transmitter is issued a software RESET command—i.e., channel operation must be disabled. You should be careful if the register contents are changed during receiver/transmitter operations as unpredictable results can occur.

For the registers discussed in the following pages, the numbers above the register description represent the bit position in the register. The register description contains the

mnemonic for the bit. The values shown below the register description are the values of those register bits after a hardware reset. A value of U indicates that the bit value is unaffected by reset. The read/write status is shown in the last line.

Table 12-1. UART Module Programming Model

UART 1	UART 2	REGISTER READ (R/W = 1)	REGISTER WRITE (R/W = 0)
MBAR+\$140	MBAR+\$180	Mode Register (UMR1, UMR2)	Mode Register (UMR1, UMR2)
MBAR+\$144	MBAR+\$184	Status Register (USR)	Clock-Select Register (UCSR)
MBAR+\$148	MBAR+\$188	DO NOT ACCESS ¹	Command Register (UCR)
MBAR+\$14C	MBAR+\$18C	Receiver Buffer (URB)	Transmitter Buffer (UTB)
MBAR+\$150	MBAR+\$190	Input Port Change Register (UIPCR)	Auxiliary Control Register (UACR)
MBAR+\$154	MBAR+\$194	Interrupt Status Register (UISR)	Interrupt Mask Register (UIMR)
MBAR+\$158	MBAR+\$198	Baud Rate Generator Prescale MSB (UBG1)	Baud Rate Generator Prescale MSB (UBG1)
MBAR+\$15C	MBAR+\$19C	Baud Rate Generator Prescale LSB (UBG2)	Baud Rate Generator Prescale LSB (UBG2)
		DO NOT ACCESS ¹	
MBAR+\$170	MBAR+\$1B0	Interrupt Vector Register (UIVR)	Interrupt Vector Register (UIVR)
MBAR+\$174	MBAR+\$1B4	Input Port Register (UIP)	DO NOT ACCESS ¹
MBAR+\$178	MBAR+\$1B8	DO NOT ACCESS ¹	Output Port Bit Set CMD (UOP1) ²
MBAR+\$17C	MBAR+\$1BC	DO NOT ACCESS ¹	Output Port Bit Reset CMD (UOP0) ²

- NOTES: 1. This address is used for factory testing and should not be read. Reading this location results in undesired effects and possible incorrect transmission or reception of characters. Register contents can also be changed.
 2. Address-triggered commands.

12.4.1.1 MODE REGISTER 1 (UMR1). UMR1 controls some of the UART module configuration. This register can be read or written at any time and is accessed when the mode register pointer points to UMR1. The pointer is set to UMR1 by RESET or by a set pointer command using the control register. After reading or writing UMR1, the pointer points to UMR2.

UMR1				MBAR + \$140, MBAR+\$180			
7	6	5	4	3	2	1	0
RXRT S	RXIRQ	ERR	PM1	PM0	PT	B/C1	B/C0
RESET							
0	0	0	0	0	0	0	0
READ/WRITE				SUPERVISOR OR USER			

RxRTS — Receiver Request-to-Send Control

- 1 = On receipt of a valid start bit, \overline{RTS} is negated if the UART FIFO is full. \overline{RTS} is reasserted when the FIFO has an empty position available.
- 0 = The receiver has no effect on \overline{RTS} . The RTS is asserted by writing a one to the Output Port Bit Set Register (UOP1)

You can use this feature for flow control to prevent overrun in the receiver by using the RTS output to control the CTS input of the transmitting device. If both the receiver and transmitter are programmed for RTS control, RTS control is disabled for both because such a configuration is incorrect. See **Section 12.4.1.2 Mode Register 2 (UMR2)** for information on programming the transmitter RTS control. On UART 2, RTS is muxed.

RxIRQ — Receiver Interrupt Select

- 1 = FFULL is the source that generates IRQ
- 0 = RxRDY is the source that generates IRQ

ERR — Error Mode

This bit controls the meaning of the three FIFO status bits (RB, FE, and PE) in the USR.

- 1 = Block mode—The values in the channel USR are the accumulation (i.e., the logical OR) of the status for all characters coming to the top of the FIFO since the last reset error status command for the channel was issued. Refer to **Section 12.4.1.5 Command Register (UCR)** for more information on UART module commands.
- 0 = Character mode—The values in the channel USR reflect the status of the character at the top of the FIFO.

NOTE

You must use ERR = 0 to obtain the correct A/D flag information when in multidrop mode.

PM1–PM0 — Parity Mode

These bits encode the type of parity used for the channel (see Table 12-2). The parity bit is added to the transmitted character and the receiver performs a parity check on incoming data. These bits can alternatively select multidrop mode for the channel.

PT — Parity Type

This bit selects the parity type if parity is programmed by the parity mode bits; if multidrop mode is selected, it configures the transmitter for data character transmission or address character transmission. Table 12-2 lists the parity mode and type or the multidrop mode for each combination of the parity mode and the parity type bits.

Table 12-2. PMx and PT Control Bits

PM1	PM0	PARITY MODE	PT	PARITY TYPE
0	0	With Parity	0	Even Parity
0	0	With Parity	1	Odd Parity
0	1	Force Parity	0	Low Parity
0	1	Force Parity	1	High Parity
1	0	No Parity	X	No Parity
1	1	Multidrop Mode	0	Data Character
1	1	Multidrop Mode	1	Address Character

“Force parity low” means forcing a 0 parity bit. “Force parity high” forces a 1 parity bit.

B/C1–B/C0 — Bits per Character

These bits select the number of data bits per character to be transmitted. The character length listed in Table 12-3 does not include start, parity, or stop bits.

Table 12-3. B/Cx Control Bits

B/C1	B/C0	BITS/CHARACTER
0	0	5 Bits
0	1	6 Bits
1	0	7 Bits
1	1	8 Bits

12.4.1.2 MODE REGISTER 2 (UMR2). UMR2 controls some of the UART module configuration. It is accessed when the mode register pointer points to UMR2, which occurs after any access to UMR1. Accesses to UMR2 do not change the pointer.

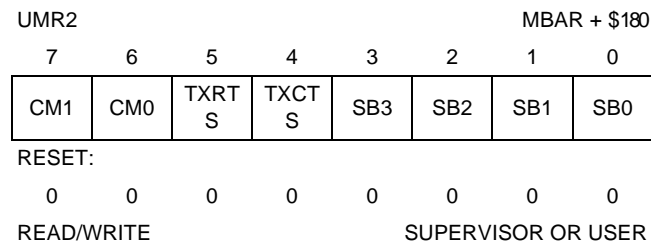

CM1–CM0 — Channel Mode

These bits select a channel mode as listed in Table 12-4. See **Section 12.3.3 Looping Modes** for more information on the individual modes.

Table 12-4. CMx Control Bits

CM1	CM0	MODE
0	0	Normal
0	1	Automatic Echo
1	0	Local Loopback
1	1	Remote Loopback

TxRTS — Transmitter Ready-to-Send

This bit controls the negation of the $\overline{\text{RTS}}$ signal.

In applications where the transmitter is disabled after transmission is complete, setting this bit causes the OP bit to be cleared automatically one bit time after the characters (if any) in the channel transmit shift register and the transmitter holding register are completely transmitted, including the programmed number of stop bits. This feature automatically terminates message transmission. You can perform this process by following these steps:

1. Program the UART for the automatic-reset mode: UMR2[5]=1
2. Enable the transmitter
3. Assert the transmitter request-to send control: UOP1[0]=1
4. Send the message
5. Disable the transmitter after the TxRDY bit but not the TxEMP bit in the USR becomes asserted.

The last character will be transmitted and the UOP0[0] bit will be set causing the transmitter request-to-send control to be negated.

If both the receiver and the transmitter in the same channel are programmed for $\overline{\text{RTS}}$ control, $\overline{\text{RTS}}$ control is disabled for both because of this incorrect configuration.

- 1 = If both TxRDY and TXEMP bits in the UART Status Register (USR) are set, there will be no change on $\overline{\text{RTS}}$. For TXRTS to be set to 1 in this condition, customers must set the UART Output Port Set Data Register (UOP1).
- 0 = The transmitter has no effect on $\overline{\text{RTS}}$.

TxCTS — Transmitter Clear-to-Send

- 1 = Enables clear-to-send operation. The transmitter checks the state of the $\overline{\text{CTS}}$ input each time it is ready to send a character. If $\overline{\text{CTS}}$ is asserted, the character is transmitted. If $\overline{\text{CTS}}$

Table 12-5. SBx Control Bits

SB3	SB2	SB1	SB0	LENGTH 6-8 BITS	LENGTH 5 BITS
0	0	0	0	0.563	1.063
0	0	0	1	0.625	1.125
0	0	1	0	0.688	1.188
0	0	1	1	0.750	1.250
0	1	0	0	0.813	1.313
0	1	0	1	0.875	1.375
0	1	1	0	0.938	1.438
0	1	1	1	1.000	1.500
1	0	0	0	1.563	1.563
1	0	0	1	1.625	1.625
1	0	1	0	1.688	1.688
1	0	1	1	1.750	1.750
1	1	0	0	1.813	1.813
1	1	0	1	1.875	1.875
1	1	1	0	1.938	1.938
1	1	1	1	2.000	2.000

12.4.1.3 STATUS REGISTER (USR). The USR indicates the status of the characters in the receive FIFO and the status of the transmitter and receiver. The RB, FE, and PE bits

USR				MBAR + \$184			
7	6	5	4	3	2	1	0
RB	FE	PE	OE	TXEMP	TXRDY	FFULL	RXRDY
RESET:							
0	0	0	0	0	0	0	0
READ ONLY				SUPERVISOR OR USER			

are cleared by the Reset Error Status command in the UCR if the RB bit has not been read. Also, RB, FE, PE and OE can also be cleared by reading the Receive buffer (RE).

RB — Received Break

1 = An all-zero character of the programmed length has been received without a stop bit. The RB bit is valid only when the RxRDY bit is set. A single FIFO position is occupied when a break is received. Additional entries into the FIFO are inhibited until RxRDY returns to the high state for at least one-half bit time, which is equal to two successive edges of the internal or external clock x 1 or 16 successive edges of the external clock x 16. The received break circuit detects breaks that originate in the middle of a received character. However, if a break begins in the middle of a character, it must persist until the end of the next detected character time.

0 = No break has been received.

FE — Framing Error

- 1 = A stop bit was not detected when the corresponding data character in the FIFO was received. The stop-bit check occurs in the middle of the first stop-bit position. The bit is valid only when the RxRDY bit is set.
- 0 = No framing error has occurred.

PE — Parity Error

- 1 = When the with-parity or force-parity mode is programmed in the UMR1, the corresponding character in the FIFO was received with incorrect parity. When the multidrop mode is programmed, this bit stores the received A/D bit. This bit is valid only when the RxRDY bit is set.
- 0 = No parity error has occurred.

OE — Overrun Error

- 1 = One or more characters in the received data stream have been lost. This bit is set on receipt of a new character when the FIFO is full and a character is already in the shift register waiting for an empty FIFO position. When this occurs, the character in the receiver-shift register and its break-detect, framing-error status, and parity error, if any, are lost. The reset-error status command in the UCR clears this bit.
- 0 = No overrun has occurred.

TxEEMP — Transmitter Empty

- 1 = The transmitter has underrun (both the transmitter holding register and transmitter shift registers are empty). This bit is set after transmission of the last stop bit of a character if there are no characters in the transmitter-holding register awaiting transmission.
- 0 = The transmitter buffer is not empty. Either a character is currently being shifted out or the transmitter is disabled. You can enable/disable the transmitter by programming the TCx bits in the UCR.

TxRDY — Transmitter Ready

- 1 = The transmitter-holding register is empty and ready to be loaded with a character. This bit is set when the character is transferred to the transmitter shift register. This bit is also set when the transmitter is first enabled. Characters loaded into the transmitter holding register while the transmitter is disabled are not transmitted.
- 0 = The CPU has loaded the transmitter-holding register or the transmitter is disabled.

FFULL — FIFO Full

- 1 = Three characters have been received and are waiting in the receiver buffer FIFO.
- 0 = The FIFO is not full but can contain as many as two unread characters.

RxRDY — Receiver Ready

- 1 = One or more characters have been received and are waiting in the receiver buffer FIFO.
- 0 = The CPU has read the receiver buffer and no characters remain in the FIFO after this read.

12.4.1.4 CLOCK-SELECT REGISTER (UCSR). The UCSR selects the internal clock (timer mode) or the external clock in synchronous or asynchronous mode. To use the timer mode for either the receiver and transmitter channel, program the UCSR to the value \$DD. The transmitter and receiver can be programmed to different clock sources.

UCSR				MBAR + \$184			
7	6	5	4	3	2	1	0
RCS3	RCS2	RCS1	RCS0	TCS3	TCS2	TCS1	TCS0
RESET:							
1	1	0	1	1	1	0	1
WRITE ONLY				SUPERVISOR OR USER			

RCS3–RCS0 — Receiver Clock Select

These bits select the clock source for the receiver channel. Table 12-6 details the register bits necessary for each mode.

Table 12-6. RCSx Control Bits

RCS3	RCS2	RCS1	RCS0	MODE
1	1	0	1	TIMER
1	1	1	0	Ext. clk. x 16
1	1	1	1	Ext. clk. x 1

TCS3–TCS0 — Transmitter Clock Select

These bits determine the clock source of the UART transmitter channel.

Table 12-7. TCSx Control Bits

TCS3	TCS2	TCS1	TCS0	SET 1
1	1	0	1	TIMER
1	1	1	0	Ext. clk. x 16
1	1	1	1	Ext. clk. x 1

12.4.1.5 COMMAND REGISTER (UCR). The UCR supplies commands to the UART. You can specify multiple commands in a single write to the UCR if the commands are not conflicting – e.g., reset-transmitter and enable-transmitter commands cannot be specified in a single command.

UCR				MBAR + \$188			
7	6	5	4	3	2	1	0
—	MISC2	MISC1	MISC0	TC1	TC0	RC1	RC0
RESET:							
0	0	0	0	0	0	0	0
WRITE ONLY				SUPERVISOR OR USER			

MISC3–MISC0 — Miscellaneous Commands

These bits select a single command as listed in Table 12-8.

Table 12-8. MISCx Control Bits

MISC2	MISC1	MISC0	COMMAND
0	0	0	No Command
0	0	1	Reset Mode Register Pointer
0	1	0	Reset Receiver
0	1	1	Reset Transmitter
1	0	0	Reset Error Status
1	0	1	Reset Break-Change Interrupt
1	1	0	Start Break
1	1	1	Stop Break

The commands are described as follows:

Reset Mode Register Pointer

The reset mode register pointer command causes the mode register pointer to point to UMR1.

Reset Receiver

The reset receiver command resets the receiver. The receiver is immediately disabled, the FFULL and RxRDY bits in the USR are cleared, and the receiver FIFO pointer is reinitialized. All other registers are unaltered. Use this command instead of the receiver-disable command whenever the receiver configuration is changed (it places the receiver in a known state).

Reset Transmitter

The reset transmitter command resets the transmitter. The transmitter is immediately disabled and the TxEMP and TxRDY bits in the USR are cleared. All other registers are unaltered. Use this command instead of the transmitter-disable command whenever the transmitter configuration is changed (it places the transmitter in a known state).

Reset Error Status

The reset error status command clears the RB, FE, PE, and OE bits in the USR. This command is also used in the block mode to clear all error bits after a data block is received.

Reset Break-Change Interrupt

The reset break-change interrupt command clears the delta break (DBx) bit in the UISR.

Start Break

The start break command forces TxD low. If the transmitter is empty, the start of the break conditions can be delayed by as much as two bit times. If the transmitter is active, the break begins when transmission of the character is complete. If a character is in the transmitter shift register, the start of the break is delayed until the character is transmitted. If the transmitter holding register has a character, that character is transmitted before the break. The transmitter must be enabled for this command to be accepted. The state of the CTS input is ignored for this command.

Stop Break

The stop break command causes TxD to go high (mark) within two bit times. Characters stored in the transmitter buffer, if any, are transmitted.

TC1–TC0 — Transmitter Commands

These bits select a single command as listed in Table 12-9.

Table 12-9. TCx Control Bits

TC1	TC0	COMMAND
0	0	No Action Taken
0	1	Transmitter Enable
1	0	Transmitter Disable
1	1	Do Not Use

The definitions of the transmitter command options are as follows:

No Action Taken

The “no action taken” command causes the transmitter to stay in its current mode. If the transmitter is enabled, it remains enabled; if disabled, it remains disabled.

Transmitter Enable

The “transmitter enable” command enables operation of the channel's transmitter. The TxEMP and TxRDY bits in the USR are also set. If the transmitter is already enabled, this command has no effect.

Transmitter Disable

The “transmitter disable” command terminates transmitter operation and clears the TxEMP and TxRDY bits in the USR. However, if a character is being transmitted when the transmitter is disabled, the transmission of the character is completed before the transmitter becomes inactive. If the transmitter is already disabled, this command has no effect.

Do Not Use

Do not use this bit combination because the result is indeterminate.

RC1–RC0 — Receiver Commands

These bits select a single command as listed in Table 12-10.

Table 12-10. RCx Control Bits

RC1	RC0	COMMAND
0	0	No Action Taken
0	1	Receiver Enable
1	0	Receiver Disable
1	1	Do Not Use

No Action Taken

The “no action taken” command causes the receiver to stay in its current mode. If the receiver is enabled, it remains enabled; if disabled, it remains disabled.

Receiver Enable

The “receiver enable” command enables operation of the channel's receiver. If the UART module is not in multidrop mode, this command also forces the receiver into the search-for-start-bit state. If the receiver is already enabled, this command has no effect.

Receiver Disable

The “receiver disable” command immediately disables the receiver. Any character being received is lost. The command has no effect on the receiver status bits or any other control register. If the UART module is programmed to operate in the local loopback mode or multidrop mode, the receiver operates even though this command is selected. If the receiver is already disabled, this command has no effect.

Do Not Use

Do not use this bit combination because the result is indeterminate.

12.4.1.6 RECEIVER BUFFER (URB). The receiver buffer contains three receiver-holding registers and a serial shift register. The RxD pin is connected to the serial shift register while the holding registers act as a FIFO. The CPU reads from the top of the stack

while the receiver shifts and updates from the bottom of the stack when the shift register has been filled (see Figure 12-4).

URB				MBAR + \$18C			
7	6	5	4	3	2	1	0
RB7	RB6	RB5	RB4	RB3	RB2	RB1	RB0
RESET:							
1	1	1	1	1	1	1	1
READ ONLY				SUPERVISOR OR USER			

RB7–RB0 — These bits contain the character in the receiver buffer.

12.4.1.7 TRANSMITTER BUFFER (UTB). The transmitter buffer consists of two registers: the transmitter-holding register and the transmitter shift register (see Figure 12-4). The holding register accepts characters from the bus master if the TxRDY bit in the channel's USR is set. A write to the transmitter buffer clears the TxRDY bit, inhibiting additional characters until the shift register is ready to accept more data. When the shift register is empty, it checks the holding register for a valid character to be sent (TxRDY bit cleared). If a valid character is present, the shift register loads the character and reasserts the TxRDY bit in the USR. Writes to the transmitter buffer when the channel's UART Status Register (USR) TxRDY bit is clear and when the transmitter is disabled have no effect on the transmitter buffer.

UTB				MBAR + \$18C			
7	6	5	4	3	2	1	0
TB7	TB6	TB5	TB4	TB3	TB2	TB1	TB0
RESET:							
0	0	0	0	0	0	0	0
WRITE ONLY				SUPERVISOR OR USER			

TB7–TB0 — These bits contain the character in the transmitter buffer.

12.4.1.8 INPUT PORT CHANGE REGISTER (UIPCR). The UIPCR shows the current state and the change-of-state for the $\overline{\text{CTS}}$ pin.

UIPCR				MBAR + \$190			
7	6	5	4	3	2	1	0
0	0	0	COS	1	1	1	CTS
RESET:							
0	0	0	0	1	1	1	1
READ ONLY				SUPERVISOR OR USER			

Bits 7, 6, 5, 3, 2, 1 — Reserved by Motorola.

COS — Change-of-State

- 1 = A change-of-state (high-to-low or low-to-high transition), lasting longer than 25–50 μ s has occurred at the $\overline{\text{CTS}}$ input. When this bit is set, you can program the UART Auxiliary Control Register (UACR) to generate an interrupt to the CPU.
- 0 = No change-of-state has occurred since the last time the CPU read the UART Input Port Change Register (UIPCR). A read of the UIPCR also clears the UART Interrupt Status Register (UISR)COS bit.

$\overline{\text{CTS}}$ — Current State

Starting two serial clock periods after reset, the $\overline{\text{CTS}}$ bit reflects the state of the $\overline{\text{CTS}}$ pin. If the $\overline{\text{CTS}}$ pin is detected as asserted at that time, the COS bit is set, which initiates an interrupt if the Input Enable Control (IEC) bit of the UACR register is enabled.

- 1 = The current state of the $\overline{\text{CTS}}$ input is logic one.
- 0 = The current state of the $\overline{\text{CTS}}$ input is logic zero.

12.4.1.9 AUXILIARY CONTROL REGISTER (UACR).

UACR						MBAR + \$190	
7	6	5	4	3	2	1	0
-	-	-	-	-	-	-	IEC
RESET:							
0	0	0	0	0	0	0	0
WRITE ONLY				SUPERVISOR OR USER			

IEC — Input Enable Control

- 1 = UISR bit 7 is set and generates an interrupt when the COS bit in the UART Input Port Change Register (UIPCR) is set by an external transition on the $\overline{\text{CTS}}$ input (if bit 7 of the interrupt mask register (UIMR) is set to enable interrupts).
- 0 = Setting the corresponding bit in the UIPCR has no effect on UISR bit 7.

12.4.1.10 INTERRUPT STATUS REGISTER (UISR). The UISR provides enables for all potential interrupt sources. The UART Interrupt Mask Register (UIMR) masks the contents of this register. If a flag in the UISR is set and the corresponding bit in UIMR is also set, the internal interrupt output is asserted. If the corresponding bit in the UIMR is cleared, the state of the bit in the UISR has no effect on the interrupt output.

NOTE

The UIMR does not mask reading of the UISR. True status is provided regardless of the contents of UIMR. A UART module reset clears the contents of UISR.

UISR					MBAR + \$194		
7	6	5	4	3	2	1	0
COS	—	—	—	—	DB	RxRDY	TxRDY
RESET:							
0	0	0	0	0	0	0	0
READ ONLY					SUPERVISOR OR USER		

COS — Change-of-State

- 1 = A change-of-state has occurred at the $\overline{\text{CTS}}$ input and has been selected to cause an interrupt by programming bit 0 of the UACR.
- 0 = COS bit in the UIPCR is not selected.

DB — Delta Break

- 1 = The receiver has detected the beginning or end of a received break.
- 0 = No new break-change condition to report. Refer to **Section 12.4.1.5 Command Register (UCR)** for more information on the reset break-change interrupt command.

RxRDY — Receiver Ready or FIFO Full

UMR1 bit 6 programs the function of this bit. It is a duplicate of either the FFULL or RxRDY bit of USR.

TxRDY — Transmitter Ready

This bit is the duplication of the TxRDY bit in USR.

- 1 = The transmitter holding register is empty and ready to be loaded with a character.
- 0 = The CPU loads the transmitter-holding register or the transmitter is disabled. Characters loaded into the transmitter-holding register when TxRDY=0 are not transmitted.

12.4.1.11 INTERRUPT MASK REGISTER (UIMR). The UIMR selects the corresponding bits in the UISR that cause an interrupt. By setting the bit, the interrupt is enabled. If one of the bits in the UISR is set and the corresponding bit in the UIMR is also set, the internal interrupt output is asserted. If the corresponding bit in the UIMR is zero,

the state of the bit in the UISR has no effect on the interrupt output. The UIMR does not mask the reading of the UISR.

UIMR					MBAR + \$194		
7	6	5	4	3	2	1	0
COS	—	—	—	—	DB	FFULL	TXRDY
RESET:							
0	0	0	0	0	0	0	0
WRITE ONLY					SUPERVISOR OR USER		

COS — Change-of-State

- 1 = Enable interrupt
- 0 = Disable interrupt

DB — Delta Break

- 1 = Enable interrupt
- 0 = Disable interrupt

FFULL — FIFO Full

- 1 = Enable interrupt
- 0 = Disable interrupt

TxRDY — Transmitter Ready

- 1 = Enable interrupt
- 0 = Disable interrupt

12.4.1.12 TIMER UPPER PRELOAD REGISTER 1 (UBG1). This register holds the eight most significant bits of the preload value the timer uses for providing a given baud rate. The minimum value that can be loaded on the concatenation of UBG1 with UBG2 is \$0002. This register is write only and cannot be read by the CPU.

12.4.1.13 TIMER UPPER PRELOAD REGISTER 2 (UBG2). This register holds the eight least significant bits of the preload value the timer uses for providing a given baud rate. The minimum value that can be loaded on the concatenation of UBG1 with UBG2 is \$0002. This register is write only and cannot be read by the CPU.

12.4.1.14 INTERRUPT VECTOR REGISTER (UIVR). The UIVR contains the 8-bit vector number of the internal interrupt.

UIVR								MBAR + \$1B0	
7	6	5	4	3	2	1	0		
IVR7	IVR6	IVR5	IVR4	IVR3	IVR2	IVR1	IVR0		
RESET:									
0	0	0	0	1	1	1	1		
READ/WRITE					SUPERVISOR OR USER				

IVR7–IVR0 — Interrupt Vector Bits

This 8-bit number indicates the offset from the base of the vector table where the address of the exception handler for the specified interrupt is located. The UIVR is reset to \$0F, which indicates an uninitialized interrupt condition.

12.4.1.14.1 Input Port Register (UIP). The UIP register shows the current state of the CTS input.

UIP						MBAR + \$1B4	
7	6	5	4	3	2	1	0
—	—	—	—	—	—	—	CTS
RESET:							
1	1	1	1	1	1	1	1
READ ONLY						SUPERVISOR OR USER	

$\overline{\text{CTS}}$ — Current State

- 1 = The current state of the $\overline{\text{CTS}}$ input is logic one.
- 0 = The current state of the $\overline{\text{CTS}}$ input is logic zero.

The information contained in this bit is latched and reflects the state of the input pin at the time that the UIP is read.

NOTE

This bit has the same function and value as the UIPCR bit 0.

12.4.1.14.2 Output Port Data Registers (UOP1, UOP0). The $\overline{\text{RTS}}$ output is set by a bit set command (writing to UOP1) and is cleared by a bit reset command (writing to UOP0).

UOP1						MBAR + \$148	
7	6	5	4	3	2	1	0
							RTS
RESET:							
—	—	—	—	—	—	—	0
WRITE ONLY						SUPERVISOR OR USER	

$\overline{\text{RTS}}$ — Output Port Parallel Output

- 1 = A write cycle to the OPset address asserts the $\overline{\text{RTS}}$ signal.
- 0 = This bit is not affected by writing a zero to this address.

NOTE

The output port bits are inverted at the pins so the $\overline{\text{RTS}}$ set bit provides an asserted $\overline{\text{RTS}}$ pin.

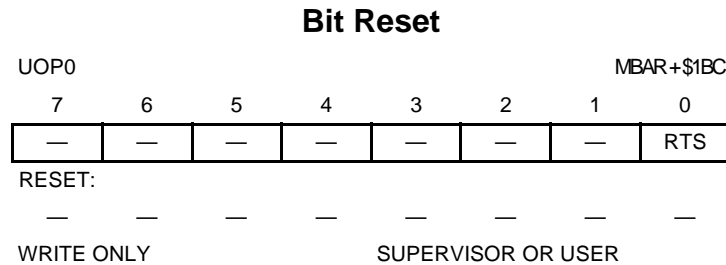

$\overline{\text{RTS}}$ — Output Port Parallel Output

- 1 = A write cycle to the OP bit reset address negates $\overline{\text{RTS}}$.
- 0 = This bit is not affected by writing a zero to this address.

12.4.2 Programming

Figure 11-9 shows the basic interface software flowchart required for operation of the UART module. The routines are divided into these three categories:

1. UART Module Initialization
2. I/O Driver
3. Interrupt Handling

12.4.2.1 UART MODULE INITIALIZATION. The UART module initialization routines consist of SINIT and CHCHK. SINIT is called at system initialization time to check UART operation. Before SINIT is called, the calling routine allocates two words on the system stack. On return to the calling routine, SINIT passes information on the system stack to reflect the status of the UART. If SINIT finds no errors, the receiver and transmitter are enabled. The CHCHK routine performs the actual checks as called from the SINIT routine. When called, SINIT places the UART in the local loopback mode and checks for the following errors:

- Transmitter Never Ready
- Receiver Never Ready
- Parity Error
- Incorrect Character Received

12.4.2.2 I/O DRIVER EXAMPLE. The I/O driver routines consist of INCH and OUTCH. INCH is the terminal input character routine and obtains a character from the receiver. OUTCH is sends a character to the transmitter.

12.4.2.3 INTERRUPT HANDLING. The interrupt-handling routine consists of SIRQ, which is executed after the UART module generates an interrupt caused by a change in break (beginning of a break). SIRQ then clears the interrupt source, waits for the next change-in-break interrupt (end of break), clears the interrupt source again, then returns from exception processing to the system monitor.

12.5 UART MODULE INITIALIZATION SEQUENCE

The following steps are required to properly initialize the UART module:

Command Register (UCR)

1. Reset the receiver and transmitter.
2. Program the vector number for a UART module interrupt. However, if the UART Interrupt Control Register (ICR_U1) is programmed to generate an autovector, the UART Interrupt Vector Register (UIVR) must be programmed with an autovector number.

Interrupt Mask Register (UIMR)

1. Enable the desired interrupt sources.

Auxiliary Control Register (UACR)

1. Initialize the Input Enable Control (IEC) bit.
2. Select timer mode and clock source, if necessary.

Clock Select Register (UCSR)

1. Select the receiver and transmitter clock. Use timer as source, if required.

Mode Register 1 (UMR1)

1. If required, program operation of Receiver Ready-to-Send (RxRTS Bit).
2. Select Receiver-Ready or FIFO-Full Notification (R/F Bit).
3. Select character or block-error mode (ERR Bit).
4. Select parity mode and type (PM and PT Bits).
5. Select number of bits per character (B/Cx Bits).

Mode Register 2 (UMR2)

1. Select the mode of operation (CMx bits).
2. If required, program operation of Transmitter Ready-to-Send (TxRTS Bit).
3. If required, program operation of Clear-to-Send (TxCTS Bit).
4. Select stop-bit length (SBx Bits).

Command Register (UCR)

Enable the receiver and transmitter.

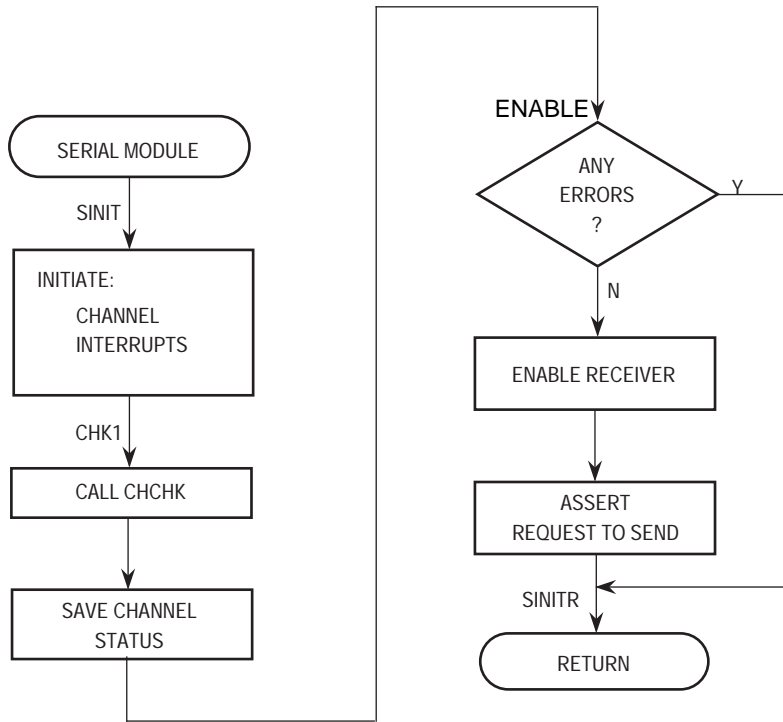

Figure 11-9. UART Software Flowchart (1 of 5)

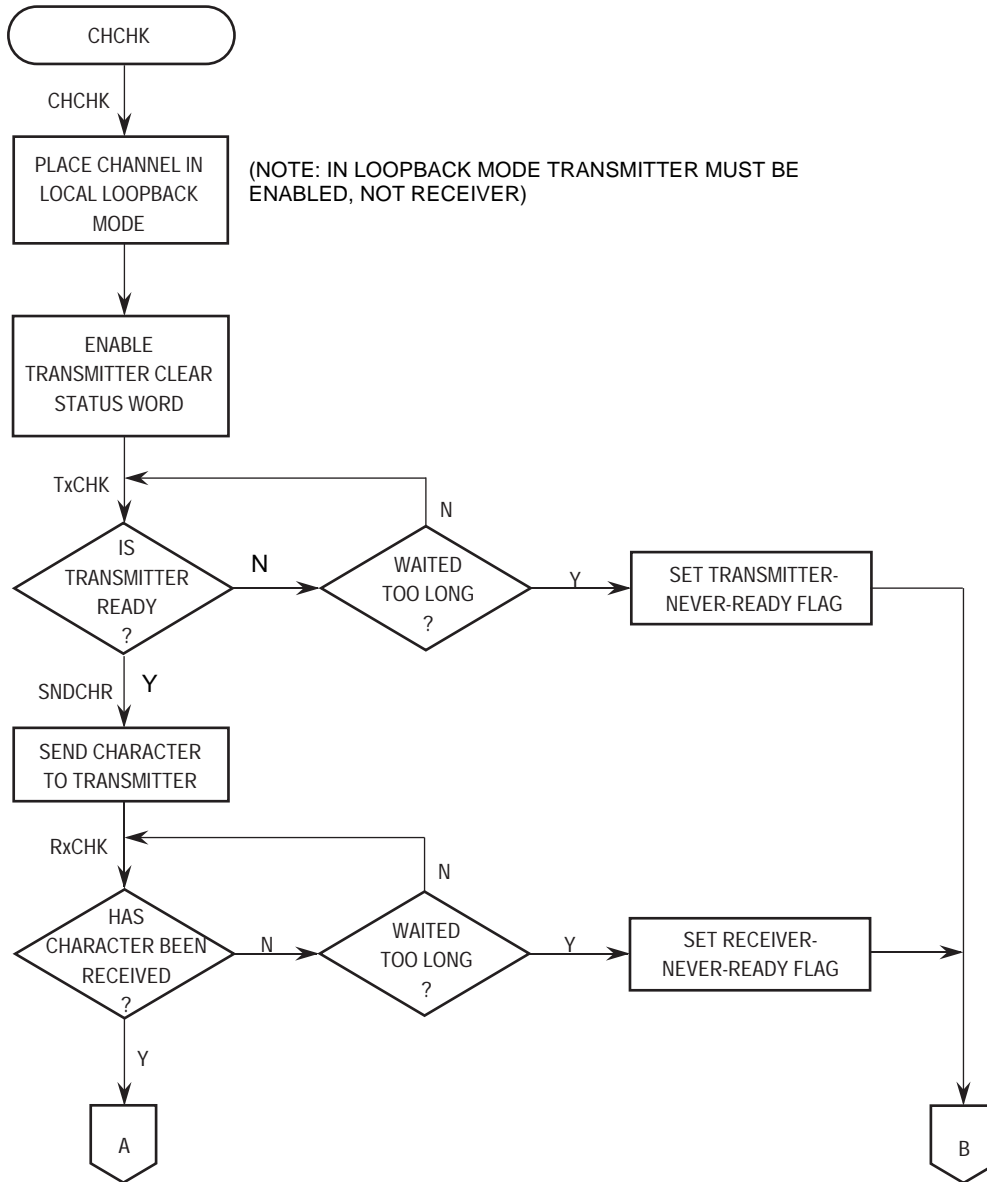
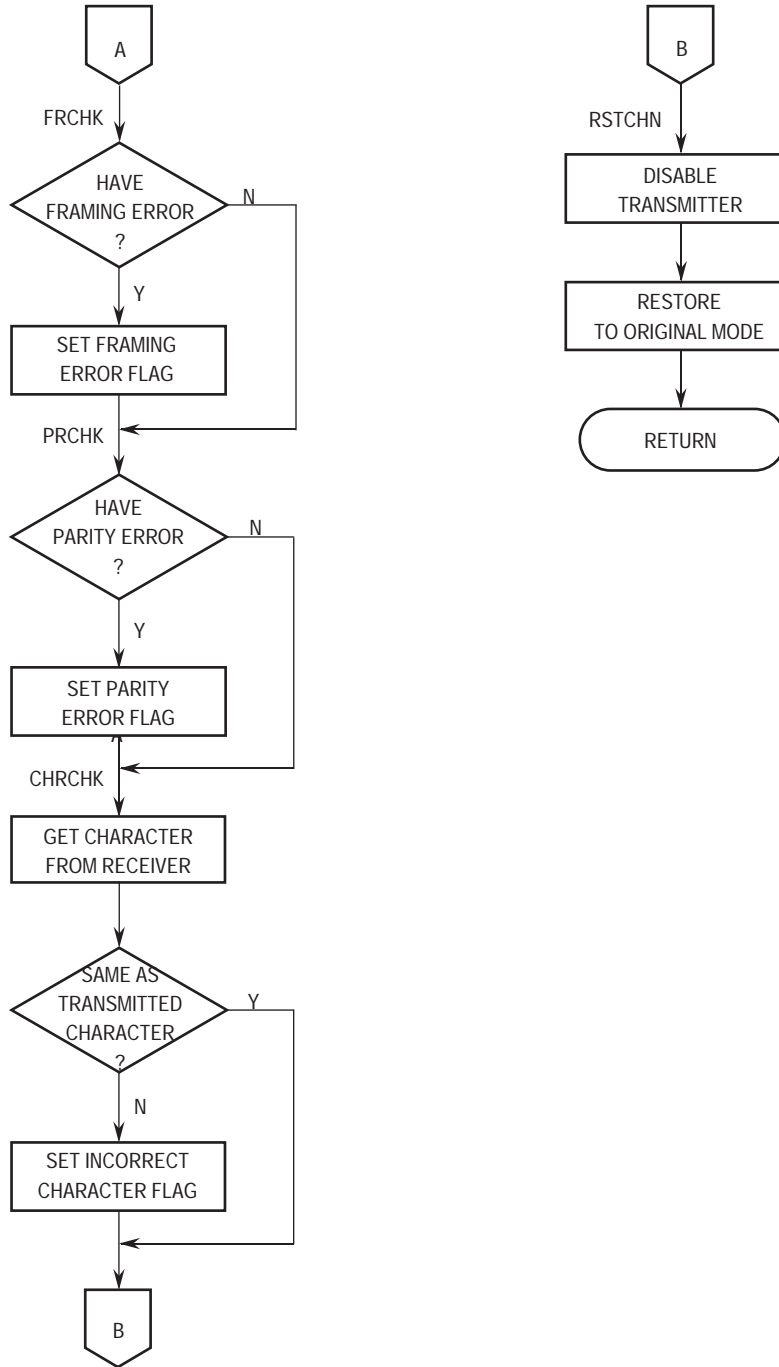
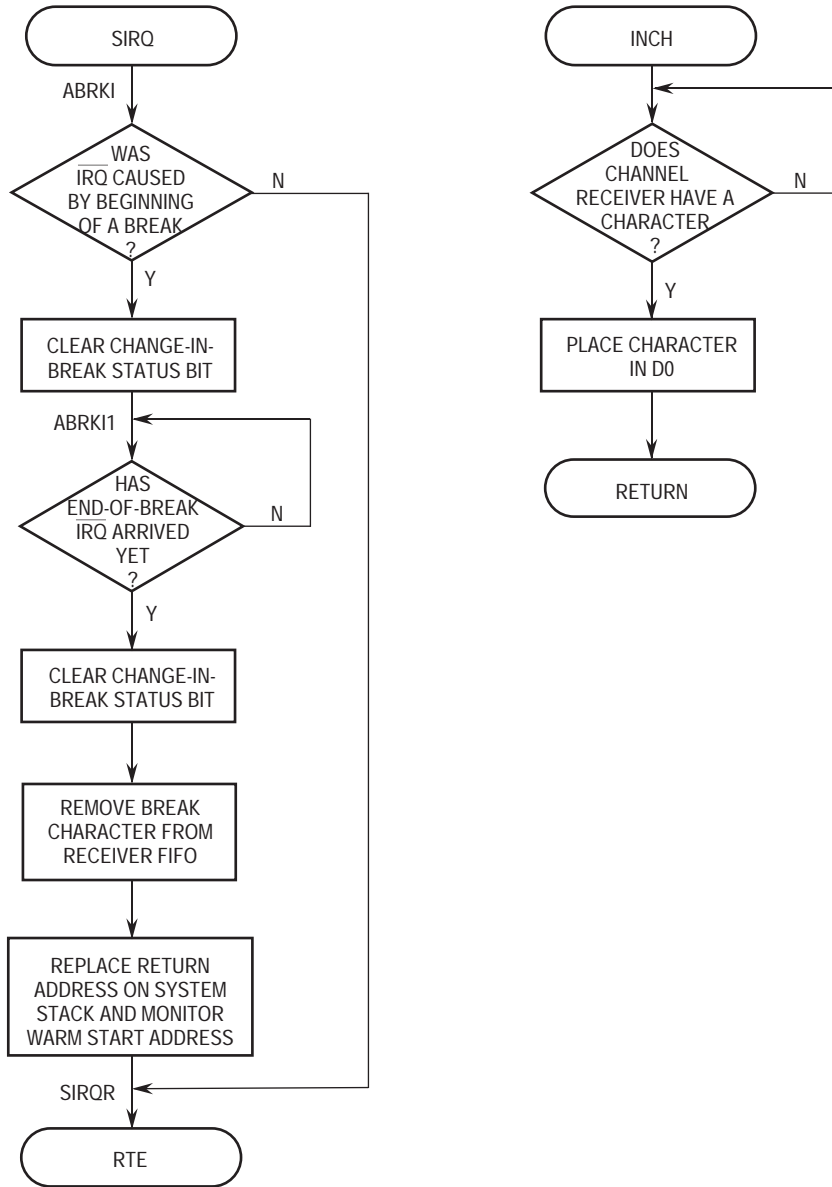

Figure 11-9. UART Software Flowchart (2 of 5)





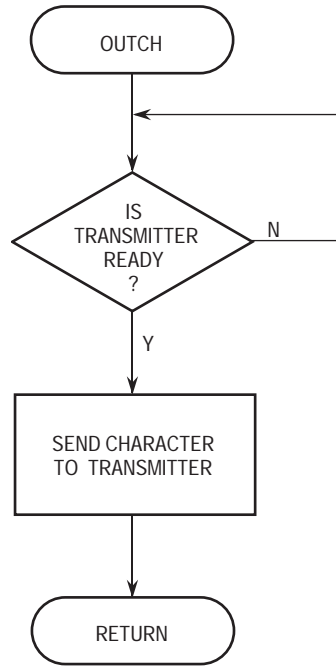

Figure 11-9. UART Software Flowchart (5 of 5)

SECTION 13 M-BUS MODULE

13.1 OVERVIEW

Motorola bus (M-Bus) is a two-wire, bidirectional serial bus that provides a simple, efficient method of data exchange between devices. It is compatible with the widely used I²C bus standard¹. This two-wire bus minimizes the interconnection between devices.

This bus is suitable for applications requiring occasional communications over a short distance between many devices. The flexible M-Bus allows additional devices to be connected to the bus for expansion and system development.

The interface operates up to 100 kbps with maximum bus loading and timing.

The M-Bus system is a true multimaster bus including collision detection and arbitration that prevents data corruption if two or more masters attempt to control the bus simultaneously. This feature allows for complex applications with multiprocessor control. It can also be used for rapid testing and alignment of end products via external connections to an assembly line computer.

13.2 INTERFACE FEATURES

The M-Bus module has the following key features:

- Compatibility with I²C Bus standard
- Multimaster operation
- Software-programmable for one of 64 different serial clock frequencies
- Software-selectable acknowledge bit
- Interrupt-driven byte-by-byte data transfer
- Arbitration-lost interrupt with automatic mode switching from master to slave
- Calling address identification interrupt
- Start and stop signal generation/detection
- Repeated START signal generation
- Acknowledge bit generation/detection
- Bus-busy detection

¹. I²C-Bus is a proprietary Phillips interface bus.

A block diagram of the complete M-Bus Module is shown in Figure 13-1.

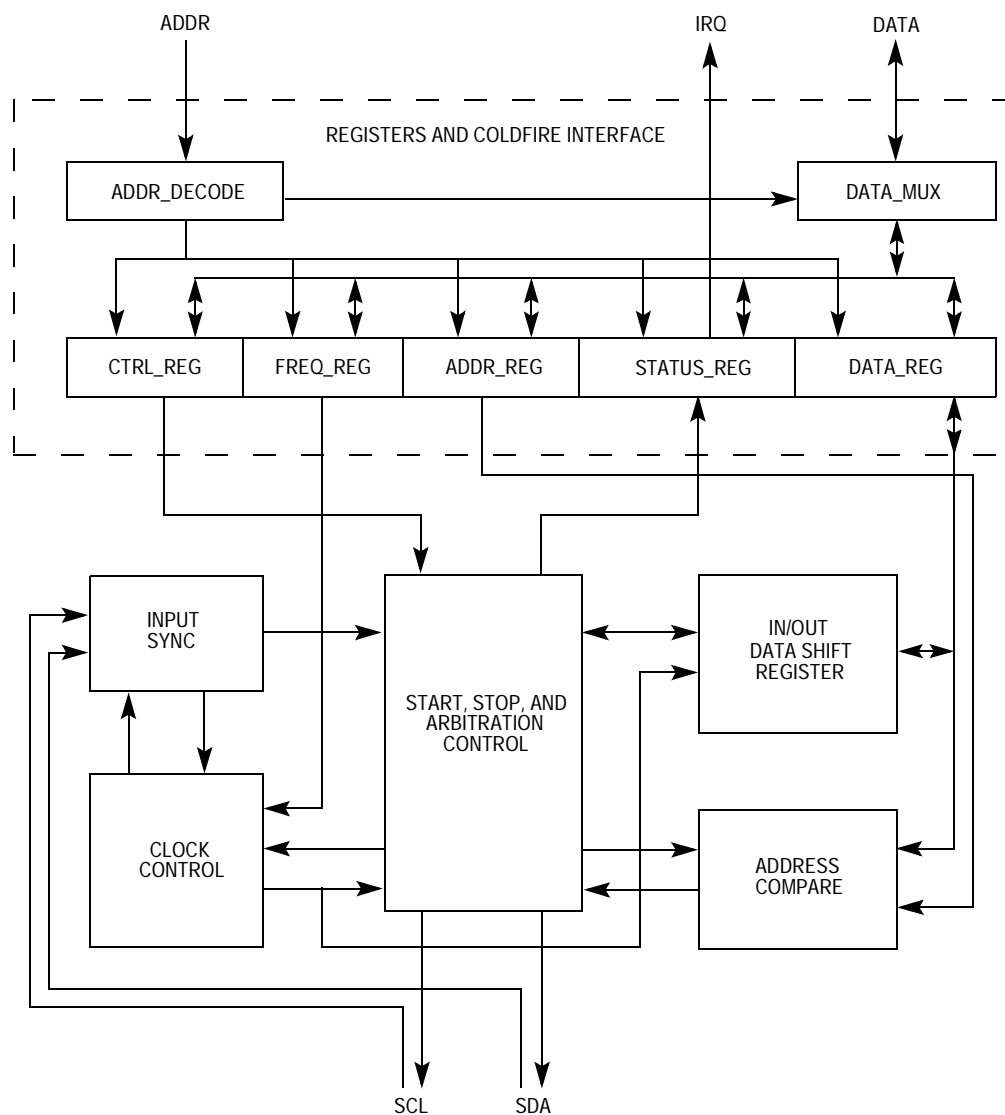

Figure 13-1. M-Bus Module Block Diagram

13.3 M-BUS SYSTEM CONFIGURATION

The M-Bus system uses a serial data line (SDA) and a serial clock line (SCL) for data transfer. All devices connected to these two signals must have open drain or open collector outputs. The logic AND function is exercised on both lines with pullup resistors.

The default state of the M-Bus is as a slave receiver out of reset. Thus, when not programmed to be a master or responding to a slave transmit address, the M-Bus should always return to the default state of slave receiver.

NOTE

For further information on M-Bus system configuration, protocol, and restrictions please refer to the Philip's I²C Standard

13.4 M-BUS PROTOCOL

Normally, a standard communication is composed of four parts: (1) START signal, (2) slave address transmission, (3) data transfer, and (4) STOP signal. They are described briefly in the following sections and illustrated in Figure 13-2.

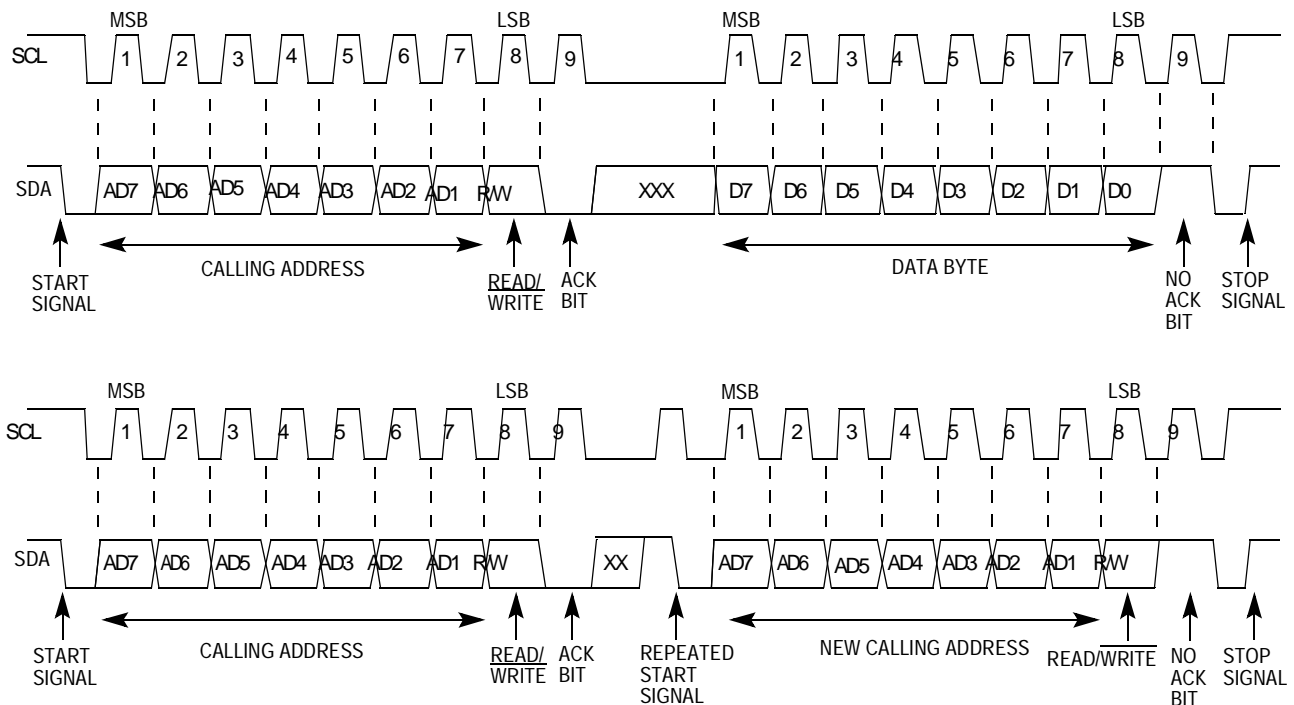

Figure 13-2. M-Bus Standard Communication Protocol

13.4.1 START Signal

When the bus is free, i.e., no master device is engaging the bus (both SCL and SDA lines are at logic high), a master can initiate communication by sending a START signal. As shown in Figure 13-2, a START signal is defined as a high-to-low transition of SDA while SCL is high. This signal denotes the beginning of a new data transfer (each data transfer can contain several bytes of data) and awakens all slaves.

13.4.2 Slave Address Transmission

The first byte of data transferred by the master immediately after the START signal is the slave address. This is a seven-bit calling address followed by a R/W bit. The R/W bit tells the slave data transfer direction. No two slaves in the system can have the same address.

In addition, if the MCF5206e is master, it must not transmit an address that is equal to its slave address. The MCF5206e cannot be master and slave at the same time.

Only the slave with a calling address that matches the one transmitted by the master will respond by returning an acknowledge bit by pulling the SDA low at the 9th clock (see Figure 13-2).

13.4.3 Data Transfer

Once successful slave addressing is achieved, the data transfer can proceed on a byte-by-byte basis in the direction specified by the R/W bit sent by the calling master.

Each data byte is 8 bits long. Data can be changed only while SCL is low and must be held stable while SCL is high, as shown in Figure 13-2. There is one clock pulse on SCL for each data bit with the MSB being transferred first. Each byte data must be followed by an acknowledge bit, which is signalled from the receiving device by pulling the SDA low at the ninth clock. One complete data byte transfer needs nine clock pulses.

If the slave receiver does not acknowledge the master, the SDA line must be left high by the slave. The master can then generate a stop signal to abort the data transfer or a start signal (repeated start) to commence a new calling.

If the master receiver does not acknowledge the slave transmitter after a byte transmission, it means "end of data" to the slave. The slave releases the SDA line for the master to generate STOP or START signal.

13.4.4 Repeated START Signal

As shown in Figure 13-2, a repeated START signal is a START signal generated without first generating a STOP signal to terminate the communication. The master uses this method to communicate with another slave or with the same slave in different mode (transmit/receive mode) without releasing the bus.

13.4.5 STOP Signal

The master can terminate the communication by generating a STOP signal to free the bus. However, the master can generate a repeated START by issuing a START signal followed by a calling command without generating a STOP signal first. This is called repeated START. A STOP signal is defined as a low-to-high transition of SDA while SCL at logical "1" (see Figure 13-2). Note that a master can generate a STOP even if the slave has done an acknowledgment at which point the slave must release the bus.

13.4.6 Arbitration Procedure

M-Bus is a true multimaster bus that allows more than one master to be connected on it. If two or more masters try to simultaneously control the bus, a clock synchronization procedure determines the bus clock, for which the low period is equal to the longest clock low period and the high is equal to the shortest one among the masters. A data arbitration procedure determines the relative priority of the contending masters. A bus master loses arbitration if it transmits logic "1" while another master transmits logic "0." The losing masters

immediately switch over to slave-receive mode and stop driving SDA output. In this case, the transition from master to slave mode does not generate a STOP condition. Meanwhile, hardware sets a status bit to indicate loss of arbitration.

13.4.7 Clock Synchronization

Because wire-AND logic is performed on SCL line, a high-to-low transition on SCL line affects all the devices connected on the bus. The devices start counting their low period when the master drives the SCL line low. Once a device clock has gone low, it holds the SCL line low until the clock high state is reached. However, the change of low to high in this device clock may not change the state of the SCL line if another device clock is still within its low period. Therefore, synchronized clock SCL is held low by the device with the longest low period. Devices with shorter low periods enter a high wait state during this time (see Figure 13-3). When all devices concerned have counted off their low period, the synchronized clock SCL line is released and pulled high. There is then no difference between the device clocks and the state of the SCL line and all the devices start counting their high periods. The first device to complete its high period pulls the SCL line low again.

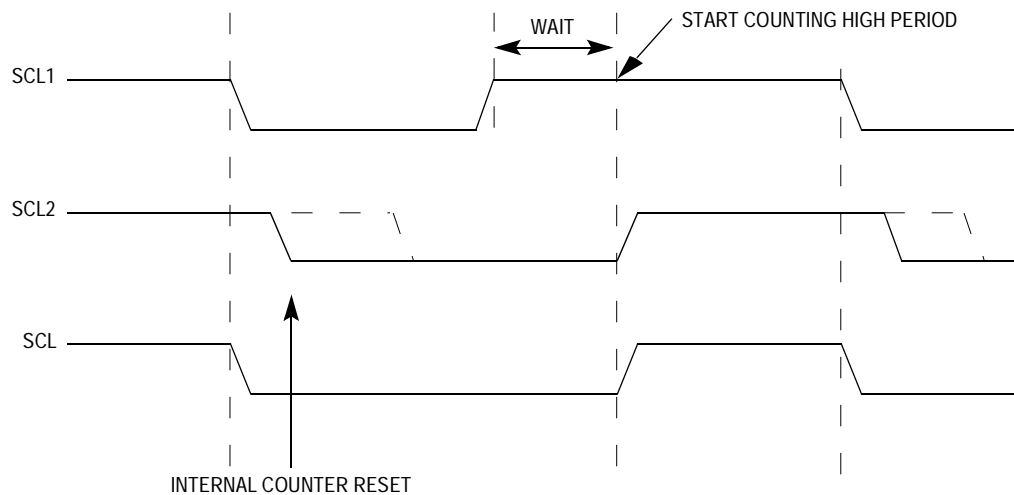

Figure 13-3. Synchronized Clock SCL

13.4.8 Handshaking

The clock synchronization mechanism can be used as a handshake in data transfer. Slave devices can hold the SCL low after completion of one byte transfer (9 bits). In such cases, it halts the bus clock and forces the master clock into wait states until the slave releases the SCL line.

13.4.9 Clock Stretching

Slaves can use the clock synchronization mechanism to slow down the transfer bit rate. After the master has driven SCL low the slave can drive SCL low for the required period and

then release it. If the slave SCL low period is greater than the master SCL low period, the resulting SCL bus signal low period is stretched.

13.5 PROGRAMMING MODEL

Five registers are used in the M-Bus interface and the internal configuration of these registers is discussed in the following paragraphs. The programmer's model of the M-Bus interface is shown below in Table 13-1.

Table 13-1. M-Bus Interface Programmer's Model

ADDRESS	M-BUS MODULE REGISTERS
MBAR+\$1E0	M-Bus Address register (MADR)
MBAR+\$1E4	M-Bus Frequency Divider Register (MFDR)
MBAR+\$1E8	M-Bus Control Register (MBCR)
MBAR+\$1EC	M-Bus Status Register (MBSR)
MBAR+\$1F0	M-Bus Data I/O Register (MBDR)

A block diagram of the M-Bus system is shown in Figure 13-1.

13.5.1 M-Bus Address Register (MADR)

This register contains the address the M-Bus responds to when addressed as a slave; note that it is not the address sent on the bus during the address transfer.

M-Bus Address Register (MADR)				Address MBAR+\$1E0			
7	6	5	4	3	2	1	0
ADR7	ADR6	ADR5	ADR4	ADR3	ADR2	ADR1	-
RESET	0	0	0	0	0	0	0
Read/Write				Supervisor or User Mode			

ADR7–ADR1 — Slave Address

Bit 1 to bit 7 contain the specific slave address to be used by the M-Bus module.

NOTE

The default mode of M-Bus is slave mode for an address match on the bus.

13.5.2 M-Bus Frequency Divider Register (MFDR)

M-Bus Frequency Divider Register (MFDR)				Address MBAR+\$1E4			
7	6	5	4	3	2	1	0
-	-	MBC5	MBC4	MBC3	MBC2	MBC1	MBC0
RESET	0	0	0	0	0	0	0
Read/Write				Supervisor or User Mode			

MBC5–MBC0 — M-Bus Clock Rate 5–0

This field is used to prescale the clock for bit rate selection. Due to the potential slow rise and fall times of the SCL and SDA signals, the bus signals are sampled at the prescaler

frequency. The serial bit clock frequency is equal to the CPU clock divided as shown in Table 13-2, which also shows the serial bit clock frequency for a 33 MHz internal operating frequency². Note that the MFDR frequency value can be changed at any point in a program.

Table 13-2. MBUS Prescaler Values

MBC5-0 (HEX)	DIVIDER (DEC)	MBC5-0 (HEX)	DIVIDER (DEC)
00	28	20	20
01	30	21	22
02	34	22	24
03	40	23	26
04	44	24	28
05	48	25	32
06	56	26	36
07	68	27	40
08	80	28	48
09	88	29	56
0A	104	2A	64
0B	128	2B	72
0C	144	2C	80
0D	160	2D	96
0E	192	2E	112
0F	240	2F	128
10	288	30	160
11	320	31	192
12	384	32	224
13	480	33	256
14	576	34	320
15	640	35	384
16	768	36	448
17	960	37	512
18	1152	38	640
19	1280	39	768
1A	1536	3A	896
1B	1920	3B	1024
1C	2304	3C	1280
1D	2560	3D	1536
1E	3072	3E	1792
1F	3840	3F	2048

² In previous implementations of the M-Bus (e.g., MC68307), the MBC[5] bit was not implemented. Clearing this bit in software maintains complete compatibility with such products.

13.5.3 M-Bus Control Register (MBCR)

M-Bus Control Register (MBCR)							Address MBAR+\$1E8	
	7	6	5	4	3	2	1	0
	MEN	MIEN	MSTA	MTX	TXAK	RSTA	-	
RESET	0	0	0	0	0	0	0	0
	Read/Write					Supervisor or User Mode		

MEN — M-Bus Enable

This bit controls the software reset of the entire M-Bus module.

- 1 = The M-Bus module is enabled. This bit must be set before any other MBCR bits have any effect.
- 0 = The module is reset and disabled. This is the power-on reset situation. When low, the interface is held in reset but registers can still be accessed.

If the M-Bus module is enabled in the middle of a byte transfer, the interface behaves as follows: the slave mode ignores the current transfer on the bus and starts operating whenever a subsequent start condition is detected. Master mode will not be aware that the bus is busy; therefore, if a start cycle is initiated, the current bus cycle can become corrupt. This would ultimately result in either the current bus master or the M-Bus module losing arbitration, after which bus operation would return to normal.

MIEN — M-Bus Interrupt Enable

- 1 = Interrupts from the M-Bus module are enabled. An M-Bus interrupt occurs provided the MIF bit in the status register is also set.
- 0 = Interrupts from the M-Bus module are disabled. This does not clear any currently pending interrupt condition.

MSTA — Master/Slave Mode Select Bit

At reset, this bit is cleared. When this bit is changed from 0 to 1, a START signal is generated on the bus, and the master mode is selected. When this bit is changed from 1 to 0, a STOP signal is generated and the operation mode changes from master to slave.

MSTA is cleared without generating a STOP signal when the master loses arbitration.

- 1 = Master Mode
- 0 = Slave Mode

MTX — Transmit/Receive mode select bit

This bit selects the direction of master and slave transfers. When addressed as a slave this bit should be set by software according to the SRW bit in the status register. In master mode, this bit should be set according to the type of transfer required. Therefore, for address cycles, this bit is always high.

- 1 = Transmit
- 0 = Receive

TXAK — Transmit Acknowledge Enable

This bit specifies the value driven onto SDA during acknowledge cycles for both master and slave receivers. *Note that writing this bit only applies when the M-Bus is a receiver, not a transmitter.*

1 = No acknowledge signal response is sent (i.e., acknowledge bit = 1)

0 = An acknowledge signal is sent out to the bus at the 9th clock bit after receiving one byte data

RSTA — Repeat Start

Writing a 1 to this bit generates a repeated START condition on the bus, provided it is the current bus master. This bit is always read as a low. Attempting a repeated start when the bus is owned by another master results in loss of arbitration. Note that this bit is not readable.

1 = Generate repeat start cycle

13.5.4 M-Bus Status Register (MBSR)

This status register is read-only with the exception of bit 1 (MIF) and bit 4 (MAL), which can be cleared by software. All bits are cleared on reset except bit 7 (MCF) and bit 0 (RXAK), which are set (=1) at reset.

M-Bus Status Register (MBSR)					Address MBAR+\$1EC			
	7	6	5	4	3	2	1	0
	MCF	MAAS	MBB	MAL	-	SRW	MIF	RXAK
RESET	1	0	0	0	0	0	0	1
	Read/Write					Supervisor or User Mode		

MCF — Data Transferring Bit

While one byte of data is being transferred, this bit is cleared. It is set by the falling edge of the 9th clock of a byte transfer.

1 = Transfer complete

0 = Transfer in progress

MAAS — Addressed as a Slave Bit

When its own specific address (M-Bus Address Register) is matched with the calling address, this bit is set. The CPU is interrupted provided the MIEN is set. Next, the CPU must check the SRW bit and set its TX/RX mode accordingly.

Writing to the M-Bus Control Register clears this bit.

1 = Addressed as a slave

0 = Not addressed

MBB — Bus Busy Bit

This bit indicates the status of the bus. When a START signal is detected, the MBB is set. If a STOP signal is detected, it is cleared.

- 1 = Bus is busy
- 0 = Bus is idle

MAL — Arbitration Lost

Hardware sets the arbitration lost bit (MAL) when the arbitration procedure is lost. Arbitration is lost in the following circumstances:

1. SDA sampled as low when the master drives a high during an address or data-transmit cycle.
2. SDA sampled as a low when the master drives a high during the acknowledge bit of a data-receive cycle.
3. A start cycle is attempted when the bus is busy.
4. A repeated start cycle is requested in slave mode.
5. A stop condition is detected when the master did not request it.

This bit must be cleared by software by writing a low to it.

SRW — Slave Read/Write

When MAAS is set, this bit indicates the value of the R/W command bit of the calling address sent from the master. This bit is valid only when 1) a complete transfer has occurred and no other transfers have been initiated and 2) M-Bus is a slave and has an address match. Checking this bit, the CPU can select slave transmit/receive mode according to the command of the master.

- 1 = Slave transmit, master reading from slave
- 0 = Slave receive, master writing to slave

MIF — M-Bus Interrupt

The MIF bit is set when an interrupt is pending, which causes a processor interrupt request (provided MIEN is set). MIF is set when one of the following events occurs:

1. Complete one byte transfer (set at the falling edge of the 9th clock)
2. Receive a calling address that matches its own specific address in slave-receive mode
3. Arbitration lost

This bit must be cleared by software by writing a low to it in the interrupt routine.

RXAK — Received Acknowledge

The value of SDA during the acknowledge bit of a bus cycle. If the received acknowledge bit (RXAK) is low, it indicates an acknowledge signal has been received after the completion of

8 bits data transmission on the bus. If RXAK is high, it means no acknowledge signal has been detected at the 9th clock.

- 1 = No acknowledge received
- 0 = Acknowledge received

13.5.5 M-Bus Data I/O Register (MBDR)

M-Bus Data I/O Register (MBDR)					Address MBAR+\$1F0			
	7	6	5	4	3	2	1	0
	D7	D6	D5	D4	D3	D2	D1	D0
RESET	0	0	0	0	0	0	0	0
	Read/Write					Supervisor or User Mode		

When an address and R/W bit is written to the MBDR and the M-Bus is the master, a transmission starts. When data is written to the MBDR, a data transfer is initiated. The most significant bit is sent first in both cases. In the master receive mode, reading the MBDR register allows the read to occur but also initiates next byte data receiving. In slave mode, the same function is available after it is addressed.

13.6 M-BUS PROGRAMMING EXAMPLES

13.6.1 Initialization Sequence

Reset will put the M-Bus Control Register to its default status. Before the interface can transfer serial data, you must perform an initialization procedure as follows:

1. Update the Frequency Divider Register (MFDR) and select the required division ratio to obtain SCL frequency from system clock.
2. Update the M-Bus Address Register (MADR) to define its slave address.
3. Set the MEN bit of the M-Bus Control Register (MBCR) to enable the M-Bus interface system.
4. Modify the bits of the M-Bus Control Register (MBCR) to select master/slave mode, transmit/receive mode, and interrupt enable or not.

13.6.2 Generation of START

After completion of the initialization procedure, you can transmit serial data by selecting the "master transmitter" mode. If the device is connected to a multi-master bus system, you must test the state of the M-Bus Busy Bit (MBB) to check whether the serial bus is free.

If the bus is free (MBB=0), the start condition and the first byte (the slave address) can be sent. The data written to the data register comprises the slave-calling address and the LSB set to indicate the direction of transfer required from the slave.

The bus free time (i.e., the time between a STOP condition and the following START condition) is built into the hardware that generates the START cycle. Depending on the relative frequencies of the system clock and the SCL period, you may have to wait until the

M-Bus is busy after writing the calling address to the MBDR before proceeding with the following instructions.

An example of a program that generates the START signal and transmits the first byte of data (slave address) is shown below:

```
CHFLAGMOVE.BMBSR,-(A7); CHECK THE MBB BIT OF THE
BTST.B#5,(A7)+
BNE.SCHFLAG; STATUS REGISTER. IF IT IS
; SET, WAIT UNTIL IT IS CLEAR
TXSTARTMOVE.BMBCR,-(A7); SET TRANSMIT MODE
BSET.B#4,(A7)

MOVE.B(A7)+,MBCR
MOVE.BMBCR,-(A7);SET MASTER MODE
BSET.B#5,(A7); i.e. GENERATE START CONDITION
MOVE.B(A7)+,MBCR;
MOVE.BCALLING,-(A7); TRANSMIT THE CALLING
MOVE.B(A7)+,MBDR; ADDRESS, D0=R/W
MBFREEMOVE.BMBSR,-(A7); CHECK THE MBB BIT OF THE
BTST.B#5,(A7)+; STATUS REGISTER. IF IT IS
BEQ.SMBFREE; CLEAR, WAIT UNTIL IT IS SET
```

13.6.3 Post-Transfer Software Response

Transmission or reception of a byte sets the data transferring bit (MCF) to 1, which indicates one byte communication is finished. The M-Bus interrupt bit (MIF) is also set; an interrupt will be generated if the interrupt function is enabled during initialization by setting the MIEN bit. Software must clear the MIF bit in the interrupt routine first. The MCF bit is cleared by reading from the M-Bus Data I/O Register (MDR) in receive mode or writing to MDR in transmit mode.

Software can service the M-bus I/O in the main program by monitoring the MIF bit if the interrupt function is disabled. Polling should monitor the MIF bit rather than the MCF bit because that operation is different when arbitration is lost.

When an interrupt occurs at the end of the address cycle, the master is always in transmit mode, i.e. the address is transmitted. If master receive mode is required, indicated by R/W bit in MBDR, then the MTX bit should be toggled at this stage.

During slave-mode address cycles (MAAS=1), the SRW bit in the status register is read to determine the direction of the subsequent transfer and the MTX bit is programmed accordingly. For slave-mode data cycles (MAAS=0), the SRW bit is not valid. The MTX bit in the control register should be read to determine the direction of the current transfer.

The following is an example of a software response by a "master transmitter" in the interrupt routine (see Figure 13-4).

```

ISRLEA.LMBSR,-(A7); LOAD EFFECTIVE ADDR.
BCLR.B#1,(A7)+; CLEAR THE MIF FLAG
MOVE.BMBCR,-(A7); PUSH ADDRESS ON STACK,
BTST.B#5,(A7)+; CHECK THE MSTA FLAG
BEQ.SSLAVE; BRANCH IF SLAVE MODE
MOVE.BMBCR,-(A7); PUSH ADDRESS ON STACK,
BTST.B#4,(A7)+; CHECK THE MODE FLAG
BEQ.SRECEIVE; BRANCH IF IN RECEIVE MODE
MOVE.BMBSR,-(A7); PUSH ADDRESS ON STACK,
BTST.B#0,(A7)+; CHECK ACK FROM RECEIVER
BNE.B END; IF NO ACK, END OF TRANSMISSION
TRANSMITMOVE.BDATABUF,-(A7); STACK DATA BYTE
MOVE.B(A7)+,MBDR; TRANSMIT NEXT BYTE OF DATA

```

13.6.4 Generation of STOP

A data transfer ends with a STOP signal generated by the "master" device. A master transmitter can generate a STOP signal after all the data has been transmitted. The following is an example showing how a master transmitter generates a stop condition.

```

MASTXMOVE.BMBSR,-(A7); IF NO ACK, BRANCH TO END
BTST.B#0,(A7)+
BNE.B END
MOVE.BTXCNT,D0; GET VALUE FROM THE
; TRANSMITTING COUNTER
BEQ.SEND; IF NO MORE DATA, BRANCH TO
; END
MOVE.BDATABUF,-(A7); TRANSMIT NEXT BYTE OF DATA
MOVE.B(A7)+,MBDR
MOVE.BTXCNT,D0; DECREASE THE TXCNT
SUBQ.L#1,D0
MOVE.BD0,TXCNT
BRA.SEMASTX; EXIT
ENDLEA.LMBCR,-(A7); GENERATE A STOP CONDITION
BCLR.B#5,(A7)+
EMASTXRTE; RETURN FROM INTERRUPT

```

If a master receiver wants to terminate a data transfer, it must inform the slave transmitter by not acknowledging the last byte of data, which can be done by setting the transmit acknowledge bit (TXAK) before reading the 2nd last byte of data. Before reading the last byte of data, a STOP signal must be generated first. The following is an example showing how a master receiver generates a STOP signal.

```

MASRMOVE.BRXCNT,D0;DECREASE RXCNT
SUBQ.L#1,D0
MOVE.BD0,RXCNT
BEQ.SENMASR; LAST BYTE TO BE READ
MOVE.BRXCNT,D1; CHECK SECOND LAST BYTE
EXTB>LD1
SUBI.L#1,D1; TO BE READ
BNE.SNXMAR; NOT LAST ONE OR SECOND LAST
LAMARBSET.B#3,MBCR; SECOND LAST, DISABLE ACK

```

```

; TRANSMITTING
BRANXMAR
ENMASRBCLR.B#5,MBCR; LAST ONE, GENERATE 'STOP'
; SIGNAL
NXMARMOVE.BMBDR,RXBUF; READ DATA AND STORE
RTE

```

13.6.5 Generation of Repeated START

At the end of data transfer, if the master still wants to communicate on the bus, it can generate another START signal followed by another slave address without first generating a STOP signal. A program example is as shown.

```

RESTARTMOVE.BMBCR,-(A7); ANOTHER START (RESTART)
BSET.B#2, (A7)
MOVE.B(A7)+, MBCR
MOVE.BCALLING,-(A7); TRANSMIT THE CALLING
MOVE.BCALLING,-(A7); ADDRESS, D0=R/W-
MOVE.B(A7)+, MBDR

```

13.6.6 Slave Mode

In the slave interrupt service routine, the module addressed as slave bit (MAAS) should be tested to check if a calling of its own address has just been received. If MAAS is set, software should set the transmit/receive mode select bit (MTX bit of MBCR) according to the R/W command bit (SRW). Writing to the MBCR clears the MAAS automatically. The only time MAAS is read as set is from the interrupt at the end of the address cycle where an address match occurred; interrupts resulting from subsequent data transfers have MAAS cleared. A data transfer can now be initiated by writing information to MBDR, for slave transmits, or dummy reading from MBDR, in slave-receive mode. The slave drives SCL low in between byte transfers. SCL is released when the MBDR is accessed in the required mode.

In the slave transmitter routine, the received acknowledge bit (RXAK) must be tested before transmitting the next byte of data. Setting RXAK means an "end-of-data" signal from the master receiver, after which it must be switched from transmitter mode to receiver mode by software. A dummy read then releases the SCL line so that the master can generate a STOP signal.

13.6.7 Arbitration Lost

If several masters try to simultaneously engage the bus, only one master wins and the others lose arbitration. The devices that lost arbitration are immediately switched to slave receive mode by the hardware. Their data output to the SDA line is stopped, but SCL is still generated until the end of the byte during which arbitration was lost. An interrupt occurs at the falling edge of the ninth clock of this transfer with MAL=1 and MSTA=0. If one master tries to transmit or do a START while the bus is being engaged by another master, the hardware will: (1) inhibit the transmission, (2) switch the MSTA bit from 1 to 0 without generating STOP condition, (3) generate an interrupt to CPU and, (4) set the MAL to indicate

the failed attempt to engage the bus. When considering these cases, the slave service routine should test the MAL first and the software should clear the MAL bit if it is set.

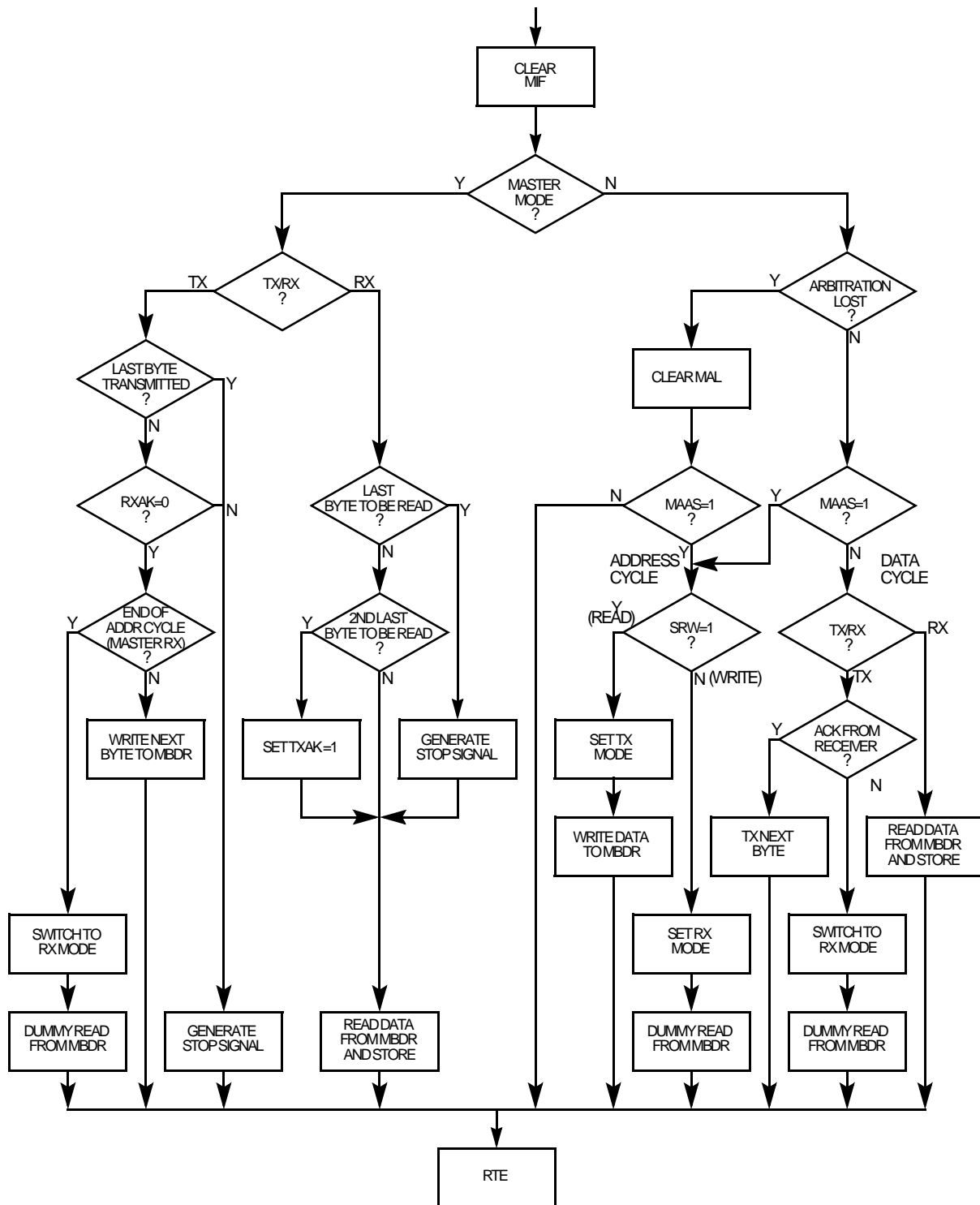

Figure 13-4. Flow-Chart of Typical M-Bus Interrupt Routine

Freescale Semiconductor, Inc.

SECTION 14 TIMER MODULE

14.1 OVERVIEW OF THE TIMER MODULE

The MCF5206e contains two general-purpose 16-bit timers. This section of the manual documents how the 16-bit timers operate.

The output of an 8-bit prescaler clocks each 16-bit timer. The prescaler input can be the system clock, the system clock divided by 16, or the timer input (TIN) pin. Figure 14-1 is a block diagram of the timer module.

Both timer pins are multiplexed with the DMA request function. Their function is defined by programming bits 8 and 9 of the PAR (Pin Assignment Register).

14.2 OVERVIEW OF KEY FEATURES

The general-purpose 16-bit timer unit has the following features:

- Maximum period of 5 seconds at 54 MHz & 6.7 seconds at 40 MHz.
- 18.5 ns resolution at 54 MHz & 25 ns at 40 MHz
- Programmable sources for the clock input, including external clock
- Input-capture capability with programmable trigger edge on input pin
- Output-compare with programmable mode for the output pin
- Free run and restart modes
- Maskable interrupts on input capture or reference-compare

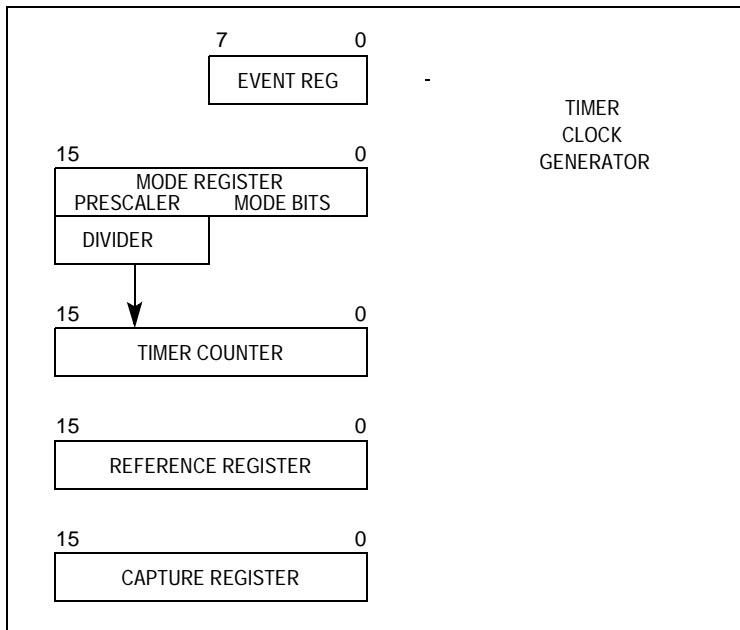

Figure 14-1. Timer Block Diagram Module Operation

14.3 GENERAL-PURPOSE TIMER UNITS

The general-purpose timer units provide the following features:

- You can program timers to count and compare to a reference value stored in a register or capture the timer value at an edge detected on the TIN pin
- An 8-bit prescaler output clocks the timers
- You can program the prescaler clock input
- Programmed events generate interrupts
- You can configure the TOUT pin to toggle or pulse on an event

The maximum resolution of each timer is one system clock cycle (18.5 ns at 54 MHz). To obtain the maximum period, divide the system clock by 16, set the prescaler value to divide by 256, and load the reference value with ones. This maximum period is 268,435,456 cycles (4.97 seconds at 54 MHz).

14.3.1 Selecting the Prescaler

You can select the prescaler clock from the main clock (divided by 1 or by 16) or from the corresponding timer input TIN pin. TIN is synchronized to the internal clock. The synchronization delay is between two and three main clocks. TIN must meet the setup time spec shown in the AC Electrical Specs section.

The ICLK bits of the corresponding Timer Mode Register (TMR) select the clock input source. The prescaler is programmed to divide the clock input by values from 1 to 256. The prescaler output is used as an input to the 16-bit counter.

14.3.2 Capture Mode

The timer has a 16-bit Timer Capture Register (TCR) that latches the counter value when the corresponding input capture-edge detector senses a defined transition of TIN. The capture edge (CE) bits in the TMR select the type of transition triggering the capture. A capture event sets the Timer Event Register (TER) bit and issues a maskable interrupt.

14.3.3 Configuring the Timer for Reference Compare

You can configure the timer to count until it reaches a reference value at which time it either starts a new time count immediately or continues to run. The free run/restart (FRR) bit of the TMR selects either mode. When the timer reaches the reference value, the TER bit is set and issues an interrupt if the output reference interrupt (ORI) enable bit in TMR is set.

14.3.4 Configuring the Timer for Output Mode

The timer can send an output signal on the timer output (TOUT) pin when it reaches the reference value as selected by the output mode (OM) bit in the TMR. This signal can be an active-low pulse or a toggle of the current output under program control.

14.4 PROGRAMMING MODEL

14.4.1 Understanding the General-Purpose Timer Registers

You can modify the timer registers at any time. Table 14-1 illustrates the programming model.

Table 14-1. Programming Model for Timers

TIMER 1 ADDRESS	TIMER 2 ADDRESS	TIMER MODULE REGISTERS	
MBAR+\$100	MBAR+\$120	Timer Mode Register (TMR)	
MBAR+\$104	MBAR+\$124	Timer Reference Register (TRR)	
MBAR+\$108	MBAR+\$128	Timer Capture Register (TCR)	
MBAR+\$10C	MBAR+\$12C	Timer Counter (TCN)	
MBAR+\$111	MBAR+\$131	Reserved	Timer Event Register (TER)

14.4.1.1 TIMER MODE REGISTER (TMR). TMR is a 16-bit memory-mapped register. This register programs the various timer modes and is cleared by reset.

Timer Mode Register (TMR)											Address MBAR+\$100, MBAR+\$120					
	15	14	13	12	11	10	9	8	7	6	5	4	3	2	1	0
	PRESCALER VALUE (PS7 - PS0)								CE1-CE0		OM	ORI	FRR	CLK1-CLK0		RST
RESET	0	0	0	0	0	0	0	0	0	0	0	0	0	0	0	0
	Read/Write										Supervisor or User Mode					

PS7–PS0 — Prescaler Value

The prescaler is programmed to divide the clock input by values from 1 to 256. The value 00000000 divides the clock by 1; the value 11111111 divides the clock by 256.

$$\text{Prescalar value} = \text{[PS7 - PS0]} + 1$$

CE1–CE0 — Capture Edge and Enable Interrupt

- 11 = Capture on any edge and enable interrupt on capture event
- 10 = Capture on falling edge only and enable interrupt on capture event
- 01 = Capture on rising edge only and enable interrupt on capture event
- 00 = Disable interrupt on capture event

OM — Output Mode

- 1 = Toggle output
- 0 = Active-low pulse for one system clock cycle (18.5 ns at 54 MHz)

ORI — Output Reference Interrupt Enable

- 1 = Enable interrupt upon reaching the reference value
- 0 = Disable interrupt for reference reached (does not affect interrupt on capture function)

NOTE

If ORI is set when the REF event is asserted in the Timer Event Register (TER), an immediate interrupt occurs. If ORI is cleared while an interrupt is asserted, the interrupt negates.

FRR — Free Run/Restart

- 1 = Restart: Timer count is reset immediately after reaching the reference value
- 0 = Free run: Timer count continues to increment after reaching the reference value

CLK1–CLK0 — Input Clock Source for the Timer

- 11 = TIN pin (falling edge)
- 10 = Master system clock divided by 16. Note that this clock source is not synchronized to the timer; thus successive time-outs may vary slightly in length
- 01 = Master system clock
- 00 = Stops counter. After the counter is stopped, the value in the Timer Counter (TCN) register remains constant.

RST — Reset Timer

This bit performs a software timer reset identical to that of an external reset. All timer registers takes on their corresponding reset values. While this bit is zero, the other register values can still be written, if necessary. A transition of this bit from one to zero is what resets the register values. The counter/timer/prescaler is not clocked unless the timer is enabled.

1 = Enable timer

0 = Reset timer (software reset)

14.4.1.2 TIMER REFERENCE REGISTER (TRR). The TRR is a 16-bit register containing the reference value that is compared with the free-running timer counter (TCN) as part of the output-compare function. TRR is a memory-mapped read/write register.

TRR is set at reset. The reference value is not matched until TCN equals TRR, and the prescaler indicates that the TCN should be incremented again. Thus, the reference register is matched after (TRR+1) time intervals.

Timer Reference Register (TRR)																Address MBAR+\$104,MBAR+\$124	
	15	14	13	12	11	10	9	8	7	6	5	4	3	2	1	0	
	16-BIT REFERENCE COMPARE VALUE REF15 - REF0																
RESET	1	1	1	1	1	1	1	1	1	1	1	1	1	1	1	1	1
	Read/Write												Supervisor or User Mode				

14.4.1.3 TIMER CAPTURE REGISTER (TCR). The TCR is a 16-bit register that latches the value of the timer counter (TCN) during a capture operation when an edge occurs on the TIN pin, as programmed in the TMR. TCR appears as a memory-mapped read-only register and is cleared at reset.

Timer Capture Register (TCR)																Address MBAR+\$108,MBAR+\$128	
	15	14	13	12	11	10	9	8	7	6	5	4	3	2	1	0	
	16-BIT CAPTURE COUNTER VALUE CAP15 - CAP0																
RESET	0	0	0	0	0	0	0	0	0	0	0	0	0	0	0	0	0
	Read Only												Supervisor or User Mode				

14.4.1.4 TIMER COUNTER (TCN). TCN is a memory-mapped 16-bit up counter that you can read at any time. A read cycle to TCN yields the current timer value and does not affect the counting operation.

A write of any value to TCN causes it to reset to all zeros.

Timer Counter Register (TCN)																Address MBAR+\$10C, MBAR+\$12C	
	15	14	13	12	11	10	9	8	7	6	5	4	3	2	1	0	
	16-BIT TIMER COUNTER VALUE COUNT15 - COUNT0																
RESET	0	0	0	0	0	0	0	0	0	0	0	0	0	0	0	0	0
	Read/Write												Supervisor or User Mode				

14.4.1.5 TIMER EVENT REGISTER (TER). The TER is an 8-bit register that reports events the timer recognizes. When the timer recognizes an event, it sets the appropriate bit in the TER, regardless of the corresponding interrupt-enable bits (ORI and CE) in the TMR.

TER appears as a memory-mapped register and can be read at any time.

You should write a one to a bit to clear it (writing a zero does not affect bit value); more than one bit can be cleared at a time. The REF and CAP bits must be cleared before the timer will negate the IRQ to the interrupt controller. Reset clears this register.

Timer Event Register (TER)								Address MBAR+\$111,MBAR+\$131		
	7	6	5	4	3	2	1	0		
	RESERVED READ AS 0						REF	CAP		
RESET	0	0	0	0	0	0	0	0		
	Read/Write					Supervisor or User Mode				

Bits 7–2 — Reserved for future use.

These bits are currently 0 when read.

CAP — Capture Event

If a one is read from this bit, the counter value has been latched into the TCR. The CE bit in the TMR enables the interrupt request caused by this event. You should write a one to this bit to clear the event condition.

REF — Output Reference Event

If a one is read from this bit, the counter has reached the TRR value. The ORI bit in the TMR enables the interrupt request caused by this event. You should write a one to this bit to clear the event condition.

Example code: Timer Initialization

There are two timers on the MCF5206e. With a 54MHz clock, the maximum period is 5 seconds and a resolution of 18.5 ns. They can be free running or count to a value and reset. The following examples set up the timers:

Timer 1 will count to \$AF AF, toggle its output, and reset back to \$0000. This will continue infinitely until the timer is disabled or a reset occurs. No interrupts are set. Prescale is set at 256 and the system clock is divided by 16, therefore resolution is $(16 \cdot (256)) / 25\text{MHz} = 163.84\mu\text{s}$. Timeout period is $(16 \cdot 256 \cdot 44976) / 25\text{mhz} = 7.369\text{s}$. ($\$0 - \$AF AF = 44976$ decimal)

Timer 2 will be free-running and send out a logic pulse every time it compares the count value in the TRR register. value, which for now, is randomly chosen as \$1234. Prescale is set at 127 with the sys_clock initially divided by 16 (by setting bits 2&1 of the TMR register to 10 therefore, resolution is $(16 \cdot (127)) / 25\text{mhz} = 81.28\mu\text{s}$. Interrupts are NOT enabled.

NOTE

The timers were initialized in the SIM to have interrupt values. The examples below have the interrupts disabled. The initialization in the SIM configuration was for reference. The Timers CANNOT provide interrupt vectors, only autovectors.

Autovectors and ICRs have been set up as follows. The interrupt levels and priorities were chosen by random for demonstrative purposes. You should define the interrupt level and priorities for your specific application.

SIMR register

The SIMR is set up as follows:

- 1) Disable watchdog when FREEZE is asserted (bit 7)
- 2) Disable bus monitor when FREEZE is asserted (bit 6)
- 3) 5206 will negate the /BD signal

```
move.b  %#11000000,D0    ;set up the SIMR (pg 7-9)
move.b  D0,SIMR;
```

NOTE*

The timer & MBUS peripherals cannot provide interrupt vectors. Timer & MBUS peripherals are only autovectored. Interrupt values were chosen randomly for demonstrative purposes. You should change these for your own application needs.

```
move.b  %#10000100,D0 ;set up Timer 1 Interrupt
move.b  D0,ICR9      ;Level 2 interrupt, Priority 0,
                    ;Autovector=ON,
                    ;avect 24+1=25

move.b  %#10001001,D0 ;set up Timer 2 Interrupt
move.b  D0,ICR10     ;Level 2 interrupt, Priority 1,
                    ;Autovector=ON,avect 24+2=26,

move.b  %#10001010,D0 ;set up MBUS Interrupt
move.b  D0,ICR11     ;Level 2 interrupt, Priority 2,
                    ;Autovector=On,AVECT 24+3 = 27

move.b  %#00011011,D0 ;set up UART1 Interrupt
move.b  D0,ICR12     ;Level 6 interrupt, Priority 3,
                    ;Autovector=Off

move.b  %#00001001,D0 ;set up UART2 Interrupt
move.b  D0,ICR13     ;Level 1 interrupt, Priority 1,
                    ;Autovector=Off
```

Timer 1*TMR register*

Bits 15:8 sets the prescale to 256 (\$FF)

Bits 7:6 set for no interrupt ("00")

Bits 5:4 sets output mode for "toggle". No interrupts("10")

Bits 3 set for "restart" ("1")

Bits 2:1 set the clocking source to system clock/16 ("10")

Bit 0 enables/disables the timer ("0")

```

move.w  #$FF2C,D0          ;Setup the Timer mode register (TMR1)
move.w  D0,TMR1 ;;        Bit 1 is set to 0 to disable the timer
move.w  #$0000,D0          ; writing to the timer counter with any value resets it
to zero
move.w  D0,TCN1 ;

```

TRR1 register

The TRR register is set to \$AFAF. The timer will count up to this value (TCN = TRR), toggle the "TOUT" pin, and reset the TCN to \$0000.

```

move.w  #$AFAF,D0          ;Setup the Timer reference register (TRR1)
move.w  D0,TRR1

```

Other registers used for TIMER 1

TCR1 ;TIMER1 Capture Register, 16-bit, R

TER1 ;TIMER1 Event Register, 8-bit, R/W

Timer 2*TMR2 register*

Bits 15:8 set the prescale to 127 (\$7F)

Bits 7:6 set the capture mode and interrupt ("00")

Bits 5:4 set the output mode for "pulse" and no interrupt ("00")

Bits 3 set for free-running ("0")

Bits 2:1 set the clocking source to clk/16 ("10")

Bit 1 enables the timer ("0")

```
move.w  #$7F04,D0      ;Setup the Timer mode register (TMR2)
move.w  D0,TMR2 ;
```

```
move.w  #$1234,D0      ;Set the Timer reference to $1234
move.w  D0,TRR2 ;
```

```
move.w  #$0000,D0      ;writing to the timer counter with
move.w  D0,TCN2 ;      any value resets it to zero
```

Other registers used

TCR2 ;TIMER2 Capture Register, 16-bit, R

TER2 ;TIMER2 Event Register, 8-bit, R/W

SECTION 15 DEBUG SUPPORT

This section details the hardware debug support functions within the ColdFire[®] 5200 Family of processors.

The general topic of debug support is divided into three separate areas:

1. Real-Time Trace Support
2. Background Debug Mode (BDM)
3. Real-Time Debug Support

Each of the three areas is addressed in detail in the following subsections.

The logic required to support these three areas is contained in a debug module, which is shown in the system block diagram in Figure 15-1.

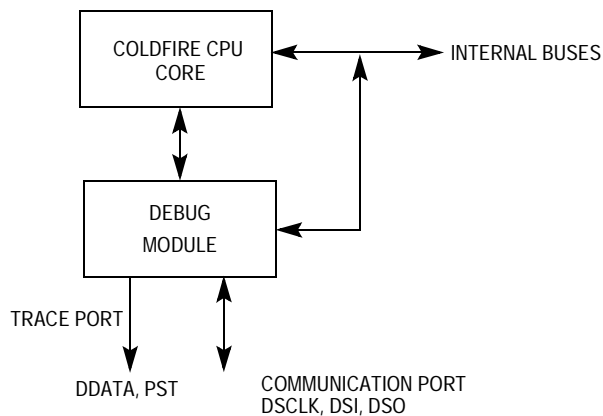

Figure 15-1. Processor/Debug Module Interface

15.1 REAL-TIME TRACE

In the area of debug functions, one fundamental requirement is support for real-time trace functionality (i.e., definition of the dynamic execution path). The ColdFire Family solution is to include a parallel output port providing encoded processor status and data to an external development system. This port is partitioned into two 4-bit nibbles: one nibble allows the processor to transmit information concerning the execution status of the core (processor status, PST[3:0]), while the other nibble allows data to be displayed (debug data, DDATA[3:0]).

The processor status timing is synchronous with the processor clock (CLK) and the status may not be related to the current bus transfer. Table 15-1 below shows the encodings of these signals.

Table 15-1. Processor PST Definition

PST[3:0]		DEFINITION
(HEX)	(BINARY)	
\$0	0000	Continue execution
\$1	0001	Begin execution of an instruction
\$2	0010	Reserved
\$3	0011	Entry into user-mode
\$4	0100	Begin execution of PULSE or WDDATA instruction
\$5	0101	Begin execution of taken branch
\$6	0110	Reserved
\$7	0111	Begin execution of RTE instruction
\$8	1000	Begin 1-byte transfer on DData
\$9	1001	Begin 2-byte transfer on DData
\$A	1010	Begin 3-byte transfer on DData
\$B	1011	Begin 4-byte transfer on DData
\$C	1100	† Exception processing
\$D	1101	† Emulator-mode entry exception processing
\$E	1110	† Processor is stopped, waiting for interrupt
\$F	1111	† Processor is halted

† These encodings are asserted for multiple cycles.

The processor status outputs can be used with an external image of the program to completely track the dynamic execution path of the machine. The tracking of this dynamic path is complicated by any change-of-flow operation. Within the ColdFire instruction set architecture, most branch instructions are implemented using PC-relative addressing. Accordingly, the external program image can determine branch target addresses. Additionally, there are a number of instructions that use some type of variant addressing, i.e., the calculation of the target instruction address is not PC-relative or absolute but involves the use of a program-visible register.

The simplest example of a branch instruction using a variant addressing mode is the compiled code for a C language *case* statement. Typically, the evaluation of this statement uses the variable of an expression as an index into a table of offsets, where each offset points to a unique case within the structure. For these types of change-of-flow operations, the ColdFire processor uses the debug pins to output a sequence of information.

1. Identify a taken branch has been executed using the PST[3:0]=\$5.
2. Using the PST pins, signal the target address is to be displayed on the DDATA pins. The encoding identifies the number of bytes that are displayed and is optional.
3. The new target address is optionally available on subsequent cycles using the nibble-wide DDATA port. The number of bytes of the target address displayed on this port is

a configurable parameter (2, 3, or 4 bytes).

The nibble-wide DDATA port includes two 32-bit storage elements for capturing the CPU core bus information. These two elements effectively form a FIFO buffer connecting the core bus to the external development system. The FIFO buffer captures variant branch target addresses along with certain operand read/write data for eventual display on the DDATA output port. The execution speed of the ColdFire processor is affected only when both storage elements contain valid data waiting to be dumped onto the DDATA port. In this case, the processor core stalls until one FIFO entry is available. In all other cases, data output on the DDATA port does not impact execution speed.

From the processor core perspective, the PST outputs signal the first AGEX cycle of an instruction's execution. Most single-cycle instructions begin and complete their execution within a given machine cycle.

Because the processor status (PST[3:0]) values of \$C, \$D, \$E, and \$F define a multicycle mode or a special operation, the PST outputs are driven with these values until the mode is exited or the operation completed. All the remaining fields specify information that is updated each machine cycle.

The status values of \$8, \$9, \$A, and \$B qualify the contents of the DDATA output bus. These encodings are driven onto the PST port one machine cycle before the actual data is displayed on DDATA.

Figure15-2 shows the execution of an indirect JMP instruction with the lower 16 bits of the target address being displayed on the DDATA output. In this diagram, the indirect JMP branches to address "target." The processor internally forms the PST marker (\$9) one cycle before the address begins to appear on the DDATA port. The target address is displayed on DDATA for four consecutive clocks, starting with the least-significant nibble. The processor continues execution, unaffected by the DDATA bus activity.

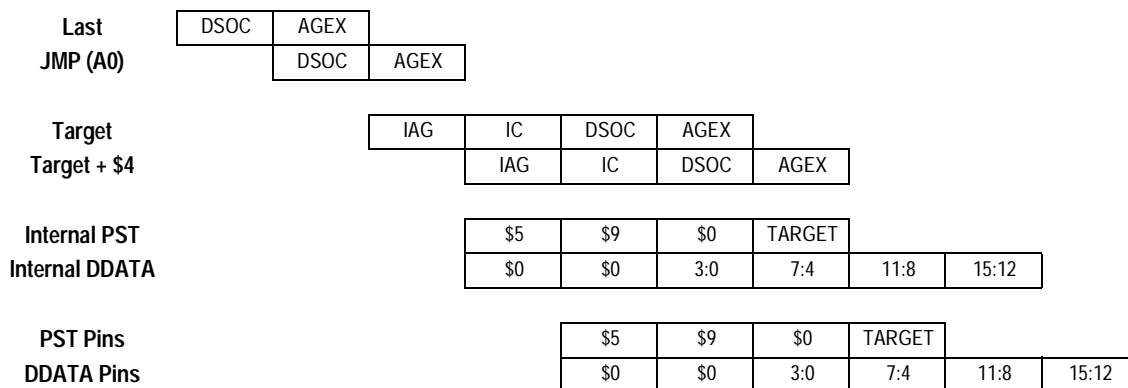

Figure 15-2. Pipeline Timing Example (Debug Output)

The ColdFire instruction set architecture (ISA) includes a PULSE opcode. This opcode generates a unique PST encoding when executed (PST = \$4). This instruction can define logic analyzer triggers for debug and/or performance analysis.

Additionally, a WDDATA opcode is supported that lets the processor core write any operand (byte, word, longword) directly to the DDATA port, independent of any Debug module configuration. This opcode also generates the special PST = \$4 encoding when executed.

15.2 BACKGROUND DEBUG MODE (BDM)

ColdFire 5200 processors support a modified version of the BDM functionality found on Motorola's CPU32 Family of parts. BDM implements a low-level system debugger in the microprocessor hardware. Communication with the development system is handled via a dedicated, high-speed serial command interface (BDM port).

Unless noted otherwise, the BDM functionality provided by ColdFire 5200 processors is a proper subset of the CPU32 functionality. The main differences include the following:

- ColdFire implements the BDM controller in a dedicated hardware module. Although some BDM operations do require the CPU to be halted (e.g., CPU register accesses), other BDM commands such as memory accesses can be executed while the processor is running.
- DSCLK, DSI, and DSO are treated as synchronous signals, where the inputs (DSCLK and DSI) must meet the required input setup and hold timings, and the output (DSO) is specified as a delay relative to the rising edge of the processor clock.
- On CPU32 parts, DSO could signal hardware that a serial transfer can start. ColdFire clocking schemes restrict the use of this bit. Because DSO changes only when DSCLK is high, DSO cannot be used to indicate the start of a serial transfer. The development system should use either a free-running DSCLK or count the number of clocks in any given transfer.
- The Read/Write System Register commands (RSREG/WSREG) have been replaced by Read/Write Control Register commands (RCREG/WCREG). These commands use the register coding scheme from the MOVEC instruction.
- Read/Write Debug Module Register commands (RDMREG/WDMREG) have been added to support Debug module register accesses.
- CALL and RST commands are not supported.
- Illegal command responses can be returned using the FILL and DUMP commands.
- For any command performing a byte-sized memory read operation, the upper 8 bits of the response data are undefined. The referenced data is returned in the lower 8 bits of the response.
- The debug module forces alignment for memory-referencing operations: long accesses are forced to a 0-modulo-4 address; word accesses are forced to a 0-modulo-2 address. An address error response can no longer be returned.

15.2.1 CPU Halt

Although some BDM operations can occur in parallel with CPU operation, unrestricted BDM operation requires the CPU to be halted. A number of sources can cause the CPU to halt, including the following (as shown in order of priority):

1. The occurrence of the catastrophic fault-on-fault condition automatically halts the processor. The halt status is posted on the PST port (\$F).
2. The occurrence of a hardware breakpoint (reference subsection **Section 15.3 Realtime Debug Support**) can be configured to generate a pending halt condition in a manner similar to the assertion of the $\overline{\text{BKPT}}$ signal. In some cases, the occurrence of this type of breakpoint halts the processor in an imprecise manner. Once the hardware breakpoint is asserted, the processor halts at the next sample point. See **Section 15.3.2 Theory of Operation** for more detail.
3. The execution of the HALT (also known as BGND on the 683xx devices) instruction immediately suspends execution and posts the halt status (\$F) on the PST outputs. By default, this is a supervisor instruction and attempted execution while in user mode generates a privilege-violation exception. A User Halt Enable (UHE) control bit is provided in the Configuration/Status Register (CSR) to allow execution of HALT in user mode.
4. The assertion of the $\overline{\text{BKPT}}$ input pin is treated as an pseudo-interrupt, i.e., the halt condition is made pending until the processor core samples for halts/interrupts. The processor samples for these conditions once during the execution of each instruction. If there is a pending halt condition at the sample time, the processor suspends execution and enters the halted state. The halt status (\$F) is reflected in the PST outputs.

The halt source is indicated in CSR[27:24]; for simultaneous halt conditions, the highest priority source is indicated.

There are two special cases to be considered that involve the assertion of the $\overline{\text{BKPT}}$ pin.

After $\overline{\text{RSTI}}$ is negated, the processor waits for 16 clock cycles before beginning reset exception processing. If the $\overline{\text{BKPT}}$ input pin is asserted within the first eight cycles after $\overline{\text{RSTI}}$ is negated, the processor enters the halt state, signaling that status on the PST outputs (\$F). While in this state, all resources accessible via the Debug module can be referenced. Once the system initialization is complete, the processor response to a BDM GO command depends on the set of BDM commands performed while “breakpointed.” Specifically, if the processor’s PC register was loaded, the GO command causes the processor to exit the halt state and pass control to the instruction address contained in the PC. In this case, the normal reset exception processing is bypassed. Conversely, if the PC register was not loaded, the GO BDM command causes the processor to exit the halt state and continue with reset exception processing.

ColdFire 5200 processors also handle a special case with the assertion of $\overline{\text{BKPT}}$ while the processor is stopped by execution of the STOP instruction. For this case when the $\overline{\text{BKPT}}$ is asserted, the processor exits the stopped mode and enters the halted state. Once halted, the standard BDM commands may be exercised. When the processor is restarted, it continues with the execution of the next sequential instruction, i.e., the instruction following the STOP opcode.

The Debug module Configuration/Status Register (CSR) maintains status defining the condition that caused the CPU to halt.

15.2.2 BDM Serial Interface

Once the CPU is halted and the halt status reflected on the PST outputs (PST[3:0]=\$F), the development system can send unrestricted commands to the Debug module. The Debug module implements a synchronous protocol using a three-pin interface: development serial clock (DSCLK), development serial input (DSI), and development serial output (DSO). The development system serves as the serial communication channel master and is responsible for generation of the clock (DSCLK). The operating range of the serial channel is DC to one-half of the processor frequency. The channel uses a full duplex mode, where data is transmitted and received simultaneously by both master and slave devices.

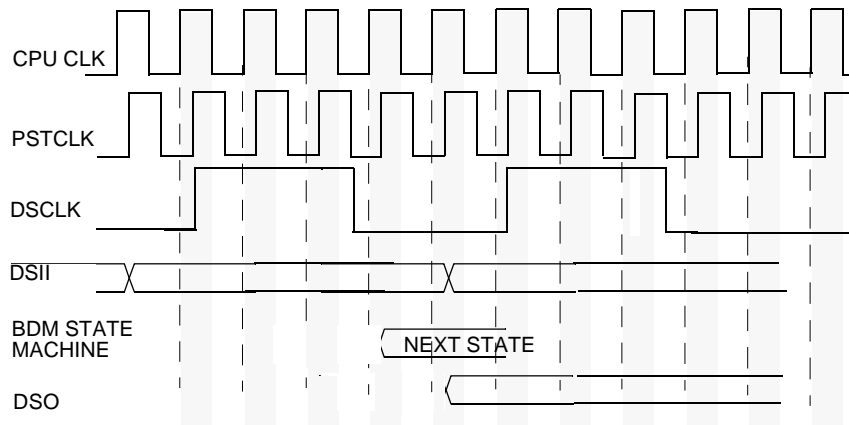

Figure 15-3. DBM Serial Transfer

Both DSCLK and DSI are synchronous inputs and must meet input setup and hold times with respect to CLK. DSCLK essentially acts as a pseudo “clock enable” and is sampled on the rising edge of CLK. If the setup time of DSCLK is met, then the internal logic transitions on the rising edge of CLK, and DSI is sampled on the same CLK rising edge. The DSO output is specified as a delay from the DSCLK-enabled CLK rising edge. All events in the

Debug module's serial state machine are based on the rising edge of the microprocessor clock. Refer to **Section 17: Electrical Characteristics**.

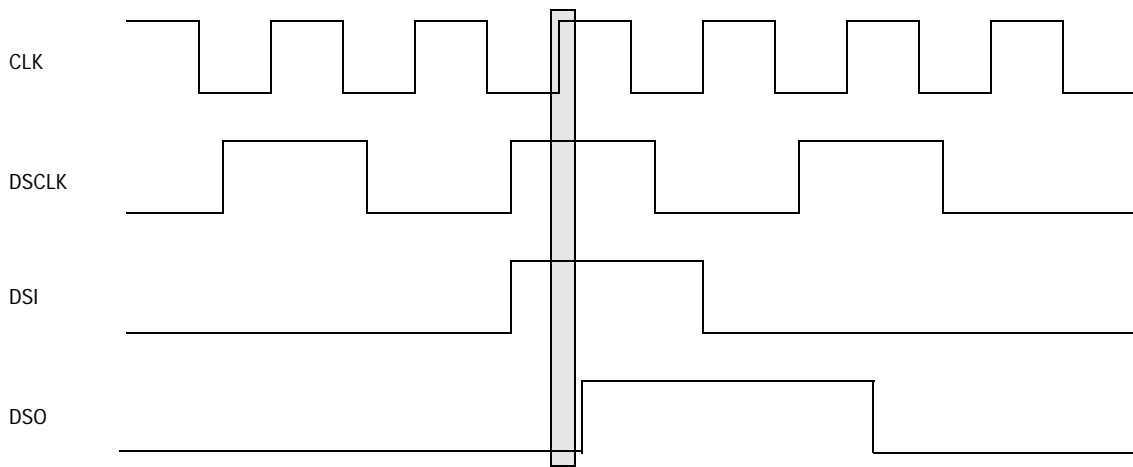

Figure 15-4. BDM Signal Sampling

The basic packet of information is a 17-bit word (16 data bits plus a status/control bit), as shown here.



Status/Control

The status/control bit indicates the status of CPU-generated messages (always single word with the data field encoded as listed in Table 15-2). Command and data transfers initiated by the development system should clear bit 16. The current implementation ignores this bit; however, Motorola has reserved this bit for future enhancements.

Table 15-2. CPU-Generated Message Encoding

S/C BIT	DATA	MESSAGE TYPE
0	xxxx	Valid data transfer
0	\$FFFF	Command complete; status OK
1	\$0000	Not ready with response; come again
1	\$0001	TEA-terminated bus error cycle; data invalid
1	\$FFFF	Illegal command

Data Field

The data field contains the message data to be communicated between the development system and the Debug module.

15.2.3 BDM Command Set

ColdFire 5200 processors support a subset of BDM instructions from the current 683xx parts as well as extensions to provide access to new hardware features.

15.2.3.1 BDM COMMAND SET SUMMARY. The BDM command set is summarized in Table 15-3. Subsequent paragraphs contain detailed descriptions of each command.

Table 15-3. BDM Command Summary

COMMAND	MNEMONIC	DESCRIPTION	CPUMPACT ¹
Read A/D Register	RAREG/RDREG	Read the selected address or data register and return the result via the serial BDM interface	Halted
Write A/D Register	WAREG/WDREG	The data operand is written to the specified address or data register via the serial BDM interface	Halted
Read Memory Location	READ	Read the sized data at the memory location specified by the longword address	Cycle Steal
Write Memory Location	WRITE	Write the operand data to the memory location specified by the longword address	Cycle Steal
Dump Memory Block	DUMP	Used in conjunction with the READ command to dump large blocks of memory. An initial READ is executed to set up the starting address of the block and to retrieve the first result. Subsequent operands are retrieved with the DUMP command.	Cycle Steal
Fill Memory Block	FILL	Used in conjunction with the WRITE command to fill large blocks of memory. An initial WRITE is executed to set up the starting address of the block and to supply the first operand. Subsequent operands are written with the FILL command.	Cycle Steal
Resume Execution	GO	The pipeline is flushed and refilled before resuming instruction execution at the current PC	Halted
No Operation	NOP	NOP performs no operation and may be used as a null command	Parallel
Read Control Register	RCREG	Read the system control register	Halted
Write Control Register	WCREG	Write the operand data to the system control register	Halted
Read Debug Module Register	RDMREG	Read the Debug module register	Parallel
Write Debug Module Register	WDMREG	Write the operand data to the Debug module register	Halted
NOTE: 1. <i>General</i> command effect and/or requirements on CPU operation: Halted - The CPU must be halted to perform this command Steal - Command generates a bus cycle which is interleaved with CPU accesses Parallel - Command is executed in parallel with CPU activity Refer to command summaries for detailed operation descriptions.			

15.2.3.2 COLD FIRE BDM COMMANDS. All ColdFire Family BDM commands include a 16-bit operation word followed by an optional set of one or more extension words.

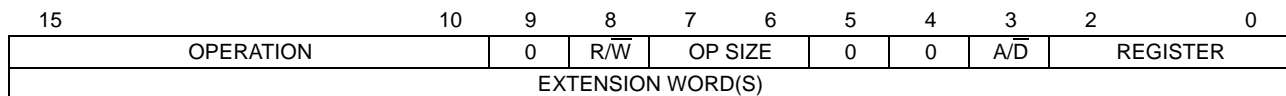

Operation Field

The operation field specifies the command.

R/W Field

The R/W field specifies the direction of operand transfer. When the bit is set, the transfer is from the CPU to the development system. When the bit is cleared, data is written to the CPU or to memory from the development system.

Operand Size

For sized operations, this field specifies the operand data size. All addresses are expressed as 32-bit absolute values. The size field is encoded as listed in Table 15-4.

Table 15-4. BDM Size Field Encoding

ENCODING	OPERAND SIZE	BIT VALUES
00	Byte	8 bits
01	Word	16 bits
10	Long	32 bits
11	Reserved	

Address / $\overline{\text{Data}}$ (A/\overline{D}) Field

The A/\overline{D} field is used in commands that operate on address and data registers in the processor. It determines whether the register field specifies a data or address register. A one indicates an address register; zero, a data register.

Register Field

In commands that operate on processor registers, this field specifies which register is selected. The field value contains the register number.

Extension Word(s) (as required):

Certain commands require extension words for addresses and/or immediate data. Addresses require two extension words because only absolute long addressing is permitted. Immediate data can be either one or two words in length; byte and word data each require a single extension word; longword data requires two words. Both operands and addresses are transferred by most significant word first. In the following descriptions of the BDM command set, the optional set of extension words are defined as the “Operand Data.”

15.2.3.3 Command Sequence Diagram. A command sequence diagram (see Figure 14-4) illustrates the serial bus traffic for each command. Each bubble in the diagram represents a single 16-bit transfer across the bus. The top half in each diagram corresponds to the data transmitted by the development system to the debug module; the bottom half corresponds to the data returned by the debug module in response to the development system commands. Command and result transactions are overlapped to minimize latency.

The cycle in which the command is issued contains the development system command mnemonic (in this example, “read memory location”). During the same cycle, the debug module responds with either the lowest order results of the previous command or with a command complete status (if no results were required).

During the second cycle, the development system supplies the high-order 16 bits of the memory address. The Debug module returns a “not ready” response (\$10000) unless the received command was decoded as unimplemented, in which case the response data is the illegal command (\$1FFFF) encoding. If an illegal command response occurs, the development system should retransmit the command.

NOTE

The “not ready” response is ignored unless a memory bus cycle is in progress. Otherwise, the debug module can accept a new serial transfer after eight system clock periods.

In the third cycle, the development system supplies the low-order 16 bits of a memory address. The debug module always returns the “not ready” response in this cycle. At the completion of the third cycle, the debug module initiates a memory read operation. Any serial transfers that begin while the memory access is in progress return the “not ready” response.

Results are returned in the two serial transfer cycles following the completion of memory access. The data transmitted to the debug module during the final transfer is the opcode for the following command. Should a memory access generate a bus error, an error status (\$10001) is returned in place of the result data.

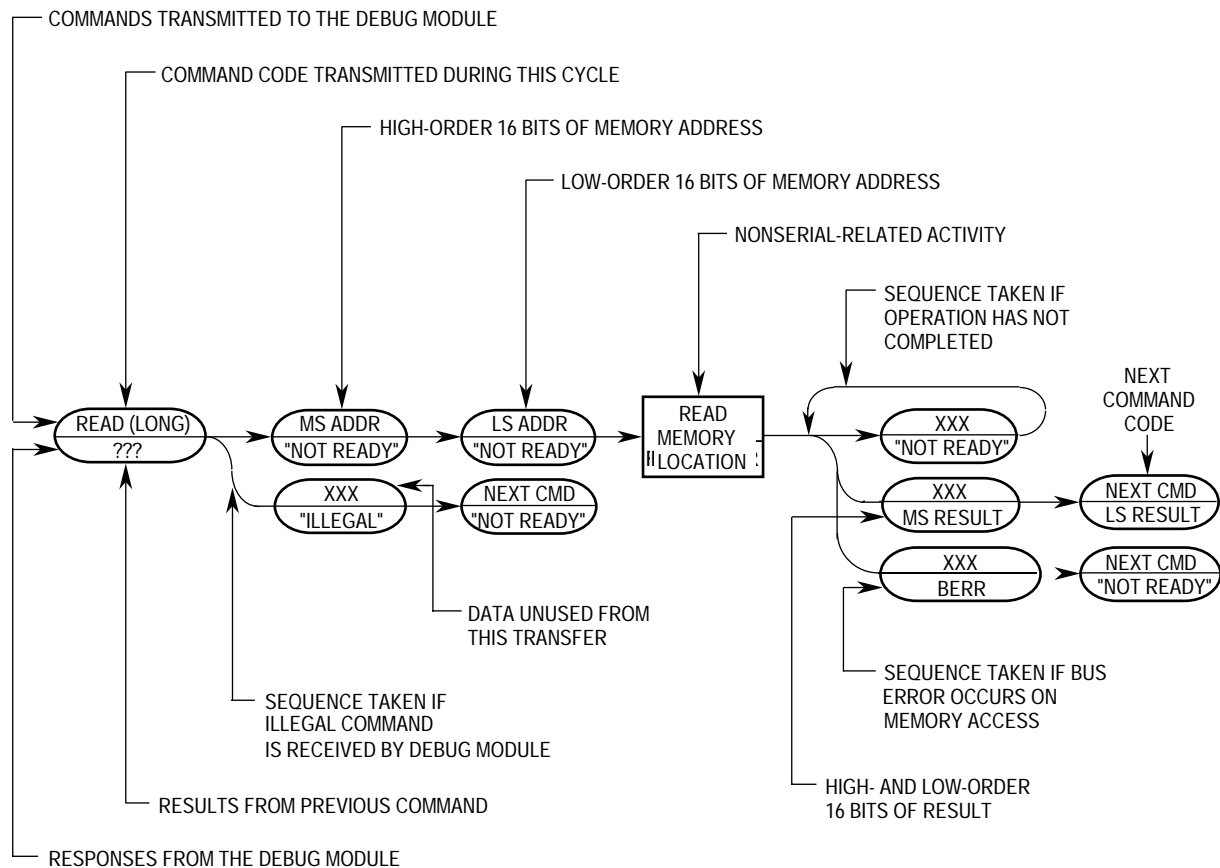

Figure 15-5. Command Sequence Diagram

15.2.3.4 Command Set Descriptions. The BDM command set is summarized in Table 15-3.

Freescale Semiconductor, Inc.

Note

All the accompanying valid BDM results are defined with the most significant bit of the 17-bit response (S/C) as 0. Invalid command responses (Not Ready; TEA-terminated bus cycle; Illegal Command) return a 1 in the most significant bit of the 17-bit response (S/C).

Motorola reserves unassigned command opcodes for future expansion. All unused command formats within any revision level will perform a NOP and return the ILLEGAL command response.

15.2.3.4.1 Read A/D Register (RAREG/RDREG). Read the selected address or data register and return the 32-bit result. A bus error response is returned if the CPU core is not halted.

Formats:

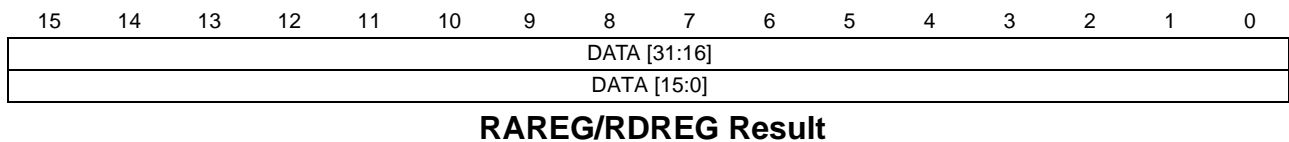
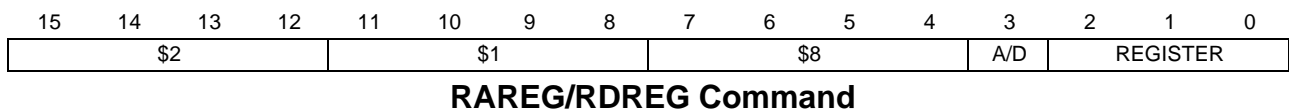

Command Sequence:

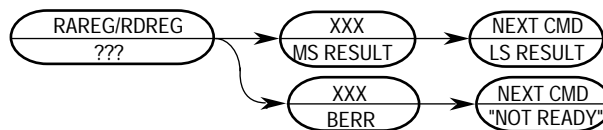

Operand Data:
None

Result Data:
The contents of the selected register are returned as a longword value. The data is returned most significant word first.

15.2.3.4.2 Write A/D Register (WAREG/WDREG). The operand (longword) data is written to the specified address or data register. All 32 register bits are altered by the write. A bus error response is returned if the CPU core is not halted.

Freescale Semiconductor, Inc.

Command Formats:

15	14	13	12	11	10	9	8	7	6	5	4	3	2	1	0	
\$2				\$0				\$8				A/D	REGISTER			
DATA [31:16]																
DATA [15:0]																

WAREG/WDREG Command

Command Sequence:

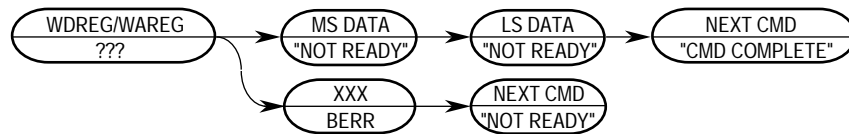

Operand Data:

Longword data is written into the specified address or data register. The data is supplied most significant word first.

Result Data:

Command complete status (\$0FFFF) is returned when register write is complete.

15.2.3.4.3 Read Memory Location (READ). Read the operand data from the memory location specified by the longword address. The address space is defined by the contents of the low-order 5 bits {TT, TM} of the address attribute register (AATR). The hardware forces the low-order bits of the address to zeros for word and longword accesses to ensure that operands are always accessed on natural boundaries: words on 0-modulo-2 addresses, longwords on 0-modulo-4 addresses.

Formats:

15	14	13	12	11	10	9	8	7	6	5	4	3	2	1	0
\$1				\$9				\$0				\$0			
ADDRESS [31:16]															
ADDRESS [15:0]															

Byte READ Command

15	14	13	12	11	10	9	8	7	6	5	4	3	2	1	0
X	X	X	X	X	X	X	X	DATA [7:0]							

Byte READ Result

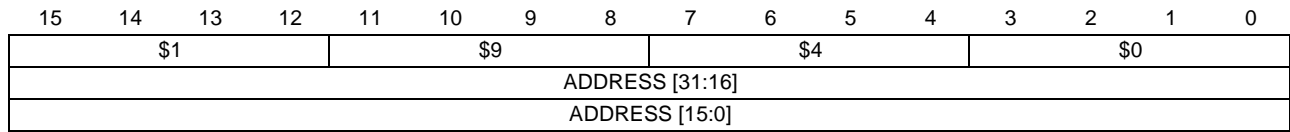

Word READ Command

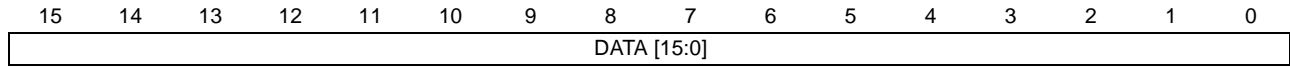

Word READ Result

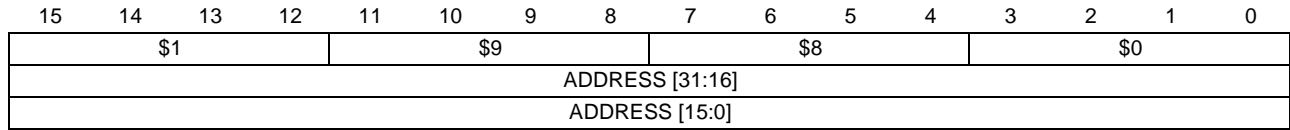

Long READ Command

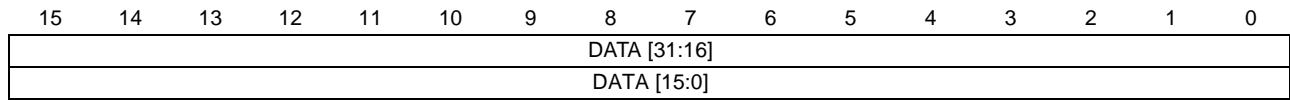

Long READ Result

Command Sequence:

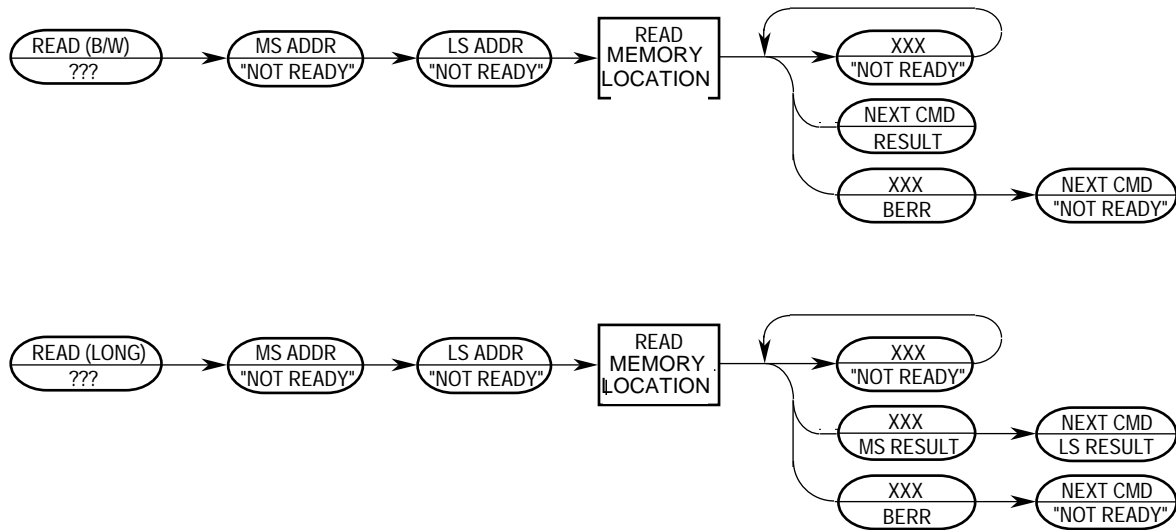

Operand Data:

The single operand is the longword address of the requested memory location.

Result Data:

The requested data is returned as either a word or longword. Byte data is returned in the least significant byte of a word result, with the upper byte undefined. Word results return 16

bits of significant data; longword results return 32 bits.

A successful read operation returns data bit 16 cleared. If a bus error is encountered, the returned data is \$10001.

15.2.3.4.4 Write Memory Location (WRITE). Write the operand data to the memory location specified by the longword address. The address space is defined by the contents of the low-order 5 bits {TT, TM} of the address attribute register (AATR). The hardware forces the low-order bits of the address to zeros for word and longword accesses to ensure that operands are always accessed on natural boundaries: words on 0-modulo-2 addresses, longwords on 0-modulo-4 addresses.

Formats:

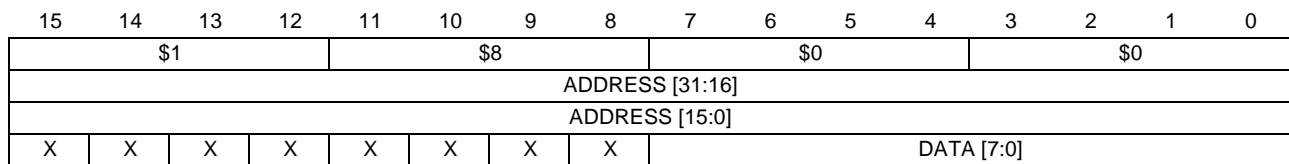

Byte WRITE Command

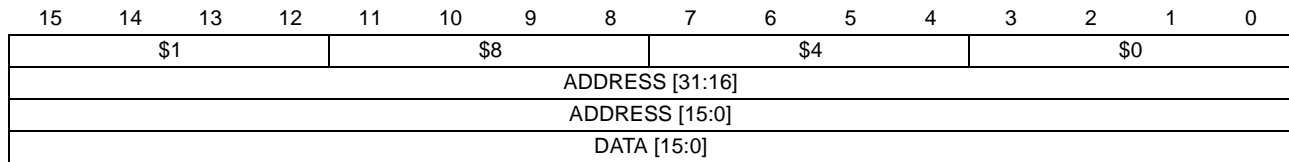

Word WRITE Command

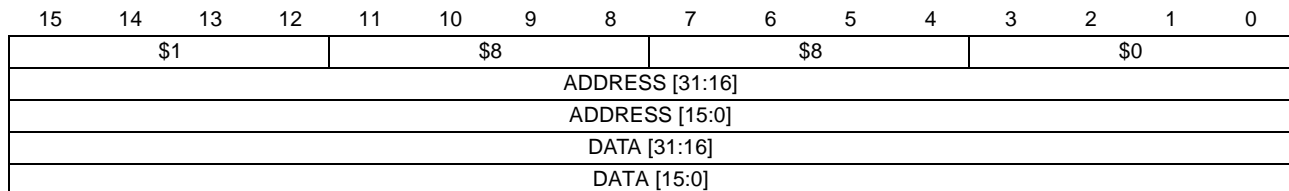

Long WRITE Command

Command Sequence:

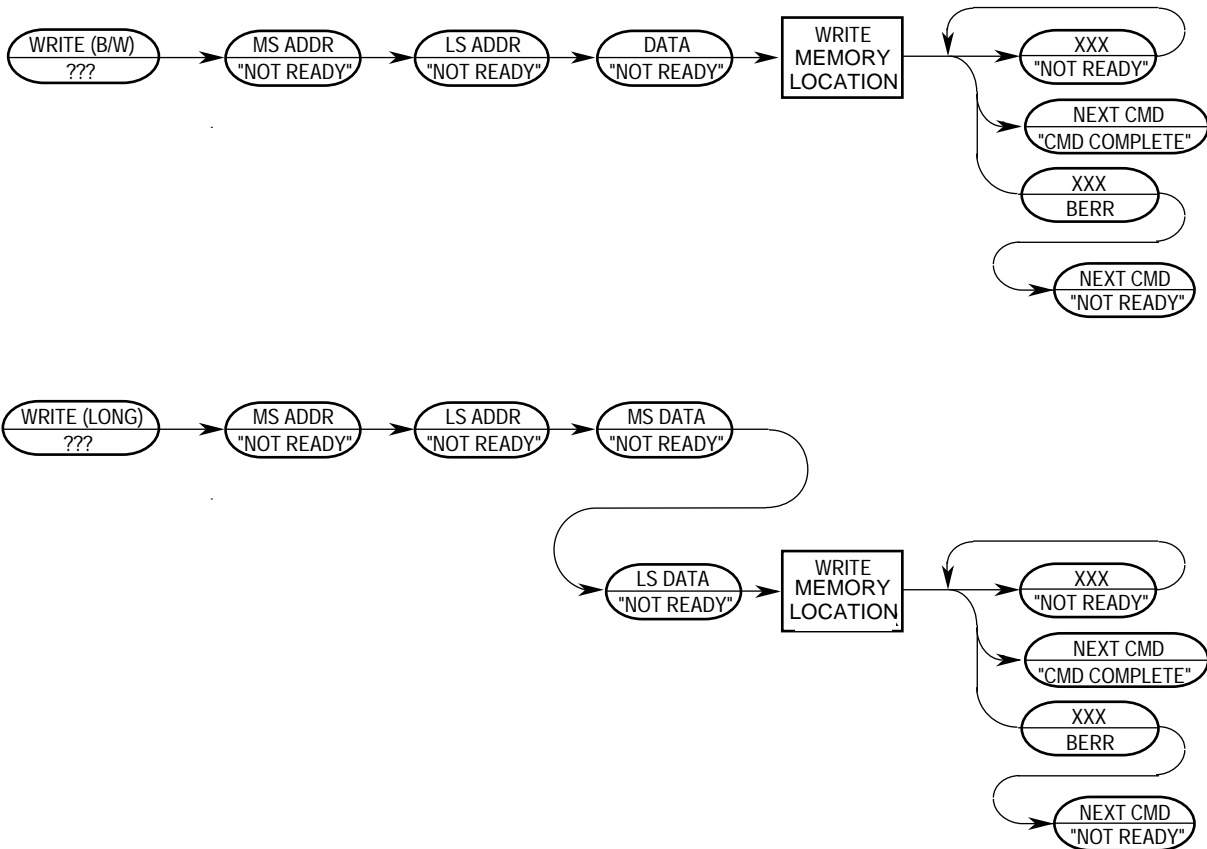

Operand Data:

Two operands are required for this instruction. The first operand is a longword absolute address that specifies a location to which the operand data is to be written. The second operand is the data. Byte data is transmitted as a 16-bit word, justified in the least significant byte; 16- and 32-bit operands are transmitted as 16 and 32 bits, respectively.

Result Data:

Successful write operations return a status of \$0FFFF. A bus error on the write cycle is indicated by the assertion of bit 16 in the status message and by a data pattern of \$0001.

15.2.3.4.5 Dump Memory Block (DUMP). DUMP is used in conjunction with the READ command to dump large blocks of memory. An initial READ is executed to set up the starting address of the block and to retrieve the first result. The DUMP command retrieves subsequent operands. The initial address is incremented by the operand size (1, 2, or 4) and saved in a temporary register (Address Breakpoint High (ABHR)). Subsequent DUMP

commands use this address, perform the memory read, increment it by the current operand size, and store the updated address in ABHR.

NOTE

The DUMP command does not check for a valid address in ABHR—DUMP is a valid command only when preceded by another DUMP, NOP or by a READ command. Otherwise, an illegal command response is returned. The NOP command can be used for intercommand padding without corrupting the address pointer.

The size field is examined each time a DUMP command is given, allowing the operand size to be dynamically altered.

Command Formats:

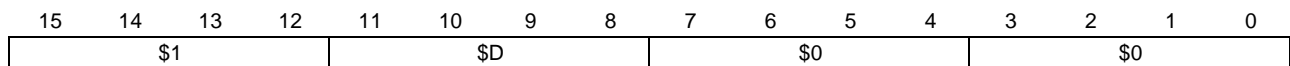

Byte DUMP Command

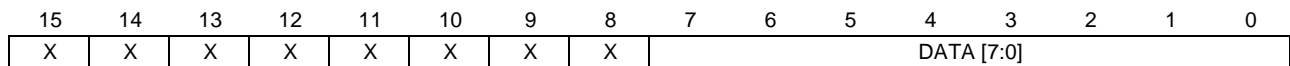

Byte DUMP Result

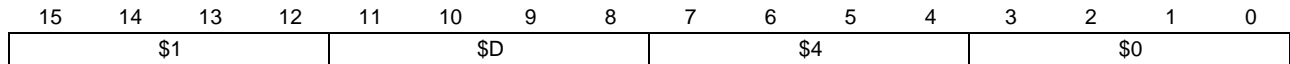

Word DUMP Command

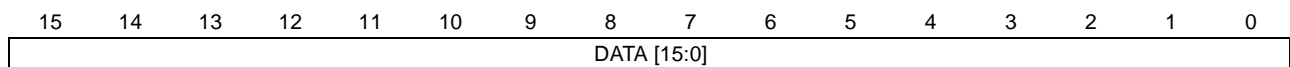

Word DUMP Result

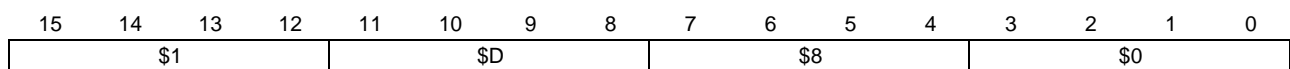

Long DUMP Command

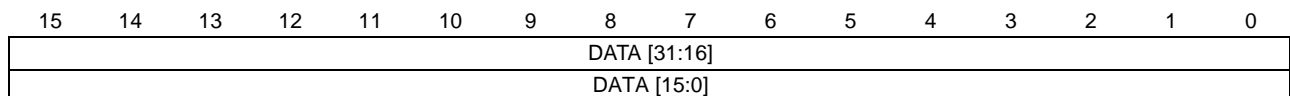

Long DUMP Result

Command Sequence:

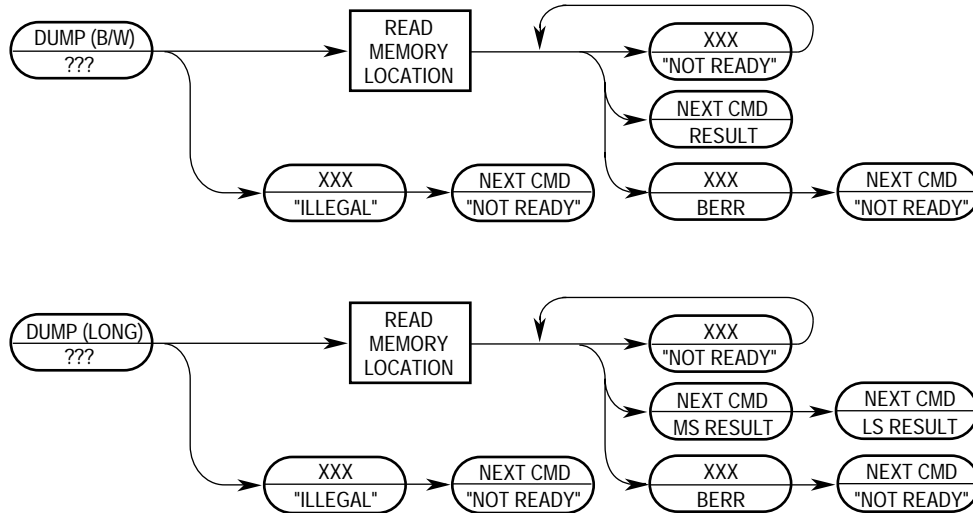

Operand Data:

None

Result Data:

Requested data is returned as either a word or longword. Byte data is returned in the least significant byte of a word result. Word results return 16 bits of significant data; longword results return 32 bits. Status of the read operation is returned as in the READ command: \$0xxxx for success, \$10001 for a bus error.

15.2.3.4.6 Fill Memory Block (FILL). FILL is used in conjunction with the WRITE command to fill large blocks of memory. An initial WRITE is executed to set up the starting address of the block and to supply the first operand. The FILL command writes subsequent operands. The initial address is incremented by the operand size (1, 2, or 4) and is saved in ABHR after the memory write. Subsequent FILL commands use this address, perform the write, increment it by the current operand size, and store the updated address in ABHR.

NOTE

The FILL command does not check for a valid address in ABHR—FILL is a valid command only when preceded by another FILL, NOP or by a WRITE command. Otherwise, an illegal command response is returned. The NOP command can be used for intercommand padding without corrupting the address pointer.

The size field is examined each time a FILL command is processed, allowing the operand size to be altered dynamically.

Formats:

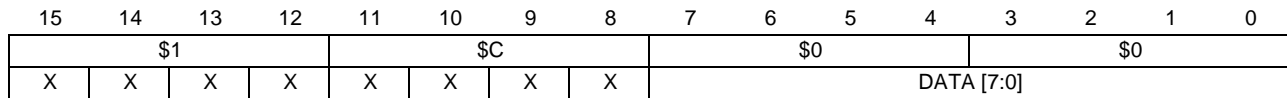

Byte FILL Command

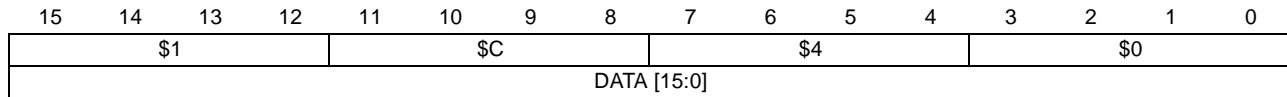

Word FILL Command

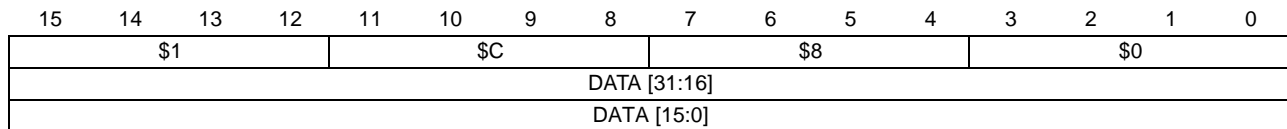

Long FILL Command

Command Sequence:

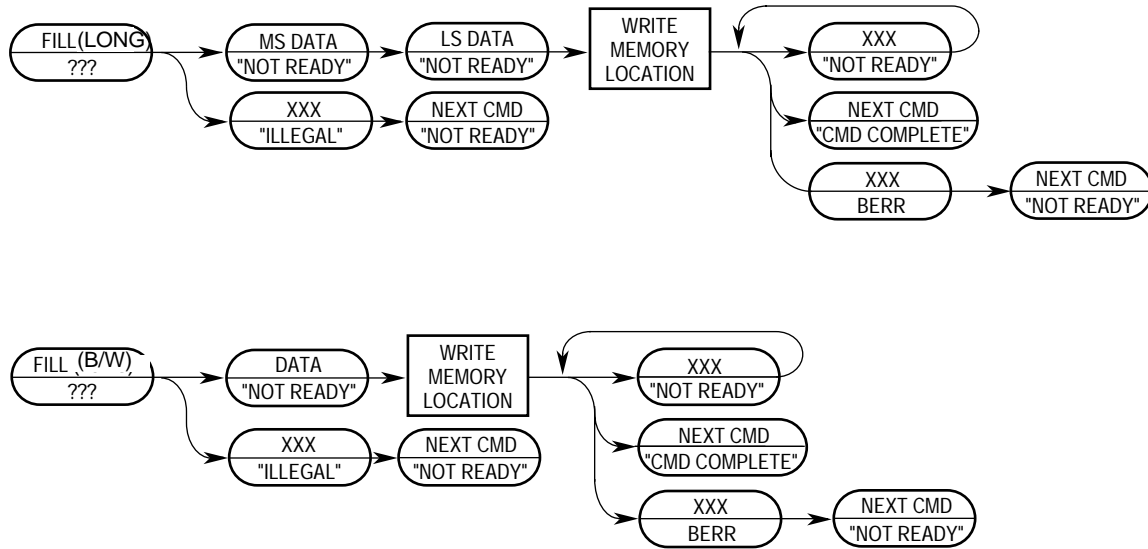

Operand Data:

A single operand is data to be written to the memory location. Byte data is transmitted as a 16-bit word, justified in the least significant byte; 16- and 32-bit operands are transmitted as 16 and 32 bits, respectively.

Result Data:

Status is returned as in the WRITE command: \$0FFFF for a successful operation and \$10001 for a bus error during a write.

15.2.3.4.7 Resume Execution (GO). The pipeline is flushed and refilled before resuming normal instruction execution. Prefetching begins at the current PC and current privilege level. If either the PC or SR is altered during BDM, the updated value of these registers is used when prefetching begins.

Formats:

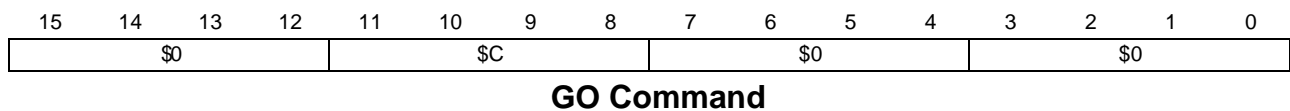

Command Sequence:

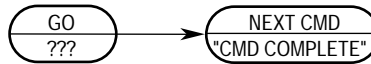

Operand Data:

None

Result Data:

The “command complete” response (\$0FFFF) is returned during the next shift operation.

15.2.3.4.8 No Operation (NOP). NOP performs no operation and can be used as a null command, where required.

Formats:

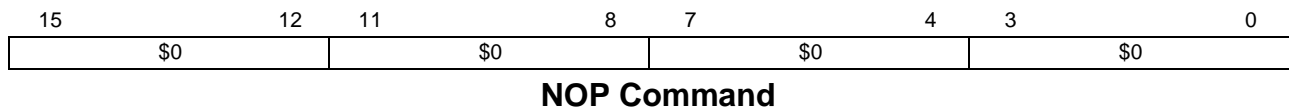

Command Sequence:

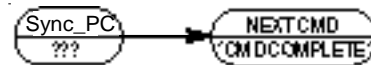

Operand Data:

None

Result Data:

The “command complete” response (\$0FFFF) is returned during the next shift operation.

15.2.3.4.9 Read Control Register (RCREG). Read the selected control register and return the 32-bit result. Accesses to the processor/memory control registers are always 32 bits in size, regardless of the implemented register width. The second and third words of the command effectively form a 32-bit address the Debug module uses to generate a special bus cycle to access the specified control register. The 12-bit Rc field is the same as that used by the MOVEC instruction.

Formats

15	14	13	12	11	10	9	8	7	6	5	4	3	2	1	0
\$2				\$9				\$8				\$0			
\$0				\$0				\$0				\$0			
\$0				RC											

RCREG Command

15	14	13	12	11	10	9	8	7	6	5	4	3	2	1	0
DATA [31:16]															
DATA [15:0]															

RCREG Result

Rc encoding:

Table 15-5. Control Register Map

Rc	REGISTER DEFINITION
\$002	Cache Control Register (CACR)
\$004	Access Control Unit 0 (ACR0)
\$005	Access Control Unit 1 (ACR1)
\$801	Vector Base Register (VBR)
\$80E	Status Register (SR)
\$80F	Program Counter (PC)
\$C04	RAM Base Address Register (RAMBAR)
\$C0F	Module Base Address Register (MBAR)

Command Sequence:

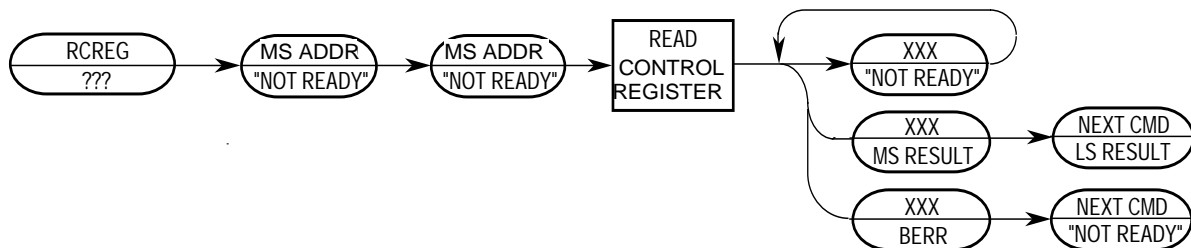

Operand Data:

The single operand is the 32-bit Rc control register select field.

Result Data:

The contents of the selected control register are returned as a longword value. The data is returned by most significant word first. For those control register widths less than 32 bits, only the implemented portion of the register is guaranteed to be correct. The remaining bits

of the longword are undefined. As an example, a read of the 16-bit SR returns the SR in the lower word and undefined data in the upper word.

15.2.3.4.10 Write Control Register (WCREG). The operand (longword) data is written to the specified control register. The write alters all 32 register bits.

Formats:

15	14	13	12	11	10	9	8	7	6	5	4	3	2	1	0
\$2				\$8				\$8				\$0			
\$0				\$0				\$0				\$0			
\$0				Rc											
DATA [31:16]															
DATA [15:0]															

WCREG Command

Command Sequence:

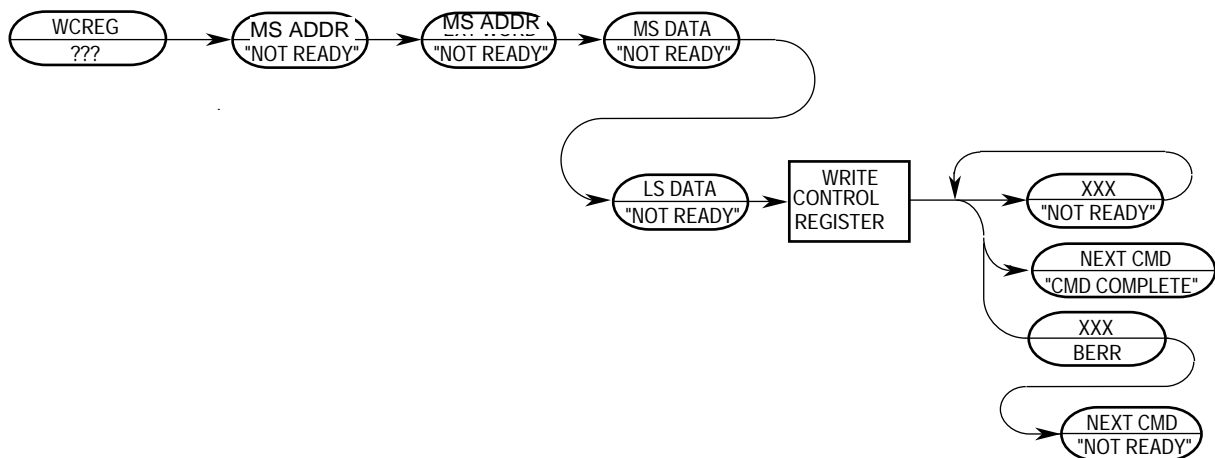

See Table 15-6 for Rc encodings.

Operand Data:

Two operands are required for this instruction. The first long operand selects the register to which the operand data is to be written. The second operand is the data.

Result Data:

Successful write operations return a status of \$0FFFF. Bus errors on the write cycle are indicated by the assertion of bit 16 in the status message and by a data pattern of \$0001.

15.2.3.4.11 Read Debug Module Register (RDMREG). Read the selected Debug Module Register and return the 32-bit result. The only valid register selection for the RDMREG command is the CSR (DRc = \$0).

Command Formats:

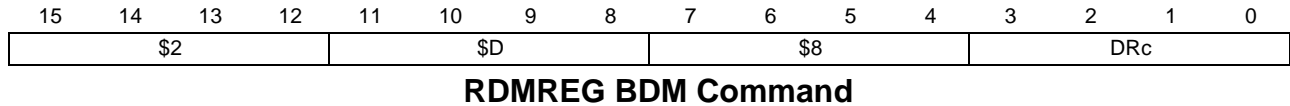

RDMREG BDM Command

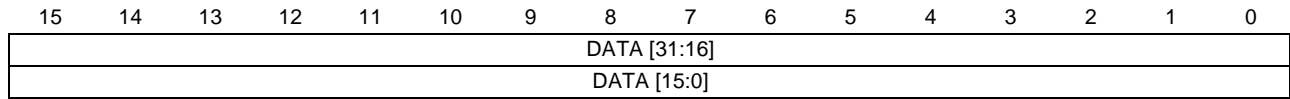

RDMREG BDM Result

DRc encoding:

Table 15-6. Definition of DRc Encoding - Read

DRC[3:0]	DEBUG REGISTER DEFINITION	MNEMONIC	INITIAL STATE
\$0	Configuration/Status	CSR	\$0
\$1-\$F	Reserved	-	-

Command Sequence:

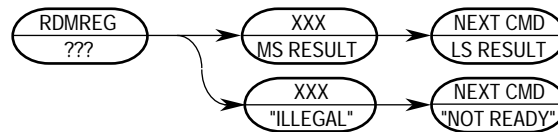

Operand Data:

None

Result Data:

The contents of the selected debug register are returned as a longword value. The data is returned most significant word first.

15.2.3.4.12 Write Debug Module Register (WDMREG). The operand (longword) data is written to the specified Debug Module Register. All 32 bits of the register are altered by the write. The DSCLK signal must be inactive while CPU execution of the WDEBUG instruction is performed.

Command Format:

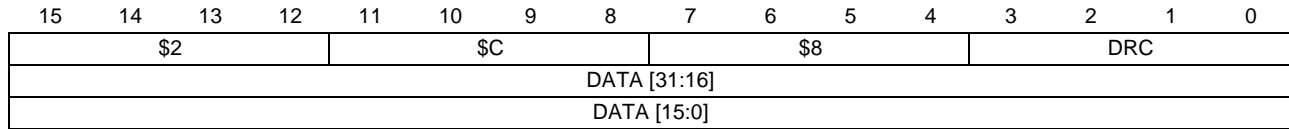

WDMREG BDM Command

DRc encoding:

Table 15-7. Definition of DRc Encoding - Write

DRc[3:0]	DEBUG REGISTER DEFINITION	MNEMONIC	INITIAL STATE
\$0	Configuration/Status	CSR	\$0
\$1-\$5	Reserved	-	-
\$6	Bus Attributes And Mask	AATR	\$0005
\$7	Trigger Definition	TDR	\$0
\$8	PC Breakpoint	PBR	-
\$9	PC Breakpoint Mask	PBMR	-
\$A-\$B	Reserved	-	-
\$C	Operand Address High Breakpoint	ABHR	-
\$D	Operand Address Low Breakpoint	ABLR	-
\$E	Data Breakpoint	DBR	-
\$F	Data Breakpoint Mask	DBMR	-

Command Sequence:

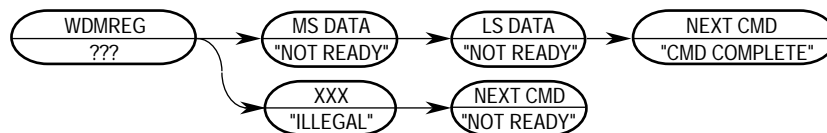

Operand Data:

Longword data is written into the specified debug register. The data is supplied most significant word first.

Result Data:

Command complete status (\$0FFFF) is returned when register write is complete.

15.2.3.4.13 Unassigned Opcodes. Motorola reserves unassigned command opcodes. All unused command formats within any revision level perform a NOP and return the ILLEGAL command response.

15.3 REAL-TIME DEBUG SUPPORT

ColdFire processors provide support for the debug of real-time applications. For these types of embedded systems, the processor cannot be halted during debug but must continue to operate. The foundation of this area of debug support is that while the processor cannot be halted to allow debugging, the system can tolerate small intrusions into the real-time operation.

As discussed in the previous subsection, the debug module provides a number of hardware resources to support various hardware breakpoint functions. Specifically, three types of breakpoints are supported: PC with mask, operand address range, and data with mask. These three basic breakpoints can be configured into one- or two-level triggers with the exact trigger response also programmable.

15.3.1 Theory of Operation

The breakpoint hardware can be configured to respond to triggers in several ways. The desired response is programmed into the Trigger Definition Register. In all situations where a breakpoint triggers, an indication is provided on the `DDATA` output port, when not displaying captured operands or branch addresses, as shown in Table 15-8.

The breakpoint status is also posted in the `CSR`.

The BDM instruction

sampling occurs. For the address and data breakpoints, the reporting is considered imprecise because several additional instructions may be executed after the triggering address or data is seen.

Once the debug interrupt is recognized, the processor aborts execution and initiates exception processing. At the initiation of the exception processing, the core enters emulator mode. After the standard 8-byte exception stack is created, the processor fetches a unique exception vector, 12, from the vector table (Refer to the *ColdFire Programmer's Reference Manual Rev 1.0 MCF5200PRM/AD*).

Execution continues at the instruction address contained in this exception vector. All interrupts are ignored while in emulator mode. You can program the debug-interrupt handler to perform the necessary context saves using the supervisor instruction set. As an example, this handler may save the state of all the program-visible registers as well as the current context into a reserved memory area.

Once the required operations are completed, the return-from-exception (RTE) instruction is executed and the processor exits emulator mode. Once the debug interrupt handler has completed its execution, the external development system can then access the reserved memory locations using the BDM commands to read memory.

If a hardware breakpoint (e.g., a PC trigger) is left unmodified by the debug interrupt service routine, another debug interrupt is generated after the RTE instruction completes execution.

15.3.1.1 EMULATOR MODE. Emulator mode is used to facilitate non-intrusive emulator functionality. This mode can be entered in three different ways:

- The EMU bit in the CSR may be programmed to force the ColdFire processor to begin execution in emulator mode. This bit is only examined when RSTI is negated and the processor begins reset exception processing. It may be set while the processor is halted before the reset exception processing begins. Refer to **Section 15.2.1 CPU Halt**.
- A debug interrupt always enters emulation mode when the debug interrupt exception processing begins.
- The TCR bit in the CSR may be programmed to force the processor into emulation mode when trace exception processing begins.

During emulation mode, the ColdFire processor exhibits the following properties:

- All interrupts are ignored, including level seven.
- If the MAP bit of the CSR is set, all memory accesses are forced into a specially mapped address space signalled by TT = \$2, TM = \$5 or \$6. This includes the stack frame writes and the vector fetch for the exception which forced entry into this mode.
- If the MAP bit in the CSR is set, all caching of memory accesses is disabled. Additionally, the SRAM module is disabled while in this mode.

The return-from-exception (RTE) instruction exits emulation mode. The processor status output port provides a unique encoding for emulator mode entry (\$D) and exit (\$7).

15.3.1.2 DEBUG MODULE HARDWARE.

15.3.1.2.1 Reuse of Debug Module Hardware. The Debug Module implementation provides a common hardware structure for both BDM and breakpoint functionality. Several structures are used for both BDM and breakpoint purposes. Table 15-9 identifies the shared hardware structures.

Table 15-9. Shared BDM/Breakpoint Hardware

REGISTER	BDM FUNCTION	BREAKPOINT FUNCTION
AATR	Bus Attributes for All Memory Commands	Attributes for Address Breakpoint
ABHR	Address for All Memory Commands	Address for Address Breakpoint
DBR	Data for All BDM Write Commands	Data for Data Breakpoint

The shared use of these hardware structures means the loading of the register to perform any specified function is destructive to the shared function. For example, if an operand address breakpoint is loaded into the Debug Module, a BDM command to access memory overwrites the breakpoint. If a data breakpoint is configured, a BDM write command overwrites the breakpoint contents.

15.3.2 Concurrent BDM and Processor Operation

The debug module supports concurrent operation of both the processor and most BDM commands. BDM commands can be executed while the processor is running, except for the operations that access processor/memory registers:

- Read/Write Address and Data Registers
- Read/Write Control Registers

For BDM commands that access memory, the debug module requests the ColdFire core's bus. The processor responds by stalling the instruction fetch pipeline and then waiting until all current core bus activity is complete. At that time, the processor relinquishes the core bus to allow the debug module to perform the required operation. After the conclusion of the Debug module core bus cycle, the processor reclaims ownership of the core bus.

The development system must be careful when configuring the Breakpoint Registers if the processor is executing. The debug module does not contain any hardware interlocks; therefore Motorola recommends that the TDR be disabled while the Breakpoint Registers are being loaded. At the conclusion of this process, the TDR can be written to define the exact trigger. This approach guarantees that no spurious breakpoint triggers occur.

Because there are no hardware interlocks in the debug unit, no BDM operations are allowed while the CPU is writing the Debug Registers (SDSCLK must be inactive).

NOTE

When a BDM command is serially shifted into a ColdFire micro-processor, the debug module requests the use of the internal bus to perform the required operation. Under certain conditions, the processor may never grant the internal bus to the debug module causing the BDM command to never be performed.

Specifically, the internal bus grant may be withheld from the debug module if the processor is executing a tight loop where the entire loop is contained within one aligned longword. Examples include:

```

align4
label1:nop
bra.blable1
OR
align4
label2:bra.wlabel2
    
```

The workaround is to force the loop to be aligned ACROSS two longwords. Given this alignment, the processor correctly grants the internal bus to the debug module.

15.3.3 Programming Model

In addition to the existing BDM commands that provide access to the processor's registers

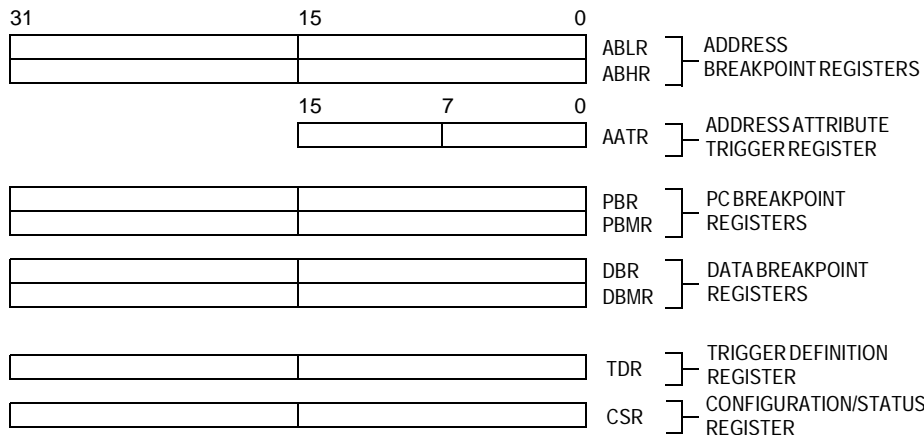

Figure 15-6. Debug Programming Model

and the memory subsystem, the debug module contains a number of registers to support the required functionality. All of these registers are treated as 32-bit quantities, regardless of the actual number of bits in the implementation. The registers, known as the Debug

Control Registers (DRc), are addressed using a 4-bit value as part of two new BDM commands (WDREG, RDREG).

These registers are also accessible from the processor's supervisor programming model through the execution of the WDEBUG instruction (Figure 15-5 illustrates the debug module programming model). Thus, the breakpoint hardware within the Debug module can be accessed by the external development system using the serial interface, or by the operating system running on the processor core. It is the responsibility of the software to guarantee that all accesses to these resources are serialized and logically consistent. The hardware provides a locking mechanism in the CSR to allow the external development system to disable any attempted writes by the processor to the Breakpoint Registers (setting IPW =1).

15.3.3.1 ADDRESS BREAKPOINT REGISTERS (ABLR, ABHR). The Address Breakpoint Registers define an upper (ABHR) and a lower (ABLR) boundary for a region in the operand logical address space of the processor that can be used as part of the trigger.

The ABAn thR vals ar c oaradit1-1.2ha (C)5.2(o)-0.8(l)5.2adeCedresv vii as

d78.7(e)21.3f(in)7.7(ds)10(by th)7.7(e)-10(settin)7.7gefeTDR(.)] TJ /F2 1 Tf 0 -2.16 TD -0.0089 Tc 0.0

R[7]—Read/Write

This field is compared with the R/W signal of the processor's local bus.

SZ[6:5]—Size

This field is compared to the size signals of the processor's local bus. These signals indicate the data size for the bus transfer.

- 00 = Longword
- 01 = Byte
- 10 = Word
- 11 = Reserved

TT[4:3]—Transfer Type

This field is compared with the transfer type signals of the processor's local bus. These signals indicate the transfer type for the bus transfer. These signals are always encoded as if the ColdFire is in the ColdFire IACK mode.

- 00 = Normal Processor Access
- 01 = Reserved
- 10 = Emulator Mode Access
- 11 = Acknowledge/CPU Space Access

These bits also define the TT encoding for BDM memory commands. In this case, the 01 encoding generates an alternate master access (For backward compatibility).

TM[2:0]—Transfer Modifier

This field is compared with the transfer modifier signals of the processor's local bus. These signals provide supplemental information for each transfer type. These signals are always encoded as if the processor is operating in the ColdFire IACK mode. The encoding for normal processor transfers (TT = 0) is:

- 000 = Explicit Cache Line Push
- 001 = User Data Access
- 010 = User Code Access
- 011 = Reserved
- 100 = Reserved
- 101 = Supervisor Data Access
- 110 = Supervisor Code Access
- 111 = Reserved

The encoding for emulator mode transfers (TT = 10) is:

- 0xx = Reserved
- 100 = Reserved
- 101 = Emulator Mode Data Access
- 110 = Emulator Mode Code Access
- 111 = Reserved

BITS	31														0
FIELD	MASK														
RESET	-														
R/W	W														

Data Breakpoint Mask Register (DBMR)

The data breakpoint register supports both aligned and misaligned operand references. The relationship between the processor core address, the access size, and the corresponding location within the 32-bit core data bus is shown in Table 15-12.

Table 15-10. Access Size and Operand Location

CORE ADDRESS[1:0]	ACCESS SIZE	OPERAND LOCATION
00	Byte	Data[31:24]
01	Byte	Data[23:16]
10	Byte	Data[15:8]
11	Byte	Data[7:0]
0x	Word	Data[31:16]
1x	Word	Data[15:0]
-x	Long	Data[31:0]

15.3.3.5 TRIGGER DEFINITION REGISTER (TDR). The TDR configures the operation of the hardware breakpoint logic within the Debug module and controls the actions taken under the defined conditions. The breakpoint logic can be configured as a one- or two-level trigger, where bits [29:16] of the TDR define the 2nd level trigger, bits [13:0] define the first level trigger, and bits [31:30] define the trigger response.

Reset clears the TDR.

31	30	29	28	27	26	25	24	23	22	21	20	19	18	17	16
TRC	EBL	EDLW	EDWL	EDWU	EDLL	EDLM	EDUM	EDUU	DI	EAI	EAR	EAL	EPC	PCI	
15	14	13	12	11	10	9	8	7	6	5	4	3	2	1	0
00	EBL	EDLW	EDWL	EDWU	EDLL	EDLM	EDUM	EDUU	DI	EAI	EAR	EAL	EPC	PCI	

TDR Bit Definitions

TRC—Trigger Response Control

The trigger response control determines how the processor is to respond to a completed

trigger condition. The trigger response is always displayed on the DDATA pins.

00=displayed on DDATA pins only
01=processor halt
10=debug interrupt
11=reserved

EBL—Enable Breakpoint Level

If set, this bit serves as the global enable for the breakpoint trigger. If cleared, all breakpoints are disabled.

EDLW—Enable Data Breakpoint for the Data Longword

If set, this bit enables the data breakpoint based on the core data bus (KD) KD[31:0] longword. The assertion of any of the ED bits enables the data breakpoint. If all bits are cleared, the data breakpoint is disabled.

EDWL—Enable Data Breakpoint for the Lower Data Word

If set, this bit enables the data breakpoint based on the KD[15:0] word.

EDWU—Enable Data Breakpoint for the Upper Data Word

If set, this bit enables the data breakpoint trigger based on the KD[31:16] word.

EDLL—Enable Data Breakpoint for the Lower Lower Data Byte

If set, this bit enables the data breakpoint trigger based on the KD[7:0] byte.

EDLM—Enable Data Breakpoint for the Lower Middle Data Byte

If set, this bit enables the data breakpoint trigger based on the KD[15:8] byte.

EDUM—Enable Data Breakpoint for the Upper Middle Data Byte

If set, this bit enables the data breakpoint trigger based on the KD[23:16] byte.

EDUU—Enable Data Breakpoint for the Upper Upper Data Byte

If set, this bit enables the data breakpoint trigger based on the KD[31:24] byte.

DI—Data Breakpoint Invert

This bit provides a mechanism to invert the logical sense of all the data breakpoint comparators. This can develop a trigger based on the occurrence of a data value *not equal* to the one programmed into the DBR.

The assertion of any of the EA bits enables the address breakpoint. If all three bits are cleared, this breakpoint is disabled.

EAI—Enable Address Breakpoint Inverted

If set, this bit enables the address breakpoint based *outside* the range defined by ABLR and ABHR.

EAR–Enable Address Breakpoint Range

If set, this bit enables the address breakpoint based on the *inclusive* range defined by ABLR and ABHR.

EAL–Enable Address Breakpoint Low

If set, this bit enables the address breakpoint based on the address contained in the ABLR.

EPC–Enable PC Breakpoint

If set, this bit enables the PC breakpoint. Clearing this bit disables the PC breakpoint.

PCI–PC Breakpoint Invert

If set, this bit allows execution *outside* a given region as defined by PBR and PBMR to enable a trigger. If cleared, the PC breakpoint is defined *within* the region defined by PBR and PBMR.

15.3.3.6 CONFIGURATION/STATUS REGISTER (CSR). The Configuration/Status Register defines the operating configuration for the processor and memory subsystem. In addition to defining the microprocessor configuration, this register also contains status information from the breakpoint logic. The CSR is cleared during system reset. The CSR can

31				28			27	26	25	24	23	17				16
STATUS				FOF	TRG	HALT	BKPT	RESERVED				IPW				
15	14	13	12	11	10	9	8	7	6	5	4	3	2	1	0	
MAP	TRC	EMU	DDC	UHE	BTB	0	NPL	IPI	SSM	0	0	0	0	0	0	

CSR Bit Definitions

be read and written by the external development system and written by the supervisor programming model.

Status–Breakpoint Status

This 4-bit field defines provides read-only status information concerning the hardware breakpoints. This field is defined as follows:

- \$0 = no breakpoints enabled
- \$1 = waiting for level 1 breakpoint
- \$2 = level 1 breakpoint triggered
- \$5 = waiting for level 2 breakpoint
- \$6 = level 2 breakpoint triggered

The CSR[30-28] bits are translated and output on the DDATA[3:1] signals where x is the

DDATA[0] bit.

- 000x = no breakpoints enabled
- 001x = waiting for level 1 breakpoint
- 010x = level 1 breakpoint triggered
- 101x = waiting for level 2 breakpoint
- 110x = level 2 breakpoint triggered

This breakpoint status is also output on the DDATA port when the bus is not displaying Cold-Fire CPU core captured data. A write to the TDR resets this field.

FOF–Fault-on-Fault

If this read-only status bit is set, a catastrophic halt has occurred and forced entry into BDM. This bit is cleared on a read of the CSR.

TRG–Hardware Breakpoint Trigger

If this read-only status bit is set, a hardware breakpoint has halted the processor core and forced entry into BDM. This bit is cleared on a read from the CSR or when the processor is restarted.

Halt–Processor Halt

If this read-only status bit is set, the processor has executed the HALT instruction and forced entry into BDM. This bit is cleared on a read from the CSR or when the processor is restarted.

BKPT–BKPT Assert

If this read-only status bit is set, the $\overline{\text{BKPT}}$ signal was asserted, forcing the processor into BDM. This bit is cleared on a read from the CSR or when the processor is restarted.

IPW–Inhibit Processor Writes to Debug Registers

If set, this bit inhibits any processor-initiated writes to the debug module's programming model registers. This bit can be modified only by commands from the external development system.

MAP–Force Processor References in Emulator Mode

If set, this bit forces the processor to map all references while in emulator mode to a special address space, TT = 10, TM = 101 (data) and 110 (text). If cleared, all emulator-mode references are mapped into supervisor text and data spaces.

TRC–Force Emulation Mode on Trace Exception

If set, this bit forces the processor to enter emulator mode when a trace exception occurs.

EMU–Force Emulation Mode

If set, this bit forces the processor to begin execution in emulator mode. This bit is examined only when $\overline{\text{RSTI}}$ is negated, as the processor begins reset exception processing.

DDC–Debug Data Control

This 2-bit field provides configuration control for capturing operand data for display on the DDATA port. The encoding is as follows:

- 00 = no operand data is displayed
- 01 = capture all internal write data
- 10 = capture all internal read data
- 11 = capture all internal read and write data

In all cases, the DDATA port displays the number of bytes defined by the operand reference size, i.e., byte displays 8 bits, word displays 16 bits, and long displays 32 bits.

UHE–User Halt Enable

This bit selects the CPU privilege level required to execute the HALT instruction.

- 0 = HALT is a privileged, supervisor-only instruction
- 1 = HALT is a nonprivileged, supervisor/user instruction

BTB–Branch Target Bytes

This 2-bit field defines the number of bytes of branch target address to be displayed on the DDATA outputs. The encoding is as follows:

- 00 = 0 bytes
- 01 = lower two bytes of the target address
- 10 = lower three bytes of the target address
- 11 = entire four-byte target address

The bytes are always displayed in a least-significant-to-most-significant order. The processor captures only those target addresses associated with taken branches using a variant addressing mode. This includes JMP and JSR instructions using address register indirect or indexed addressing modes, all RTE and RTS instructions as well as all exception vectors.

NPL–Nonpipelined Mode

If set, this bit forces the processor core to operate in a nonpipeline mode of operation. In this mode, the processor effectively executes a single instruction at a time with no overlap.

IPI–Ignore Pending Interrupts

If set, this bit forces the processor core to ignore any pending interrupt requests signalled on KIPL[2:0] while executing in single-instruction-step mode.

SSM–Single-Step Mode

If set, this bit forces the processor core to operate in a single-instruction-step mode. While in this mode, the processor executes a single instruction and then halts. While halted, any of the BDM commands can be executed. On receipt of the GO command, the processor executes the next instruction and then halts again. This process continues until the single-instruction-step mode is disabled.

Reserved

All bits labeled Reserved or “0” are currently unused and reserved for future use. These bits should always be written as 0.

15.4 MOTOROLA RECOMMENDED BDM PINOUT

The ColdFire BDM connector is a 26-pin Berg connector arranged 2x13, shown in Figure 15-6.

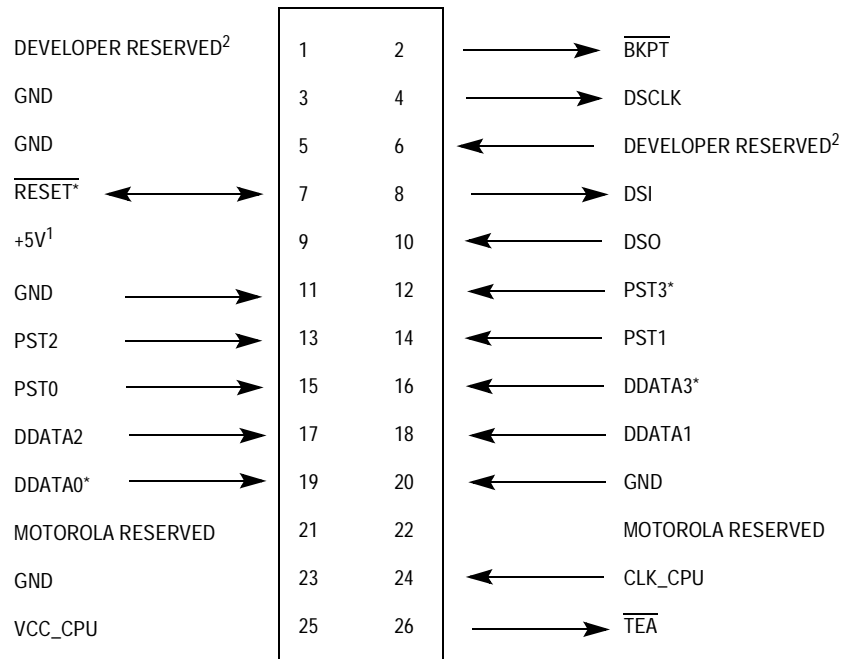

- NOTES:
 1. Supplied by target
 2. Pins reserved for BDM developer use. Contact developer.
 * Denotes a vectored signal

Figure 15-7. 26-Pin Berg Connector Arranged 2x13

15.4.1 Differences Between the ColdFire BDM and a CPU32 BDM

1. DSCLK, BKPT, and DSDI must meet the setup and hold times relative to the rising edge of the processor clock to prevent the processor from propagating metastable states.
2. DSO transitions relative to the rising edge of DSCLK only. In the CPU32 BDM, DSO transitions between serial transfers to indicate to the development system that a command has successfully completed. The ColdFire BDM does not support this feature.
3. The development system must note that the DSO is not valid during the first rising edge of DSCLK. Instead, the first rising edge of DSCLK causes DSO to transmit the MSB of DSO. A serial transfer is illustrated in Figure 15-8.



Figure 15-8. Serial Transfer Illustration

SECTION 16

IEEE 1149.1 TEST ACCESS PORT (JTAG)

The MCF5206e includes dedicated user-accessible test logic that is fully compliant with the IEEE standard 1149.1 *Standard Test Access Port and Boundary Scan Architecture*. Use the following description in conjunction with the supporting IEEE document listed above. This section includes the description of those chip-specific items that the IEEE standard requires as well as those items specific to the MCF5206e implementation.

The MCF5206e JTAG test architecture implementation currently supports circuit board test strategies that are based on the IEEE standard. This architecture provides access to all of the data and chip control pins from the board edge connector through the standard four-pin test access port (TAP) and the active-low JTAG reset pin, $\overline{\text{TRST}}$. The test logic itself uses a static design and is wholly independent of the system logic, except where the JTAG is subordinate to other complimentary test modes (see **Section 15: Debug Support** section for more information). When in subordinate mode, the JTAG test logic is placed in reset and the TAP pins can be used for other purposes in accordance with the rules and restrictions set forth using a JTAG compliance-enable pin.

The MCF5206e JTAG implementation can:

- Perform boundary-scan operations to test circuit board electrical continuity
- Bypass the MCF5206e device by reducing the shift register path to a single cell
- Sample the MCF5206e system pins during operation and transparently shift out the result
- Set the MCF5206e output drive pins to fixed logic values while reducing the shift register path to a single cell
- Protect the MCF5206e system output and input pins from backdriving and random toggling (such as during in-circuit testing) by placing all system signal pins to high-impedance state

NOTE

The IEEE Standard 1149.1 test logic cannot be considered completely benign to those planning not to use JTAG capability. You must observe certain precautions to ensure that this logic does not interfere with system or debug operation. Refer to Section 16.6 Disabling the IEEE 1149.1 Standard Operation.

16.1 OVERVIEW

Figure 16-1 is a block diagram of the MCF5206e implementation of the 1149.1 IEEE Standard. The test logic includes several test data registers, an instruction register, instruction register control decode, and a 16-state dedicated TAP controller.

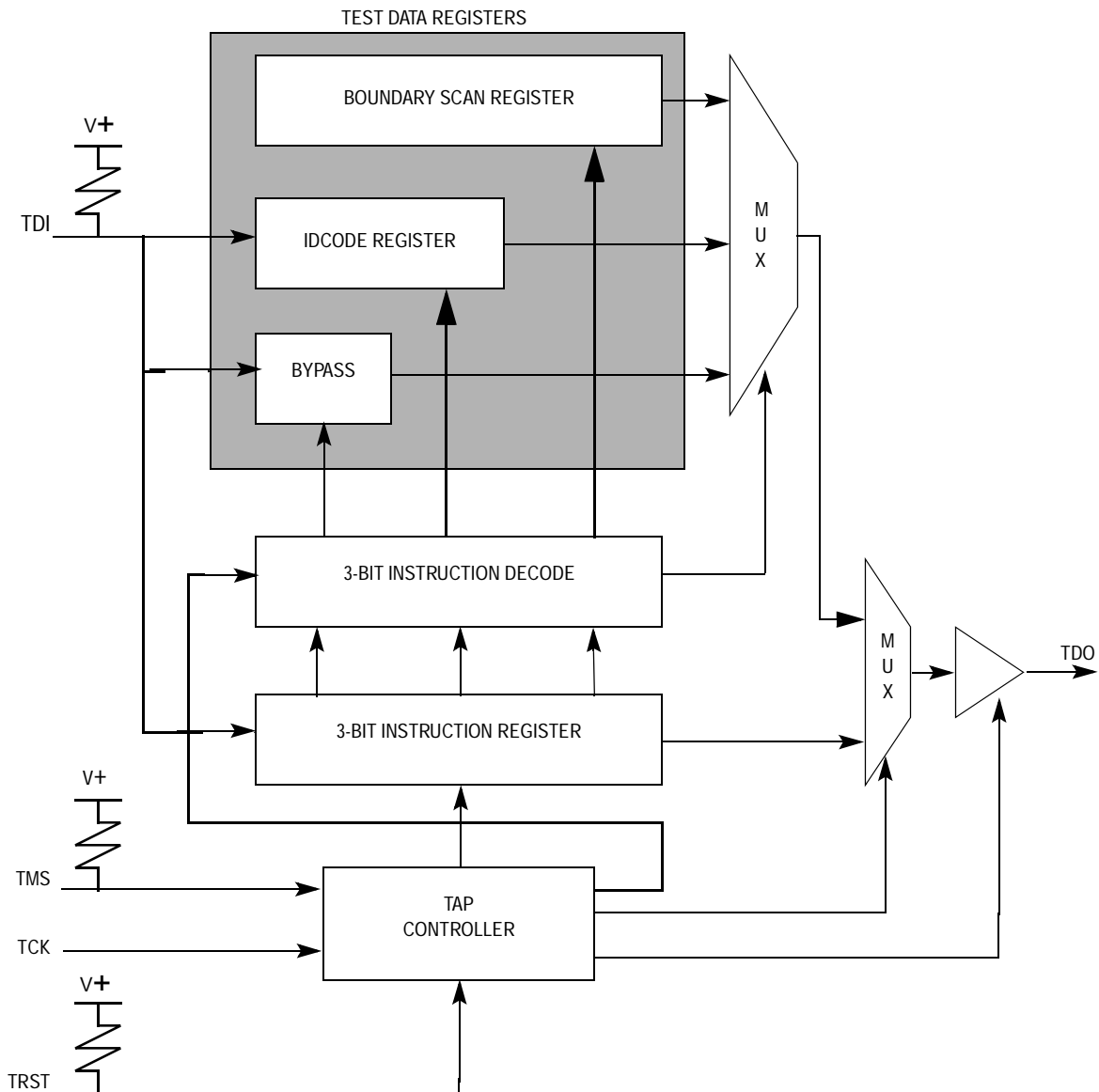

Figure 16-1. JTAG Test Logic Block Diagram

16.2 JTAG PIN DESCRIPTIONS

The MCF5206e JTAG pin is defined to be a compliance-enable input per Section 3.8 of the IEEE Standard 1149.1a-1993 entitled "Subordination of this Standard within a Higher Level Test Strategy." When JTAG is a logic 0, the MCF5206e is in JTAG mode; when JTAG is a logic 1, the MCF5206e is in Debug mode.

When the compliance-enable is set for JTAG mode, the pin descriptions in Table 16-1 apply.

Table 16-1. JTAG Pin Descriptions

PIN	DESCRIPTION
TCK	A test clock input that synchronizes test logic operations
TMS	A test mode select input with a default internal pullup resistor that is sampled on the rising edge of TCK to sequence the TAP controller
TDI	A serial test data input with a default internal pullup resistor that is sampled on the rising edge of TCK
TDO	A three-state test data output that is actively driven only in the Shift-IR and Shift-DR controller states and only updates on the falling edge of TCK
TRST	An active-low asynchronous reset with a default internal pullup resistor that forces the TAP controller into the test-logic-reset state.

16.3 JTAG REGISTER DESCRIPTIONS

16.3.1 JTAG Instruction Shift Register

The MCF5206e IEEE 1149.1 Standard implementation uses a 3-bit instruction-shift register without parity. This register transfers its value to a parallel hold register and applies one of six possible instructions on the falling edge of TCK when the TAP state machine is in the update-IR state. To load the instructions into the shift portion of the register, place the serial data on the TDI pin prior to each rising edge of TCK. The MSB of the instruction shift register is the bit closest to the TDI pin and the LSB is the bit closest to the TDO pin.

Table 16-2 lists the public customer-usable instructions that are supported along with their encoding.

Table 16-2. JTAG Instructions

INSTRUCTION	ABBR	CLASS	IR[2:0]	INSTRUCTION SUMMARY
EXTEST	EXT	Required	000	Select BS register while applying fixed values to output pins and asserting functional reset
IDCODE	IDC	Optional	001	Selects IDCODE register for shift
SAMPLE/ PRELOAD	SMP	Required	100	Selects BS register for shift, sample, and preload without disturbing functional operation
HIGHZ	HIZ	Optional	101	Selects the bypass register while three-stating all output pins and asserting functional reset
CLAMP	CMP	Optional	110	Selects bypass while applying fixed values to output pins and asserting functional reset
BYPASS	BYP	Required	111	Selects the bypass register for data operations

The IEEE 1149.1 Standard requires the EXTEST, SAMPLE/PRELOAD, and BYPASS instructions. IDCODE, CLAMP and HIGHZ are optional standard instructions that the MCF5206e implementation supports and are described in the 1149.1.

16.3.1.1 EXTEST INSTRUCTION. The external test instruction (EXTEST) selects the boundary-scan register. The EXTEST instruction forces all output pins and bidirectional pins configured as outputs to the preloaded fixed values (with the SAMPLE/PRELOAD instruction) and held in the boundary-scan update registers. The EXTEST instruction can

also configure the direction of bidirectional pins and establish high-impedance states on some pins. The EXTEST instruction becomes active on the falling edge of TCK in the update-IR state when the data held in the instruction-shift register is equivalent to octal 0.

16.3.1.2 IDCODE. The IDCODE instruction selects the 32-bit IDcode register for connection as a shift path between the TDI pin and the TDO pin. This instruction lets you interrogate the MCF5206e to determine its version number and other part identification data. The IDcode register has been implemented in accordance with IEEE 1149.1 so that the least significant bit of the shift register stage is set to logic 1 on the rising edge of TCK following entry into the capture-DR state. Therefore, the first bit to be shifted out after selecting the IDcode register is always a logic 1. The remaining 31-bits are also set to fixed values (see 16.3.2 IDCode Register) on the rising edge of TCK following entry into the capture-DR state.

The IDCODE instruction is the default value placed in the instruction register when a JTAG reset is accomplished by either asserting TRST or holding TMS high while clocking TCK through at least five rising edges and the falling edge after the fifth rising edge. A JTAG reset causes the TAP state machine to enter the test-logic-reset state (normal operation of the TAP state machine into the test-logic-reset state also results in placing the default value of octal 1 into the instruction register). The shift register portion of the instruction register is loaded with the default value of octal 1 when in the Capture-IR state and a rising edge of TCK occurs.

16.3.1.3 SAMPLE/PRELOAD INSTRUCTION. The SAMPLE/PRELOAD instruction provides two separate functions. First, it obtains a sample of the system data and control signals present at the MCF5206e input pins and just prior to the boundary scan cell at the output pins. This sampling occurs on the rising edge of TCK in the capture-DR state when an instruction encoding of octal 4 is resident in the instruction register. You can observe this sampled data by shifting it through the boundary-scan register to the output TDO by using the shift-DR state. Both the data capture and the shift operation are transparent to system operation. You are responsible for providing some form of external synchronization to achieve meaningful results because there is no internal synchronization between TCK and the system clock, CLK.

The second function of the SAMPLE/PRELOAD instruction is to initialize the boundary scan register update cells before selecting EXTEST or CLAMP. This is achieved by ignoring the data being shifted out of the TDO pin while shifting in initialization data. The update-DR state in conjunction with the falling edge of TCK can then transfer this data to the update cells. This data will be applied to the external output pins when one of the instructions listed above is applied.

16.3.1.4 HIGHZ INSTRUCTION. The HIGHZ instruction anticipates the need to backdrive the output pins and protect the input pins from random toggling during circuit board testing. The HIGHZ instruction selects the bypass register, forcing all output and bidirectional pins to the high-impedance state.

The HIGHZ instruction goes active on the falling edge of TCK in the update-IR state when the data held in the instruction shift register is equivalent to octal 5.

16.3.1.5 CLAMP INSTRUCTION. The CLAMP instruction selects the bypass register and asserts functional reset while simultaneously forcing all output pins and bidirectional pins configured as outputs to the fixed values that are preloaded and held in the boundary-scan update registers. This instruction enhances test efficiency by reducing the overall shift path to a single bit (the bypass register) while conducting an EXTEST type of instruction through the boundary-scan register. The CLAMP instruction becomes active on the falling edge of TCK in the update-IR state when the data held in the instruction-shift register is equivalent to octal 6.

16.3.1.6 BYPASS INSTRUCTION. The BYPASS instruction selects the single-bit bypass register, creating a single-bit shift register path from the TDI pin to the bypass register to the TDO pin. This instruction enhances test efficiency by reducing the overall shift path when a device other than the MCF5206e processor becomes the device under test on a board design with multiple chips on the overall 1149.1 defined boundary-scan chain. The bypass register has been implemented in accordance with 1149.1 so that the shift register stage is set to logic zero on the rising edge of TCK following entry into the capture-DR state. Therefore, the first bit to be shifted out after selecting the bypass register is always a logic zero (to differentiate a part that supports an IDCODE register from a part that supports only the bypass register). The BYPASS instruction goes active on the falling edge of TCK in the update-IR state when the data held in the instruction shift register is equivalent to octal 7.

16.3.2 IDcode Register

An IEEE 1149.1 compliant JTAG identification register has been included on the MCF5206e. The MCF5206e JTAG instruction encoded as octal 1 provides for reading the JTAG IDcode register. The format of this register is defined below.

ID code Register

31	30	29	28	27	26	25	24	23	22	21	20	19	18	17	16
VERSION NO				0	1	0	0	1	1	0	0	0	0	0	0
15	14	13	12	11	10	9	8	7	6	5	4	3	2	1	0
0	0	0	1	0	0	0	0	0	0	0	0	1	0	1	1

Bits 31-28 Version Number

Indicates the revision number of the MCF5206e.

Bits 27-22 Design Center

Indicates the ColdFire design center.

Bits 21-12 Device Number

Indicates an MCF5206e.

Bits 11-1 JEDEC ID

Indicates the reduced JEDEC ID for Motorola (JEDEC refers to the Joint Electron Device Engineering Council. Refer to JEDEC publication 106-A and chapter 11 of the IEEE 1149.1 Standard for further information on this field).

Bit 0

Differentiates this register as the JTAG IDcode register (as opposed to the bypass register) according to the IEEE 1149.1 Standard.

16.3.3 JTAG BOUNDARY-SCAN REGISTER

The MCF5206e model includes an IEEE 1149.1-compliant boundary-scan register. The boundary-scan register is connected between TDI and TDO when the EXTEST or SAMPLE/PRELOAD instructions are selected. This register captures signal pin data on the input pins, forces fixed values on the output signal pins, and selects the direction and drive characteristics (a logic value or high impedance) of the bidirectional and three-state signal pins.

Boundary scan bit definitions

The latest (and most accurate) version of the boundary scan bit definitions can be downloaded from the ColdFire homepage on the Motorola website -

<http://www.motorola.com/ColdFire>

Please select the ColdFire processor of your choice and search under the product documentation hypertext button.

16.3.4 JTAG BYPASS REGISTER

The MCF5206e includes an IEEE 1149.1-compliant bypass register, which creates a single bit shift register path from TDI to the bypass register to TDO when the BYPASS instruction is selected.

16.4 TAP CONTROLLER

The value of TMS at the rising edge of TCK determines the current state of the TAP controller. There are basically two paths that the TAP controller can follow: The first, for executing JTAG instructions; the second, for manipulating JTAG data based on the JTAG instructions. The various states of the TAP controller are shown in Figure 16-2. For more detail on each state, refer to the IEEE 1149.1 Standard JTAG document. Do note, though, that from any state the TAP controller is in, Test-Logic-Reset can be entered if TMS is held high for at least five rising edges of TCK.

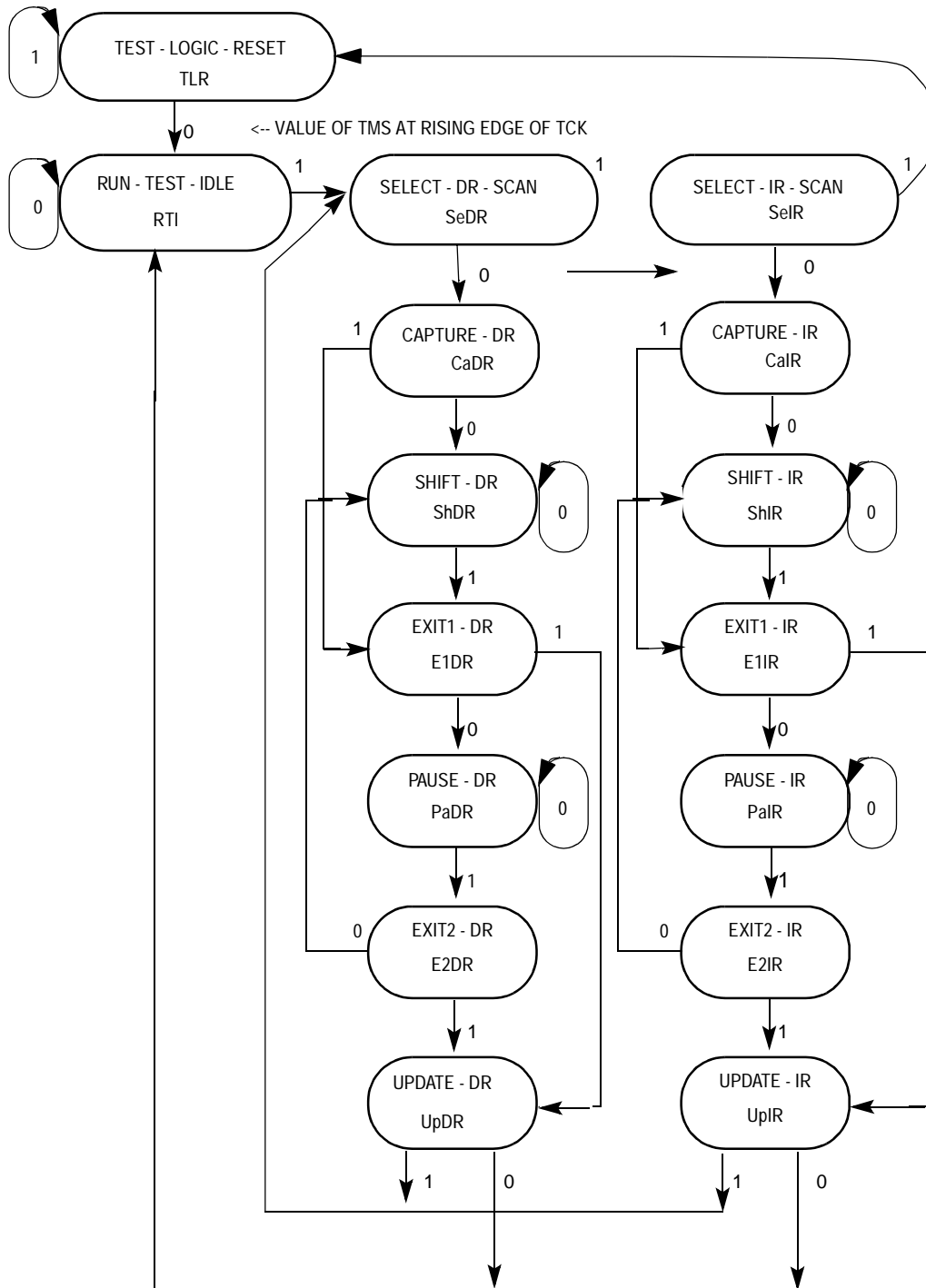

Figure 16-2. JTAG TAP Controller State Machine

16.5 RESTRICTIONS

The test logic is implemented using static logic design, and TCK can be stopped in either a high or low state without loss of data. The system logic, however, operates on a different

system clock which is not synchronized to TCK internally. Any mixed operation requiring the use of 1149.1 test logic in conjunction with system functional logic that uses both clocks must have coordination and synchronization of these clocks done externally to the MCF5206e.

16.6 DISABLING THE IEEE 1149.1 STANDARD OPERATION

There are two methods by which the MCF5206e can be used without the IEEE 1149.1 test logic being active: 1) Nonuse of the JTAG test logic by either nontermination (disconnection) or intentional fixing of TAP logic values, and 2) Intentional disabling of the JTAG test logic by assertion of the JTAG signal (entering Debug mode).

There are several considerations that must be addressed if the IEEE 1149.1 logic is not going to be used once the MCF5206e is assembled onto a board. The prime consideration is to ensure that the IEEE 1149.1 test logic remains transparent and benign to the system logic during functional operation. This requires the minimum of either connecting the TRST pin to logic 0, or connecting the TCK clock pin to a clock source that will supply five rising edges and the falling edge after the fifth rising edge, to ensure that the part enters the test-logic-reset state. The recommended solution is to connect TRST to logic 0. Another consideration is that the TCK pin does not have an internal pullup as is required on the TMS, TDI, and TRST pins; therefore, it should not be left unterminated to preclude mid-level input values. Figure 16-3 shows pin values recommended for disabling JTAG with the MCF5206e in JTAG mode (JTAG=0).

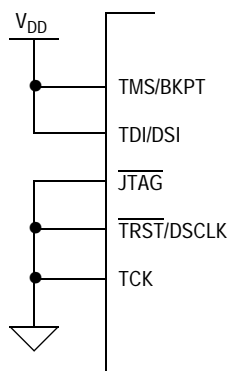

Figure 16-3. Disabling JTAG in JTAG Mode

A second method of using the MCF5206e without the IEEE 1149.1 logic being active is to select debug mode by placing a logic 1 on the defined compliance enable pin, JTAG. When JTAG is a logic 1, then the IEEE 1149.1 test controller is placed in the test-logic-reset state by the internal assertion of the TRST signal to the controller, and, the TAP pins function as Debug mode pins. While in JTAG mode, input pins TDI/DSI, TMS/BKPT, and

$\overline{\text{TRST}}/\text{DSCLK}$ have internal pullups enabled. Figure 16-4 shows pin values recommended for disabling JTAG with the MCF5206e in Debug mode.

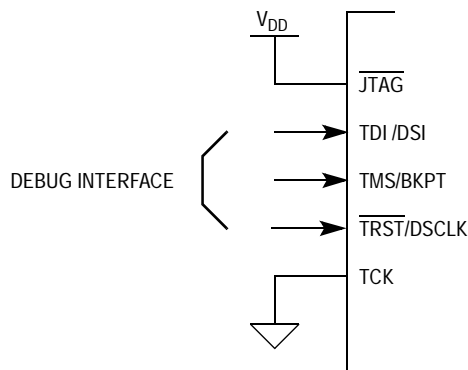

Figure 16-4. Disabling JTAG in Debug Mode

16.7 MOTOROLA MCF5206E BSDL DESCRIPTION

The MCF5206e BSDL description is available on the World Wide Web at <http://www.mot.com/coldfire>

16.8 OBTAINING THE IEEE 1149.1 STANDARD

The IEEE 1149 Standard JTAG specification is available directly from IEEE:

IEEE Standards Department
 445 Hoes Lane
 P.O. Box 1331
 Piscataway, NJ 08855-1331
 USA

<http://stdsbbs.ieee.org/>

Fax: 908-981-9667
 Information: 908-981-0060 or 1-800-678-4333

SECTION 17 ELECTRICAL CHARACTERISTICS

17.1 MAXIMUM RATINGS

17.1.1 Supply, Input Voltage and Storage Temperature

Table 17-1. Supply, Input Voltage and Storage Temperature

RATING	SYMBOL	VALUE	UNIT
Supply voltage	V_{DD}	-0.3 to + 4.0	V
Maximum Operating Voltage	V_{DD}	+3.6	V
Minimum Operating Voltage	V_{DD}	+3.0	V
Input voltage	V_{in}	-0.5 to +5.5	V
Storage temperature range	T_{stg}	-55 to 150	°C

The ratings in the above table define maximum conditions under which the MCF5206e device may be subjected without being damaged. However, the device cannot operate normally while being exposed to these electrical extremes.

This device contains circuitry that protects against damage from high static voltages or electrical fields; however, you should take normal precautions to avoid application of any voltages higher than maximum-rated voltages to this high-impedance circuit. Operational reliability improves when unused inputs are tied to an appropriate logic voltage level (e.g., either GND or V_{DD}).

17.1.2 Operating Temperature

Table 17-2. Operating Temperature

CHARACTERISTIC	SYMBOL	VALUE	UNIT
Maximum operating junction temperature	T_J	TBD	$^{\circ}\text{C}$
Maximum operating ambient temperature	T_{Amax}	70 ^a	$^{\circ}\text{C}$
Maximum operating ambient temperature (Extended Temperature device)	T_{Amax}	85 ^a	$^{\circ}\text{C}$
Minimum operating ambient temperature	T_{Amin}	0	$^{\circ}\text{C}$
Minimum operating ambient temperature (Extended Temperature device)	T_{Amin}	-40	$^{\circ}\text{C}$

^a This published maximum operating ambient temperature should be used only as a system design guideline. All device operating parameters are guaranteed only when the junction temperature lies within the specified range.

NOTE

At printing, power dissipation figures were not available. Refer to the World Wide Web site at <http://www.motorola.com/ColdFire> for the latest accurate power dissipation information for the MCF5206e processor.

17.1.3 Thermal Resistance

Table 17-3. Thermal Resistance

CHARACTERISTIC		VALUE	RATING
Thermal resistance, junction to ambient	q_{ja}	38 ¹	$^{\circ}\text{C/W}$
Thermal resistance, junction to top reference	Y_{jt}	3	$^{\circ}\text{C/W}$

¹ q_{ja} and Y_{jt} parameters are simulated in accordance with EIA/JESD Standard 51-2 for natural convection. Motorola recommends the use of q_{ja} and power dissipation specifications in the system design to prevent device junction temperatures from exceeding the rated specification. System designers should be aware that device junction temperatures can be significantly influenced by the board layout and surrounding devices. Conformance to the device junction temperature specification can be verified by physical measurement in the customer's system using the Y_{jt} parameter, the device power dissipation, and the method described in EIA/JESD Standard 51-2.

17.1.4 Output Loading

Table 17-4. Output Loading

CHARACTERISTIC	SYMBOL	MAXIMUM	UNIT
Load Capacitance (All outputs)	C_L	50	pF

17.2 DC ELECTRICAL SPECIFICATIONS

Table 17-5. DC ELECTRICAL SPECIFICATIONS

CHARACTERISTIC	SYMBOL	MIN	MAX	UNIT
Operation voltage range	V_{DD}	3.0	3.6	V
Input high voltage	V_{IH}	2	55	V
Input low voltage	V_{IL}	GND	0.8	V
Input signal undershoot	—	—	0.8	V
Input signal overshoot	—	—	0.8	V
Input leakage current @ GND, V_{DD} CLK, A[27:0], D[31:0], TS, SZ[1:0], RW, TA, ATA, TEA, IPL[2]/IRQ[7], IPL[1]/IRQ[4], IPL[0]/IRQ[1], BG, RD[2:1], CTS[2:1], TIN[1:0], PP[7:0], PST[3:0], DDATA[3:0], RSTI, TCK, HIZ, JTAG	I_{in}	—	20	uA
HI-Z (three-state) leakage current @ GND, V_{DD} A[27:0], D[31:0], TS, TT[1:0], ATM, SZ[1:0], RW, TA, TDODSO	I_{TSI}	—	20	uA
Signal Low Input Current, $V_{IL}=0.8V$ TMS/BKPT, TD/DSI, TRST/DSCLK	I_{L}	TBD	TBD	mA
Signal High Input Current, $V_{IH}=2.0V$ TMS/BKPT, TD/DSI, TRST/DSCLK	I_{H}	TBD	TBD	mA
Output high voltage, $I_{OH}=8mA$ (All signals except RAS[1:0], CAS[3:0], DRAMW), $I_{OH}=16mA$ (RAS[1:0], CAS[3:0], DRAMW)	V_{OH}	2.4	—	V
Output low voltage, $I_{OL}=8mA$ (All signals except RAS[1:0], CAS[3:0], DRAMW), $I_{OL}=16mA$ (RAS[1:0], CAS[3:0], DRAMW)	V_{OL}	—	0.5	V
Pin capacitance*	C_{in}	—	10	pF

* This specification periodically sampled but not 100% tested.

17.3 AC ELECTRICAL SPECIFICATIONS

17.3.1 Clock Input Timing Specifications

Table 17-6. Clock Input Timing Specifications

NAME	CHARACTERISTIC	40 MHz		54 MHz		UNIT
		MIN	MAX	MIN	MAX	
	Frequency of Operation ¹	0	40.00	0	54.00	MHz
C1	CLK cycle time	25	—	18.5	—	ns
C2 ²	CLK fall time (from $V_h = 2.4V$ to $V_l = 0.5V$)	—	2	—	2	ns
C3 ²	CLK rise time (from $V_l = 0.5V$ to $V_h = 2.4V$)	—	2	—	2	ns
C4	CLK duty cycle (measured at 1.5 V)	45	55	45	55	%
C4a ³	CLK pulse width high (measured at 1.5 V)	11.25	13.75	8.33	10.19	ns
C4b ³	CLK pulse width low (measured at 1.5 V)	11.25	13.75	8.33	10.19	ns

¹ CLK may be stopped to conserve power.

² Specification values are not tested.

³ Specification values listed are for maximum frequency of operation.

17.3.2 Clock Input Timing Diagram

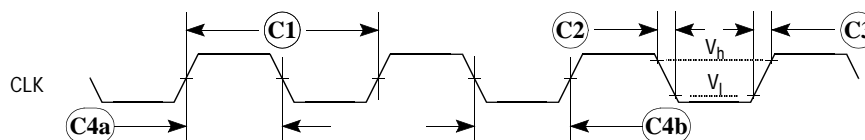

Figure 17-1. Clock Input Timing

17.3.3 Processor Bus Input Timing Specifications

Table 17-7. Processor Bus Input Timing Specifications

NAME	CHARACTERISTIC	40 MHz		54 MHz		UNIT
		MIN	MAX	MIN	MAX	
CONTROL INPUTS						
B1a	TS Valid to CLK (Setup)	5	—	3.5	—	ns
B1b	TA, Valid to CLK (Setup)	5	—	4.2	—	ns
B1c	ATA Valid to CLK (Setup)	1.5	—	1	—	ns
B1d	TEA Valid to CLK (Setup)	4.5	—	4.2	—	ns
B1e	BG Valid to CLK (Setup)	5.5	—	5	—	ns
B1f	IPL[2:0]/IRQ[7,4,1] Valid to CLK (Setup)	1.5	—	1	—	ns
B1g	RSTI Valid to CLK (Setup)	1.5	—	1	—	ns
B1h	DSCLK to CLK (Setup)	4	—	3	—	ns
B1i	DSI Valid to CLK (Setup)	6	—	4.2	—	ns
B1j	BKPT to CLK	6	—	4.2	—	ns
B2a	CLK to Synchronous Control Input (TS, TA, TEA, BG, DSI, DSCLK) Invalid (Hold)	4.5	—	4.5	—	ns
B2b	CLK to Asynchronous Control Input (ATA, IPL[2:0]/IRQ[7,4,1], RSTI, BKPT) Invalid (Hold)	4.5	—	4.5	—	ns
B2c	CLK to Mode Selects Invalid (RSTI Asserted)	4.5	—	4.5	—	ns
ADDRESS AND ATTRIBUTE INPUTS						
B3a	Address Input (A[27:0]) Valid to CLK (Setup)	3	—	2	—	ns
B3b	Attribute Input (SIZ[1:0], R/W) Valid to CLK (Setup)	5	—	3.5	—	ns
B4a	CLK to Address Input (A[27:0]) Invalid (Hold)	4.5	—	4.5	—	ns
B4b	CLK to Address and Attribute Input (SIZ[1:0], R/W) Invalid (Hold)	4.5	—	4.5	—	ns
DATA INPUTS						
B5	Data Input (D[31:0]) Valid to CLK (Setup)	6	—	3	—	ns
B6	CLK to Data Input (D[31:0]) Invalid (Hold)	4.5	—	4.5	—	ns

17.3.4 Input Timing Waveform Diagram

* The same timings are valid for negative edge inputs

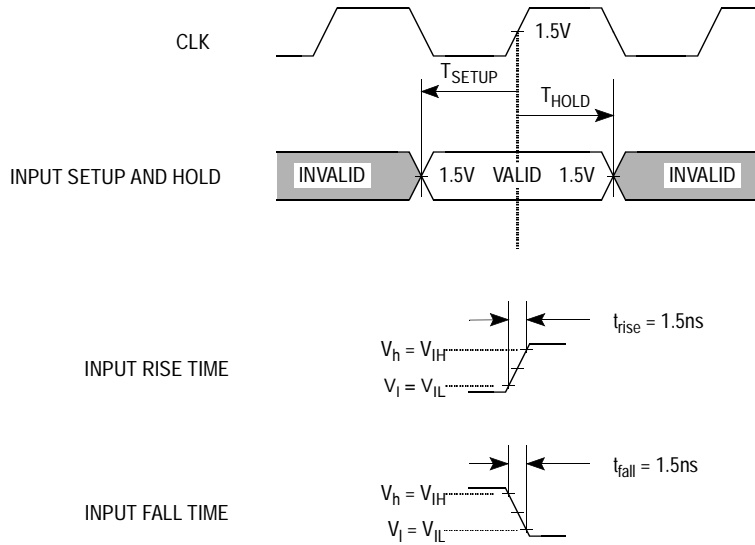

Figure 17-2. Input Timing Waveform Requirements

17.3.5 Processor Bus Output Timing Specifications

Table 17-8. Processor Bus Output Timing Specifications

NAME	CHARACTERISTIC*	40 MHz		54 MHz		UNIT
		MIN	MAX	MIN	MAX	
CONTROL OUTPUTS						
B7a	CLK to TS Valid (signal from driven or three-state)	3	20	3	15	ns
B7b	CLK to TA Valid (signal from driven or three-state)	3	19	3	14	ns
B7c	CLK (falling) to RAS[1:0] Valid	3	16.5	3	14	ns
B7d	CLK (falling) to CAS[3:0] Valid	3	16.5	3	14	ns
B7e	CLK to DRAMW Valid	3	19	3	14	ns
B7f	CLK to BR, BD Valid	3	21	3	15.5	ns
B7g	CLK to RSTO Valid	3	18.5	3	15.5	ns
B7h	CLK to PST[3:0], DDATA[3:0], DSO Valid	3	19.5	3	17	ns
B8a	CLK to Control Output (\overline{TS} , \overline{TA} , \overline{BR} , \overline{BD} , RAS[1:0], DRAMW, PST[3:0], DDATA[3:0], DSO, RSTO) Invalid (Output Hold)	3	-	3	-	ns
B8b	CLK (rising or falling) to \overline{CAS} [3:0] Invalid (Output Hold)	3	-	3	-	ns
B9	CLK to Control Output (TS, TA) High Impedance	-	22.5	-	17	ns
ADDRESS AND ATTRIBUTE OUTPUTS						
B10a	CLK to Address or Attribute Output (A[27:0], TT[1:0], ATM, CS[7:4], WE[3:0]) Valid (signal from driven or three-state)	3	19	3	16	ns
B10b	CLK to SIZ[1:0] Valid (signal from driven or three-state)	3	19.5	3	16.5	ns
B10c	CLK to R/W Valid (signal from driven or three-state)	3	18.5	3	15.5	ns
B10d	CLK to Attribute Output (CS[3:0]) Valid (signal from driven or three-state)	3	20.5	3	17.5	ns
B11	CLK to Address or Attribute Output (A[27:0], TT[1:0], ATM, SIZ[1:0], R/W, CS[7:0], WE[3:0]) Invalid (Output Hold)	3	-	3	-	ns
B12a	CLK to Address or Attribute Output (A[27:0], TT[1:0], ATM, CS[7:4], WE[3:0]) High Impedance	-	19.5	-	16.5	ns
B12b	CLK to SIZ[1:0] High Impedance	-	20	-	17	ns
B12c	CLK to R/W High Impedance	-	20	-	17	ns
B12d	CLK to Attribute Output (CS[3:0]) High Impedance	-	18.5	-	15.5	ns
DATA OUTPUTS						
B13	CLK to Data Output (D[31:0]) Valid (signal from driven or three-state)	3	21	3	17	ns
B14	CLK to Data Output (D[31:0]) Invalid (Output Hold)	3	-	3	-	ns
B15	CLK to Data Output (D[31:0]) High Impedance	-	20	-	15	ns
OTHER OUTPUTS						
B16	HIZ to output tristated (HIZ asserted)	3	20	3	15	ns
B17	HIZ to output driven valid (HIZ negated)	3	48	3	36	ns

* Output timing is measured at the pin. Output specifications assume a capacitive load of 50pF.

Freescale Semiconductor, Inc.

17.3.6 Output Timing Waveform Diagram

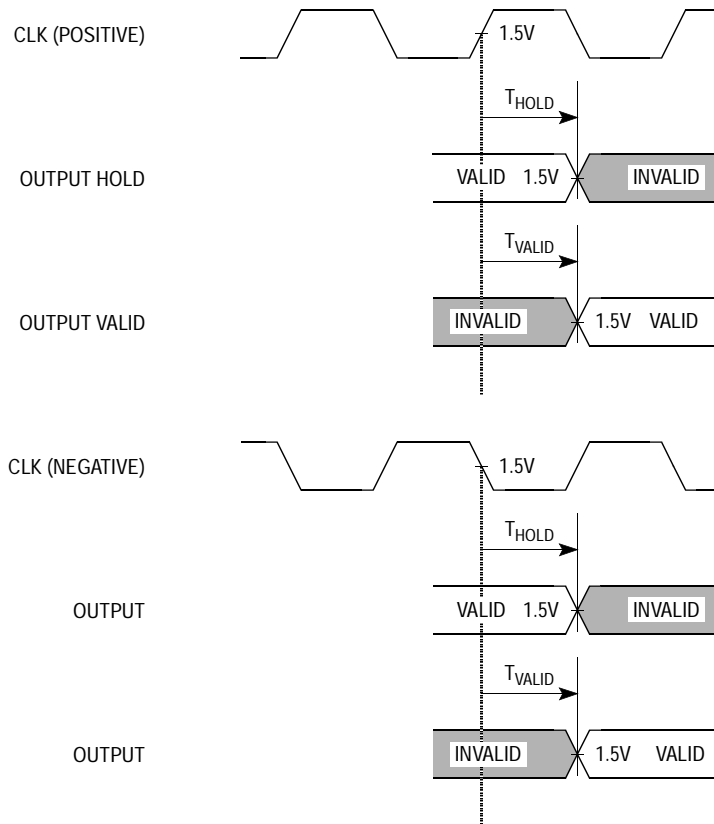
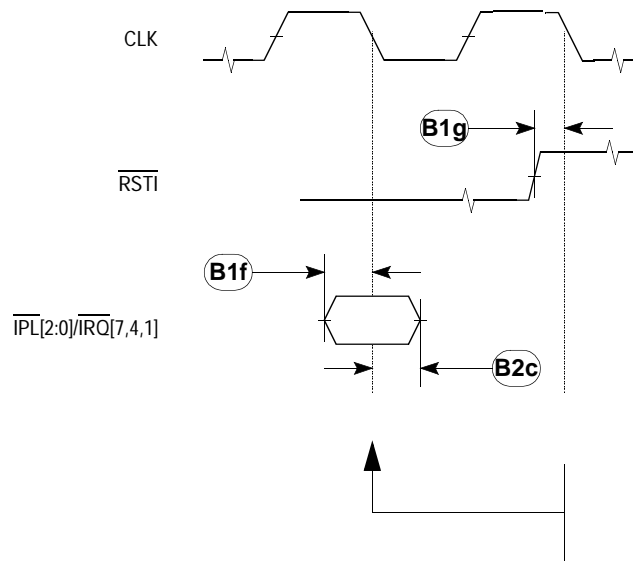

Figure 17-3. Output Timing Waveform

17.3.7 Processor Bus Timing Diagrams



MODE SELECTS ARE REGISTERED ON THE PREVIOUS FALLING CLK EDGE BEFORE THE CYCLE IN WHICH $\overline{\text{RSTI}}$ IS RECOGNIZED AS BEING NEGATED.

Figure 17-4. Reset Configuration Timing

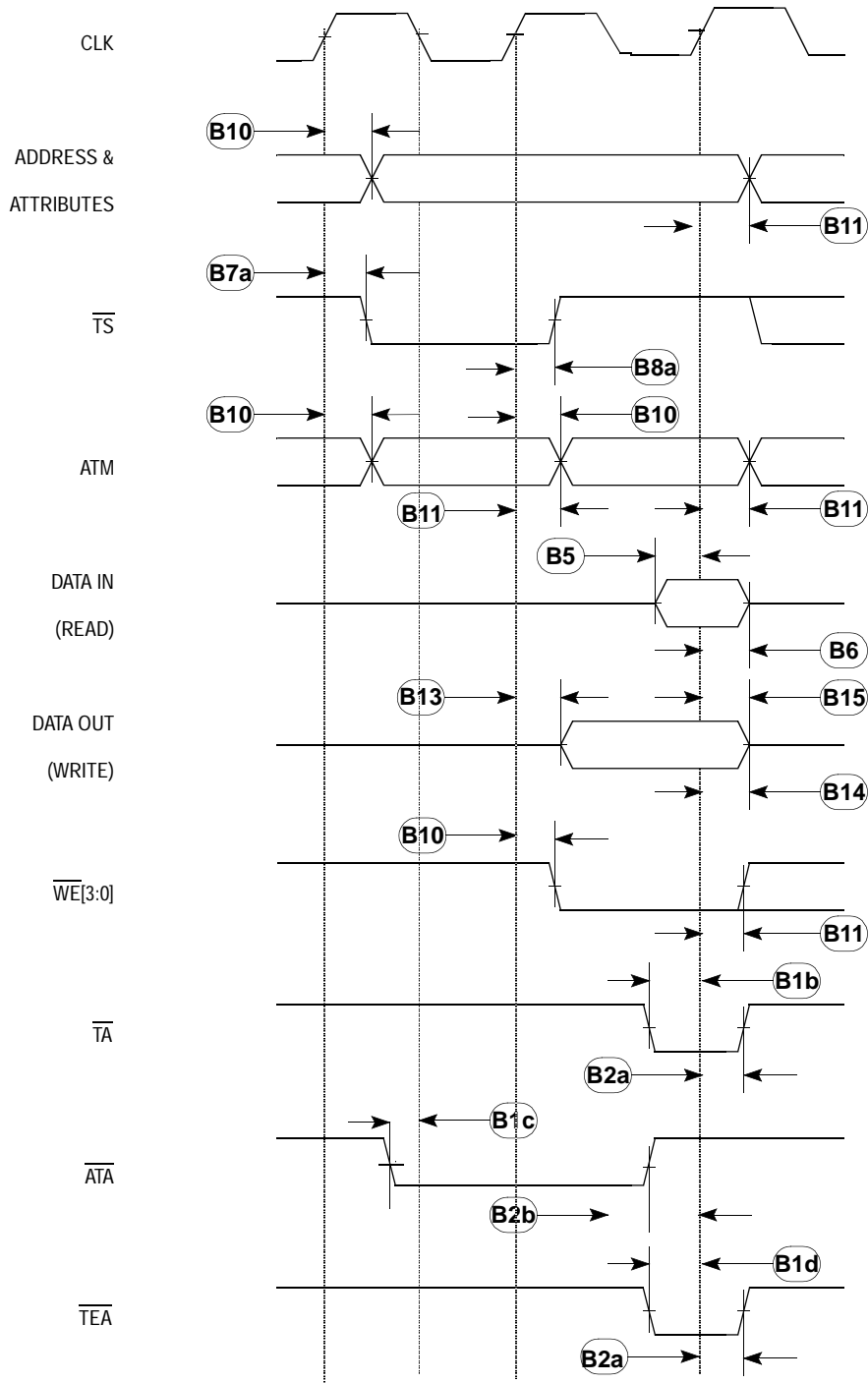

NOTE: ADDRESS AND ATTRIBUTES REFER TO THE FOLLOWING SIGNALS:
A[27:0], SIZ[1:0], R/W, TT[1:0], ATM, AND CS[7:0].

Figure 17-5. Read and Write Timing

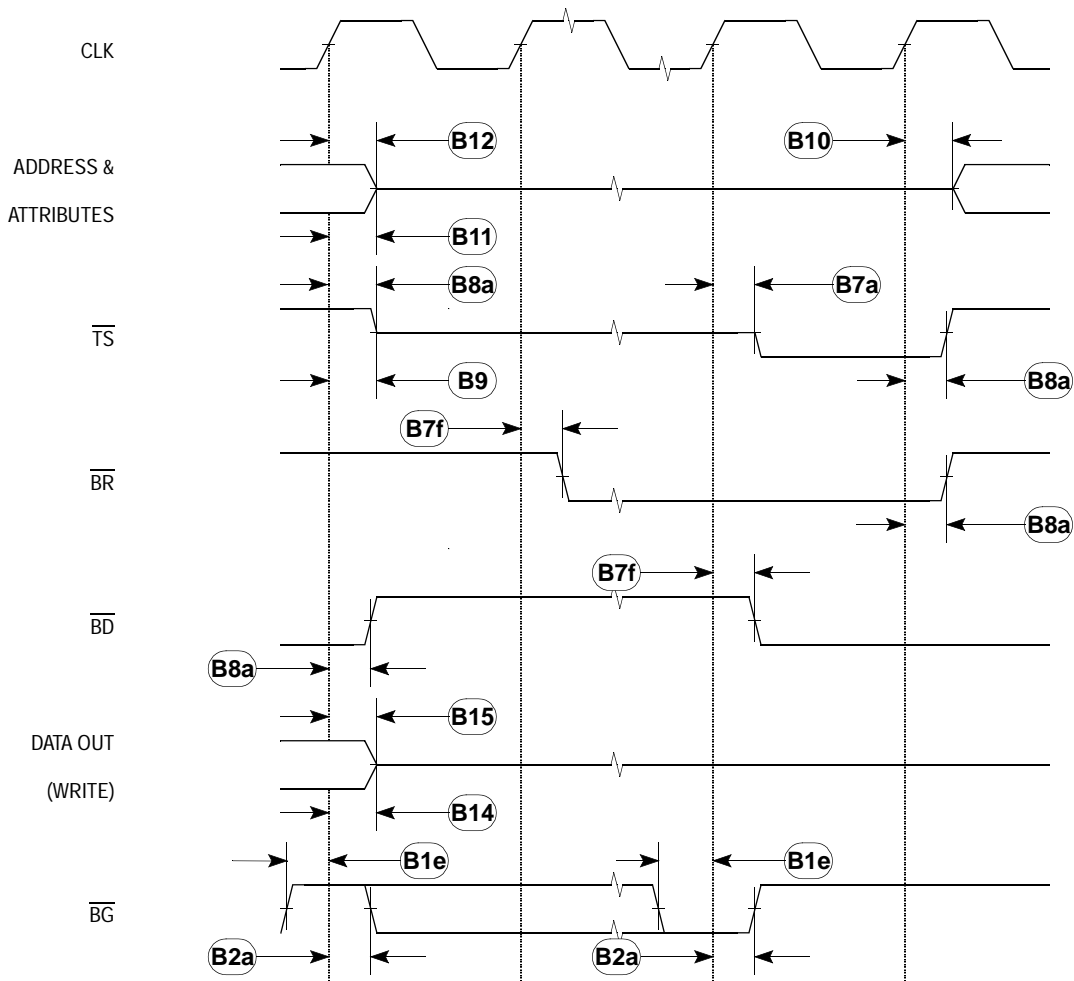

NOTE: ADDRESS AND ATTRIBUTES REFER TO THE FOLLOWING SIGNALS:
A[27:0], SIZ[1:0], R/W, TT[1:0], ATM, CS[7:0] AND WE[3:0].

Figure 17-6. Bus Arbitration Timing

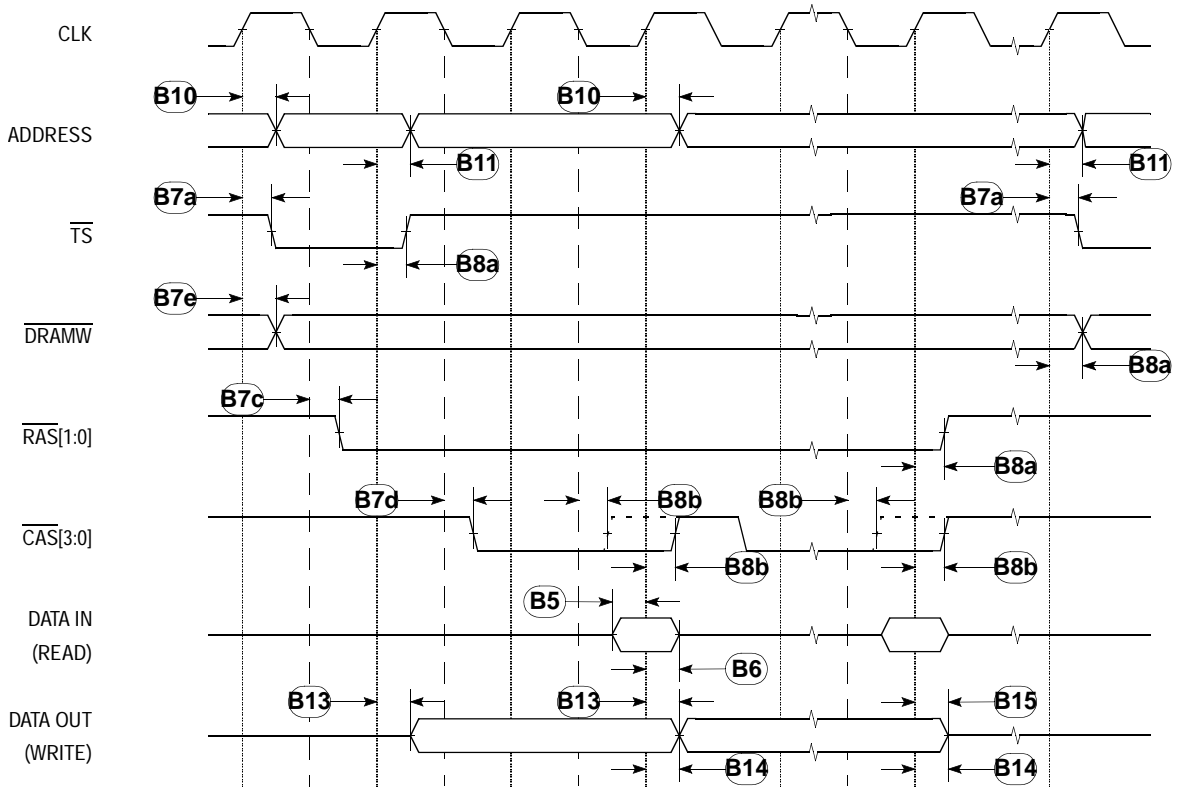

Figure 17-7. DRAM Signal Timing

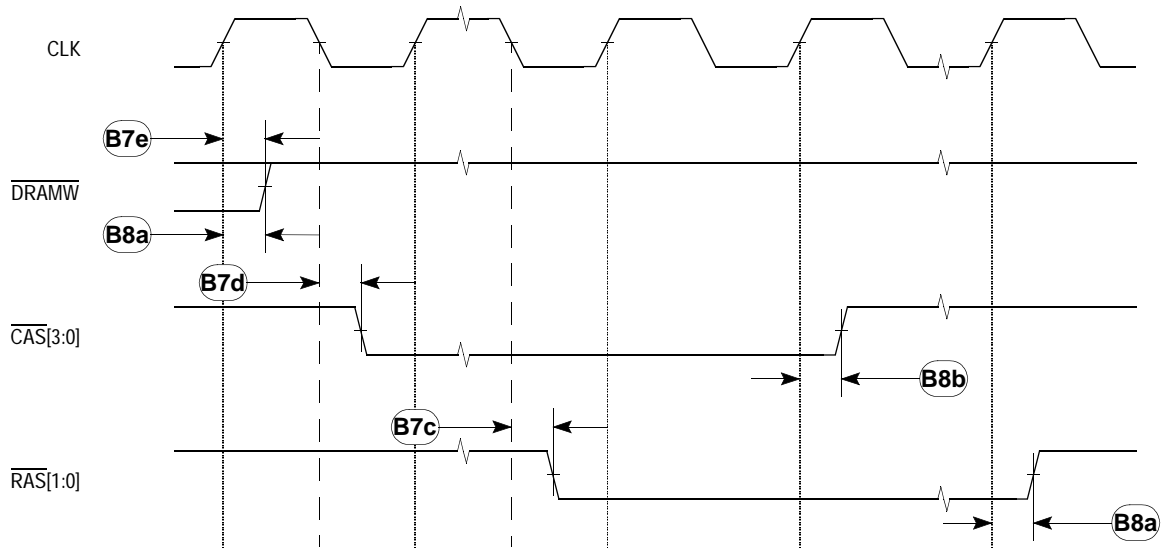

Figure 17-8. DRAM Refresh Cycle Timing

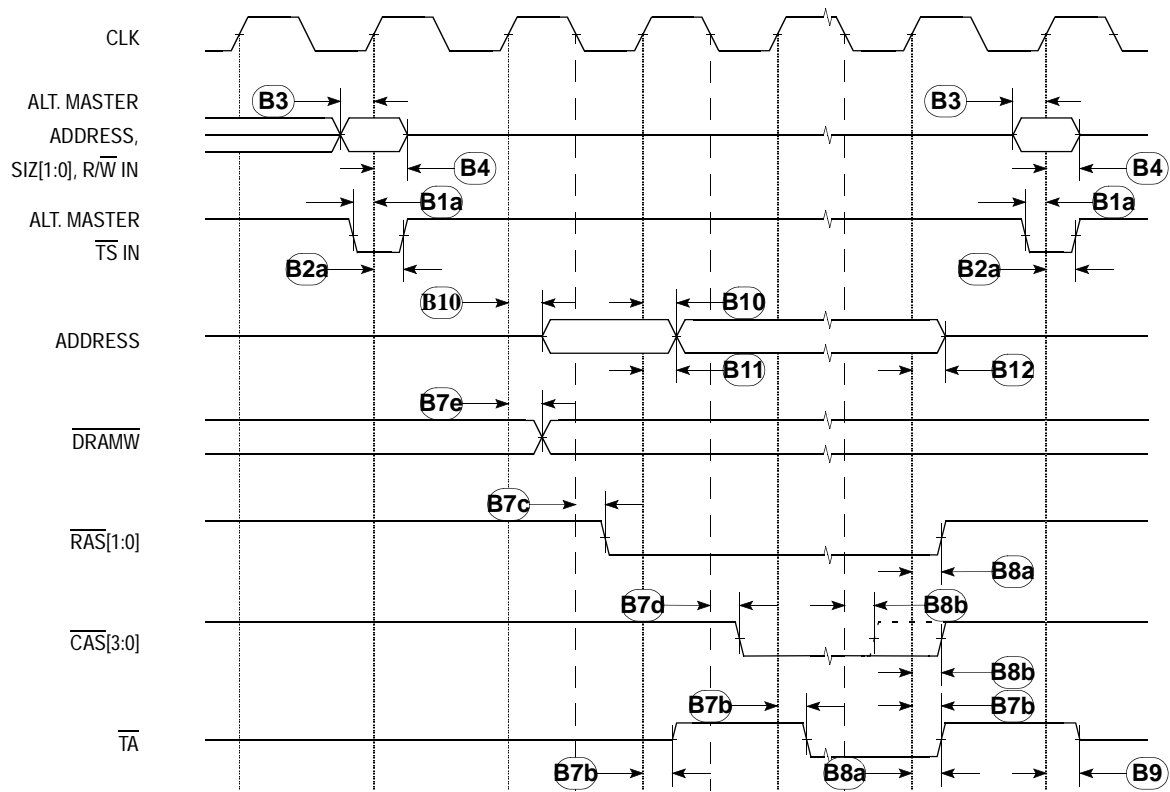

Figure 17-9. DRAM Control By External Master Timing

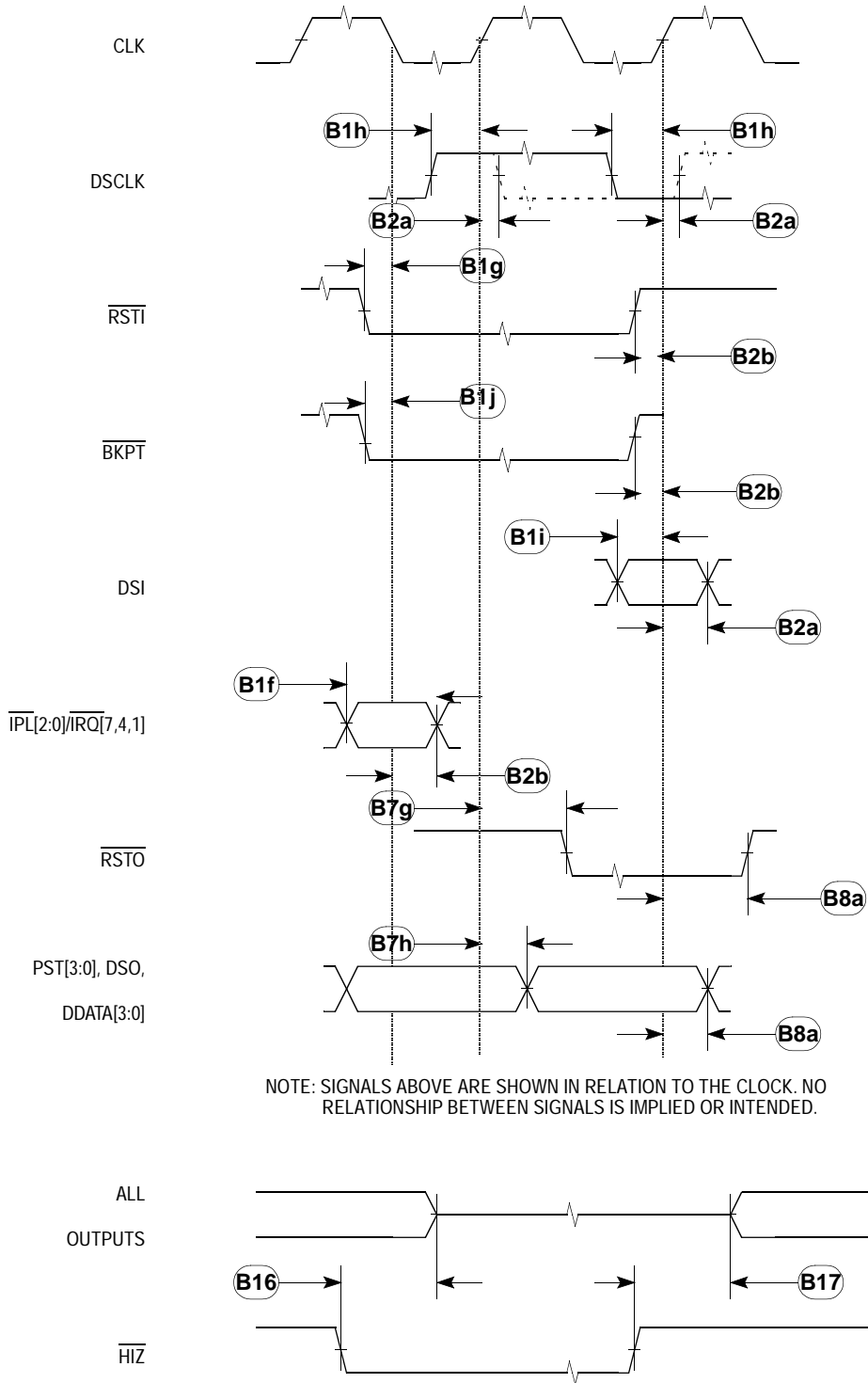

Figure 17-10. Miscellaneous Signal Timing

17.3.8 Timer Module AC Timing Specifications

Table 17-9. Timer Module AC Timing Specifications

NAME	CHARACTERISTIC	40 MHz		54 MHz		UNIT
		MIN	MAX	MIN	MAX	
T1	TIN[1:0] cycle time	3	—	3	—	clk
T2	TIN[1:0] Valid to CLK (Setup)	4	—	2.5	—	ns
T3	CLK to TIN[1:0] Invalid (Hold)	4.5	—	4.5	—	ns
T4	CLK to TOUT[1:0] Valid	3	22	3	16.5	ns
T5	CLK to TOUT[1:0] Invalid (Output Hold)	3	—	3	—	ns
T6	TIN[1:0] pulse width	1	—	1	—	clk
T7	TOUT[1:0] pulse width	1	—	1	—	clk

17.3.9 Timer Module Timing Diagram

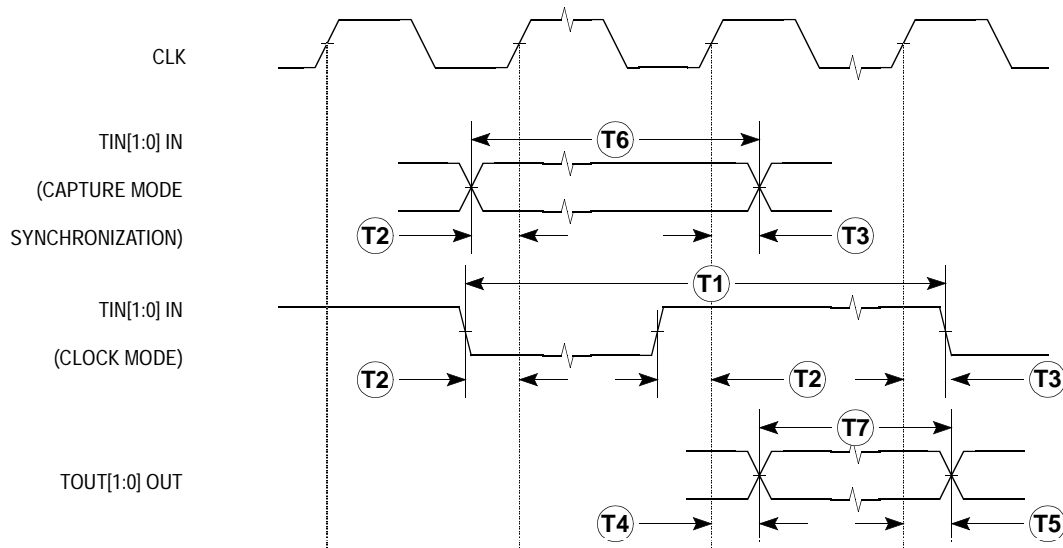

Figure 17-11. Timer Timing

17.3.10 UART Module AC Timing Specifications

Table 17-10. UART Module AC Timing Specifications

NAME	CHARACTERISTIC	40 MHz		54 MHz		NAME
		MIN	MAX	MIN	MAX	
U1	RxD[2:1] Valid to CLK (Setup)	2	—	1.5	—	U1
U2	CLK to RxD[2:1] Invalid (Hold)	4.5	—	4.5	—	U2
U3	CTS[2:1] Valid to CLK (Setup)	2	—	1.5	—	U3
U4	CLK to CTS[2:1] Invalid (Hold)	4.5	—	4.5	—	U4
U5	CLK to TxD[2:1] Valid	3	21.5	3	16	U5
U6	CLK to TxD[2:1] Invalid (Output Hold)	3	—	3	—	U6
U7	CLK to $\overline{\text{RTS}}$ [2:1] Valid	3	18.5	3	15.5	U7
U8	CLK to $\overline{\text{RTS}}$ [2:1] Invalid (Output Hold)	3	—	3	—	U8

17.3.11 UART Module Timing Diagram

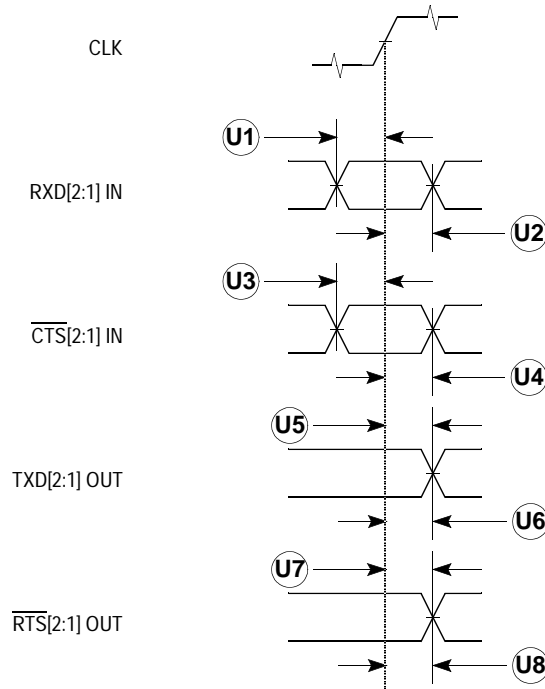

Figure 17-12. UART Timing

17.3.12 M-BUS Module AC Timing Specifications

17.3.12.1 INPUT TIMING SPECIFICATIONS BETWEEN SCL AND SDA.

Table 17-11. INPUT Timing Specifications Between SCL and SDA

NAME	CHARACTERISTIC	40 MHz		54 MHz		UNIT
		MIN	MAX	MIN	MAX	
M1 ¹	Start condition hold time	2	—	2	—	CLKs
M2 ¹	Clock low period	8	—	8	—	CLKs
M3	SCL/SDA rise time (from $V_i=0.5V$ to $V_h=2.4V$)	—	1	—	1	us
M4	Data hold time	0	—	0	—	ns
M5	SCL/SDA fall time (from $V_h=2.4V$ to $V_l=0.5V$)	—	1	—	1	us
M6 ¹	Clock high time	4	—	4	—	CLKs
M7	Data setup time	0	—	0	—	ns
M8 ¹	Start condition setup time (for repeated start condition only)	2	—	2	—	CLKs
M9 ¹	Stop condition setup time	2	—	2	—	CLKs

¹ Note: Units for these specifications are in processor CLK units.

17.3.12.2 OUTPUT TIMING SPECIFICATIONS BETWEEN SCL AND SDA.

Table 17-12. Output Timing Specifications Between SCL and SDA

NAME	CHARACTERISTIC	40 MHz		54 MHz		UNIT
		MIN	MAX	MIN	MAX	
M1 ^{1,2}	Start condition hold time	6	—	6	—	CLKs
M2 ^{1,2}	Clock low period	10	—	10	—	CLKs
M3 ³	SCL/SDA rise time (from $V_i=0.5V$ to $V_i=2.4V$)	—	—	—	—	us
M4 ^{1,2}	Data hold time	7	—	7	—	CLKs
M5 ⁴	SCL/SDA fall time (from $V_i=2.4V$ to $V_i=0.5V$)	—	TBD	—	TBD	us
M6 ^{1,2}	Clock high time	10	—	10	—	CLKs
M7 ^{1,2}	Data setup time	2	—	2	—	CLKs
M8 ^{1,2}	Start condition setup time (for repeated start condition only)	20	—	20	—	CLKs
M9 ^{1,2}	Stop condition setup time	10	—	10	—	CLKs

¹ Note: Units for these specifications are in processor CLK units.

² Note: Output numbers are dependent on the value programmed into the MFDR; an MFDR programmed with the maximum frequency (MFDR = 0x20) will result in minimum output timings as shown in the above table. The MBUS interface is designed to scale the actual data transition time to move it to the middle of the SCL low period. The actual position is affected by the prescale and division values programmed into the MFDR; however, numbers given in the above table are the minimum values.

³ Since SCL and SDA are open-collector-type outputs, which the processor can only actively drive low, the time required for SCL or SDA to reach a high level depends on external signal capacitance and pull-up resistor values.

⁴ Specified at a nominal 50pF load.

17.3.12.3 TIMING SPECIFICATIONS BETWEEN CLK AND SCL, SDA.

Table 17-13. Timing Specifications Between CLK and SCL, SDA

NAME	CHARACTERISTIC	40 MHz		54 MHz		UNIT
		MIN	MAX	MIN	MAX	
M10	SCL, SDA Valid to CLK (Setup)	5.5	—	4	—	ns
M11	CLK to SCL, SDA Invalid (Hold)	4.5	—	4.5	—	ns
M12 ¹	CLK to SCL, SDA Valid Low	3	18.5	3	14	ns
M13 ²	CLK to SCL, SDA Invalid (Output Hold)	3	—	3	—	ns

¹ Since SCL and SDA are open-collector-type outputs, which the processor can only actively drive low, this specification applies only when SCL or SDA are driven low by the processor. The time required for SCL or SDA to reach a high level depends on external signal capacitance and pull-up resistor values.

² Since SCL and SDA are open-collector-type outputs, which the processor can only actively drive low, this specification applies only when SCL or SDA are actively being driven or held low by the processor.

17.3.13 M-Bus Module Timing Diagram

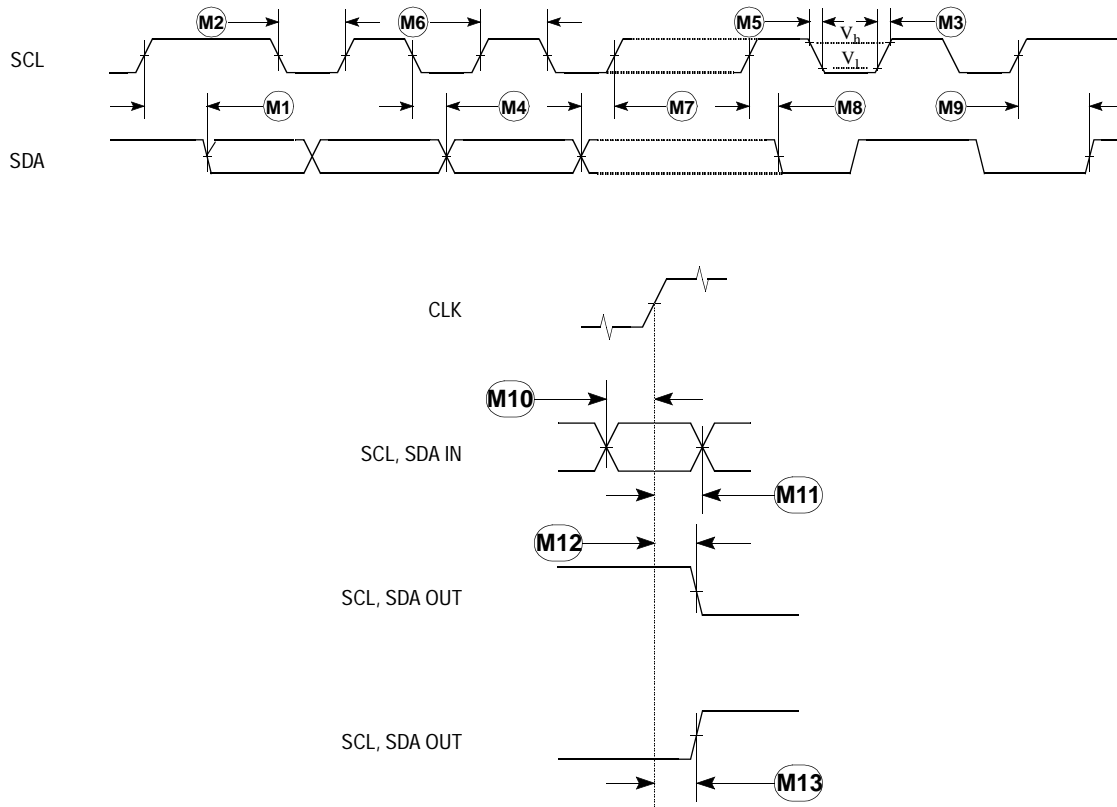

Figure 17-13. M-Bus Timing

17.3.14 General-Purpose I/O Port AC Timing Specifications

Table 17-14. General-Purpose I/O Port AC Timing Specifications

NAME	CHARACTERISTIC	40 MHz		54 MHz		UNIT
		MIN	MAX	MIN	MAX	
P1	PP[7:0] input setup time to CLK (rising)	3	—	2	—	ns
P2	PP[7:0] input hold time from CLK (rising)	4.5	—	4.5	—	ns
P3	CLK to PP[7:0] Output Valid	3	19.5	3	17	ns
P4	CLK to PP[7:0] Output Invalid (Output Hold)	3	—	3	—	ns

17.3.15 General-Purpose I/O Port Timing Diagram

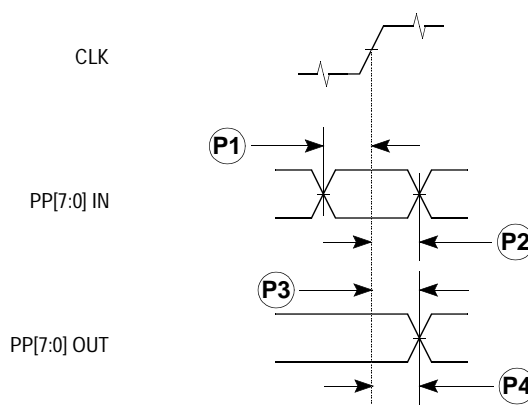

Figure 17-14. General-Purpose I/O Port Timing

17.3.16 DMA Controller AC Timing Specifications

Table 17-15. DMA Controller AC Timing

NAME	CHARACTERISTIC	40 MHz		54 MHz		UNIT
		MIN	MAX	MIN	MAX	
D1	DREQ Valid to CLK (Setup)	4	—	2.5	—	ns
D2	CLK to DREQ Invalid (Hold)	4.5	—	4.5	—	ns

17.3.17 DMA Controller Timing Diagram

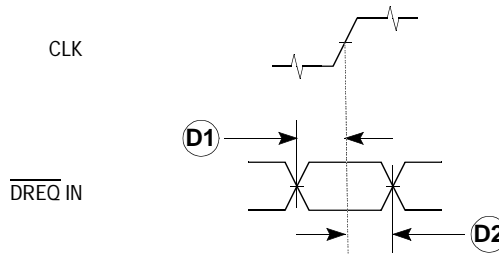

Figure 17-15. DMA Timing

17.3.18 IEEE 1149.1 (JTAG) AC Timing Specifications

Table 17-16. IEEE 1149.1 (JTAG) AC Timing Specifications

NAME	CHARACTERISTIC	40 MHz		54 MHz		UNIT
		MIN	MAX	MIN	MAX	
—	TCK frequency of operation	0	10	0	10	MHz
J1	TCK cycle time	100	—	100	—	ns
J2a	TCK clock pulse high width measured at 1.5V	40	—	40	—	ns
J2b	TCK clock pulse low width measured at 1.5V	40	—	40	—	ns
J3a	TCK fall time (from $V_H = 24V$ to $V_L = 0.5V$)	—	5	—	5	ns
J3b	TCK rise time (from $V_L = 0.5V$ to $V_H = 24V$)	—	5	—	5	ns
J4	TDI, TMS to TCK rising (Setup)	10	—	10	—	ns
J5	TCK rising edge to TDI, TMS Invalid (Hold)	15	—	15	—	ns
J6	Boundary scan data valid to TCK rising edge (Setup)	10	—	10	—	ns
J7	Boundary scan data invalid to TCK rising edge (Hold)	15	—	15	—	ns
J8	TRST pulse width (asynchronous to clock edges)	15	—	15	—	ns
J9	TCK falling edge to TDO valid (signal from driven or three-state)	—	30	—	30	ns
J10	TCK falling edge to TDO high impedance	—	30	—	30	ns
J11	TCK falling edge to boundary scan data valid (signal from driven or three-state)	—	35	—	35	ns
J12	TCK falling edge to boundary scan data high impedance	—	35	—	35	ns

17.3.19 IEEE 1149.1 (JTAG) Timing Diagram

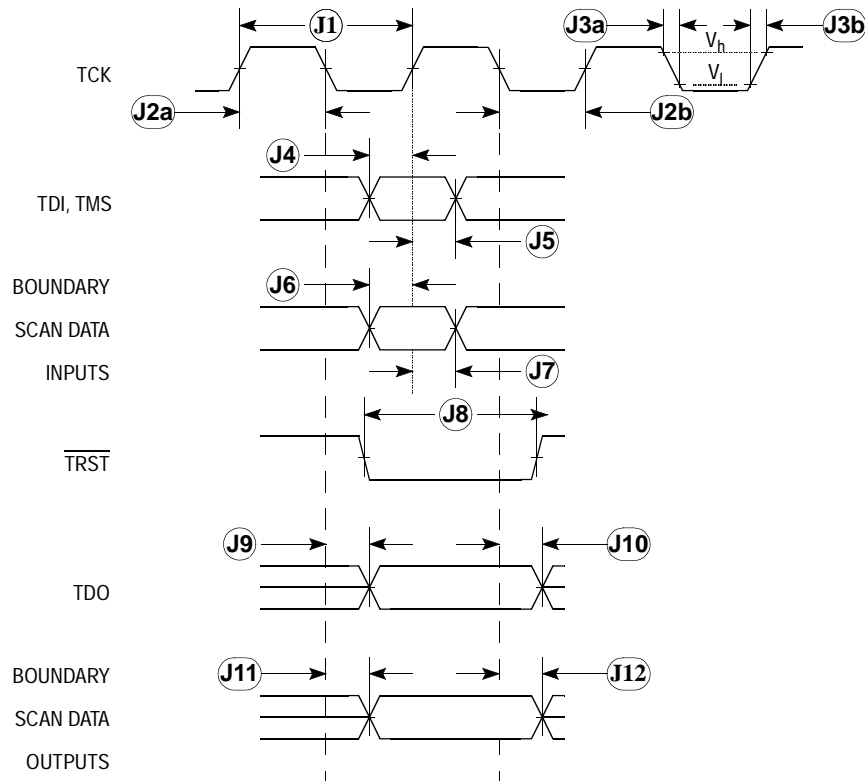
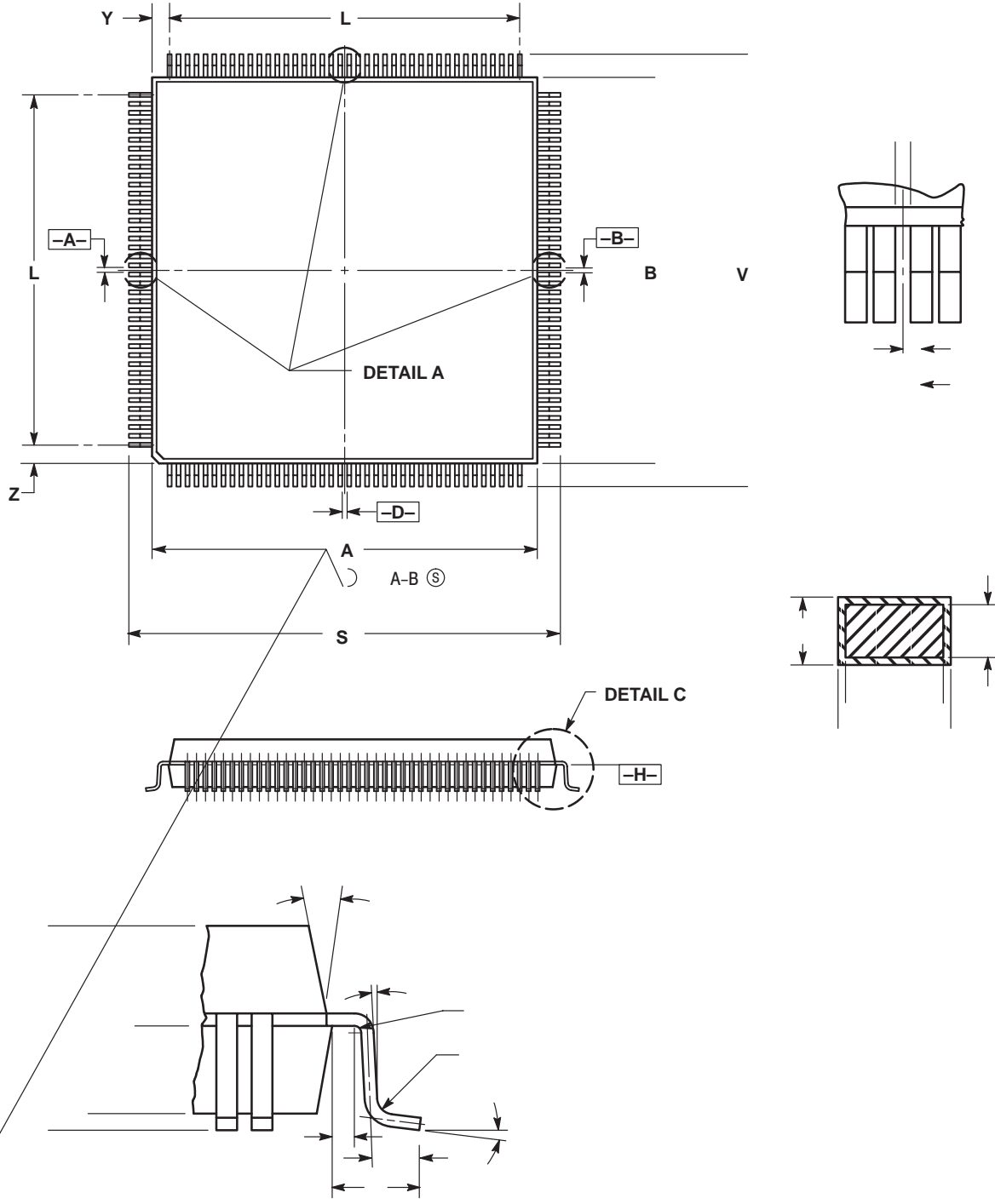

Figure 17-16. IEEE 1149.1 (JTAG) Timing

SECTION 18 MECHANICAL DATA



18.1 PACKAGE DIAGRAM & PINOUT

The MCF5206e is supplied in a 160-pin plastic quad flat pack package as shown:

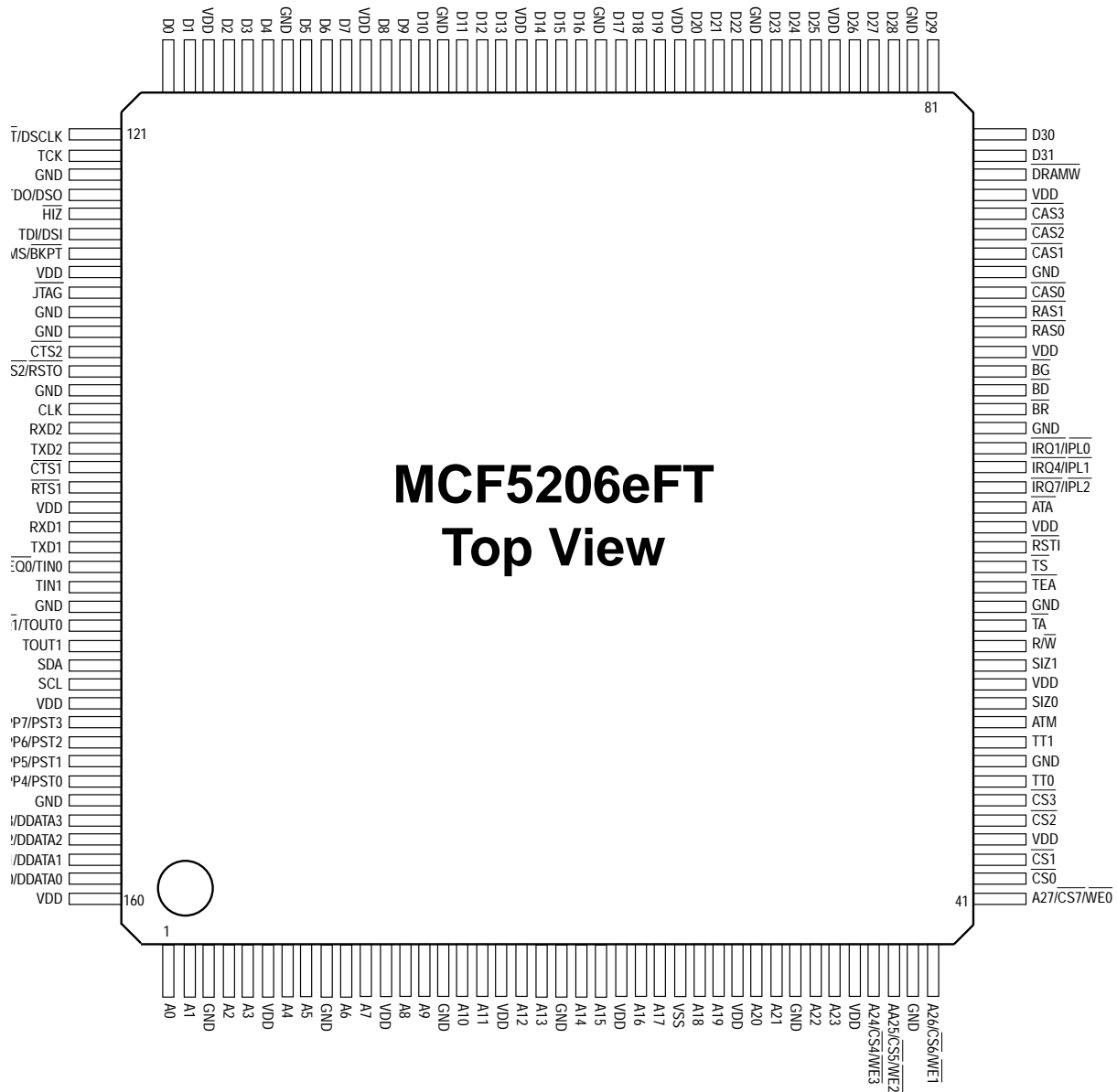

Figure 18-1. MCF5206e Package Diagram & Pinout

18.1.1 Package/Frequency Availability

The following table identifies the packages and operating frequencies available for the MCF5206e processor.

Table 18-1. MCF5206e Package/Frequency Availability

Package	Frequency	Temperature	Part Number
Plastic Quad Flat Pack 160 lead	40, and 54 MHz	0 to 70 C	MCF5206E
Plastic Quad Flat Pack 160 lead	40 MHz	-40 to +85 C	

18.2 DOCUMENTATION

All MCF5206e information is available on the WWW at <http://sps.motorola.com/coldfire>. Hard copy information is available from Motorola literature distribution centers.

Table 18-2. MCF5206e Documentation

Document Number	Document Title
MCF5206e/D	MCF5206e Product Brief (Currently available)
MCF5206eUM/D	MCF5206e User's Manual (Est. Stocking LDC July 98)
MCF5200PRM/AD	MCF5200 ColdFire Family Programmer's Reference Manual Rev. 1.0 (Currently available)

18.3 DEVELOPMENT TOOLS

Development tools for the MCF5206e processor consist of a complete suite of compilers and debuggers available from third-party developers, as shown in the tables below. Any development tool that generates code for the Motorola ColdFire MCF5206 can do the same for the MCF5206e processor.

Table 18-3. Development Tools Providers

COMPILERS/DEBUGGERS		
Diab Data	415-571-1700	Now
Software Development Systems	708-368-0400	Now
RTOS		
Integrated Systems	408-542-1781	Now
Embedded System Products	617-828-5588	Now
Wind River Systems	510-748-4100	Now
EMULATORS		
Yokogawa/Orion Instruments	408-747-0440	Now
Embedded Support Tools (EST)	617-828-5588	Now
Noral Micrologics	508-647-1013	
Lauterbach	508-620-4521	Now
Microtek	503-645-7333	Now
LOGIC ANALYZERS		
Hewlett-Packard (preprocessors only)	719-590-2558	Now
DEVELOPMENT BOARDS		
ORDER NUMBER		
M5206 eAN	---	September 98

APPENDIX A MCF5206E MEMORY MAP SUMMARY

This section is a summary chart of the entire memory map for the MCF5206e.

Table A-1. MCF5206e User Programming Model

MBAR OFFSET ADDRESS	NAME	WIDTH	DESCRIPTION	RESET VALUE	ACCESS
MOVEC with \$C0F	MBAR	32	Module Base Address Register	uninitialized (except V=0)	W
\$003	SIMR	8	SIM Configuration Register	\$C0	R/W
\$014	ICR1	8	Interrupt Control Register 1 - External IRQ1/IPL1	\$04	R/W
\$015	ICR2	8	Interrupt Control Register 2 - External IPL2	\$08	R/W
\$016	ICR3	8	Interrupt Control Register 3 - External IPL3	\$0C	R/W
\$017	ICR4	8	Interrupt Control Register 4 - External IRQ4/IPL4	\$10	R/W
\$018	ICR5	8	Interrupt Control Register 5 - External IPL5	\$14	R/W
\$019	ICR6	8	Interrupt Control Register 6 - External IPL6	\$18	R/W
\$01A	ICR7	8	Interrupt Control Register 7 - External IRQ7/IPL7	\$1C	R/W
\$01B	ICR8	8	Interrupt Control Register 8 - SWT	\$1C	R/W
\$01C	ICR9	8	Interrupt Control Register 9 - Timer 1 Interrupt	\$80	R/W
\$01D	ICR10	8	Interrupt Control Register 10 - Timer 2 Interrupt	\$80	R/W
\$01E	ICR11	8	Interrupt Control Register 11 - MBUS Interrupt	\$80	R/W
\$01F	ICR12	8	Interrupt Control Register 12 - UART 1 Interrupt	\$00	R/W
\$020	ICR13	8	Interrupt Control Register 13 - UART 2 Interrupt	\$00	R/W
\$036	IMR	16	Interrupt Mask Register	\$3FFE	R/W
\$03A	IPR	16	Interrupt Pending Register	\$0000	R
\$040	RSR	8	Reset Status Register	\$80 or \$20	R/W
\$041	SYPCR	8	System Protection Control Register	\$00	R/W
\$042	SWIVR	8	Software Watchdog Interrupt Vector Register	\$0F	R/W
\$043	SWSR	8	Software Watchdog Service Register	uninitialized	W
\$046	DCRR	16	DRAM Controller Refresh	Master Reset: \$0000 Normal Reset: uninitialized	R/W
\$04A	DCTR	16	DRAM Controller Timing Register	Master Reset: \$0000 Normal Reset: uninitialized	R/W
\$04C	DCAR0	16	DRAM Controller Address Register - Bank 0	Master Reset: uninitialized Normal Reset: uninitialized	R/W
\$050	DCMR0	32	DRAM Controller Mask Register - Bank 0	Master Reset: uninitialized Normal Reset: uninitialized	R/W
\$057	DCCR0	8	DRAM Controller Control Register - Bank 0	Master Reset: \$00 Normal Reset: \$00	R/W
\$058	DCAR1	16	DRAM Controller Address Register - Bank 1	Master Reset: uninitialized Normal Reset: uninitialized	R/W

MBAR OFFSET ADDRESS	NAME	WIDTH	DESCRIPTION	RESET VALUE	ACCESS
\$05C	DCMR1	32	DRAM Controller Mask Register - Bank 1	Master Reset: uninitialized Normal Reset: uninitialized	R/W
\$063	DCCR1	8	DRAM Controller Control Register - Bank 1	Master Reset: \$00 Normal Reset: \$00	R/W
\$064	CSAR0	16	Chip-Select Address Register - Bank 0	0000	R/W
\$068	CSMR0	32	Chip-Select Mask Register - Bank 0	00000000	R/W
\$06E	CSCR0	16	Chip-Select Control Register - Bank 0	\$3C1F, \$3C5F, \$3C9F, \$3CDF, \$3D1F, \$3D5F, \$3D9F, or \$3DDF AAs _{set} by RO7 atreset PS1 _{set} by RO4 atreset PS0 _{set} by RO1 atreset	R/W
\$070	CSAR1	16	Chip-Select Address Register - Bank 1	uninitialized	R/W
\$074	CSMR1	32	Chip-Select Mask Register - Bank 1	uninitialized	R/W
\$07A	CSCR1	16	Chip-Select Control Register - Bank 1	uninitialized (except BRST=ASET=WRAH=RDAH= WR=RD=0)	R/W
\$07C	CSAR2	16	Chip-Select Address Register - Bank 2	uninitialized	R/W
\$080	CSMR2	32	Chip-Select Mask Register - Bank 2	uninitialized	R/W
\$086	CSCR2	16	Chip-Select Control Register - Bank 2	uninitialized (except BRST=ASET=WRAH=RDAH= WR=RD=0)	R/W
\$088	CSAR3	16	Chip-Select Address Register - Bank 3	uninitialized	R/W
\$08C	CSMR3	32	Chip-Select Mask Register - Bank 3	uninitialized	R/W
\$092	CSCR3	16	Chip-Select Control Register - Bank 3	uninitialized (except BRST=ASET=WRAH=RDAH= WR=RD=0)	R/W
\$094	CSAR4	16	Chip-Select Address Register - Bank 4	uninitialized	R/W
\$098	CSMR4	32	Chip-Select Mask Register - Bank 4	uninitialized	R/W
\$09E	CSCR4	16	Chip-Select Control Register - Bank 4	uninitialized (except BRST=ASET=WRAH=RDAH= WR=RD=0)	R/W
\$0A0	CSAR5	16	Chip-Select Address Register - Bank 5	uninitialized	R/W
\$0A4	CSMR5	32	Chip-Select Mask Register - Bank 5	uninitialized	R/W
\$0AA	CSCR5	16	Chip-Select Control Register - Bank 5	uninitialized (except BRST=ASET=WRAH=RDAH= WR=RD=0)	R/W
\$0AC	CSAR6	16	Chip-Select Address Register - Bank 6	uninitialized	R/W
\$0B0	CSMR6	32	Chip-Select Mask Register - Bank 6	uninitialized	R/W
\$0B6	CSCR6	16	Chip-Select Control Register - Bank 6	uninitialized (except BRST=ASET=WRAH=RDAH= WR=RD=0)	R/W
\$0B8	CSAR7	16	Chip-Select Address Register - Bank 7	uninitialized	R/W
\$0BC	CSMR7	32	Chip-Select Mask Register - Bank 7	uninitialized	R/W
\$0C2	CSCR7	16	Chip-Select Control Register - Bank 7	uninitialized (except BRST=ASET=WRAH=RDAH= WR=RD=0)	R/W

MBAR OFFSET ADDRESS	NAME	WIDTH	DESCRIPTION	RESET VALUE	ACCESS
\$0C6	DMCR	16	Default Memory Control Register	0000	R/W
\$0CA	PAR	16	Pin Assignment Register	\$00	R/W
\$100	TMR1	16	Timer 1 Mode Register	\$0000	R/W
\$104	TRR1	16	Timer 1 Reference Register	\$FFFF	R/W
\$108	TCR1	16	Timer 1 Capture Register	\$0000	R
\$10C	TCN1	16	Timer 1 Counter	\$0000	R/W
\$111	TER1	8	Timer 1 Event Register	\$00	R/W
\$120	TMR2	16	Timer 2 Mode Register	\$0000	R/W
\$124	TRR2	16	Timer 2 Reference Register	\$FFFF	R/W
\$128	TCR2	16	Timer 2 Capture Register	\$0000	R
\$12C	TCN2	16	Timer 2 Counter	\$0000	R/W
\$131	TER2	8	Timer 2 Event Register	\$00	R/W
\$140	UMR1,2	8	UART 1 Mode Registers	\$00	R/W
\$144	USR/ UCSR	8	UART 1 Status Register (R/W=1)/ UART 1 Clock-Select Register (R/W=0)	USR=\$00; UCSR=\$DD	USR=R; UCSR=W
\$148	UCR	8	UART 1 Command Register	\$00	W
\$14C	URB/UTB	8	UART 1 Receive Buffer (R/W=1)/ UART 1 Transmit Buffer (R/W=0)	URB=\$FF; UTB=\$00	URB=R; UTB=W
\$150	UIPCR/ UACR	8	UART Input Port Change Register (R/w=1);/ UART 1 Auxiliary Control Register (R/W=0)	UIPCR=\$0F; UACR=\$00	UIPCR=R; UACR=W;
\$154	UISR/ UIMR	8	UART 1 Interrupt Status Register (R/W=1); UART 1 Interrupt Mask Register (R/W=0)	UISR=\$00; UIMR=\$00	UISR=R; UIMR=W
\$158	UBG1	8	UART 1 Baud Rate Generator Prescale MSB	uninitialized	W
\$15C	UBG2	8	UART 1 Baud Rate Generator Prescale LSB	uninitialized	W
\$170	UIVR	8	UART 1 Interrupt Vector Register	\$0F	R/W
\$174	UIP	8	UART 1 Input Port Register	\$FF	R
\$178	UOP1	8	UART 1 Output Port Bit Set CMD	UOP1[7:1]= undefined; UOP1=0	W
\$17C	UOP0	8	UART 1 Output Port Bit Reset CMD	uninitialized	W
\$180	UMR1,2	8	UART 2 Mode Registers	\$00	R/W
\$184	USR/ UCSR	8	UART 2 Status Register (R/W=1)/ UART 1 Clock-Select Register (R/W=0)	USR=\$00; UCSR=\$DD	USR=R; UCSR=W
\$188	UCR	8	UART 2 Command Register	\$00	W
\$18C	URB/UTB	8	UART 2 Receive Buffer (R/W=1)/ UART 1 Transmit Buffer (R/W=0)	URB=\$FF; UTB=\$00	URB=R; UTB=W
\$190	UIPCR/ UACR	8	UART 2 Input Port Change Register (R/w=1);/ UART 1 Auxiliary Control Register (R/W=0)	UIPCR=\$0F; UACR=\$00	UIPCR=R; UACR=W;
\$194	UISR/ UIMR	8	UART 2 Interrupt Status Register (R/W=1); UART 1 Interrupt Mask Register (R/W=0)	UISR=\$00; UIMR=\$00	UISR=R; UIMR=W
\$198	UBG1	8	UART 2 Baud Rate Generator Prescale MSB	uninitialized	R/W
\$19C	UBG2	8	UART 2 Baud Rate Generator Prescale LSB	uninitialized	R/W
\$1B0	UIVR	8	UART 2 Interrupt Vector Register	\$0F	R/W
\$1B4	UIP	8	UART 2 Input Port Register	\$FF	R
\$1B8	UOP1	8	UART 2 Output Port Bit Set CMD	UOP1[7:1]= undefined; UOP1=0	W
\$1BC	UOP0	8	UART2 Output Port Bit Reset CMD	uninitialized	W
\$1C5	PPDDR	8	Port A Data Direction Register	\$00	R/W

MBAR OFFSET ADDRESS	NAME	WIDTH	DESCRIPTION	RESET VALUE	ACCESS
\$1C9	PPDAT	8	Port A Data Register	\$00	R/W
\$1E0	MADR	8	M-Bus Address Register	\$00	R/W
\$1E4	MFDR	8	M-Bus Frequency Divider Register	\$00	R/W
\$1E8	MBCR	8	M-Bus Control Register	\$00	R/W
\$1EC	MBSR	8	M-Bus Status Register	\$00	R/W
\$1F0	MBDR	8	M-Bus Data I/O Register	\$00	R/W
\$200	DMASAR0	32	Source Address Register 0	\$00	R/W
\$204	DMADAR0	32	Destination Address Register 0	\$00	R/W
\$208	DCR0	16	DMA Control Register 0	\$00	R/W
\$20C	BCR0	16	Byte Count Register 0	\$00	R/W
\$210	DSR0	8	Status Register 0	\$00	R/W
\$214	DIVR0	8	Interrupt Vector Register 0	\$0F	R/W
\$240	DMASAR1	32	Source Address Register 1	\$00	R/W
\$244	DMADAR1	32	Destination Address Register 1	\$00	R/W
\$248	DCR1	16	DMA Control Register 1	\$00	R/W
\$24C	BCR1	16	Byte Count Register 1	\$00	R/W
\$250	DSR1	8	Status Register 1	\$00	R/W
\$254	DIVR1	8	Interrupt Vector Register 1	\$0F	R/W

APPENDIX B

PORTING FROM M68000 FAMILY DEVICES

This section is an overview of the issues encountered when porting embedded development tools to ColdFire[®] devices when starting with the M68000 Family devices.

B.1 C COMPILERS AND HOST SOFTWARE

For the purpose of this discussion, it is assumed that an embedded software development tool chain consists of a “host” portion and a “target” portion. The host portion consists of tool chain parts that execute on a desktop computer or workstation. The target portion of the tool chain runs ColdFire executables on a physical ColdFire target board.

Compilers, assemblers, linkers, loaders, instruction set simulators, and the host portion of debuggers are examples of host tools. Many host tools such as linkers and loaders that work with the M68000 Family devices can also be used without modification with ColdFire processors.

Although you can use an existing M68000 Family assembler and disassembler with ColdFire devices, Motorola recommends modifying the assembler so that non-ColdFire assembly code cannot be put together in the executable. This is especially true if the assembler assembles handwritten code. Porting the disassembler is for convenience and can be performed later.

Debuggers usually are comprised of two parts. A host portion of the debugger typically issues higher level commands for the target portion of debugger target. The target portion of the debugger typically handles the exact details of the implementation of tracing, breakpoints, and other lower level details. The debugger host portion requires little modification. Most likely, the only architectural items of concern are the following:

- Differences in the designed supervisor registers and stack pointers (for displaying registers)
- Interpretation of exception stack frames (if not already performed by the target portion)

B.2 TARGET SOFTWARE PORT

Porting ROM monitors and operating systems can begin after the compiler and assembler have been ported. For example, consider the steps involved in porting a ROM debugger. Similar issues are encountered when porting an RTOS and target applications.

It is assumed that target software consists of C and assembly source code. The first step is to create executables that runs on existing M68000 Family hardware to test the conversion from M68000 Family code to the proper ColdFire subset. This step verifies that the process of code conversion does not introduce new errors.

To generate a ColdFire device executable of the target debugger, you should use a compliant port of the same C compiler originally used to create the M68000 Family debugger target. This procedure prevents differences in calling convention and parameter passing from C to handwritten assembly. Another advantage to this approach is that special C flags are retained. Many C compilers have special extensions as well.

Whichever approach is used, the assembly language lines that are outside the ColdFire instruction set must be identified. Any ColdFire assembler that properly flags nonColdFire instructions can be used. During the process of conversion, you can ignore instruction set issues temporarily because the target is still an M68000 Family member.

Once the instruction set differences have been resolved, the architectural differences between ColdFire devices and M68000 Family devices need to be addressed.

B.3 INITIALIZATION CODE

The target software and firmware often execute code that identifies the type of processor. Such a process provides one port that works with various M68000 Family members and implementations. The easiest way to identify the ColdFire architecture from other M68000 Family processors is to execute an ILLEGAL opcode (\$4AFC). This execution generates an exception stack frame while ensuring that the tracing is disabled. The first two bits of the exception stack frame would immediately determine whether the processor is a ColdFire processor.

Motorola suggests that ColdFire architecture testing be performed immediately to avoid executing potentially undefined opcodes. Unused opcodes in the Version 2 ColdFire architecture are not guaranteed to result in an illegal instruction exception.

Another item to consider is that the ColdFire architecture will have integrated versions with modules yet to be defined. It may be a good idea to ensure that there are enough hooks to allow for initialization of routines.

B.4 EXCEPTION HANDLERS

When dealing with exceptions in debug-oriented software, it is often necessary to extract exception stack information to obtain the SR and PC. The format word (MC68010 and higher) is typically used by generalized exception routines. Their sole purpose is to catch unexpected exceptions and to easily use vector information to identify the cause of the exception. The MC68000 exception frame is different from that of other members of the M68000 Family processors in that there is no notion of a format word. This difference would have forced target software to deal with exception stack frame differences already. The approach now in use provides guidance on handling exception stack frame differences. In many low-level exception handlers, the extraction of the stacked SR, PC, or format word is performed in a common source file or the offsets are handled in some type of header file.

Interrupt handlers probably require no modification because in most cases, an interrupt occurs asynchronously with respect to normal program flow. Therefore, interrupt handlers cannot rely on items on the stack as it is often unnecessary to know exactly what was happening at the time of the interrupt.

System calls are often implemented by using the TRAP instruction. For trap exceptions, parameter passing is performed through data and address registers—rarely, if ever, directly through the stack. In addition, a system call typically does not need to know the stacked SR or PC information.

Breakpoints are usually implemented with the TRAP instruction or an illegal instruction such as an \$A-line exception. If so, the stacked SR and PC are typically used. Other items in the stack may also need to be queried, especially if the breakpoint displays a stack trace. If so, you should examine the format closely for stack misalignments at the time of the breakpoint. This stack misalignment check would be useful in applications where stack alignment is a software design goal. These same concerns for the breakpoint implementation are applicable to trace exceptions as well.

A generalized exception handler can be implemented to catch unexpected exceptions. In addition to the SR and PC information, it is often necessary to obtain the vector information in the stack. Otherwise, the issues are similar to those found on breakpoints and tracing.

To port ColdFire processor access error exception, it is best to start with an MC68000 bus error handler. The ColdFire device access error recovery sequence has many similarities to the procedure recommended for the MC68000. However, you should be aware that a read bus error on the ColdFire processor will not advance the program counter to the next instruction. In addition, a write bus error may be taken long after an instruction has been executed and the stacked program counter may not point to the offending instruction. The main cause of an address error exception in the M68000 Family is that program flow is forced to continue at an odd address boundary. In addition, an MC68000 reports an address error if a data byte access is initiated on an odd address.

On a ROM monitor, it is often necessary to provide a means by which a user program is executed given a certain starting address. This is often implemented by placing an exception stack frame and then performing an RTE. If this is the case, the header files that define what a stack frame looks like would require modification to reflect the ColdFire stack frame format.

B.5 SUPERVISOR REGISTERS

The target software would eventually need to communicate the contents of registers to the host software. Both the host portions and target portions of a debugger must be modified to reflect the single stack pointer architecture of the ColdFire Family. In addition, the target debugger must keep a copy of the MOVEC register images in memory so that it can provide the host software register contents when asked to do so. A UNIX *grep* utility can find all instances of the MOVEC instruction and perform the appropriate modifications to accommodate the unidirectional MOVEC instruction.

The ColdFire architecture does not distinguish between a supervisor stack and a user stack. There is only a single stack pointer, A7. One way of dealing with this issue is to emulate the dual stacks by placing some code at the beginning and end portions of exception handlers to change the stack pointer contents, if necessary, during exceptions. This approach has the disadvantage that interrupt latency would be degraded because interrupts would have to be disabled during the stack-swapping process, but enable full flexibility of the 68K stack model.

INDEX

A

AABR 15-32, 15-33
 AATR 15-28
 ABLR/ABHR 15-28
 Access Control Registers 4-8
 access error 1-6, 8-3
 on operand writes 3-9
 Access Fault Exception 8-2, 9-39
 Access Type and Mode (ATM) 6-3
 ACR0, ACR1 4-3, 4-8
 Address / Data (A/D) Field 15-10
 Address Attribute Breakpoint Register (AATR) 15-13, 15-15, 15-30
 address bus 2-3, 2-4
 address error 1-6
 Address Error Exception 3-9
 address hold 9-8, 9-34
 Address masking 9-5
 Address Multiplexing 11-8
 address multiplexing for external master transfers 11-41
 address setup 9-8, 9-11, 9-34
 address setup and hold features 9-22
 Address Space Masks 8-8
 Addressing Modes
 index sizing and scaling 1-10
 program counter indirect 1-10
 register indirect 1-10
 aligned and misaligned operand references 15-33
 aligned transfers 6-67
 alignment 6-48
 alternate master transfers 2-9, 6-68, 11-41
 Arbitration 13-8, 13-10
 arbitration states 6-66
 Asynchronous Acknowledge 6-29, 6-34
 Asynchronous Transfer Acknowledge (ATA) 2-10, 6-4, 6-30, 6-47, 6-52
 ATM 2-9
 Automatic Echo 12-19
 autovector 8-4, 8-5, 8-6, 8-10
 autovectored interrupt 8-4
 Autovectoring 3-10, 6-49

B

Bank Page Size 11-61
 Base Address 11-58
 Base Address Mask 11-59

Baud-Rate Generator 12-5
 BDM command 15-29
 BDM Command Set Summary 15-8
 BDM connector 15-38
 BDM Serial Interface 15-6
 Bits per Character 12-19
 BKPT 2-18, 15-36
 BKPT input pin 15-5
 block mode 12-11, 12-18
 break condition 12-9
 Breakpoint Registers 15-28, 15-30
 breakpoint response (table 16-8) 15-26
 Breakpoint Status 15-35
 burst page mode 11-32, 11-47, 11-53, 11-54, 11-57
 burst transfer
 fast page mode 11-21
 normal mode 11-18
 burst transfers 4-7, 6-9, 6-16, 6-74, 9-7, 9-22, 11-44
 burst transfers and chip selects 9-13
 bursting 6-9
 burst-inhibited transfer 6-22, 6-16, 6-62
 Burst-Inhibited Write Transfer 6-26
 bus arbitration 2-11, 11-30
 operation, 6-54
 protocol, 6-54, 6-61
 Bus Driven (BD) 2-12
 bus error 6-52, 7-11
 Bus Grant (BG) 2-11
 bus interface 6-1
 bus lock 8-9
 bus lock bit 2-11
 bus monitor 8-2, 8-15
 Bus Request (BR) 2-11
 Bus Sizing 6-7, 9-7
 Bus Timeout Monitor 8-9, 8-13
 BYPASS Instruction 16-5

C

Cache Coherency 4-3
 Cache Control Register 4-6
 Cache Freeze 4-7
 Cache Invalidate 4-3, 4-7
 cache line filling 6-16
 Cache Miss Fetch Algorithm 4-4
 CACR 4-3, 4-6
 calling address 13-3, 13-10
 calling master 13-4
 Capture Edge 14-4

- Capture Event 14-6
 - Capture Mode 14-3
 - CAS and RAS 11-57
 - CAS Precharge Time 11-57
 - CAS timing 11-3
 - CCR 3-3
 - change-of-flow operations 15-2
 - changing receiver configuration 12-25
 - Channel prioritization 7-14
 - character mode 12-11, 12-18
 - Chip Select Address Register (CSAR0-CSAR7) 9-28
 - chip selects 1-17, 2-4, 2-5, 9-5, 9-7
 - Chip-Select Control Register (CSCR0 -7) 9-31
 - Chip-Select Control Register 0 (CSCR0) 6-85, 9-8
 - Chip-Select Mask Register (CSMR0-CSMR7) 9-29
 - chip-selects 8-16, 9-1
 - access permission 9-6
 - alternate master operation, 9-20
 - description 2-4
 - programming model, 9-26
 - CLAMP Instruction 16-5
 - clear-to-send operation 12-6
 - CLK 2-12
 - ColdFire BDM Commands 15-9
 - Column Address Strobe Time 11-56
 - Column Address Strobes 2-13
 - Command
 - format 15-12
 - Sequence Diagram 15-11
 - Concurrent BDM and Processor Operation 15-28
 - Condition Code Register 3-3
 - Configuration/Status Register (CSR) 15-35
 - Continuous Mode 7-12
 - Control Register Map 15-22
 - CPU Halt 15-4
 - CPU privilege level 15-37
 - CTS 12-28
 - Cycle Steal 7-12
- D**
- Data
 - Registers 15-13, 15-25
 - Data Breakpoint Register (DBR, DBMR) 15-32
 - data bus 2-4, 6-2
 - data formats 1-10
 - Data Registers 3-2
 - data transfer
 - alternate master 6-68
 - asynchronous-acknowledge 6-29, 6-32
 - bursting read 6-34
 - bursting word-read, 6-16, 6-18
 - bursting write 6-19, 6-37
 - burst-inhibited read, 6-22, 6-41
 - burst-inhibited write 6-44
 - longword-read 6-12
 - longword-write 9-9
 - operation, 6-6
 - word-write 6-15
 - DBR/DBMR 15-28
 - DDATA pins 15-2
 - Debug Control Registers (DRc) 15-29
 - Debug Data 2-17
 - Debug Interrupt 3-10
 - Debug mode 16-2, 16-8
 - debug module 2-17
 - BDM connector 15-38
 - command set 15-7
 - emulator mode 15-27
 - hardware reuse 15-28
 - interrupt 15-26
 - processor status 15-2
 - programming model 15-29
 - real-time debug 15-26
 - registers
 - address attribute breakpoint (AABR) 15-32, 15-33
 - serial interface 15-6
 - signals 2-16
 - theory of operation 15-26
 - Debug Programming Model 15-29
 - Debug Support
 - real-time debug support
 - theory of operation 15-26
 - debug module hardware 15-28
 - reuse of debug module hardware (Rev. A) 15-28
 - shared BDM/breakpoint hardware (table 16-9) 15-28
 - emulator mode 15-27
 - Default Memory 9-5, 9-38, 9-41
 - Default Memory Control Register (DMCR) 9-38
 - Definition of DRc Encoding - Write 15-25
 - Development Serial Clock 2-17
 - Development Serial Input 2-18
 - Development Serial Output 2-18
 - Differences Between ColdFire and CPU32 BDM 15-38
 - Disable command 12-6
 - Disabling IEEE 1149.1 Standard Operation 16-8
 - DMA
 - Channel
 - Initialization 7-14
 - Programming Sequence 7-14
 - DMA acknowledge 7-16
 - DMA channels 1-16
 - DMA Module 2-15
 - DMA Request 2-15, 7-3
 - Double Bus Fault 6-5
 - DRAM 6-4, 6-5, 6-16, 6-22, 11-58, 11-59, 11-60

access permissions 11-7
 alternate master use 11-40, 11-50, 11-60
 burst page mode 11-32, 11-47, 11-54
 bus arbitration 11-30
 fast page mode 11-21, 11-50, 11-54, 11-56
 initialization 11-61
 limitations 11-50
 normal mode operation 11-15, 11-41, 11-53
 page hit 11-23, 11-25
 page miss 11-27
 programming model 11-50
 refresh operation 11-38
 signals 2-13
 DRAM accesses 2-10
 DRAM controller 1-16, 6-81, 11-4, 11-13, 11-50
 DRAM Controller Address Registers (DCAR0-1) 11-58
 DRAM Controller Control Register (DCCR0-1) 11-60
 DRAM Controller Mask Register (DCMR0-1) 11-59
 DRAM controller refresh 2-12
 DRAM Controller Refresh Register (DCRR) 11-51
 DRAM Controller Timing Register 11-4
 DRAM Controller Timing Register (DCTR) 11-52
 DRAM Page Size 11-13
 DRAM port size 2-13
 DRAM write cycles 2-14
 DRAMs 11-13
 DSCLK 15-6
 DSI 15-6
 DSO 15-6
 Dual-Address
 Transfer 7-5
 dummy read 13-14
 Dump Memory Block (DUMP) 15-16

E

EDO DRAM 11-35, 11-53, 11-56, 11-57
 emulator mode 15-27, 15-36
 Enable Interrupt 14-4
 encoding 2-9
 error checking 7-14
 error detection 12-14
 Exception processing 1-6, 3-2, 3-5
 exception stack frame 3-6
 exception vector table 3-6
 exceptions
 access errors 1-6
 bus 6-5
 debug interrupt 15-26
 Extended Data-Out 11-52
 Extended Data-Out (EDO) DRAM 11-35
 Extension Word 15-10
 external arbiter 6-54
 External Bus 1-17

external bus master 6-54
 external clock source 12-5
 External DMA Request 7-8
 external interrupts 6-50
 external master 2-3, 2-4, 2-10, 9-40
 DRAM 11-31
 external master transfer 9-31
 EXTEST Instruction 16-3

F

fast page mode 11-21, 11-27, 11-50, 11-53, 11-54, 11-56, 11-57
 fault-on-fault 3-11
 FIFO Full 12-23
 FIFO stack 12-11
 FIFO-full status bit 12-11
 fill buffer 4-1
 Fill Memory Block (FILL) 15-19
 format value 3-10
 Framing Error 12-9, 12-22
 Free Run 14-4

G

General-Purpose I/O 2-16
 global (boot) chip select 9-31
 global chip select 2-5, 9-1
 Global Chip Select Operation 9-8

H

halt 15-4
 halted state 3-11
 hardware breakpoint 2-18, 15-36
 hardware divide 1-15
 hardware divider 3-4
 hardware reset 5-3, 6-81, 8-3
 High Impedance 2-20

I

I/O Driver Example 12-33
 I²C 1-16
 IDCODE 16-4
 IDcode Register 16-5
 ILLEGAL 15-25
 illegal command 15-10
 Illegal Instruction Exception 3-9
 implicit ownership state 6-61
 initiate communication 13-3
 Input Clock Source 14-4
 instruction cache 1-15, 4-1
 instruction execution times 3-11

Instruction Fetch Pipeline 3-2, 15-28
 Instructions
 STOP 1-6
 TRAP 1-6
 internal peripheral interrupt 8-6
 internal reset 6-81, 6-84
 interrupt acknowledge cycle 6-49, 6-50, 6-52, 8-5, 8-6, 9-1, 12-16
 interrupt acknowledge vector 6-49
 Interrupt Control 1-17, 8-3, 12-3
 Interrupt Control Register (ICR) 8-9
 interrupt exception 3-10, 6-49
 interrupt input signals 6-49
 interrupt level 8-5, 8-9
 Interrupt Mask Register (IMR) 8-5, 8-11
 interrupt masking 6-49
 interrupt priorities 3-5, 8-4, 8-6, 8-9
 interrupt priority level 2-7
 interrupt request 14-6
 Interrupt request encodings 2-8
 interrupt request pins 2-7
 interrupt signals 2-5
 Interrupt Vector Register 12-31
 interrupt-acknowledge (IACK) 3-6
 interrupt-acknowledge access 6-1
 Interrupt-Pending Register (IPR) 8-12
 interrupts 1-6
 debug 15-26
 external 8-4, 8-6
 handling 12-33
 M-BUS 8-5
 requests (UART) 12-3
 software watchdog 8-3, 8-5
 spurious 8-2
 timer 8-5
 UART 8-5
 IPLx 6-85

J

JTAG 1-18, 16-2
 boundary-scan register, 16-6
 BYPASS instruction, 16-5
 CLAMP instruction 16-5
 HIGHZ instruction 16-4
 IDCODE instruction 16-4
 IDcode register 16-5
 Restrictions 16-7
 SAMPLE/PRELOAD instruction 16-4
 signals 2-18
 JTAG BOUNDARY-SCAN REGISTER 16-6
 JTAG BYPASS REGISTER 16-6
 JTAG Instruction Shift Register 16-3
 JTAG mode 16-2, 16-8
 JTAG Pin Descriptions 16-2

L

line write 6-19
 line-fill buffer 4-1
 local loopback mode 2-15, 12-19, 12-27
 logical address space 1-10
 looping modes 12-12
 low-power stop mode 1-6

M

MAC 3-4
 MAC unit 1-15
 MADR 13-6
 Master Reset 6-81, 11-5
 master reset mode 2-12, 2-20
 master station 12-14
 Master/Slave Mode Select 13-8
 maximum period 14-2
 maximum resolution 14-2
 MBAR 8-1, 8-7, 11-61
 MBCR 13-8
 MBDR 13-11
 MBSR 13-9
 M-Bus 13-8, 13-10
 address register 13-6
 arbitration lost 13-14
 arbitration procedure 13-4
 clock stretching 13-5
 clock synchronization 13-5
 control register 13-8
 data I/O register 13-11
 data transfer 13-4
 frequency divider register 13-6
 generation of repeated START 13-14
 generation of START 13-11
 generation of STOP 13-13
 handshaking 13-5
 initialization sequence 13-11
 post-transfer software 13-12
 programming examples 13-11
 programming model 13-6
 protocol 13-3
 repeated START signal 13-4
 slave address transmission 13-3
 slave mode 13-14
 START signal 13-3
 status register 13-9
 STOP signal 13-4
 system configuration 13-2
 M-bus 2-16
 interrupts 8-5
 signals 2-16
 M-Bus contention
 slave service routine 13-15

M-Bus Interrupt 8-5, 13-8, 13-10
 M-Bus module 1-16
 M-Bus Serial Clock 2-16
 M-Bus Serial Data 2-16
 Memory-to-Memory Transfer 7-5
 MFDR 13-6
 Misaligned Operands 6-48
 Module Base Address Register 8-1
 Motorola Test Mode 2-20
 MOVEM 6-19
 MTMOD 2-17, 2-19
 multidrop mode 12-14, 12-18, 12-27
 Multiplexed Address 11-52

N

No Operation (NOP) 15-21
 nonburst external master accesses 9-22
 Nonburst transfers 11-16
 NOP instruction 3-9
 normal mode 11-15, 11-41, 11-45, 11-53
 Normal Reset 11-5, 11-40
 normal reset 6-81, 6-83, 11-5
 normal reset mode 2-12, 2-20
 not ready 15-11

O

Operand Execution Pipeline 3-2
 Operand Size 1-10, 15-10
 operation 6-9
 Operation Field 15-9
 Output Mode 14-3, 14-4
 Output Reference Event 14-6
 Output Reference Interrupt Enable 14-4
 overrun 12-12, 12-18
 overrun error 12-22

P

page hit Read 11-23
 Page Mode 11-8
 Page Mode Select 11-61
 Page-Hit Write Transfer 11-25
 parallel port 1-17
 signals 2-16, 8-16
 Parity Error 12-22
 Parity Mode 12-18
 Parity Type 12-18
 Pin Assignment Register (PAR) 8-16
 Pipeline Timing 15-3
 Pipelines 3-1
 port size 6-7, 9-7, 9-33, 11-60
 porting code 3-10

power dissipation 5-4
 power management 5-4
 power-on resets 2-20
 preload value the timer 12-31
 prescaler clock 14-3
 Prescaler Value 14-4
 privilege modes 1-6
 Privilege Violation 3-9
 privilege-violation exception 15-5
 Processing States
 normal, exception, halted, stopped 1-6
 Processor Status 2-16
 processor status outputs 15-2
 Program Counter Breakpoint Register (PBR, PBMR) 15-32
 PROGRAMMING 1-6
 programming model 1-6, 3-2
 cache 4-5
 chip-selects 9-26
 debug model 15-29
 DRAM 11-50
 parallel port 10-1
 supervisor 1-10
 UART 12-16
 user 1-9
 PST Definition 15-2
 PULSE opcode 15-3

R

R/W Field 15-9
 RAMBAR 5-2
 RAS Hold Time 11-54
 RAS Precharge Time 11-55
 RAS timing 11-1
 RAS-to-CAS Delay Time 11-53
 Read
 Memory Location Command 15-10
 Read A/D Register (RAREG/RDREG) 15-12
 Read Control Register (RCREG) 15-21
 Read Debug Register (RDREG) 15-23
 Read Memory Location (READ) 15-13
 Read Transfer 6-11
 Read/Write (R/W) 6-2
 Real-Time Debug Support 15-26
 Real-Time Trace 15-1
 receive buffer 12-11, 12-27
 Receive Data 2-14
 receive mode 13-12, 13-14
 Received Break 12-21
 receiver 12-12, 12-20
 Receiver Clock Select 12-24
 Receiver Disable 12-27
 Receiver Enable 12-27
 receiver FIFO 12-9

Receiver Interrupt 12-18
 Receiver Ready 12-23
 receiver shift register 12-11
 Reference Compare 14-3
 refresh cycles 11-57
 Refresh Operation 11-38
 refresh period 11-39, 11-52
 refresh rate 11-39, 11-52, 11-55
 Register Field 15-10
 Registers
 address registers 1-9
 condition code register 1-9
 index registers 1-9
 program counter 1-9
 stack pointer 1-9
 Status Register (SR)
 S-bit 1-6
 vector base register 1-10
 registers
 debug module
 AABR 15-32, 15-33
 AATR 15-28
 ABLR/ABHR 15-28
 DBR/DBMR 15-28
 Remote Loopback 12-19
 repeated START 13-9
 Request To Send 2-15, 12-6
 reset 9-8
 cache 4-4
 operation 6-81, 11-4
 RSTI pin 2-12, 6-81, 6-83, 15-5
 RSTO pin 2-12, 6-82, 6-83, 6-84
 Reset Break-Change Interrupt 12-25
 Reset Error Status 12-25
 reset exception 3-11
 reset exception processing 15-5, 15-36
 reset exception vector 3-2
 reset input 3-11
 Reset Mode Register Pointer 12-25
 Reset Out 2-12
 Reset Receiver 12-25
 Reset Status Register (RSR) 8-13
 Reset Timer 14-5
 Reset Transmitter 12-25
 Resume Execution (GO) 15-20
 Row Address Strokes 2-13
 RSTO 2-12
 RTE and Format Error Exceptions 3-10
 RTE instruction 15-27
 RTS 12-11

S

Signal sampling 6-5
 SIM Configuration Register (SIMR) 8-8

Single Address Transactions 7-13
 SIZx 6-9
 slave address 13-6
 slave stations 12-14
 software 11-5
 software watchdog interrupt 8-5
 Software Watchdog Interrupt Vector Register (SWIVR) 8-15
 Software Watchdog reset 6-81, 6-85
 Software Watchdog Service Register (SWSR) 8-16
 software watchdog timeout 2-13
 software watchdog timer 1-18, 6-84, 8-3, 8-7, 8-13, 8-14, 11-5
 Special Modes of Operation
 low-power stop mode 1-6
 spurious breakpoint triggers 15-28
 spurious interrupts 8-2, 8-19
 SR 3-4
 SRAM algorithm 5-3
 SRAM Base Address Register 5-2
 SRAM Initialization 5-3
 SRAM module 5-1
 SRAM register 5-1
 start bit 12-9
 Start Break 12-26
 status register 3-9
 status/control bit 15-7
 stop bit 12-9
 Stop Break 12-26
 STOP instruction 1-6, 3-9, 15-5
 stop signal 13-4
 Stop-Bit Length 12-20
 subroutine call 3-2
 supervisor mode 1-6, 3-2, 3-11
 Supervisor Programming Model 1-8, 3-4
 System Protection Control Register (SYPCR) 8-2, 8-13
 system reset 8-2

T

TAP Controller 16-6
 TCK 16-3, 16-8
 TDI 16-3
 TDO 16-3
 TEA 6-4
 terminate a data transfer 13-13
 Test Clock 2-18
 Test Data Input 2-19
 Test Data Output 2-19
 Test Mode Select 2-19
 Test Reset 2-18
 testing remote channel receiver and transmitter
 operation 12-13
 testing the operation of a local UART 12-12

three-wire mode 6-61
 Timer
 Programming Model 14-3
 timer 2-15, 12-3
 interrupts 8-5
 Timer Capture Register (TCR) 14-5
 Timer Counter (TCN) 14-5
 Timer Event Register (TER) 14-6
 Timer Input 2-15
 timer interrupts 8-5
 Timer Mode Register (TMR) 14-4
 timer module 1-16, 14-1
 block diagram 14-2
 Timer Output 2-15
 Timer Reference Register (TRR) 14-5
 TIN 14-3
 TMS 16-3
 Trace Exception 3-9
 Transfer Acknowledge (TA) 2-10, 6-4
 transfer data size 2-9
 Transfer Error Acknowledge (TEA) 2-11, 6-52
 transfer mask bit 9-30
 Transfer Start (TS) 2-10, 6-2
 Transfer type encodings 2-9
 Transmit Acknowledge 13-9
 Transmit Data 2-15
 transmit mode 13-12
 Transmit/Receive mode 13-8, 13-10
 transmitter 12-12, 12-20
 Transmitter Buffer 12-28
 Transmitter Clear-to-Send 12-20
 Transmitter Clock Select 12-24
 Transmitter Disable 12-26
 Transmitter Empty 12-23
 Transmitter Enable 12-26
 transmitter mode 13-14
 Transmitter Ready 12-23
 Transmitter Ready-to-Send 12-19
 transmitter serial data output 12-3
 TRAP 1-6
 TRAP instruction 3-10
 Trigger Definition Register (TDR) 15-33
 Trigger Response Control 15-33
 TRST 16-3, 16-8
 Two masters 6-54
 two-wire mode 6-54

U

UART 2-14, 12-3, 12-5
 bus operation 12-16
 interrupt acknowledge cycles 12-16
 interrupts 8-5
 programming model 12-16
 signals 2-14

UART Clock-Select Register (UCSR) 12-24
 UART Command Register (UCR) 12-24
 UART command register (UCR) 12-6, 12-9
 UART Input Port Change Register (UIPCR) 12-28
 UART Input Port Register (UIP) 12-32
 UART Interrupt Mask Register (UIMR) 12-30
 UART Interrupt Status Register (UISR) 12-29
 UART Interrupt Vector Register (UIVR) 12-31
 UART Mode Register 1 (UMR1) 12-17
 UART Mode Register 2 (UMR2) 12-19
 UART module
 I/O driver routines 12-33
 initialization routines 12-33
 timer upper preload registers 12-31
 timer/counter 12-3
 valid start bit 12-9
 UART Module Initialization 12-33, 12-34
 UART Output Port Data Register (UOP0-1) 12-32
 UART Receive Buffer (URB) 12-28
 UART Status Register (USR) 12-21
 UART Transmitter Buffer (UTB) 12-28
 UBG1, 2 12-31
 Unassigned Opcodes 15-25
 user mode 1-6, 3-2
 User Programming Model 1-8, 3-2
 USR 12-11

V

Vector Base Register (VBR) 3-5
 version number 16-4

W

WDEBUG 15-30
 WDMREG 15-30
 WRITE 15-19
 Write A/D Register (WAREG/WDREG) 15-12
 Write Control Register (WCREG) 15-23
 write cycle 6-2
 Write Debug Register (WDREG) 15-24
 write enables 2-5, 8-16, 9-1
 encoding 9-2
 Write Memory Location (WRITE) 15-15
 Write Transfer 6-14, 6-15

Z

zero wait state 9-11
 zero wait-state operation 6-30, 6-47

Freescale Semiconductor, Inc.

Introduction	1
Signal Description	2
ColdFire Core	3
Instruction Cache	4
SRAM	5
Bus Operation	6
DMA Controller Module	7
System Integration Module (SIM)	8
Chip Select Module	9
Parallel Port (General-Purpose I/O)	10
DRAM Controller	11
UART Modules	12
MBus Module	13
Timer Module	14
Debug Support	15
IEEE 1149.1 JTAG	16
Electrical Characteristics	17
Mechanical Characteristics	18
Appendix A: MCF5206e Memory Map	A
Appendix B: Porting from M68000	B

Freescale Semiconductor, Inc.

- 1** Introduction
- 2** Signal Description
- 3** ColdFire Core
- 4** Instruction Cache
- 5** SRAM
- 6** Bus Operation
- 7** DMA Controller Module
- 8** System Integration Module (SIM)
- 9** Chip Select Module
- 10** Parallel Port (General-Purpose I/O)
- 11** DRAM Controller
- 12** UART Modules
- 13** M-Bus Module
- 14** Timer Module
- 15** Debug Support
- 16** IEEE 1149.1 JTAG
- 17** Electrical Characteristics
- 18** Mechanical Characteristics
- A** Appendix A: MCF5206e Memory Map
- B** Appendix B: Porting from M68000