

ML4821

Power Factor Controller

Features

- Average current sensing for lowest possible harmonic distortion
- Average line compensation with brown-out control
- Precision buffered 5V reference
- 1A peak current totem-pole output drive
- Overvoltage comparator eliminates output “runaway” due to load removal
- Wide common mode range in current sense comparators for better noise immunity
- Large oscillator amplitude for better noise immunity
- Output driver internally limited to 17V
- “Sleep mode” shutdown input

General Description

The ML4821 provides complete control for a “boost” type power factor correction system using the average current sensing method. Special care has been taken in the design of the ML4821 to increase system noise immunity. The circuit includes a precision reference, gain modulator, average current error amplifier, output error amplifier, over-voltage protection comparator, shutdown logic, as well as a high current output. In addition, start-up is simplified by an under-voltage lockout circuit.

In a typical application, the ML4821 controls the AC input current by adjusting the pulse width of the output MOSFET. This modulates the line current so that its shape conforms to the shape of the input voltage. The reference for the current regulator is a product of the sinusoidal line voltage times the output of the error amplifier which is regulating the output DC voltage. Average line voltage compensation is provided in the gain modulator to ensure constant loop gain over a wide input voltage range. This compensation includes a special “brown-out” control which reduces output power below 90V RMS input.

Block Diagram

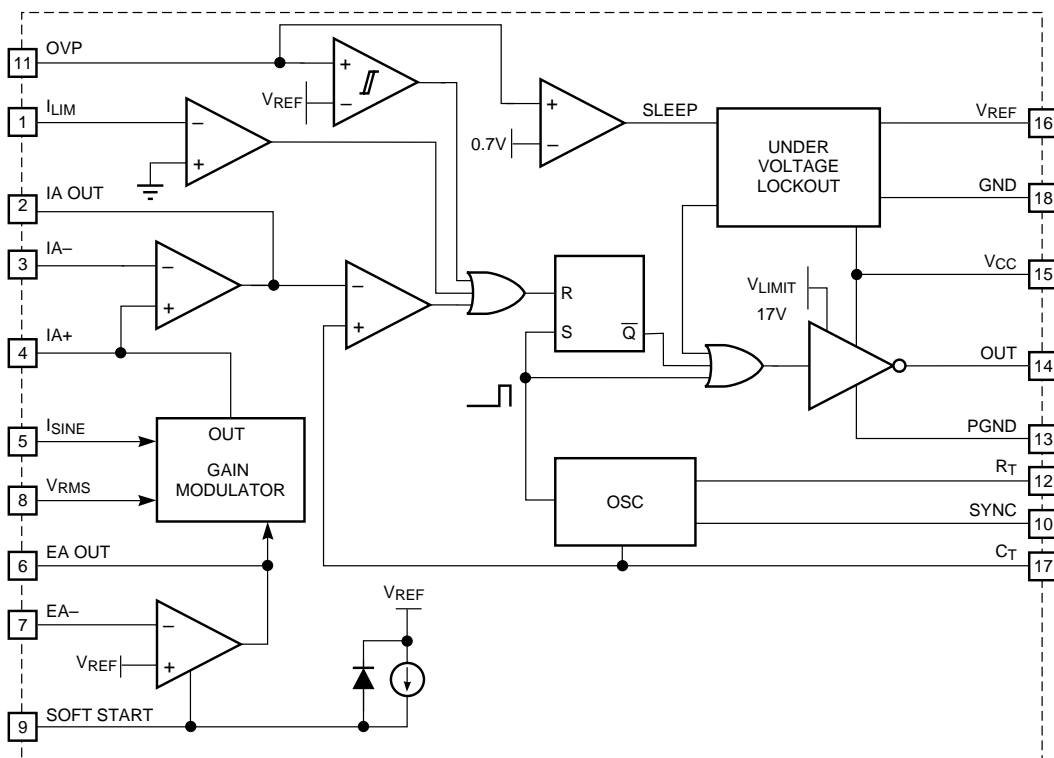

Pin Connection

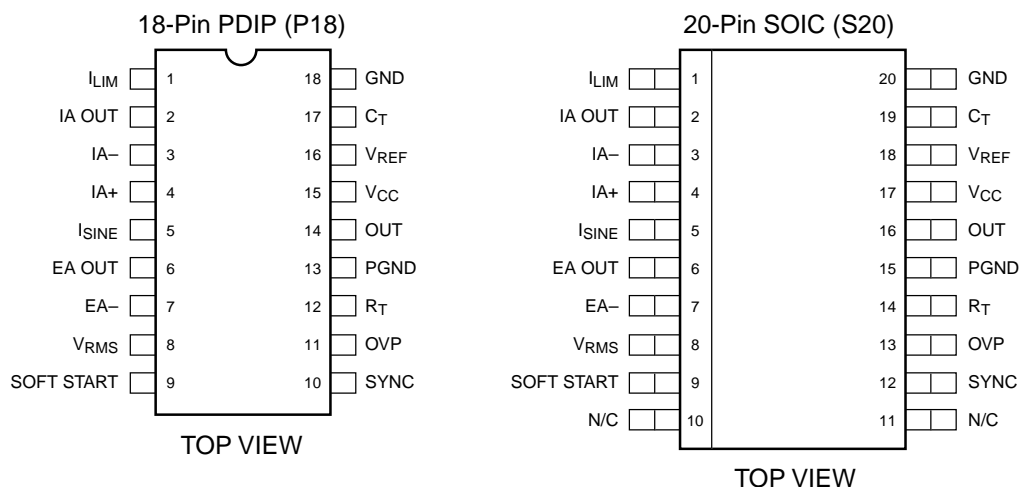

Pin Description

Pin Number		Name	Function
18-Pin DIP	20-Pin SOIC		
1	1	ILIM	Peak cycle-by-cycle current limit input
2	2	IA OUT	Output and compensation node of the average current error amplifier
3	3	IA-	Inverting input of the average current error amplifier
4	4	IA+	Non-Inverting input of the average current error amplifier and output of the gain modulator
5	5	ISINE	Gain modulator input
6	6	EA OUT	Output of output voltage error amplifier
7	7	INV	Inverting input to error amplifier
8	8	VRMS	Input for average line voltage compensation
9	9	SOFT START	Normally connected to soft start capacitor
10	12	SYNC	Oscillator synchronization input
11	13	OVP	Inhibits output pulses when the voltage at this pin exceeds 5V. Also, when the voltage at this pin is less than 0.7V, the IC goes into low current shut-down mode.
12	14	RT	Timing resistor for the oscillator
13	15	PWR GND	Return for the high current totem pole output
14	16	OUT	High current totem pole output
15	17	VCC	Positive supply for the IC
16	18	VREF	Buffered output for the 5V voltage reference
17	19	CT	Timing capacitor for the oscillator.
18	20	GND	Analog signal ground

Absolute maximum ratings

Absolute maximum ratings are those values beyond which the device could be permanently damaged. Absolute maximum ratings are stress ratings only and functional device operation is not implied.

Parameter	Min	Max	Units
Supply Current (I _{CC})		35	mA
OUT Current, Source or Sink		1.0	A
Output Energy (capacitive load per cycle)		5	μJ
ISINE Input Current		1.2	mA
EA OUT Source Current		50	mA
Oscillator Charge Current		2	mA
Input Voltage	GND -0.3V	5.5	V
Junction Temperature		150	°C
Storage Temperature Range	-65	150	°C
Lead Temperature (Soldering 10 sec.)		260	°C
Thermal Resistance (θ _{JA})			
Plastic DIP		75	°C/W
Plastic SOIC		95	°C/W

Operating Conditions

Temperature Range	Min	Max	Units
ML4821CX	0	70	°C

Electrical Characteristics

Unless otherwise specified, R_T = 6.2kΩ, C_T = 720pF, T_A = Operating Temperature Range, V_{CC} = 15V (Notes 1 & 2).

Parameter	Conditions	Min.	Typ.	Max.	Units
Oscillator					
Initial accuracy	T _A = 25°C	90	100	110	kHz
Voltage stability	12V < V _{CC} < 18V		1		%
Temperature stability			2		%
Total Variation	Line, Temperature	85		115	kHz
Ramp Valley to Peak		4.7	5.2	5.6	V
R _T Voltage		4.8	5.0	5.2	V
Discharge Current	C _T = 2V, R _T = Open	7.8	8.4	9.3	mA
SYNC Input Threshold		1.5	2.0	3.0	V
Reference					
Output Voltage	T _A = 25°C, I _O = 1mA	4.95	5.00	5.05	V
Line regulation	12V < V _{CC} < 24V		2	10	mV
Load regulation	1mA < I _O < 20mA		2	15	mV
Temperature stability			.4		%
Total Variation	line, load, temp	4.9		5.1	V
Output Noise Voltage	10Hz to 10kHz		50		μV
Long Term Stability	T _A = 125°C, 1000 hrs		5	25	mV
Short Circuit Current	V _{REF} = 0V	-30	-85	-180	mA

Electrical Characteristics (continued)Unless otherwise specified, $R_T = 6.2k\Omega$, $C_T = 720pF$, $T_A =$ Operating Temperature Range, $V_{CC} = 15V$ (Notes 1 & 2).

Parameter	Conditions	Min.	Typ.	Max.	Units
Voltage Error Amplifier					
Input Offset Voltage		0		-15	mV
Input Bias Current			-50	-800	nA
Open Loop Gain	$2 < EA\ OUT < 6V$	60	75		dB
PSRR	$12V < V_{CC} < 24V$	70	100		dB
Output Sink Current	$EA\ OUT = 4V, INV = 5.5V$	300	500		μA
Output Source Current	$EA\ OUT = 4.0V, INV = 4.8V$	-10	-30		mA
Output High Voltage	$IPIN6 = -5mA, VPIN7 = 4.8V$	7.0	7.5		V
Output Low Voltage	$IPIN6 = 0, EA- = 5.5V$		0	0.5	V
Unity Gain Bandwidth			1.0		MHz
Soft Start Charge Current	$VPIN9 = 4V$	-22	-38	-50	μA
Current Error Amplifier					
Input Offset Voltage		-5	0	5	mV
Input Bias Current			-0.15	-1	μA
Input Offset Current				400	nA
Open Loop Gain	$2 < EA\ OUT < 7V$	80	100		dB
PSRR	$12V < V_{CC} < 24V$	65	85		dB
Output Voltage Low	$I_{OL} = 300\mu A$		0	0.5	V
Output Voltage High	$I_{OH} = -10mA$	7.0	7.5		V
Input Common Mode Range		-0.3		2.5	V
Gain Modulator					
Gain	$V_{INV} = 4.8V, V_{RMS} = 0V$	0.75	1.2	1.3	
	$V_{INV} = 4.8V, V_{RMS} = 1.75V$	3.1	3.88	4.5	
	$V_{INV} = 4.8V, V_{RMS} = 2.6V$	1.25	1.75	2.15	
	$V_{INV} = 4.8V, V_{RMS} = 5.2V$	0.22	0.38	0.50	
Output Current	$V_{INV} = 5.2V, V_{RMS} = 5.2V$		-2	-4	μA
Output Current Limit	$V_{INV} = 4.8V, I_{SINE} = 500\mu A, V_{RMS} = 1.75V$	360	395	420	μA
ILIM Comparator					
Input Offset Voltage				+15	mV
Input Bias Current			-100	-200	μA
OVP Comparator					
Input Offset Voltage	Output Off	-25		5	mV
Hysteresis	Output On	85	105	130	mV
Input Bias Current			-0.3	-3	μA
Propagation Delay			150		ns
Shutdown Threshold		0.4	0.7	1.0	V
PWM Comparator					
Input Common Mode Range		0		8	V
Propagation Delay			150		ns

Electrical Characteristics (continued)

Unless otherwise specified, $R_T = 6.2k\Omega$, $C_T = 720pF$, $T_A =$ Operating Temperature Range, $V_{CC} = 15V$ (Notes 1 & 2).

Parameter	Conditions	Min.	Typ.	Max.	Units
Output					
Output Voltage Low	$I_{OUT} = 20mA$		0.1	0.4	V
	$I_{OUT} = 200mA$		1.6	2.4	V
Output Voltage High	$I_{OUT} = -20mA$	13	13.5		V
	$I_{OUT} = -200mA$	12	13.4		V
Output Voltage Low in UVLO	$I_{OUT} = -5mA$, $V_{CC} = 8V$		0.1	0.8	V
Output Rise/Fall Time	$C_L = 1000pF$		50		ns
Undervoltage Lockout					
Start-up Threshold		14.5		16.5	V
Shut-Down Threshold		8.5		11.0	V
VREF Good Threshold			4.4		V
Supply					
Supply Current	Start-up, $V_{CC} = 14V$, $T_A = 25^\circ C$ Operating, $T_A = 25^\circ C$		0.6	1.2	mA
			26	32	mA
Internal Shunt Zener Voltage	$I_{CC} = 35mA$	25	27	35	V

Notes:

- Limits are guaranteed by 100% testing, sampling or correlation with worst case test conditions.
- V_{CC} is raised above the start-up threshold first to activate the IC, then returned to 15V
- Gain Modulator gain is defined as:

$$\frac{I_{OUTIA+}}{I_{INEAOUT}}$$

Functional Description

Oscillator

The ML4821 oscillator charges the external capacitor connected to C_T with a current equal to $2.5/R_T$. When the capacitor voltage reaches the upper threshold, the comparator changes state and the capacitor discharges to the lower threshold through Q1.

The oscillator period can be described by the following relationship:

$$T_{OSC} = T_{RAMP} + T_{DISCHARGE}$$

where:

$$T_{RAMP} = C(Ramp\ Valley\ to\ Peak) \div (I_{RT}/2)$$

and:

$$T_{DISCHARGE} = C(Ramp\ Valley\ to\ Pk) \div (8.4mA - I_{RT}/2)$$

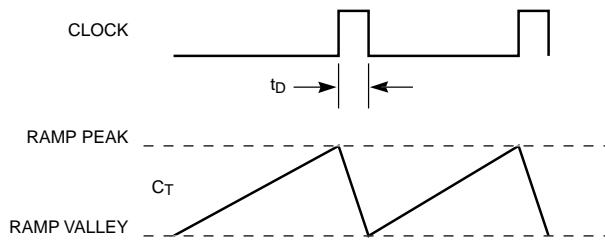

The ML4821 oscillator includes a SYNC input for synchronizing to an external frequency source. A positive pulse on this pin of 2V (typ) resets the oscillators comparator and initiates a discharge cycle for C_T . The R_T and C_T component values which set the ML4821 oscillator frequency should be selected to produce a lower frequency than the external frequency source.

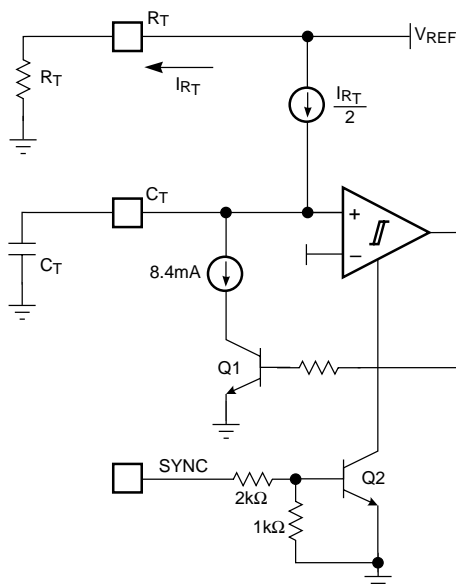

Figure 1. Oscillator Block Diagram

VOLTAGE and Current ERROR Amplifiers

The ML4821 voltage error amplifier is a high open loop gain, wide bandwidth amplifier with a class A output. The soft start circuit controls the input to this amplifier for closed loop soft start operation.

The current error amplifier (IA) is similar to the voltage error amplifier but is designed for very low offsets to allow the selection of a low value resistor for R_{SENSE} .

Output Driver Stage

The ML4821 Output Driver is a 1A peak output high speed totem pole circuit designed to quickly drive capacitive loads, such as power MOSFET gates. The driver circuit's output voltage is internally limited to 17V.

Gain Modulator

The ML4821 gain modulator responds linearly to current injected into the I_{SINE} pin, and in an inverse-square fashion to voltage on the V_{RMS} pin. At very low voltages on the V_{RMS} pin, the gain modulator enforces a power limit, or "brown-out protection", upon the overall PFC circuit (Figures 6 and 7). The rectified line input sine wave is converted to a current for the I_{SINE} input via a dropping resistor. In this way, most ground noise produces an insignificant effect on the reference to the PWM comparator. This gives the ML4821 a high degree of immunity to the disturbances common in high-power switching circuits.

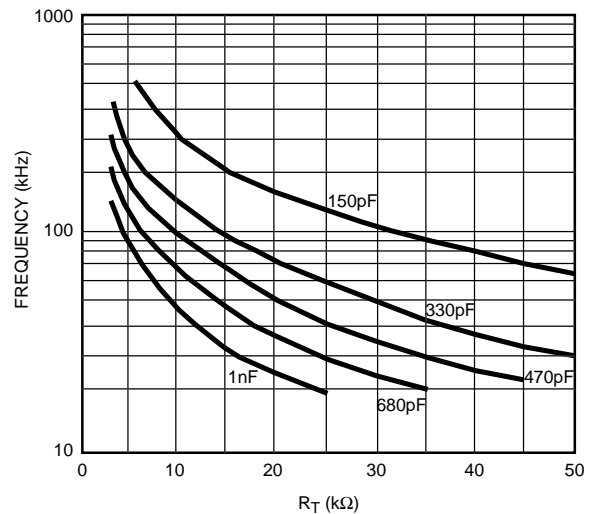

Figure 2. Oscillator Timing Resistance vs. Frequency

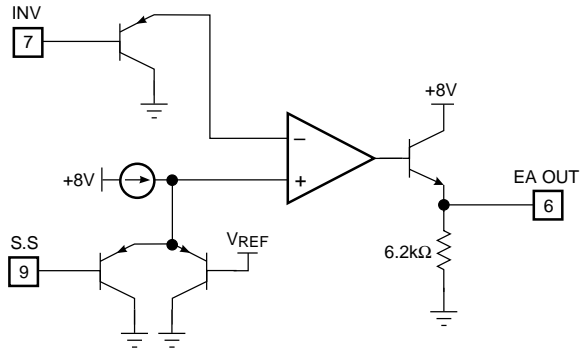

Figure 3. Error and Current Amplifier Configuration

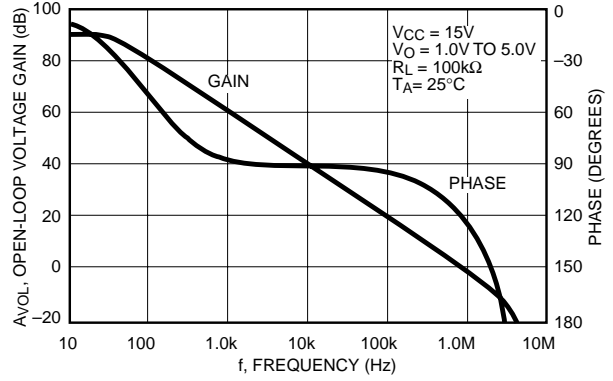

Figure 4. Error Amplifier Open-loop Gain and Phase vs. Frequency.

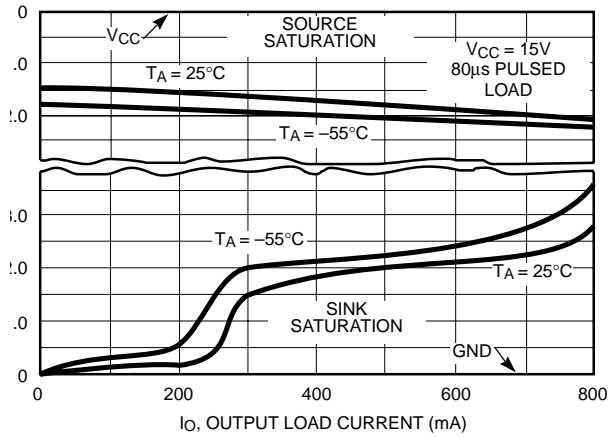

Figure 5. Output Saturation Voltage vs. Output Current.

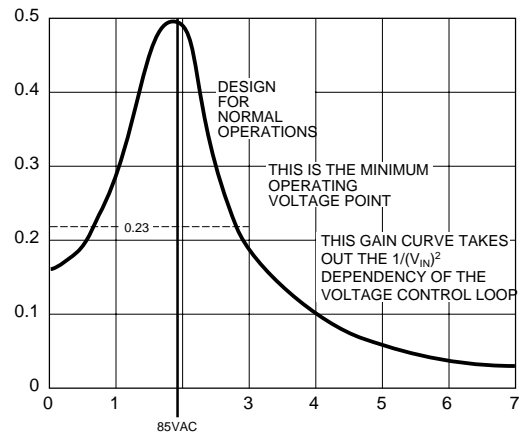

Figure 6. K-factor. Gain Modulator gain with respect to the voltage at VRMS.

Under Voltage Lockout, OVP and Current Limit

On power-up the ML4821 remains in the UVLO condition; output low and quiescent current low. The IC becomes operational when V_{CC} reaches 16V. When V_{CC} drops below 9V, the UVLO condition is imposed. During the UVLO condition, the V_{REF} pin is “off”, making it usable as a “flag” for starting up a down-stream PWM converter.

OVP, Shutdown, and IC Bias

When the input to the OVP comparator exceeds V_{REF} , the output of the ML4821 is inhibited. The OVP input also functions as a “sleep” input, putting the IC into the low quiescent UVLO state when the OVP pin is pulled below 0.7V.

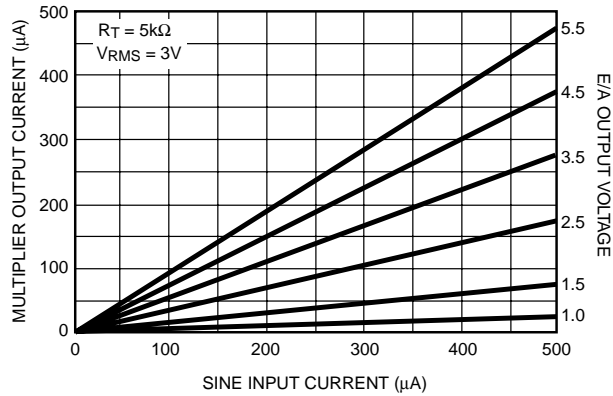

Figure 7. Gain Modulator Linearity.

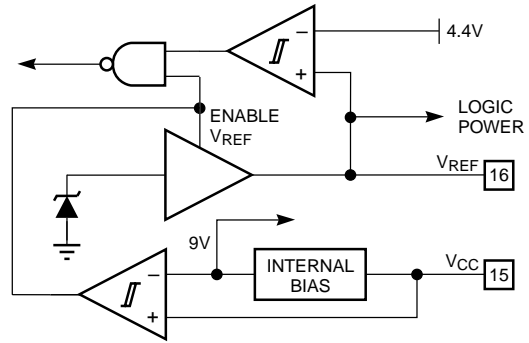

Figure 8. Under-Voltage Lockout Block Diagram.

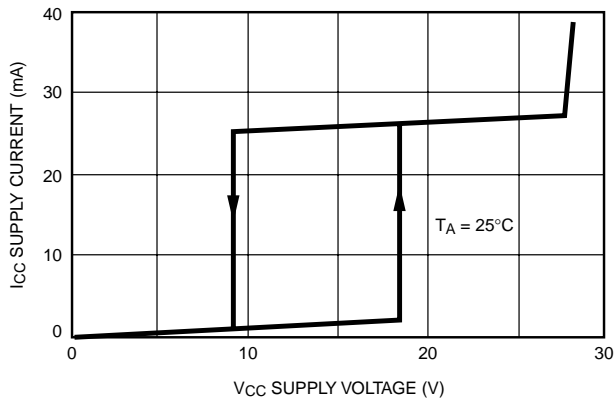

Figure 9. Total Supply Current vs. Supply Voltage.

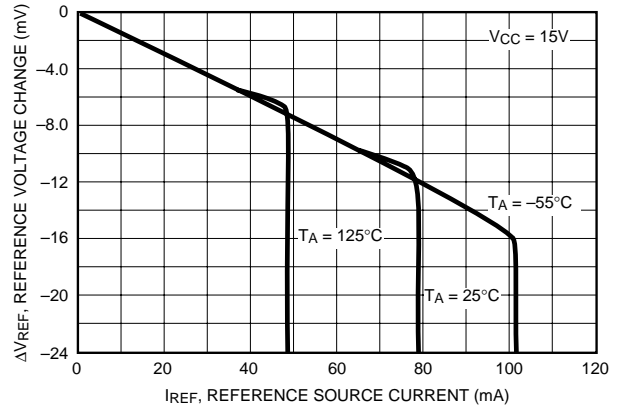

Figure 10. Reference Load Regulation.

Off-line Start-up and Bias Supply Generation

The circuit in Figure 11 supplies V_{CC} power to the ML4821. Start-up current is delivered via R10. The IC starts when V_{CC} reaches 15.5V. After that time running power is delivered through the tap on L1. The configuration shown delivers a voltage proportional to the PFC output bus voltage.

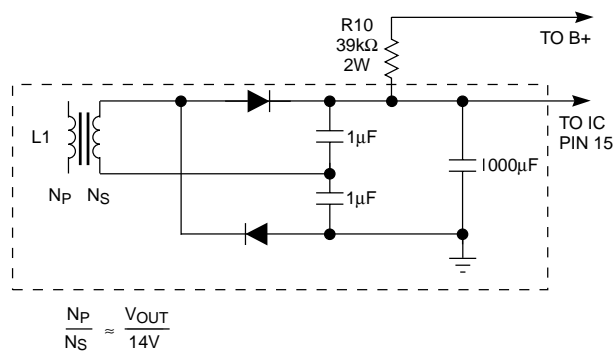
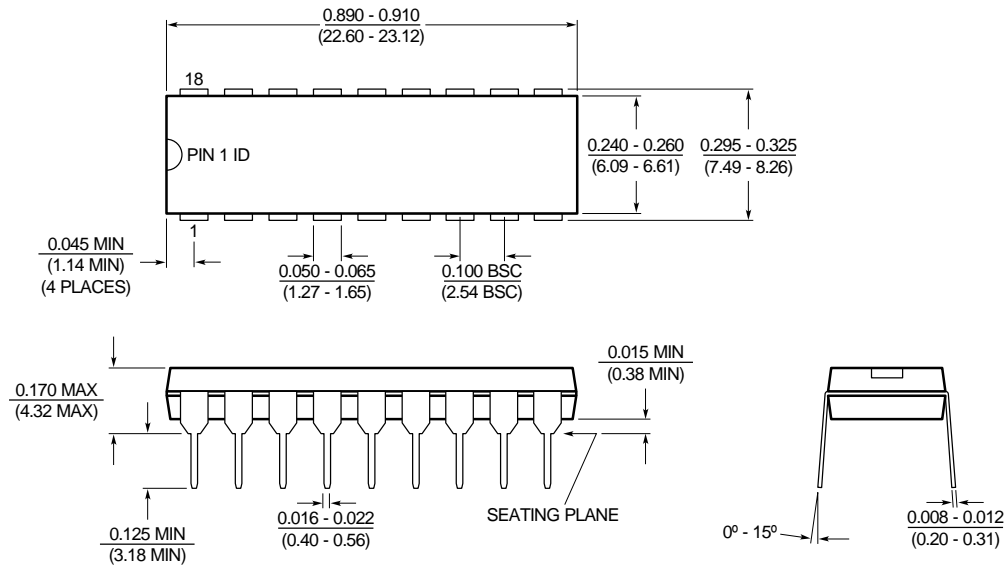

Figure 11. Bias and Start-up Circuit.

Mechanical Dimensions inches (millimeters)

Package: P18
18-Pin PDIP



Package: S20
20-Pin SOIC

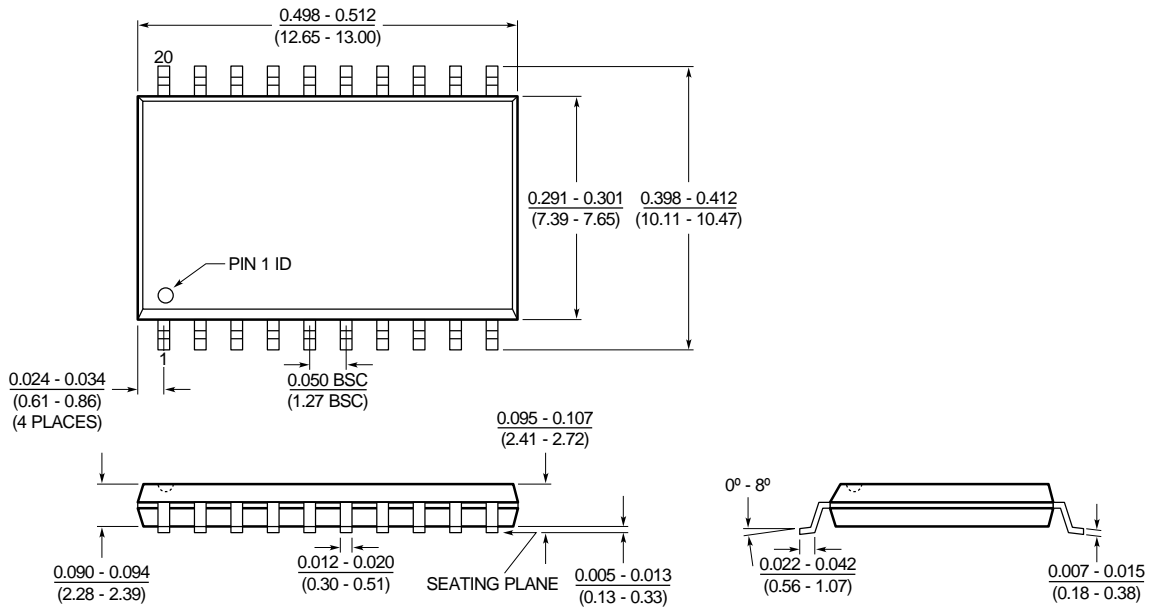

Ordering Information

Part Number	Temperature Range	Package
ML4821CP	0°C to 70°C	18-Pin PDIP (P18)
ML4821CS	0°C to 70°C	20-Pin SOIC (S20)

DISCLAIMER

FAIRCHILD SEMICONDUCTOR RESERVES THE RIGHT TO MAKE CHANGES WITHOUT FURTHER NOTICE TO ANY PRODUCTS HEREIN TO IMPROVE RELIABILITY, FUNCTION OR DESIGN. FAIRCHILD DOES NOT ASSUME ANY LIABILITY ARISING OUT OF THE APPLICATION OR USE OF ANY PRODUCT OR CIRCUIT DESCRIBED HEREIN; NEITHER DOES IT CONVEY ANY LICENSE UNDER ITS PATENT RIGHTS, NOR THE RIGHTS OF OTHERS.

LIFE SUPPORT POLICY

FAIRCHILD'S PRODUCTS ARE NOT AUTHORIZED FOR USE AS CRITICAL COMPONENTS IN LIFE SUPPORT DEVICES OR SYSTEMS WITHOUT THE EXPRESS WRITTEN APPROVAL OF THE PRESIDENT OF FAIRCHILD SEMICONDUCTOR CORPORATION. As used herein:

1. Life support devices or systems are devices or systems which, (a) are intended for surgical implant into the body, or (b) support or sustain life, and (c) whose failure to perform when properly used in accordance with instructions for use provided in the labeling, can be reasonably expected to result in a significant injury of the user.
2. A critical component in any component of a life support device or system whose failure to perform can be reasonably expected to cause the failure of the life support device or system, or to affect its safety or effectiveness.