

Surface Mount Fuses Type 172876

quick-acting F

directly solderable on printed circuit boards or pluggable into surface mount fuseholder

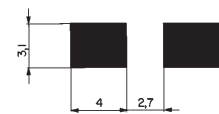
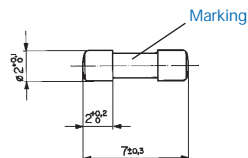
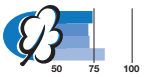

Solder pad

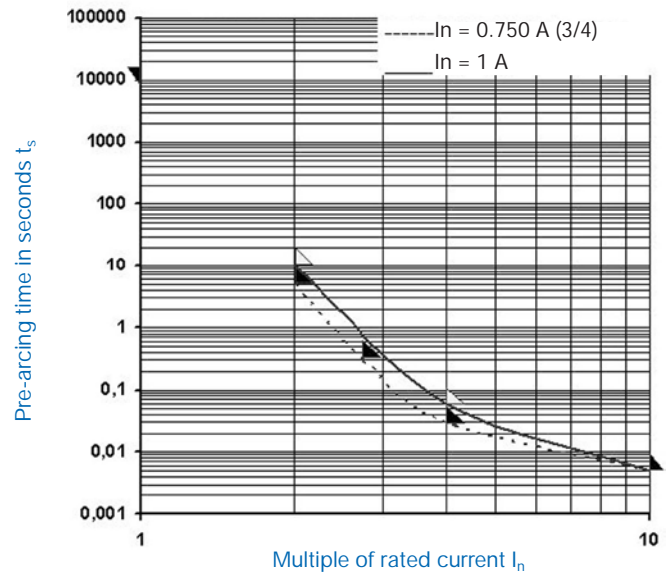

Standards

UL 248-14

Approvals



Pre-arcing time/current characteristic (at T_a 23 °C)

Rated current I _n	n · I _n				
	1 · I _n	2 · I _n	2,75 · I _n	4 · I _n	10 · I _n
< 750 mA	t ≥ 4 h	t ≤ 5 s	t ≤ 300 ms	t ≤ 30 ms	t ≤ 5 ms
≥ 1 A	t ≥ 4 h	t ≤ 10 s		t ≤ 60 ms	t ≤ 5 ms

Order No.	Rated current I _n Rated voltage U _n	Breaking capacity	Voltage drop		Sustained power dissipation	Pre-arcing I ² t	Approvals UL CSA
			at I _n max. mV	at 1 · I _n max. mW	at 10 · I _n A ² s		
7010.9750.XX	63 mA / 125 V	300 A / 125 V AC/DC cos φ = 1 L/R = 1 ms	590	37	0,00022	• •	
7010.9760.XX	125 mA / 125 V		640	80	0,0024		
7010.9770.XX	250 mA / 125 V		275	69	0,0061		
7010.9780.XX	375 mA / 125 V		215	81	0,012		
7010.9790.XX	500 mA / 125 V		205	103	0,046		
7010.9800.XX	750 mA / 125 V		190	143	0,09		
7010.9810.XX	1 A / 125 V		180	180	0,11		
7010.9820.XX	1,5 A / 125 V		185	278	0,25		
7010.9830.XX	2 A / 125 V		160	320	0,72		
7010.9840.XX	2,5 A / 125 V		160	400	0,91		
7010.9850.XX	3 A / 125 V		155	465	1,3		
7010.9860.XX	3,5 A / 125 V		145	510	1,7		
7010.9870.XX	4 A / 125 V		140	560	2,6		
7010.9880.XX	5 A / 125 V		125	625	4		
7010.9890.XX	7 A / 125 V	120	840	8,5			
7010.9892.XX	10 A / 65 V	300 A / 65 V AC/DC cos φ = 1 L/R = 1 ms	110	1100	31		
7010.9894.XX	12 A / 65 V		115	1380	48		
7010.9896.XX	15 A / 65 V		105	1575	92		

.XX Packaging index

Additional technical data and packaging see page 54

FUSES

Non resettable fuses

172876, MSB, MKF, MKT

Additional technical data

Ambient temperature max. T_a	- 55 °C ÷ + 85 °C
Solderability; Reflow-(infra-red and vapour phase) and wave soldering	235 °C / 2 sec. IEC 60068-2-58 / test Td
Soldering heat resistance	260 °C / 10 sec. IEC 60068-2-58 / test Td
Materials: Housing Terminals	Ceramics Brass, tin-plated
Net weight %	172876, MSB = 7 g for 100 pieces MKf, MKT = 14,5 g for 100 pieces

Packaging

Types 172876 and MSB

Tube or tape	
Tube of 100 pieces	7010.XXXX.63
Taped and reeled 1500 pieces	7010.XXXX.57
Taped and reeled 5000 pieces	7010.XXXX.59

Types MKF and MKT

Bag or tape	
Bag of 100 pieces	7010.XXXX.03
Taped and reeled 1500 pieces	7010.XXXX.57

Blisertape and reel

according to IEC 60286-3

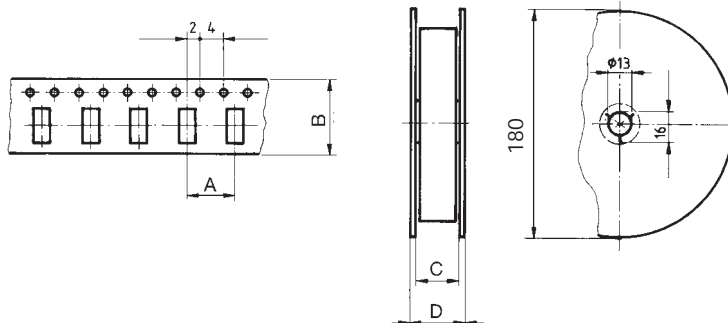

Types	Dimensions in mm			
	A	B	C (max.)	D (max.)
172876	4	12	12,4	18,4
MSB				
MKF				
MKT				



Suitable surface mount fuseholder see page 177