

# F<sup>2</sup>MC-16LX FAMILY EVALUATION BOARD ADA-91270-90340-100PFV V1.1

## USER GUIDE

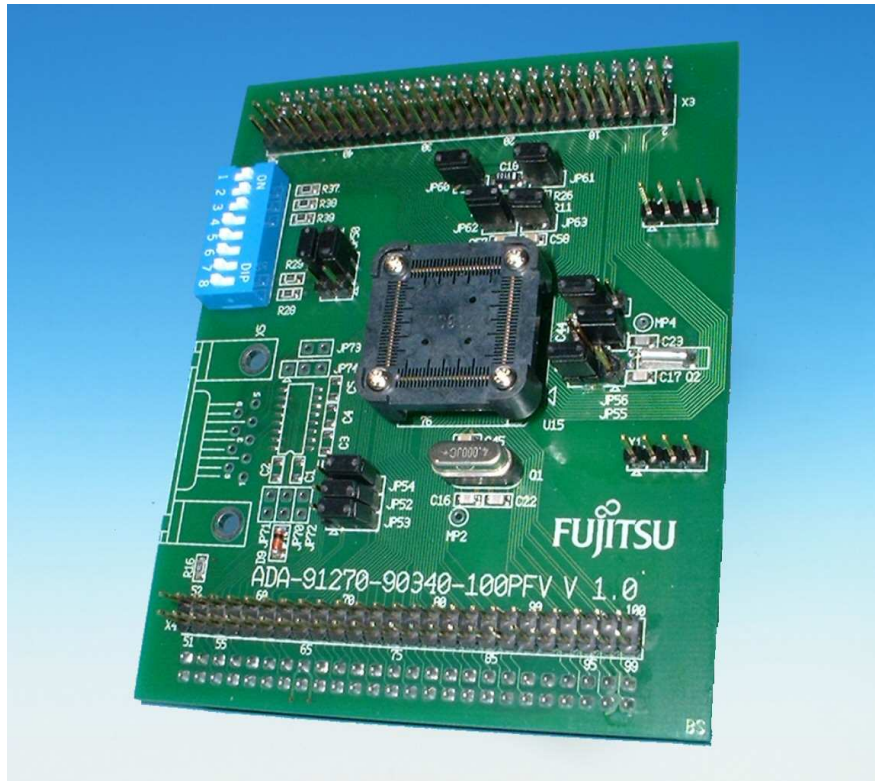

## Revision History

Date	Issue
2006-10-18	V1.0, HW/PH: First Release
2006-11-27	V1.1, CSC: Added Socket Note
2007-03-02	V1.2 Recycling Note added
2008-09-04	V1.3, MSc: China-RoHS regulation added

This document contains 25 pages.

## Warranty and Disclaimer

To the maximum extent permitted by applicable law, Fujitsu Microelectronics Europe GmbH restricts its warranties and its liability for **the ADA-91270-90340-100PFV Board and all its deliverables** (eg. software include or header files, application examples, target boards, evaluation boards, engineering samples of IC's etc.), its performance and any consequential damages, on the use of the Product in accordance with (i) the terms of the License Agreement and the Sale and Purchase Agreement under which agreements the Product has been delivered, (ii) the technical descriptions and (iii) all accompanying written materials. In addition, to the maximum extent permitted by applicable law, Fujitsu Microelectronics Europe GmbH disclaims all warranties and liabilities for the performance of the Product and any consequential damages in cases of unauthorised decompiling and/or reverse engineering and/or disassembling. **Note, the ADA-91270-90340-100PFV Board and all its deliverables are intended and must only be used in an evaluation laboratory environment.**

1. Fujitsu Microelectronics Europe GmbH warrants that the Product will perform substantially in accordance with the accompanying written materials for a period of 90 days from the date of receipt by the customer. Concerning the hardware components of the Product, Fujitsu Microelectronics Europe GmbH warrants that the Product will be free from defects in material and workmanship under use and service as specified in the accompanying written materials for a duration of 1 year from the date of receipt by the customer.
2. Should a Product turn out to be defect, Fujitsu Microelectronics Europe GmbH's entire liability and the customer's exclusive remedy shall be, at Fujitsu Microelectronics Europe GmbH's sole discretion, either return of the purchase price and the license fee, or replacement of the Product or parts thereof, if the Product is returned to Fujitsu Microelectronics Europe GmbH in original packing and without further defects resulting from the customer's use or the transport. However, this warranty is excluded if the defect has resulted from an accident not attributable to Fujitsu Microelectronics Europe GmbH, or abuse or misapplication attributable to the customer or any other third party not relating to Fujitsu Microelectronics Europe GmbH.
3. To the maximum extent permitted by applicable law Fujitsu Microelectronics Europe GmbH disclaims all other warranties, whether expressed or implied, in particular, but not limited to, warranties of merchantability and fitness for a particular purpose for which the Product is not designated.
4. To the maximum extent permitted by applicable law, Fujitsu Microelectronics Europe GmbH's and its supplier's liability are restricted to intention and gross negligence.

### **NO LIABILITY FOR CONSEQUENTIAL DAMAGES**

**To the maximum extent permitted by applicable law, in no event shall Fujitsu Microelectronics Europe GmbH and its suppliers be liable for any damages whatsoever (including but without limitation, consequential and/or indirect damages for personal injury, assets of substantial value, loss of profits, interruption of business operation, loss of information, or any other monetary or pecuniary loss) arising from the use of the Product.**

Should one of the above stipulations be or become invalid and/or unenforceable, the remaining stipulations shall stay in full effect

# 1 Contents

<b>REVISION HISTORY .....</b>	<b>2</b>
<b>WARRANTY AND DISCLAIMER .....</b>	<b>3</b>
<b>1 CONTENTS.....</b>	<b>4</b>
<b>2 OVERVIEW.....</b>	<b>5</b>
2.1 Abstract.....	5
2.2 Features of adapter board ADA-91270-90340-100PFV .....	5
2.3 Features supported by base-board FLASH-CAN-100P-340 .....	5
<b>3 INSTALLATION .....</b>	<b>6</b>
3.1 MB90340 / MB96340 Series.....	7
3.2 MB91270 Series.....	8
3.3 Jumper settings of FLASH-CAN-100P-340.....	9
<b>4 JUMPERS AND SWITCHES.....</b>	<b>11</b>
4.1 Operating-Mode (S2).....	11
4.2 Analogue Power Supply Voltage (JP: 60, 61, 62, 63) .....	12
4.3 Subclock (JP: 55, 56) .....	13
4.4 UART"A" (JP: 52, 53, 54) .....	14
<b>5 PROGRAMMING THE INTERNAL FLASH.....</b>	<b>15</b>
5.1 Asynchronous Mode.....	15
<b>6 CONNECTORS.....</b>	<b>17</b>
6.1 Edge connector (X3, X4) .....	17
<b>7 SILK-PLOT OF THE BOARD .....</b>	<b>18</b>
<b>8 NOTES ON USING THE ADA-91270-90340-100PFV V1.1.....</b>	<b>19</b>
8.1 Stand-alone mode .....	19
8.2 PCB History.....	19
<b>9 RELATED PRODUCTS .....</b>	<b>20</b>
<b>10 INFORMATION IN THE WWW.....</b>	<b>21</b>

## 2 Overview

### 2.1 Abstract

The ADA-91270-90340-100PFV is an adapter board that can be used together with the evaluation board FLASH-CAN-100P-340 or as a stand-alone system with some limitations. The ADA-91270-90340-100PFV supports devices of the 16-Bit MB90340 and MB96340 Series and 32-Bit MB91270 Series with LQFP package PFV/M05/M20.

It can be used stand alone for software development and testing of with Flash-devices or as a target board to work with the emulator system.

The board allows the designer immediately to start with the software development before his own final target system is available.

### 2.2 Features of adapter board ADA-91270-90340-100PFV

- ▶ Supports the following series in FPT-100P-M05/FPT-100P-M20 package:
  - ▶ MB90340 Series: MB90F34x PFV
  - ▶ MB96340 Series: MB96F34x PFV
  - ▶ MB91270 Series: MB91F272x PFV
- ▶ All resources available for evaluation
- ▶ All pins routed to connectors
- ▶ 4 MHz main-crystal, 32kHz subclock-crystal (selectable by jumpers)
- ▶ Run- / Program-Mode Selector
- ▶ One UART interface (optional)

### 2.3 Features supported by base-board FLASH-CAN-100P-340

- ▶ 9-12V unregulated external DC power supply usable
- ▶ 5V internal power supply, Power-LED
- ▶ In-Circuit serial Flash programming
- ▶ Two UART interfaces
- ▶ Two LIN interfaces
- ▶ Two High-Speed CAN Transceivers
- ▶ 8 User LEDs, optional: alphanumeric standard LC-Display connectable instead of LEDs
- ▶ Reset-Button, Reset-LED
- ▶ Up to 5 User-buttons
- ▶ 96 pin VG connector

The adapter board will be delivered with the MB91F272WPFV (dual clock version).

This microcontroller contains a 'burn-in'-boot loader for programming the flash.

**This board must only be used for test applications  
in an evaluation laboratory environment.**

### 3 Installation

Remove carefully the board from the shipping carton and check for any damages.

Make the correct jumper setting for the related device (MB90340 Series / MB96340 Series / MB91270 Series).

The adapter board will be delivered with the MB91F272PFV microcontroller.

Before mounting the adapter on the FLASH-CAN-100P-340 remove the microcontroller and check the correct jumper setting of the evaluation board. For details about the FLASH-CAN-100P-340 evaluation board please see the user guide ug-900003.

**Note:**

**Some customers experience connectivity problems when connecting the MCU into the socket adapter. Only the small red screwdriver available in your box should be used to connect the cover (HQPACK) onto the socket (NQPACK).**

**If the four screws are not tightening equally, then it may cause a poor contact.**

**Do not screw the cover too tight (max 0.054 Nm). If you have connectivity problems then please loosen the screws and tighten again the screws equally.**

**Do not clean NQPACK, YQPACK, and YQSOCKET with steam. Cleaning material will contaminate inside of connector.**

### 3.1 MB90340 / MB96340 Series

The following default jumper setting of ADA-91270-90340-100PFV reflects a dual-clock device of MB90340 / MB96340 Series. For details please refer to chapter 4.

Jumper	Description / Function	Type	Default	
			MB90340	MB96340
JP50	P00/P10	Jumper 3 pol	1-2	
JP51	P01/P11	Jumper 3 pol	1-2	
JP52	SOT0/SOT1	Jumper 2 pol	1-2	
JP53	SIN0/SIN1	Jumper 2 pol	1-2	
JP54	SCK0/SCK1	Jumper 2 pol	1-2	
JP55	Subclock (X0A)	Jumper 4 pol	SUB	
JP56	Subclock (X1A)	Jumper 3 pol	1-2	
JP57	C-Pin	Jumper 3 pol	1-2	
JP60	AVSS	Jumper 2 pol	Closed	
JP61	AVCC	Jumper 2 pol	Closed	
JP62	AVRL	Jumper 2 pol	Closed	
JP63	AVRH	Jumper 2 pol	Closed	
JP70	Optional: UTXD	Jumper 2 pol	Open	
JP71	Optional: URXD	Jumper 2 pol	Open	
JP72	Optional: URST	Jumper 2 pol	Open	
JP73	Optional: RTS-CTS	Jumper 2 pol	Open	
JP74	Optional: URST	Jumper 3 pol	Open	

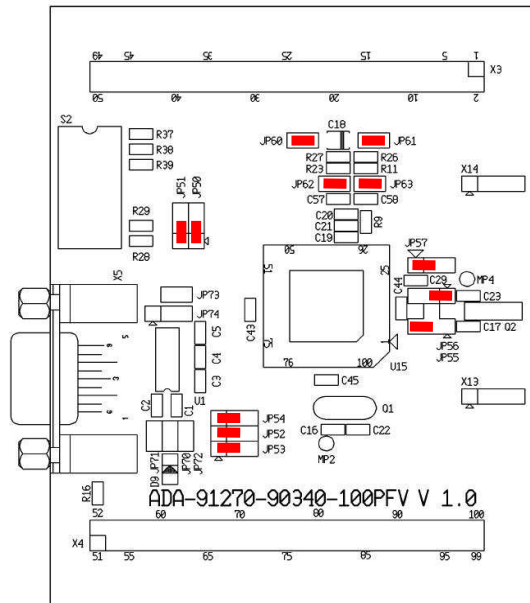

### 3.2 MB91270 Series

The following default jumper setting of ADA-91270-90340-100PFV reflects a dual-clock device of MB91270 Series. For details please refer to chapter 4.

Jumper	Description / Function	Type	Default MB91270
JP50	P00/P10	Jumper 3 pol	2-3
JP51	P01/P11	Jumper 3 pol	2-3
JP52	SOT0/SOT1	Jumper 2 pol	2-3
JP53	SIN0/SIN1	Jumper 2 pol	2-3
JP54	SCK0/SCK1	Jumper 2 pol	2-3
JP55	Subclock (X0A)	Jumper 4 pol	SUB
JP56	Subclock (X1A)	Jumper 3 pol	1-2
JP57	C-Pin	Jumper 3 pol	1-2
JP60	AVSS	Jumper 2 pol	Closed
JP61	AVCC	Jumper 2 pol	Closed
JP62	AVRL	Jumper 2 pol	Closed
JP63	AVRH	Jumper 2 pol	Closed
JP70	Optional: UTXD	Jumper 2 pol	Open
JP71	Optional: URXD	Jumper 2 pol	Open
JP72	Optional: URST	Jumper 2 pol	Open
JP73	Optional: RTS-CTS	Jumper 2 pol	Open
JP74	Optional: URST	Jumper 3 pol	Open

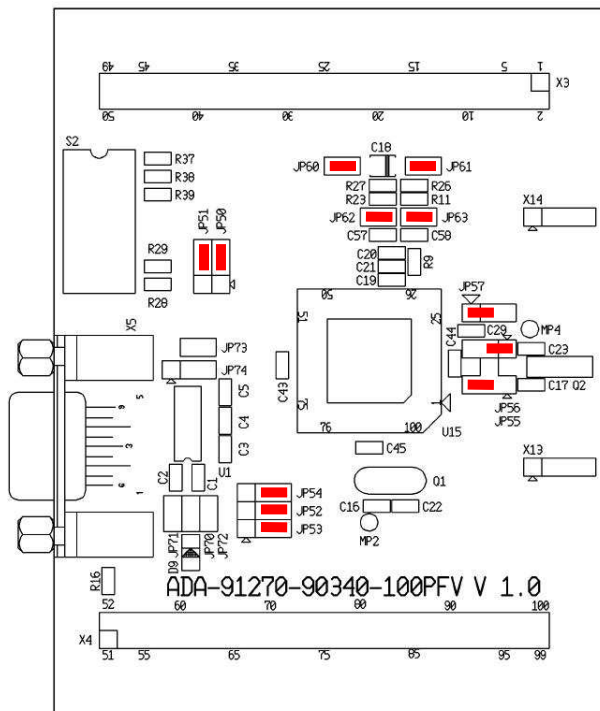



### 3.3 Jumper settings of FLASH-CAN-100P-340

The following jumper setting should be chosen if the FLASH-CAN-100P-340 V1.1 board is used together with ADA-91270-90340-100PFV:

Jumper	Description / Function	Type	Default ADA-91270- 90340-100PFV	Coordinates
JP1a	UART A (TXD) / UART0(MB90340)	Jumper 2 pol	Closed	D14
JP1b	UART A (TXD) / UART0(MB90800) / SIO4(MB90945)	Jumper 2 pol	Open	D14
JP1c	UART A (TXD) / UART0(MB90945)	Jumper 2 pol	Open	D14
JP2a	UART A (RXD) / UART0(MB90340)	Jumper 2 pol	Closed	EF9
JP2b	UART A (RXD) / UART0(MB90800) / SIO4(MB90945)	Jumper 2 pol	Open	EF9
JP2c	UART A (RXD) / UART0(MB90945)	Jumper 2 pol	Open	EF10
JP3	DTR/RTS A	Jumper 3 pol	Open	D4
JP4	RESET UART A/B	Jumper 3 pol	Open	E10
JP5	DTR/RTS B	Jumper 3 pol	Open	D8
JP6a	UART B (RXD) / UART2(MB90340)	Jumper 2 pol	Closed	EF12
JP6b	UART B (RXD) / UART1(MB90800)	Jumper 2 pol	Open	EF12
JP6c	UART B (RXD) / UART3(MB90945)	Jumper 2 pol	Open	EF13
JP8a	UART B (TXD) / UART2(MB90340)	Jumper 2 pol	Closed	EF11
JP8b	UART B (TXD) / UART1(MB90800)	Jumper 2 pol	Open	EF11
JP8c	UART B (TXD) / UART3(MB90945)	Jumper 2 pol	Open	EF12
JP7	Reset 3V3	Jumper 2 pol	Open	E8
JP9	LIN B enable	Jumper 2 pol	Open	G13
JP10	LIN B Master-Mode	Jumper 2 pol	Open	E3
JP11	AVcc	Jumper 2 pol	Closed	K21
JP12	SW1	Jumper 2 pol	Closed	G9
JP13	AVcc=AVRH	Jumper 2 pol	Closed	J21
JP14	SW2	Jumper 2 pol	Closed	G9
JP15	AVss	Jumper 2 pol	Closed	K19
JP16	SW3	Jumper 2 pol	90340: Closed 91270: Open	G9
JP17	LIN A enable	Jumper 2 pol	Open	H13
JP18	LIN A Master-Mode	Jumper 2 pol	Open	H3
JP19	AVss=AVRL	Jumper 2 pol	Closed	J20
JP20	SW4	Jumper 2 pol	Closed	F9
JP21a	LIN A (RXD) / LINUART1(90340)	Jumper 2 pol	Open	H13
JP21c	LIN A (RXD) / LINUART3(90945)	Jumper 2 pol	Open	H13
JP22a	LIN A (TXD) / LINUART1(90340)	Jumper 2 pol	Open	H13
JP22c	LIN A (TXD) / LINUART3(90945)	Jumper 2 pol	Open	H13
JP23	SW5	Jumper 2 pol	Closed	F9
JP24	RESET	Jumper 2 pol	Closed	E8
JP25	CAN A (TXD) / CAN0(MB90340)	Jumper 2 pol	Closed	J13
JP26	CAN A (RXD) / CAN0(MB90340)	Jumper 2 pol	Closed	J13
JP27a	CAN B (TXD) / CAN1(MB90340)	Jumper 2 pol	Open	J13
JP27c	CAN B (TXD) / CAN1(MB90945)	Jumper 2 pol	Open	J13
JP28a	CAN B (TXD) / CAN1(MB90340)	Jumper 2 pol	Open	K13
JP28c	CAN B (RXD) / CAN1(MB90945)	Jumper 2 pol	Open	K13
JP29	int/ext VCC	Jumper 3 pol	1-2	J17
JP30	5V/3V3	Jumper 2 pol	Open	L15
JP31	RTS-CTS A	Jumper 2 pol	Closed	D4
JP32	RTS-CTS B	Jumper 2 pol	Closed	D8
JP33	C-Pin to MCU VCC	sold-Jumper	Open	H22
JP34	MCU VCC	Jumper 2pol	Closed	J17
JP35	DTR / DTRx	Jumper 3 pol	Open	F11
JP36	X0A select	Jumper 4 pol	1-4	G22
JP37	X1A select	Jumper 3 pol	1-2	G22
JP38	LIN B (RXD) / LINUART3(90340)	Jumper 2 pol	Open	F12
JP39	LIN B (TXD) / LINUART3(90340)	Jumper 2 pol	Open	F12
JP40	C-Pin	Jumper 2 pol	Closed	GH22
JP41	P00/P65	Jumper 3 pol	1-2	E17
JP42	P01/P66	Jumper 3 pol	1-2	E17
JP43a	SCK0(MB90340)	Jumper 2 pol	Closed	D16
JP43b	SCK0(MB90800) / SCK4(MB90945)	Jumper 2 pol	Open	D16
JP44	SIN A	Jumper 2 pol	Closed	EF9

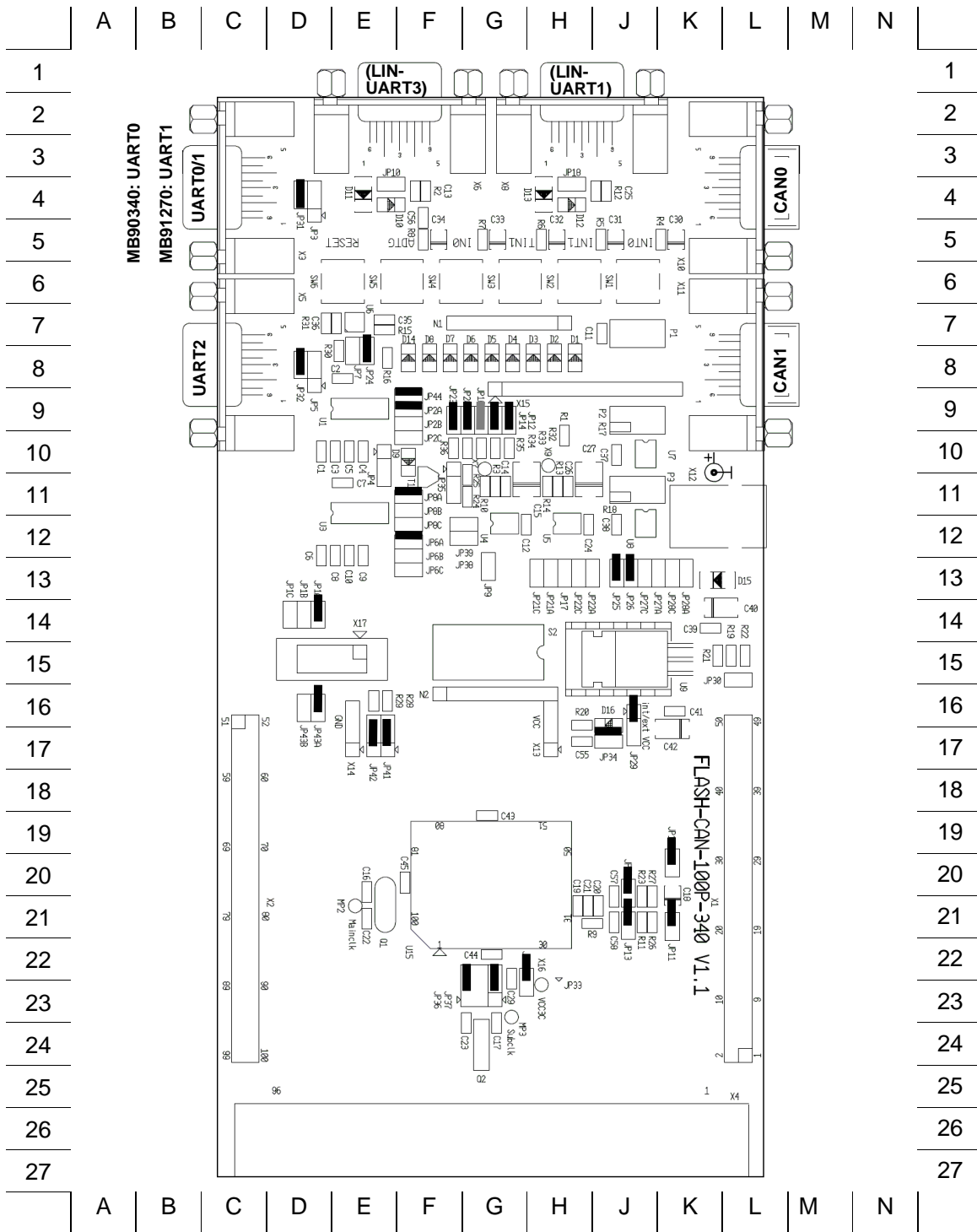

Please see the user guide ug-900003 for a detailed description of the FLASH-CAN100P-340 evaluation board.

## 4 Jumpers and Switches

This chapter describes all jumpers and switches that can be modified on the adapter board. The default setting (MB91270 Series) is shown with a grey shaded area. All jumpers and switches are named directly on the board, so it is very easy to set the jumpers according to the features.

### 4.1 Operating-Mode (S2)

The DIP-switch S2 is used to set the operating mode of the  $\mu$ C. Ensure that the mode pin settings correspond to the operation-mode of the application. For more detailed information please check the Hardware-Manual of the microcontroller.

DIP switch	Setting	Logical value
S2/1 (MD0)	ON (closed)	0 (low)
	OFF (open)	1 (high)
S2/2 (MD1)	ON (closed)	0 (low)
	OFF (open)	1 (high)
S2/3 (MD2)	ON (closed)	0 (low)
	OFF (open)	1 (high)
S2/4-6	not connected (OFF)	
S2/7 (P01/P11*)	ON (closed)	1 (high)
	OFF (open)	0 (low) * <sub>1</sub>
S2/8 (P00/P11*)	ON (closed)	1 (high)
	OFF (open)	0 (low) * <sub>1</sub>

\*<sub>1</sub>Note: The low-level for serial programming is reached by the pull-down resistors R28 and R29 that are enabled by the jumpers JP50 and JP51. Please refer to chapter 5 (Programming the internal Flash) for more details about the operation mode.

#### 4.1.1 MB90340 / MB96340 Series

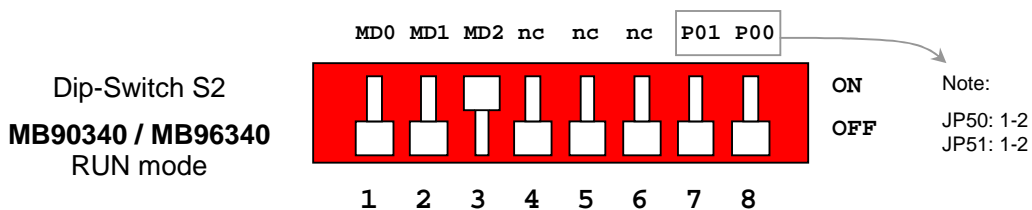

#### 4.1.2 MB91270 Series

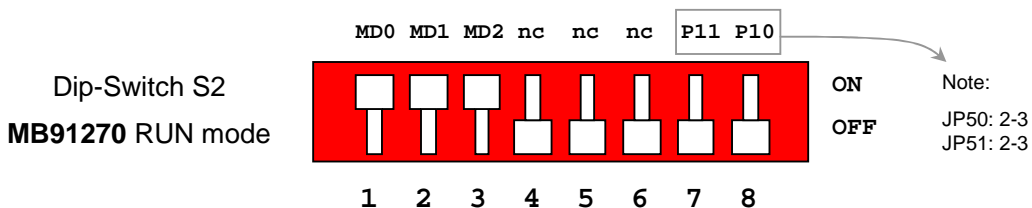

## 4.2 Analogue Power Supply Voltage (JP: 60, 61, 62, 63)

The power supply as well as the positive reference voltage for the A/D-converter can be provided internally or externally.

**JP60, JP61** connect power supply voltages (AVcc and AVss)

**JP62, JP63** connect reference voltages (AVRH to AVcc, ARRL to AVss)

Jumper	Setting	Description
JP60 (AVss)	ON (closed)	AVss is connected to GND
	OFF (open)	AVss is disconnected from GND
JP61 (AVcc)	ON (closed)	AVcc is connected to Vcc
	OFF (open)	AVcc is disconnected from Vcc
JP62 (AVRL)	ON (closed)	AVRL is connected to AVss
	OFF (open)	AVRL defined by resistor network <sup>*1</sup>
JP63 (AVRH)	ON (closed)	AVRH is connected to AVcc
	OFF (open)	AVRH defined by resistor network <sup>*1</sup>

<sup>\*1</sup>By default the resistor network (R11, R23 and R26, R27) is not mounted on the board

Default: JP60, JP61, JP62 and JP63 are closed

By default, the A/D-converter supply and reference voltage is same as the microcontroller supply voltage.

### **Note:**

If JP60 and J61 are open, the user has to supply an adequate analogue voltage supply (AVcc and AVss) to the A/D-converter.

If JP63 is open, the resistors R11 and R23 define AVRH.

If JP62 is open, the resistors R26 and R27 define AVRL.

By default the resistor network (R11, R23 and R26, R27) is not mounted on the board.

### 4.3 Subclock (JP: 55, 56)

Some devices support a 32 kHz subclock (X0A, X1A), other devices do not support a subclock but will offer additional port-pins (e.g. P40, P41) instead.

Please check the related datasheet.

Pin-out JP55:

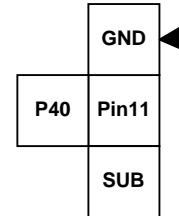

**JP55:** defines usage of microcontroller pin 11 (X0A/P40)

**JP56:** defines usage of microcontroller pin 12 (X1A/P41)

Jumper	Setting	Description
JP55 (X0A/P40)	SUB - Pin11	Pin 11 is connected to the 32 kHz Subclock (X0A)
	P40 - Pin11	Pin 11 is used as P40 and is connected to X3-11
	GND - Pin11	Pin 11 is connected to GND (in case that subclock-device is used, but no 32kHz crystal is connected)
JP56 (X1A/P41)	1-2	Pin 12 is connected to the 32kHz Subclock (X1A)
	2-3	Pin 12 is used as P41 and is connected to X3-12

Default: JP55: 1-4, JP56: 1-2

By default, the 32kHz-subclock-crystal is connected to the microcontroller.

#### 4.4 UART“A” (JP: 52, 53, 54)

Because MB90340, MB96340, and MB91270 Series uses different UARTs for the burn-in bootloader the right UART can be connected to UART “A” and the programming socket X17 for synchronous programming of the FLASH-CAN-100P-340 evaluation board:

MB90340 and MB96340 Series use UART0 for in circuit programming.

MB91270 Series uses UART1 for in circuit programming.

**JP52** connects SOT0 or SOT1 to UART “A” and to X17 (FlashKit)

**JP53** connects SIN0 or SIN1 to UART “A” and to X17 (FlashKit)

**JP54** connects SCK0 or SCK1 to UART “A” and to X17 (FlashKit)

Jumper	Setting	Description
JP52 (SOTx)	1-2	SOT0 (MB90340 bootloader UART) is connected to UART ‘A’
	2-3 <sup>*1</sup>	SOT1 (MB91270 bootloader UART) is connected to UART ‘A’
JP53 (SINx)	1-2	SIN0 (MB90340 bootloader UART) is connected to UART ‘A’
	2-3 <sup>*1</sup>	SIN1 (MB91270 bootloader UART) is connected to UART ‘A’
JP54 (SCKx)	1-2	SCK0 (MB90340 bootloader UART) is connected to UART ‘A’
	2-3 <sup>*1</sup>	SCK1 (MB91270 bootloader UART) is connected to UART ‘A’

Default: JP52=2-3, JP53=2-3, JP54=2-3

By default, UART1 is used as UART“A”.

**\*1 Note for MB91270 Series:**

Make sure that jumper JP21a and JP22a (LIN transceiver) on the FLASH-CAN-100P-340 are open, while the UART1 of MB91270 Series is used.

## 5 Programming the internal Flash

All Flash devices have an internal bootloader for asynchronous- as well as synchronous-Flash-programming:

- ▶ asynchronous-serial Flash-programming via X3 (UART "A") of FLASH-CAN-100P-340
- ▶ synchronous-serial Flash-programming via X17 ("FlashKit") of FLASH-CAN-100P-340

### 5.1 Asynchronous Mode

The Flash-microcontroller of MB90340, MB96340, and MB91270 Series can be programmed in circuit by using the freeware "Fujitsu Flash MCU Programmer" that is available on the Fujitsu Micros CD-ROM or Web Site (<http://www.fme.gsdc.de/gsd.c.htm>: select ▶ Software ▶ Utilities)

MB90340 and MB96340 Series use UART0 for in circuit programming.

**Note:** Basically MB96340 supports programming via UART0-URAT3

MB91270 Series uses UART1 for in circuit programming.

**Note:** Open jumper JP16 of FLASH-CAN-100P-340 because P10 is used for mode selection.

Please check the correct UART selection in chapter 4.4.

The following procedure must be followed to enable Flash Programming:

1. Power off the system
2. Connect the Evaluation Board UART"A" to your serial PC communication port. A straight cable connection (1:1) has to be used.
3. Check the Jumper-settings according to the UART as described in chapter 4.4.
4. Configure by Dip-Switch S2 the mode related to your microcontroller:

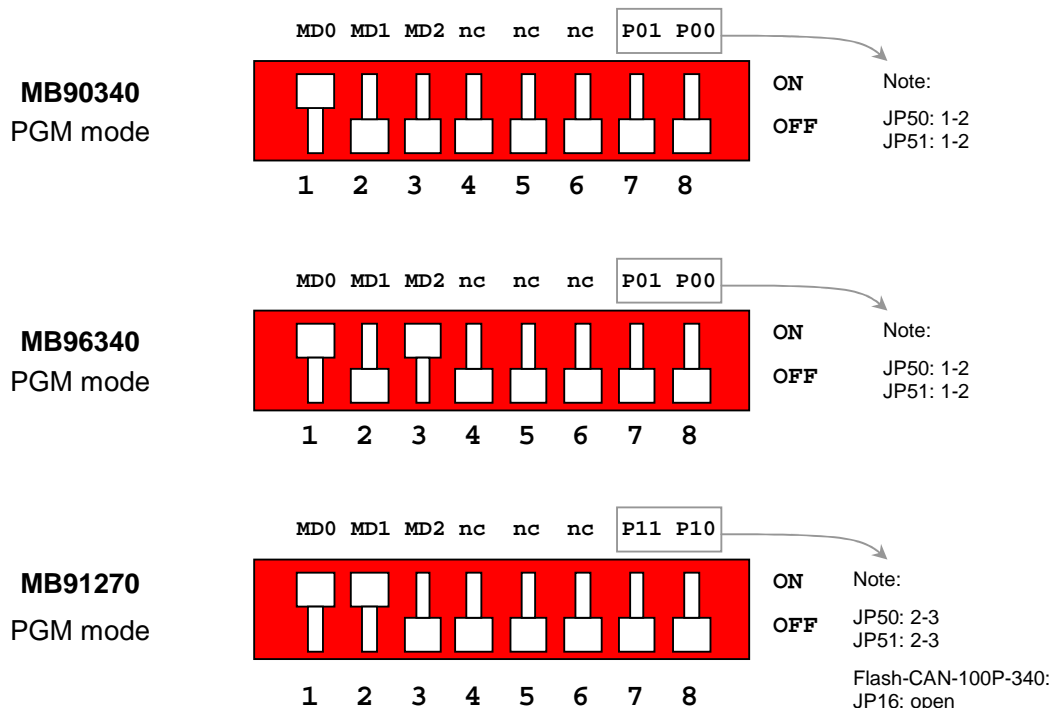

- Power on the board
- Check that the Reset LED is off. Otherwise change the DTR polarity (JP35) and check the power supply voltage.
- Start the tool "Fujitsu Flash MCU Programmer" software and follow the instructions:  
**Note:** The screenshot may differ regarding the used release version of the tool

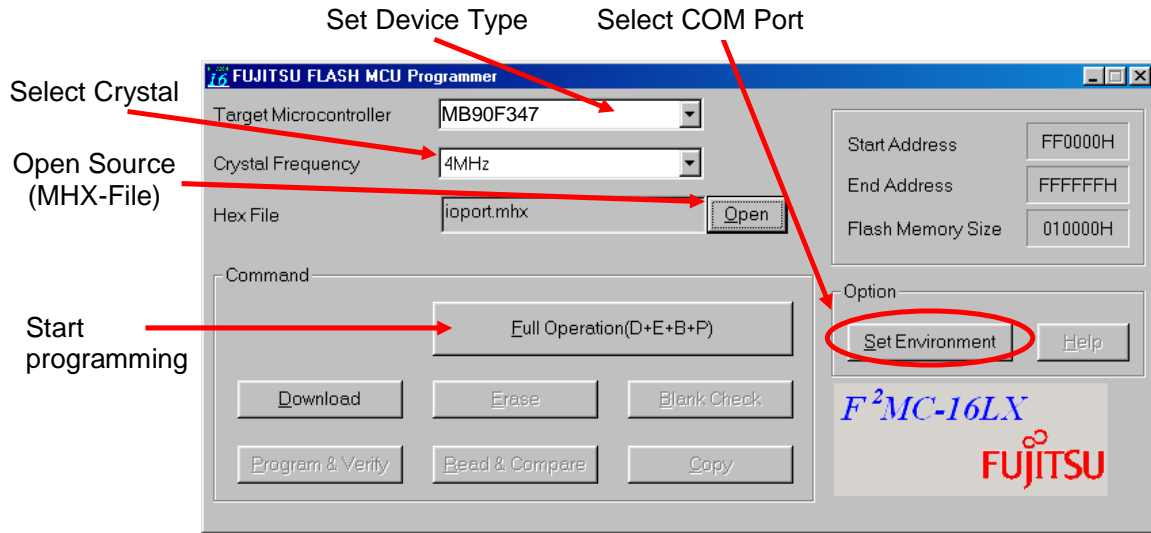

- After programming the Flash-ROM, switch off the power supply and set back the mode according to the usage of the application, e.g.:

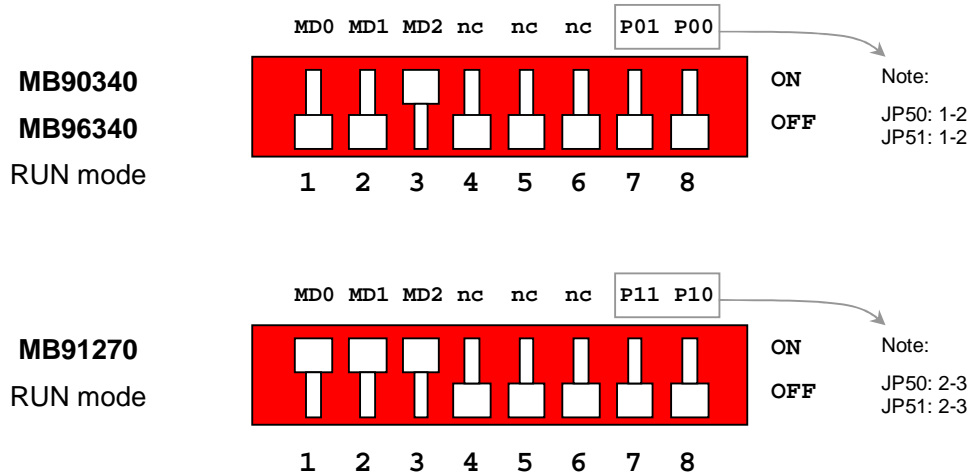

- Power on the board. The user application is started directly.



## 6 Connectors

### 6.1 Edge connector (X3, X4)

Nearly<sup>\*1</sup> all pins of the microcontroller are directly connected to X3 and X4 as follows:

Connector <sup>*1</sup>	MCU Pins <sup>*1</sup>
X3 (1 – 50)	1 – 50
X4 (51 – 100)	51 – 100

The odd pin numbers are located on the one side and the even pin numbers are located on the other side of the connector.

On the PCB, the corresponding pin numbers of the  $\mu$ C are written next to the connector pins.

**\*1Note:**

The following pins are not routed to the connector (X3, X4):

Pin 90 (X1)

Pin 91 (X0)

## 7 Silk-Plot of the Board

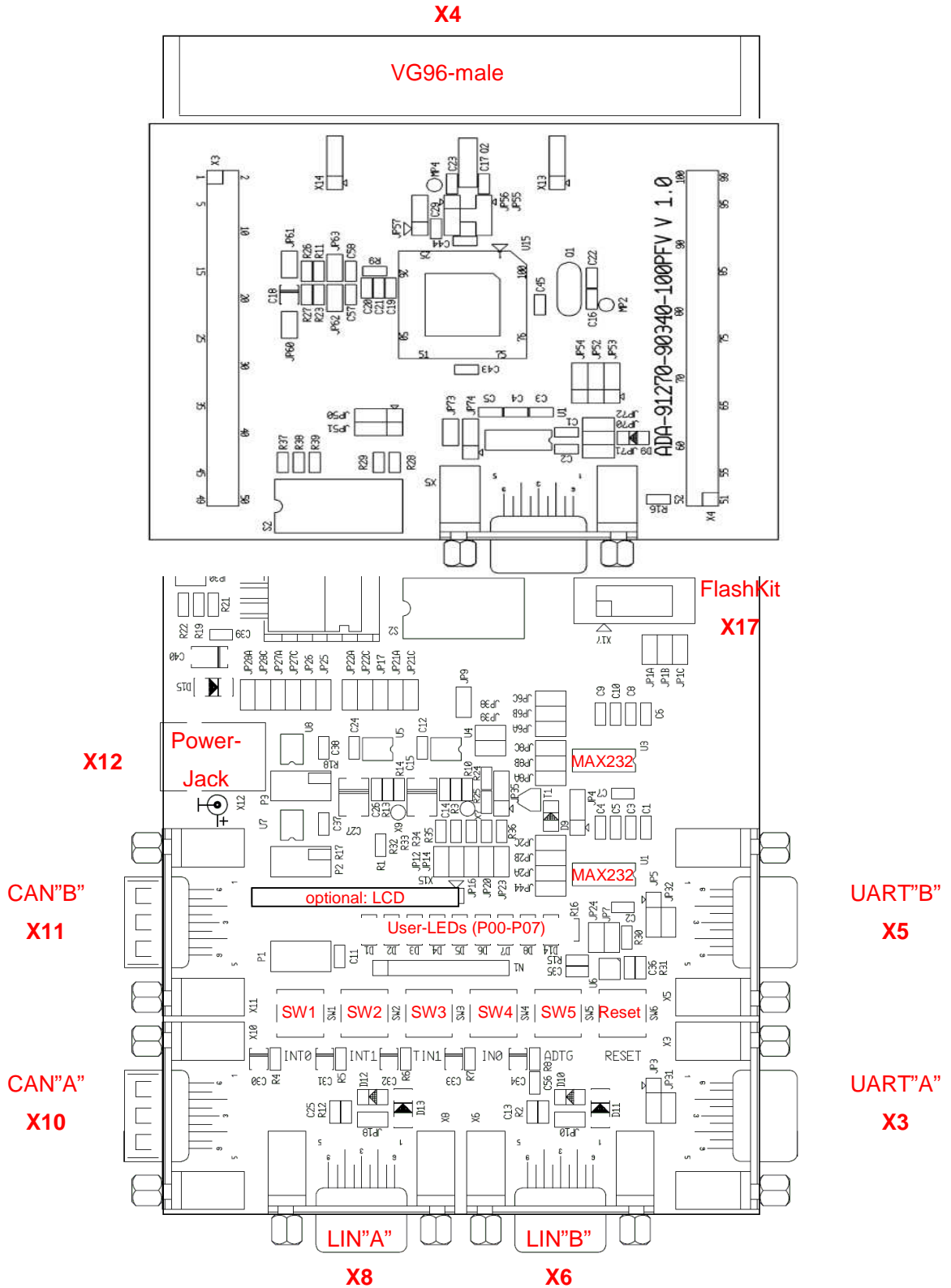

## 8 Notes on using the ADA-91270-90340-100PFV V1.1

### 8.1 Stand-alone mode

The MB91F272 does not have an internal power-on reset circuitry. Therefore, when using the MB91F272 on the ADA-91270-90340-100PFV in stand-alone mode, a reset must be generated externally after powering-up the board.

### 8.2 PCB History

Part	Problem	Fixed
	No known issues.	

## 9 Related Products

- ▶ FLASH-CAN-100P-340 Evaluation board for MB90340, MB90800, MB90860, MB90945, MB96340 Series with FPT-100P-M06 package
- ▶ ADA-91270-90340-100PFV Adapterboard for M05/M20 (PFV) Package of MB90340, MB96340, and MB91270 Series
- ▶ NQPack100SD-ND Socket for package FPT-100P-M05, FPT-100P-M20 (Tokyo Eletech Corp. [www.tetc.co.jp/e\\_tet.htm](http://www.tetc.co.jp/e_tet.htm))
- ▶ HQPack100SD Header for NQPack100SD-ND
  
- ▶ MB90340 Series
  - ▶ MB90F34xS\_PFV Flash-MCU (M05 package), single-clock
  - ▶ MB90F34x\_PFV Flash-MCU (M05 package), dual-clock
  - ▶ MB2147-01 Emulator debugger main unit
  - ▶ MB2147-20 Emulation adapter
  - ▶ MB90V340A-101 Evaluation chip for MB90340 Series, single-clock
  - ▶ MB90V340A-102 Evaluation chip for MB90340 Series, dual-clock
  - ▶ MB90V340A-103 Eval.-chip for MB90340 Series, single-clock, incl. RC-osc
  - ▶ MB90V340A-104 Eval.-chip for MB90340 Series, dual-clock, incl. RC-osc
  - ▶ MB2147-581 Emulator probe cable for MB90340/M05 Package
  
- ▶ MB96340 Series
  - ▶ MB96F34x\_PFV Flash-MCU (M20 package)
  - ▶ MB2198-01 Emulator debugger main unit
  - ▶ MB2198-500 Emulation adapter
  - ▶ MB96V300 Evaluation chip for MB96340 Series
  
- ▶ MB91270 Series
  - ▶ MB91F27xS\_PFV Flash-MCU (M05 package), single-clock
  - ▶ MB91F27x\_PFV Flash-MCU (M05 package), dual-clock
  - ▶ MB2198-01 Emulator debugger main unit
  - ▶ MB2198-10 Emulator DSU cable
  - ▶ MB2198-130 Emulation POD
  - ▶ MB91V280CR-ES Evaluation chip for MB91270 Series, single-clock
  - ▶ MB2198-129 Emulator probe cable for MB91270/M05 Package

## 10 Information in the WWW

Information about FUJITSU MICROELECTRONICS Products can be found on the following Internet pages:

Microcontrollers (8-, 16-, and 32bit), Graphics Controllers  
Datasheets and Hardware Manuals, Support Tools (Hard- and Software)

<http://www.fme.gsdc.de/gsd.htm>

Linear Products: Power Management, A/D and D/A Converters

<http://www.fujitsu.com/emea/services/microelectronics/linears/>

Media Products: SAW filters, acoustic resonators and VCOs

<http://www.fujitsu.com/emea/services/microelectronics/saw/>

For more information about FUJITSU MICROELECTRONICS

<http://www.fujitsu.com/emea/services/microelectronics/>



## 11 China-RoHS regulation

### Evaluation Board 评估板

### Emulation Board 仿真板

根据SJ/T11364-2006

《电子信息产品污染控制标识要求》特提供如下有关污染控制方面的信息。

The following product pollution control information is provided according to SJ/T11364-2006 *Marking for Control of Pollution caused by Electronic Information Products*.

#### 1. 电子信息产品污染控制标志说明 Explanation of Pollution Control Label



该标志表明本产品含有超过中国标准SJ/T11363-2006

《电子信息产品中有毒有害物质的限量要求》中限量的有毒有害物质。标志中的数字为本产品的环保使用期，表明本产品在正常使用的条件下，有毒有害物质不会发生外泄或突变，用户使用本产品不会对环境造成严重污染或对其人身、财产造成严重损害的期限，单位为年。

为保证所声明的环保使用期限，应按产品手册中所规定的环境条件和方法进行正常使用，并严格遵守产品维修手册中规定的定期维修和保养要求。

产品中的消耗件和某些零部件可能有其单独的环保使用期限标志，并且其环保使用期限有可能比整个产品本身的环保使用期限短。应到期按产品维修程序更换那些消耗件和零部件，以保证所声明的整个产品的环保使用期限。

本产品在使用寿命结束时不可作为普通生活垃圾处理，应被单独收集妥善处理。

请注意：环保使用期限50年的指定不是与产品的耐久力，使用期限或任何担保要求等同的。

This symbol to be added to all EIO sold to China, indicates the product contains hazardous materials in excess of the limits established by the Chinese standard SJ/T11363-2006 *Requirements for Concentration Limits for Certain Hazardous Substances in Electronic Information Products*. The number in the symbol is the Environment-friendly Use Period (EFUP), which indicates the period, starting from the manufacturing date, during which the toxic or hazardous substances or elements contained in electronic information products will not leak or mutate under normal operating conditions so that the use of such electronic information products will not result in any severe environmental pollution, any bodily injury or damage to any assets, the unit of the period is "Year".

In order to maintain the declared EFUP, the product shall be operated normally according to the instructions and environmental conditions as defined in the product manual, and periodic maintenance schedules specified in Product Maintenance Procedures shall be followed strictly.

Consumables or certain parts may have their own label with an EFUP value less than the product. Periodic replacement of those consumables or parts to maintain the declared EFUP shall be done in accordance with the Product Maintenance Procedures.

This product must not be disposed of as unsorted municipal waste, and must be collected separately and handled properly after decommissioning.

Please note: The designation of 10 years EFUP is not to be equated with the durability, use-duration or any warranty-claims of the product.

产品中有毒有害物质或元素的名称及含量

Table of hazardous substances name and concentration

部件名称 Component Name	有毒有害物质或元素 Hazardous substances name					
	铅 (Pb)	汞 (Hg)	镉 (Cd)	六价铬 (Cr(VI))	多溴联苯 (PBB)	多溴二苯醚 (PBDE)
ADA-91270-90340-100PFV v1.1	x	o	o	o	o	o

- O:** 表示该有毒有害物质在该部件所有均质材料中的含量均在SJ/T11363-2006 标准规定的限量要求以下
- X:** 表示该有毒有害物质至少在该部件的某一均质材料中的含量超出SJ/T11363-2006 标准规定的限量要求
- 此表所列数据为发布时所能获得的最佳信息
  - 由于缺少经济上或技术上合理可行的替代物质或方案，此医疗设备运用以上一些有毒有害物质来实现设备的预期临床功能，或给人员或环境提供更好的保护效果。
- O: Indicates that this toxic or hazardous substance contained in all of the homogeneous materials for this part is below the limit requirement in SJ/T11363-2006.
- X: Indicates that this toxic or hazardous substance contained in at least one of the homogeneous materials used for this part is above the limit requirement in SJ/T11363-2006.
- Data listed in the table represents best information available at the time of publication





## 12 Recycling

### **Gültig für EU-Länder:**

Gemäß der Europäischen WEEE-Richtlinie und deren Umsetzung in landesspezifische Gesetze nehmen wir dieses Gerät wieder zurück.

Zur Entsorgung schicken Sie das Gerät bitte an die folgende Adresse:

Fujitsu Microelectronics Europe GmbH  
Warehouse/Disposal  
Monzastraße 4a  
63225 Langen

### **Valid for European Union Countries:**

According to the European WEEE-Directive and its implementation into national laws we take this device back.

For disposal please send the device to the following address:

Fujitsu Microelectronics Europe GmbH  
Warehouse/Disposal  
Monzastraße 4a  
63225 Langen