

Visual Signals ROTATING

BEACONS

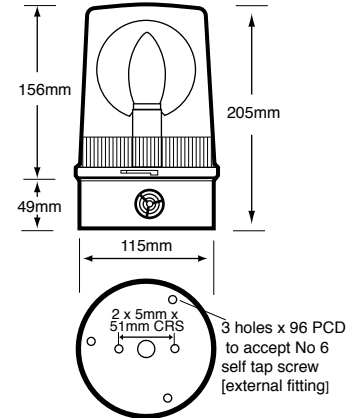

Industrial Rotating Beacons > RA201/200 Series

Product overview

The RA201/200 Series uses a parabolic reflector which, driven by an electric motor, revolves around a continuously illuminated lamp on the vertical axis of the beacon creating a powerful beam of light travelling

through 360 degrees. Generally, this type of beacon has a greater degree of light output than other models but this is off-set by the fact that the parabolic reflector only illuminates one given point at a time. The RA series also incorporates a Piezo Buzzer producing 85db, giving the user the peace of mind of two signals in one unit.

Features

- Continuously rated
- Suitable for use with conduit BESA box
- Suitable for surface or wall mounting
- Optional wall bracket & protective guard available – see accessory page
- Two signals in one unit
- Twin belt drive system
- IP65

Material

- UV Stable Polycarbonate Lens
- UV Stable ABS Mounting Base

Code No:	Voltage:	Light Source:	Current:
RA201-20	12v Dc ---	H1 x 55w	4.70 A
RA201-21	24v Dc ---	H1 x 70w	3.00 A
RA201-64	48v Dc ---	Ba15d x 35w	0.55 A
RA200-03	24v Ac ~	Ba15d x 48w	2.00 A
RA200-02	48v Ac ~	Ba15d x 35w	0.55 A
RA200-24	115v Ac ~	Ba15d x 60w	0.55 A
RA200-25	230v Ac ~	Ba15d x 60w	0.29 A



Kg 0.86

50 Hz

°C -10+55

IP 65

RPM 160±30 DC

RPM 120 AC



ADD THE FOLLOWING LENS CODES TO THE PRODUCT CODE WHEN ORDERING

01 **02** **03** **04** **05**



dB 85