

## **PGA309EVM-USB**

This user's guide describes the characteristics, operation, and use of the PGA309EVM-USB evaluation module (EVM). This EVM is designed to evaluate the performance of the [PGA309](#), a voltage output, programmable sensor conditioner. This document covers all pertinent areas involved to properly use this EVM board, allowing for user evaluation suitable to a variety of applications. This document also includes the physical printed circuit board (PCB) layout and circuit descriptions. A [schematic of the PGA309EVM-USB](#) is available as a separate download from the TI web site.

### Contents

1	Introduction and Overview .....	2
2	System Setup .....	5
3	PGA309EVM-USB Hardware Setup .....	16
4	PGA309EVM-USB Software Overview .....	25

### List of Figures

1	Hardware Included with the INA282-286EVM.....	3
2	PGA309EVM-USB Hardware Setup.....	5
3	PGA309_Test_Board Block Diagram .....	5
4	PGA309_Test_Board Schematic: Input Circuitry .....	7
5	PGA309_Test_Board Schematic: Power, Reference, and Digital Connections .....	8
6	PGA309_Test_Board Schematic: Output Circuitry .....	9
7	PGA309_Test_Board Schematic: Sensor Emulator Circuitry.....	10
8	PGA309_Test_Board Connections to USB-DAQ-Platform and EEPROM.....	11
9	Theory of Operation For USB-DAQ-Platform .....	16
10	PGA309EVM-USB Typical Hardware Connections.....	17
11	Connecting the Two EVM PCBs .....	18
12	Connecting Power to the EVM.....	19
13	Connecting the USB Cable.....	20
14	Default Jumper Settings (PGA309_Test_Board).....	21
15	Default Jumper Settings (USB-DAQ-Platform) .....	22
16	PGA309EVM-USB Software: Block Diagram.....	26
17	PGA309EVM-USB Software: Registers Tab.....	27
18	PGA309EVM-USB Software: Set-Up Cal Tab.....	28
19	PGA309EVM-USB Software: Auto Calibrate Tab .....	29
20	PGA309EVM-USB Software: EEPROM Tab .....	30
21	PGA309EVM-USB Software: Set-Up Cal Tab with Select Model File Dialog .....	31
22	PGA309EVM-USB Software: Set-Up Cal Tab with Create Model Dialog.....	32
23	PGA309EVM-USB Software: Set-Up Cal Tab with Sensor Emulator Control Tool Dialog .....	33
24	PGA309EVM-USB Software: Set-Up Cal Tab with Configure DMM Interface Dialog.....	34
25	PGA309EVM-USB Software: Auto Calibrate Tab with Auto-Continue Feature Enabled .....	35
26	PGA309EVM-USB Software: Auto Calibrate Tab at Start of Calibration Process .....	36

Microsoft, Windows are registered trademarks of Microsoft Corporation.  
I<sup>2</sup>C is a trademark of NXP Semiconductors.  
All other trademarks are the property of their respective owners.

27	PGA309EVM-USB Software: Auto Calibrate Tab with Calibration in Progress .....	37
28	PGA309EVM-USB Software: Auto Calibrate Tab with Second Calibration in Progress .....	38
29	PGA309EVM-USB Software: Auto Calibrate Tab with Both Calibrations Complete .....	39
30	PGA309EVM-USB Software: Create Model, Select Pre-Cal File .....	40
31	PGA309EVM-USB Software: Create Model Dialog with Create Pre-Cal File Active .....	41
32	PGA309EVM-USB Software: Create Model Dialog with Create Sensor File Active.....	42
33	PGA309EVM-USB Software: Create Model Dialog with Model ID Active .....	43
34	PGA309EVM-USB Software: Create Model Dialog with Save File Active .....	44
35	PGA309EVM-USB Software: Create Pre-Cal File Dialog with Sensor Emulator Control Tool.....	45
36	PGA309EVM-USB Software: Create Sensor Emulator File .....	47
37	PGA309EVM-USB Software: Create Sensor Emulator File with Additional Tabs .....	48
38	PGA309EVM-USB Software: Create Sensor Emulator File by Entering Raw Bridge Sensor Data .....	49
39	PGA309EVM-USB Software: Create Sensor Emulator File by Entering Temperature Data .....	50
40	PGA309EVM-USB Software: Save a Created Sensor Emulator File .....	51

#### List of Tables

1	PGA309 Test Board Parts List.....	12
2	J1 Pinout (25-Pin Male DSUB) .....	14
3	J2 Pinout (25-Pin Female DSUB) .....	15
4	PGA309_Test_Board Jumper Functions: General.....	22
5	PGA309_Test_Board Jumper Functions: Miscellaneous Connections.....	23
6	PGA309_Test_Board Jumper Functions: Sensor Emulator Section .....	23
7	USB-DAQ-Platform Jumper Settings .....	24
8	Create Pre-Cal File Field Descriptions .....	46

## 1 Introduction and Overview

This document provides the information needed to set up and operate the PGA309EVM-USB evaluation module, a test platform for the [PGA309](#) programmable sensor conditioner. For a more detailed description of the PGA309, refer to the product data sheet ([SBOS292](#)) available from the Texas Instruments web site at <http://www.ti.com>. Additional support documents are listed in the section of this guide entitled *Related Documentation from Texas Instruments*.

The PGA309EVM-USB is an evaluation module that is used to fully evaluate the PGA309. The PGA309 is an integrated circuit that provides temperature compensation and linearization for bridge sensors. The PGA309EVM-USB consists of two PCBs. One board (the USB-DAQ-Platform) generates the digital signals required to communicate with the PGA309. The other board (the PGA309\_Test\_Board) contains the PGA309 device, as well as support and configuration circuitry.

Throughout this document, the abbreviation *EVM* and the term *evaluation module* are synonymous with the PGA309EVM-USB.

## 1.1 PGA309EVM-USB Hardware

Figure 1 shows the hardware included with the PGA309EVM-USB kit. Contact the factory if any component is missing. It is highly recommended that you check the TI web site (at <http://www.ti.com>) to verify that you have the latest software. It is also recommended that you refer to the [PGA309 User's Guide](#) if you have questions about the PGA309 device itself.

The complete kit includes the following items:

- PGA309\_Test\_Board
- USB DAQ Platform Board
- USB cable
- 6V wall power-supply unit
- CD-ROM containing this user's guide and product software

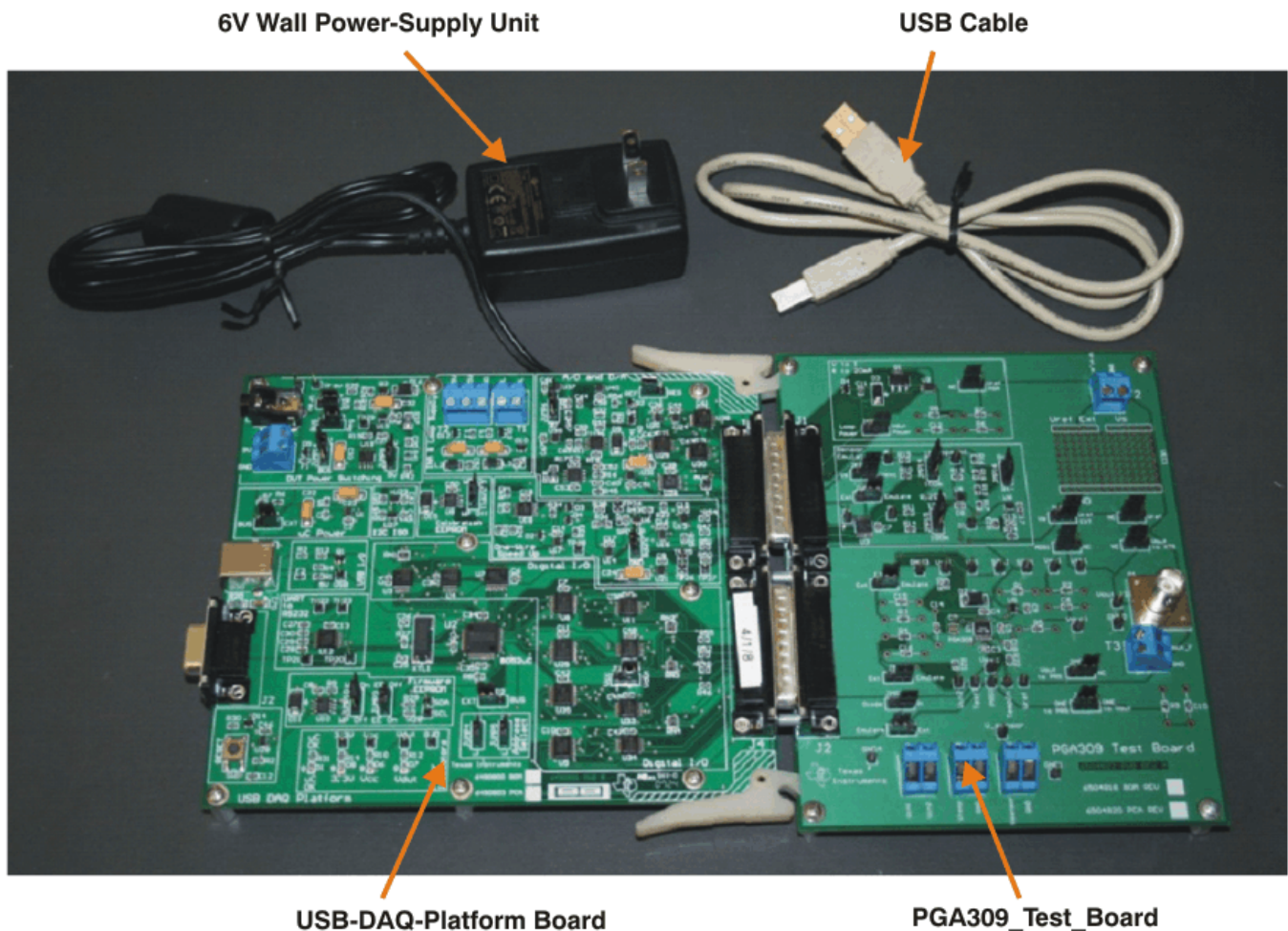

Figure 1. Hardware Included with the INA282-286EVM

## 1.2 Related Documentation from Texas Instruments

The following documents provides information regarding Texas Instruments integrated circuits used in the assembly of the PGA309EVM-USB. This user's guide is available from the TI web site under literature number [SBOU084](#). Any letter appended to the literature number corresponds to the document revision that is current at the time of the writing of this document. Newer revisions may be available from the TI web site at <http://www.ti.com>, or call the Texas Instruments Literature Response Center at (800) 477-8924 or the Product Information Center at (972) 644-5580. When ordering, identify the document by both title and literature number.

Document	Literature Number
PGA309	<a href="#">SBOS292</a>
USB DAQ Platform Users Guide	<a href="#">SBOU056</a>
PGA309 Users Guide	<a href="#">SBOU024</a>
OPA333 Product Data Sheet	<a href="#">SBOS351</a>
DAC8555 Product Data Sheet	<a href="#">SLAS475</a>
XTR117 Product Data Sheet	<a href="#">SBOS344</a>
PGA309EVM-USB Schematic	<a href="#">SBOR010</a>
Sensor-Emulator EVM Reference Guide	<a href="#">SBOA102</a>

## 1.3 If You Need Assistance

If you have questions about the PGA309EVM-USB evaluation module, send an e-mail to the Linear Application Team at [precisionamps@list.ti.com](mailto:precisionamps@list.ti.com). Include *PGA309EVM-USB* as the subject heading.

## 1.4 Information About Cautions and Warnings

This document contains caution statements.

### CAUTION

This is an example of a caution statement. A caution statement describes a situation that could potentially damage your software or equipment.

## 2 System Setup

Figure 2 shows the system setup for the PGA309EVM. The PC runs software that communicates with the USB-DAQ-Platform. The USB-DAQ-Platform generates the digital signals used to communicate with the PGA309\_Test\_Board. Connectors on the PGA309\_Test\_Board allow for connection to the bridge sensor.

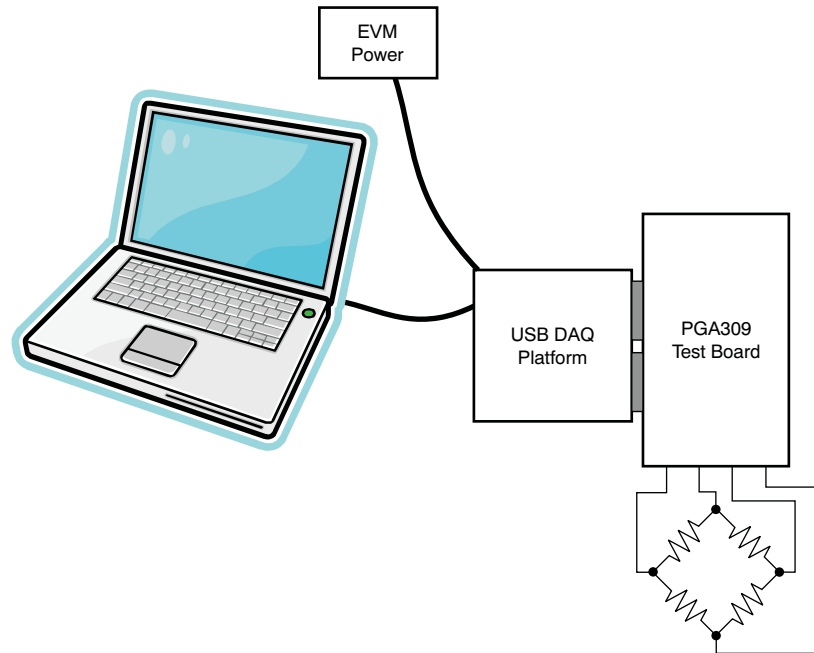

Figure 2. PGA309EVM-USB Hardware Setup

### 2.1 Theory of Operation for PGA309\_Test\_Board Hardware

Figure 3 shows the block diagram of the PGA309\_Test\_Board. The PGA309\_Test\_Board provides connections to the I<sup>2</sup>C™, one-wire, analog-to-digital converters (ADCs) and digital-to-analog converters (DACs) on the USB-DAQ-Platform. It also provides connection points for external connection of the bridge sensor. The PGA309\_Test\_Board has circuitry to convert the PGA309 voltage output to 4mA to 20mA current.

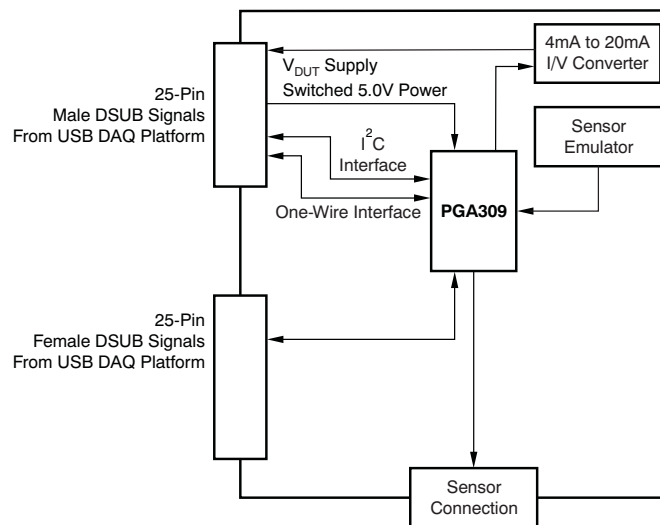

Figure 3. PGA309\_Test\_Board Block Diagram

The PGA309\_Test\_Board also has an onboard sensor emulator. The sensor emulator is a circuit that generates the same type of signals generated by a bridge sensor. The sensor emulator circuit is controlled by the PGA309EVM-USB software. Using the sensor emulator allows you to get a deeper understanding of the PGA309EVM-USB software and hardware more quickly. When the capabilities and functions of the PGA309EVM-USB are fully understood, you can connect the real-world sensor to the EVM and perform a full calibration.

Note that calibrations with real-world sensors are time-consuming because devices such as these are normally calibrated at multiple temperatures in an environmental chamber. It is not unusual for temperature calibration to require 12 hours.

## 2.2 PGA309\_Test\_Board Connections

See [Figure 4](#) for the input connections on the PGA309\_Test\_Board schematic. T1 provides the power connection for an external bridge sensor. T4 allows connections to each input of the external bridge sensor. T5 allows connection of the external temperature sensor. JMP7, JMP4, JMP5, and JMP6 allow users to select either the onboard sensor emulator or an external sensor. JMP12 allows users to choose between  $V_S$  or  $V_{EXC}$  for the sensor power.

The input is filtered with R3, R4, C14, C15, and C16. Note that C14 is ten times larger than C15, and C16 is used for good ac common-mode rejection. The cutoff frequency of this filter is 40.6Hz ( $f = 1/(2 \pi R3 C14)$ ). This input filter is recommended in your final design if you have available board space.

$V_{EXC}$  has a 100pF capacitor and TEMPIn has a 1nF capacitor. These components are also recommended in your final design.

Refer to [Figure 5](#) to see the power, reference, and digital connections on the PGA309\_Test\_Board schematic. T2 provides a connection for an external reference voltage. JMP1 and JMP2 allow users to select between the internal reference, an external reference, or power-supply reference. JMP7 and JMP8 allows users to connect the One-Wire signal to the PRG pin directly or through  $V_{OUT}$ .

D2 is a transient voltage suppressor. It is useful in helping to prevent damage in an electrical overstress (EOS) condition. R5 is useful in preventing EOS damage to the output. C6 filters noise at the output. C5 filters the reference output. These components are recommended for your design if PCB space permits. C4 is a decoupling capacitor; it is required in the final design.



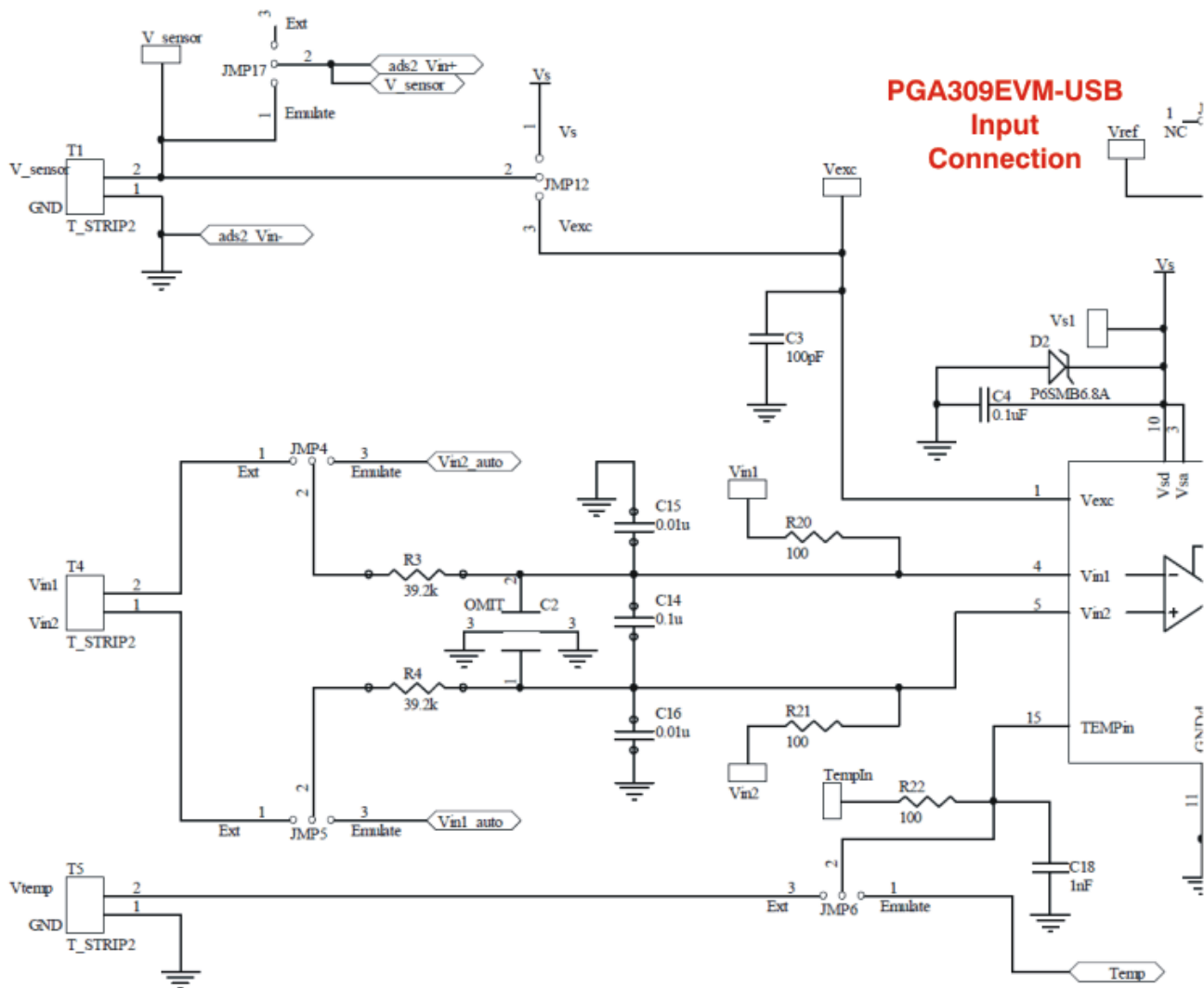

Figure 4. PGA309\_Test\_Board Schematic: Input Circuitry

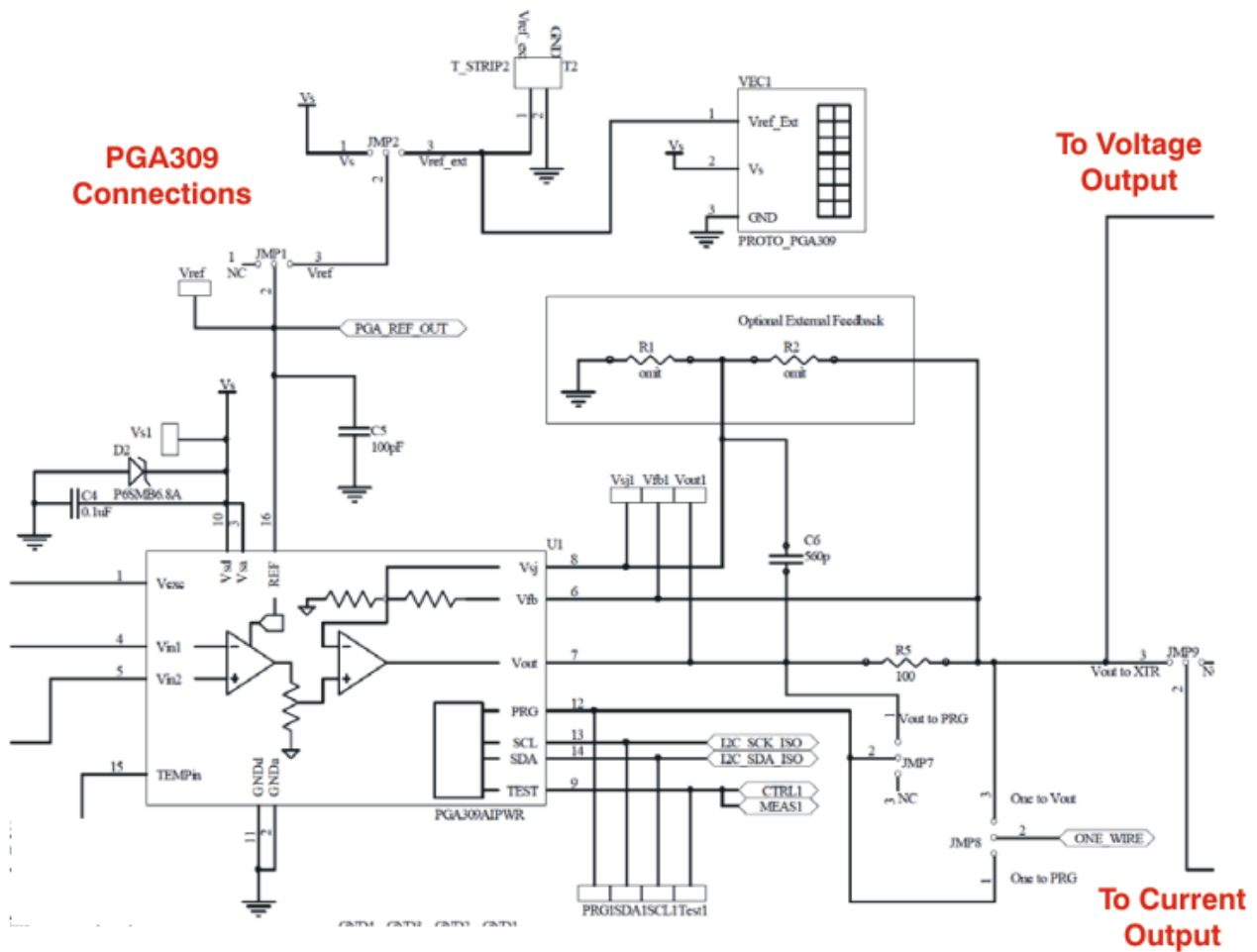

Figure 5. PGA309\_Test\_Board Schematic: Power, Reference, and Digital Connections



Figure 6 shows the output section of the PGA309EVM\_Test\_Board. There are two output options: voltage output and current output. The voltage output option is selected by placing JMP9 in the NC position. The current output option is selected by moving JMP9 to the  $V_{OUT}$  to XTR position.

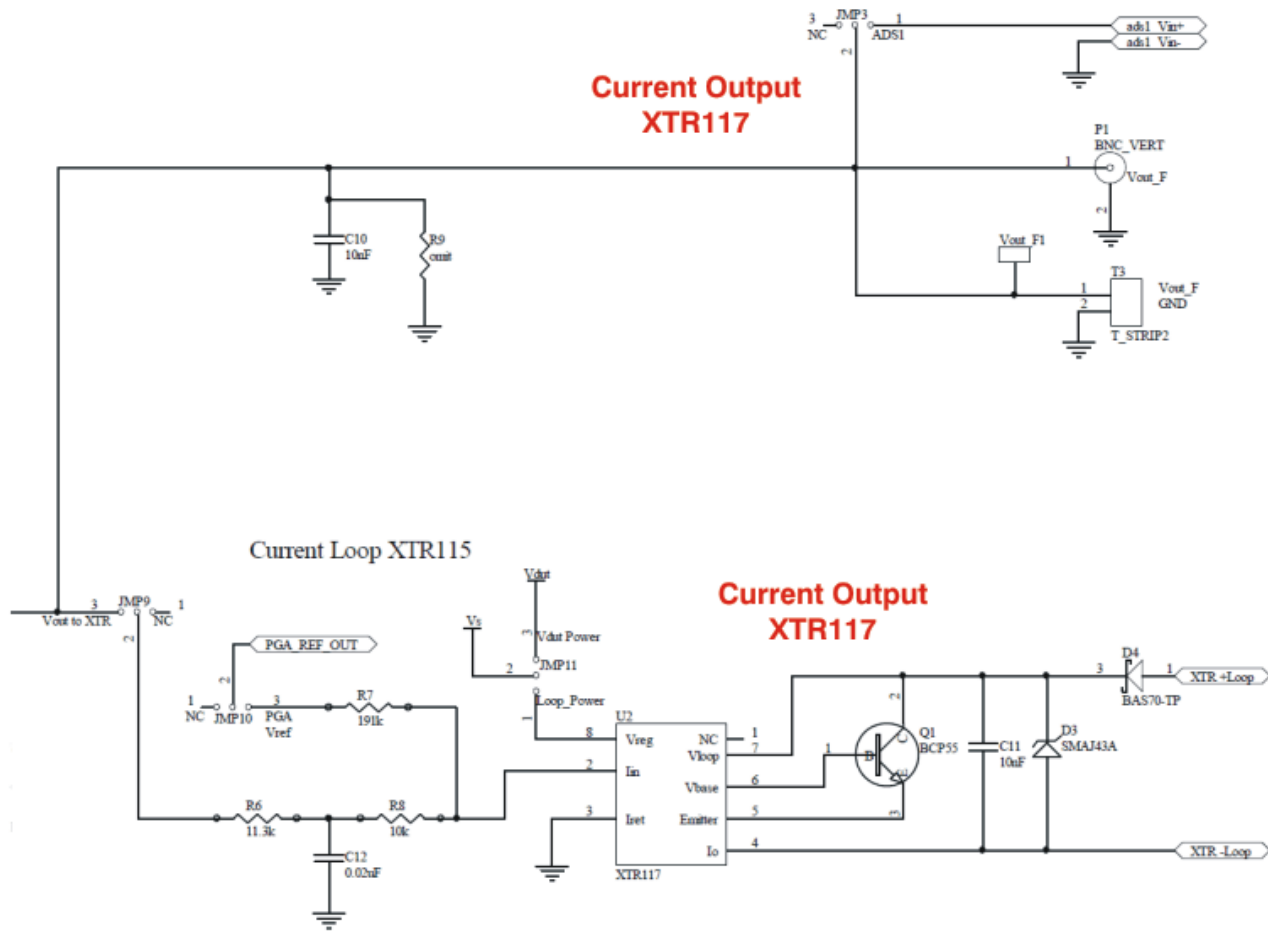

Figure 6. PGA309\_Test\_Board Schematic: Output Circuitry

In voltage output mode, C10 = 10nF is connected to the PGA309 output. This capacitor is used for radio frequency interference (RFI) and electromagnetic interference (EMI) immunity. This component should be included in your design, if possible.

In current output mode, the PGA309 output is connected to a voltage-to-current (V-I) converter ([XTR117](#)). The sum of R6 and R8 convert the output voltage from the PGA309 to an input current for the XTR117. R7 can be used to create an input offset current using the reference. The total input current is  $I_{IN} = V_{OUT} / (R6 + R8) + V_{REF}/R7$ . The output current is equal to the input current times the current gain (x 100).

D4 is used for reverse polarity protection. D3 is used for over-voltage transient protection. D3 was selected for low leakage. Leakage on D3 directly contributes to error. C11 is a decoupling capacitor and is required for proper operation. The external transistor, Q1, conducts the majority of the full-scale output current. Power dissipation in this transistor can approach 0.8W with high loop voltage (40V) and 20mA output current.

Figure 7 shows the sensor emulator circuit. The sensor emulator generates signals to help users evaluate the PGA309. No part of this circuit is required in your final design. The sensor emulator uses a [DAC8555](#) (U8) to generate an emulated temperature signal, common-mode signal, and differential signal. These signals can be controlled using software to produce levels that closely match real-world sensors.

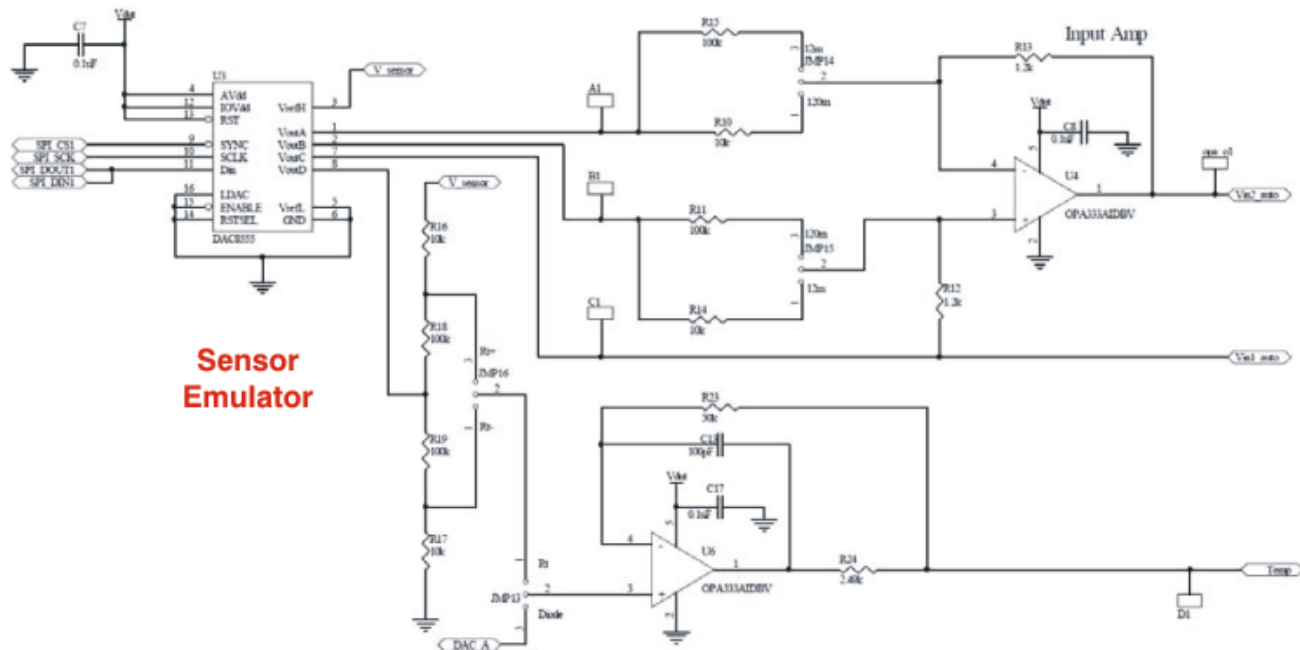

**Figure 7. PGA309\_Test\_Board Schematic: Sensor Emulator Circuitry**

The operational amplifier U4 and associated resistors is a differential amplifier with jumper selectable attenuation. The possible attenuations are 0.12 and 0.012. The attenuation produces a more accurate and stable emulated sensor output. For example, when the DAC outputs 3V, the sensor emulator outputs  $3V \times 0.012 = 36mV$  (assuming that attenuation is set in the 0.012 position). Thus, the maximum output of the sensor emulator is 120mV/V and 12mV/V.

The op amp U6 buffers the emulated temperature signal. Resistors R16, R17, R18, and R19 are used to attenuate the DAC output for temperature emulation and to reference the temperature signal to supply or ground. JMP13 allows the resistor network to be bypassed for direct connection to the DAC (diode temperature sensor mode).

Figure 8 illustrates the two 25-pin D-SUB connectors J1 and J2. These connectors provide all the signals necessary to communicate with the PGA309. U5 is the EEPROM used to store the calibration look-up table used with the PGA309.

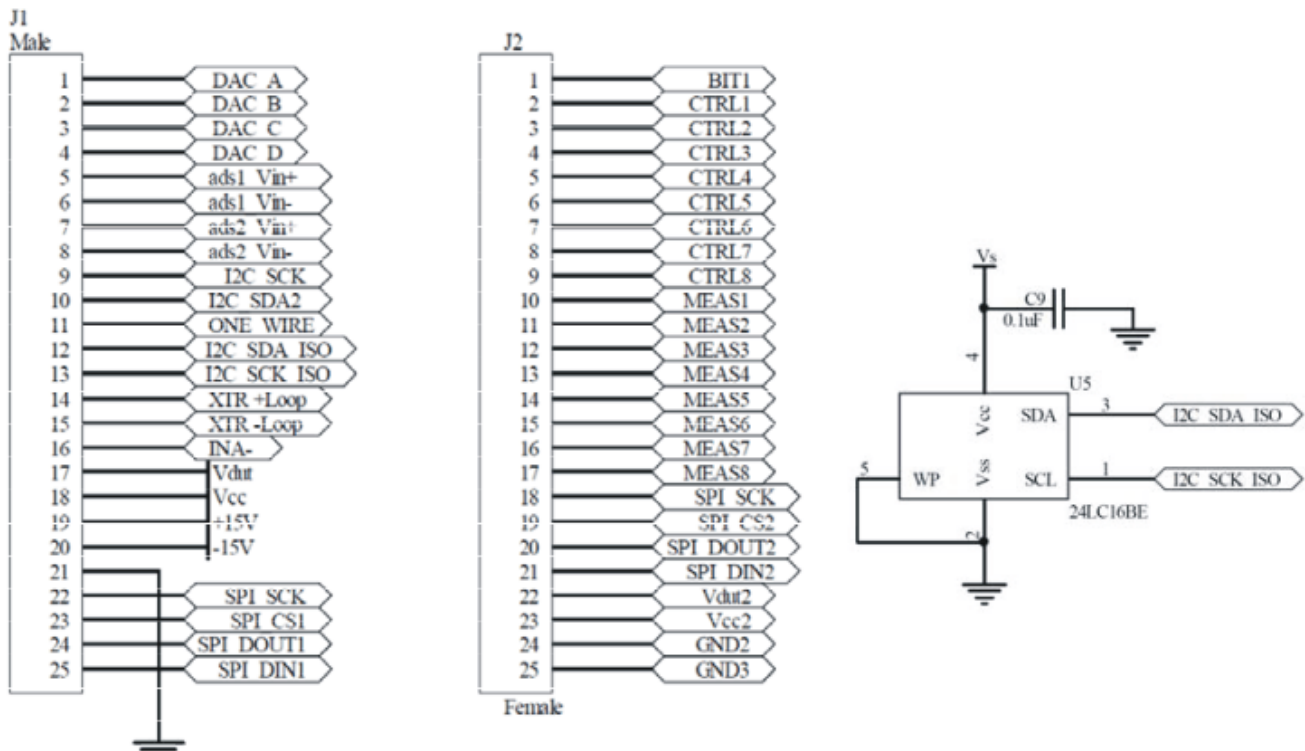

Figure 8. PGA309\_Test\_Board Connections to USB-DAQ-Platform and EEPROM

### 2.3 PGA309\_Test\_Board Parts List

Table 1 describes the parts list for the PGA309\_Test\_Board.

**Table 1. PGA309 Test Board Parts List**

Qty	Value	Ref Des	Description	Vendor	Part Number
1	560pF	C6	Capacitor, ceramic 560pF 50V NP0 0603	Panasonic - ECG	ECJ-1VC1H561J
3	100pF	C3 C5, C13	Capacitor, ceramic 560pF 50V NP0 0603		ECJ-1VC2A101J
6	0.1µF	C4, C7, C8, C9, C14, C17	Capacitor, 0.1µF 25V, ceramic Y5V 0603	Kemet	CC0603ZRY5V8BB104
2	.01µF	C15, C16	Capacitor, ceramic .01µF 10% 100V X7R 0603	AVX	06031C103KAT2A
1	1nF	C18	Capacitor, 1000pF, 100V, ceramic X7R 0603	Panasonic - ECG	ECJ-1VB2A102K
2	10nF	C10, C11	Capacitor, 10000pF, 50V, ceramic X7R 0603	Kemet	C0603C103K5RACTU
1	0.02µF	C12	Capacitor, ceramic 22000pF, 100V X7R 10%0603	TDK Corporation	C1608X7R2A223K
1	1000pF	C2	Omit; not installed	JOHANSON DIELECTRICS	501R18W102KV4E
4	100kΩ	R11, R15, R18, R19	Resistor, 100kΩ 1/6W 0.1% 0603 SMD	Susumu Co Ltd	RGH1608-2C-P-104-B
2	1.2kΩ	R12, R13	Resistor, 1.2kΩ 1/6W 0.1% 0603 SMD	Susumu Co Ltd	RGH1608-2C-P-122-B
5	10kΩ	R8, R10, R14, R16, R17	Resistor, 10.0kΩ 1/6W 0.1% 0603 SMD	Susumu Co Ltd	RGH1608-2C-P-103-B
4	100Ω	R5, R20, R21, R22	Resistor, 100kΩ 1/10W 1% 0603 SMD	Yageo Corporation	RC0603FR-07100RL
1	191kΩ	R7	Resistor, 191kΩ 1/10W 1% 0603 SMD	Yageo Corporation	ERJ-3EKF1913V
1	11.3kΩ	R6	Resistor, 11.3kΩ 1/10W 1% 0603 SMD	Yageo Corporation	ERJ-3EKF1132V
2	39.2kΩ	R3, R4	Resistor, 39.2kΩ 1/10W 1% 0603 SMD	Yageo Corporation	RC0603FR-0739K2L
1	50kΩ	R23	Resistor, 49.9kΩ 1/16W .5% 0603 SMD	Sunsuma	RR0816P-4992-D-68C
1	2.49kΩ	R24	Resistor, 2.49kΩ 1/16W .5% 0603 SMD	Sunsuma	RR0816P-2491-D-39H
0	omit	R1, R2, R9	Omit; not installed		
1	PGA309	U1	Smart Programmable Sensor	Texas Instruments	PGA309AIPWT
1	BNC	P1	Connector, Jack BNC Vertical 50Ω PCB	Tyco Electronics/Amp	5227699-1
2	OPA333AID BVT	U4 U6	IC Op Amp 1.8V 0-DRIFT SOT23-5	Texas Instruments	OPA333AIDBVT
1	DAC8555	U3	IC DAC 16BIT QUAD 16-TSSOP	Texas Instruments	DAC8555IPW
1	24LC16BT	U5	IC SRL EEPROM 16K 2.5V SOT23-5	Microchip Technology	24LC16BT-I/OT
1	XTR117	U2	IC 4mA-20mA Current-Loop TX 8-MSOP	Texas Instruments	XTR117AIDGKT
1	6.8V transzorb	D2	TVS Zener Unidirectional 600W 6.8V SMB	ON Semiconductor	P6SMB6.8AT3G
1	SMAJ43A	D3	TVS 400W 43V Unidirectional SMA	Micro Commercial Components	SMAJ43A-TP
1	BAS70TP	D4	Diode, Schottky 70V 200mA SOT23	Micro Commercial Components	BAS70TPMSCT-ND
1	NPN	Q1	IC, Transistor NPN SS GP 1.5A SOT23-4	Fairchild Semiconductor	BCP55
5	ED300/2	T1, T2, T3, T4, T5	2-Position Terminal Strip, Cage Clamp, 45°, 15A, Dove-tailed	On-Shore Technology Inc	ED300/2

**Table 1. PGA309 Test Board Parts List (continued)**

Qty	Value	Ref Des	Description	Vendor	Part Number
17	JUMP2 Cut to Size	JMP1, JMP2, JMP3, JMP4, JMP5, JMP6, JMP7, JMP8, JMP9, JMP10, JMP11, JMP12, JMP13, JMP14, JMP15, JMP16, JMP17,	Terminal strip, 3-position, .100 centers, .025 square pins	Samtec	TSW-103-07-G-S
24	TP Cut to Size	V_Sensor, OPA_O1, C1, B1, A, 1 Templn, GND1, D1, GND2, V <sub>EXC</sub> , V <sub>REF</sub> , V <sub>OUT_F1</sub> , V <sub>IN2</sub> , PRG1, V <sub>OUT1</sub> , V <sub>FB1</sub> , V <sub>S1</sub> , SCL1, V <sub>SJ1</sub> , GND4, V <sub>IN1</sub> , SDA1, GND3, Test1,	Terminal strip, 1-position, .100 centers, .025 square pins	Samtec	TSW-101-07-G-S
17	Jumper Shunts	JMP1, JMP2, JMP3, JMP4, JMP5, JMP6, JMP7, JMP8, JMP9, JMP10, JMP11, JMP12, JMP13, JMP14, JMP15, JMP16, JMP17,	Shunt LP w/Handle 2-position, 30AU	Tyco Electronics Amp	881545-2
1	DSUB25M	J1	Connector, D-SUB PLUG R/A 25POS 30GOLD (with Threaded Inserts and Board locks)	AMP/Tyco Electronics	5747842-4
1	DSUB25F	J2	Connector, D-SUB RCPT R/A 25POS 30GOLD (with Threaded Inserts and Board locks)	AMP/Tyco Electronics	5747846-4
4	Standoffs		Standoffs, Hex , 4-40 Threaded, 0.500" length, 0.250" OD, Aluminum Iridite Finish	Keystone	2203
4	Screws		Machine Screw, 4-40x3/8" Phillips PanHead, Steel, Zinc Plated	Building Fasteners	PMS 440 0038 PH

## 2.4 PGA309\_Test\_Board: Signal Definitions and Pinouts

This section provides the signal definitions for the PGA309\_Test\_Board.

### 2.4.1 J1 (25-Pin Male DSUB)

Table 2 shows the different signals connected to J1 on the PGA309\_Test\_Board. This table also identifies signals connected to pins on J1 that are not used on the PGA309\_Test\_Board.

**Table 2. J1 Pinout (25-Pin Male DSUB)**

Pin on J1	Signal	Used on This EVM	PGA309 Pin
1	DAC A	No	
2	DAC B	No	
3	DAC C	No	
4	DAC D	No	
5	ADS1+	No	
6	ADS1-	No	
7	ADS2+	No	
8	ADS2-	No	
9	I2C_SCK	No	
10	I2C_SDA2	No	
11	ONE_WIRE	No	
12	I2C_SCK_ISO	Yes	SCL
13	I2C_SDA_ISO	Yes	SDA
14	XTR_LOOP+	No	
15	XTR_LOOP-	No	
16	INA-	No	
17	V <sub>DUT</sub>	Yes	V <sub>S</sub>
18	V <sub>CC</sub>	No	
19	+15v	No	
20	-15v	No	
21	GND	Yes	GND
22	SPI_SCK	No	
23	SPI_CS1	No	
24	SPI_DOOUT	No	
25	SPI_DIN1	No	

### 2.4.2 J2 (25-Pin Female DSUB)

Table 3 shows the different signals connected to J2 on the PGA309\_Test\_Board. This table also identifies signals connected to pins on J2 that are not used on PGA309\_Test\_Board.

**Table 3. J2 Pinout (25-Pin Female DSUB)**

Pin on J2	Signal	Used on This EVM	PGA309 Pin
1	NC	No	
2	CTRL1	Yes	Convert
3	CTRL2	Yes	GPIO
4	CTRL3	No	
5	CTRL4	No	
6	CTRL5	No	
7	CTRL6	No	
8	CTRL7	No	
9	CTRL8	No	
10	MEAS1	Yes	Warning
11	MEAS2	Yes	GPIO
12	MEAS3	Yes	Overlimit
13	MEAS4	Yes	Critical
14	MEAS5	Yes	ALT
15	MEAS6	No	
16	MEAS7	No	
17	MEAS8	No	
18	SPI_SCK	No	
19	SPI_CS2	No	
20	SPI_DOUT2	No	
21	SPI_DIN2	No	
22	$V_{DUT}$	No	$V_s$
23	$V_{CC}$	No	
24	GND	Yes	GND
25	GND	Yes	GND



## 2.5 Theory of Operation for USB-DAQ-Platform

Figure 9 shows the block diagram for the USB-DAQ-Platform. This platform is a general-purpose data acquisition system that is used on several different Texas Instruments evaluation modules. The details of its operation are included in a separate document (available for download at [www.ti.com](http://www.ti.com)). The block diagram shown in Figure 9 gives a brief overview of the platform. The primary control device on the USB-DAQ-Platform is the [TUSB3210](#).

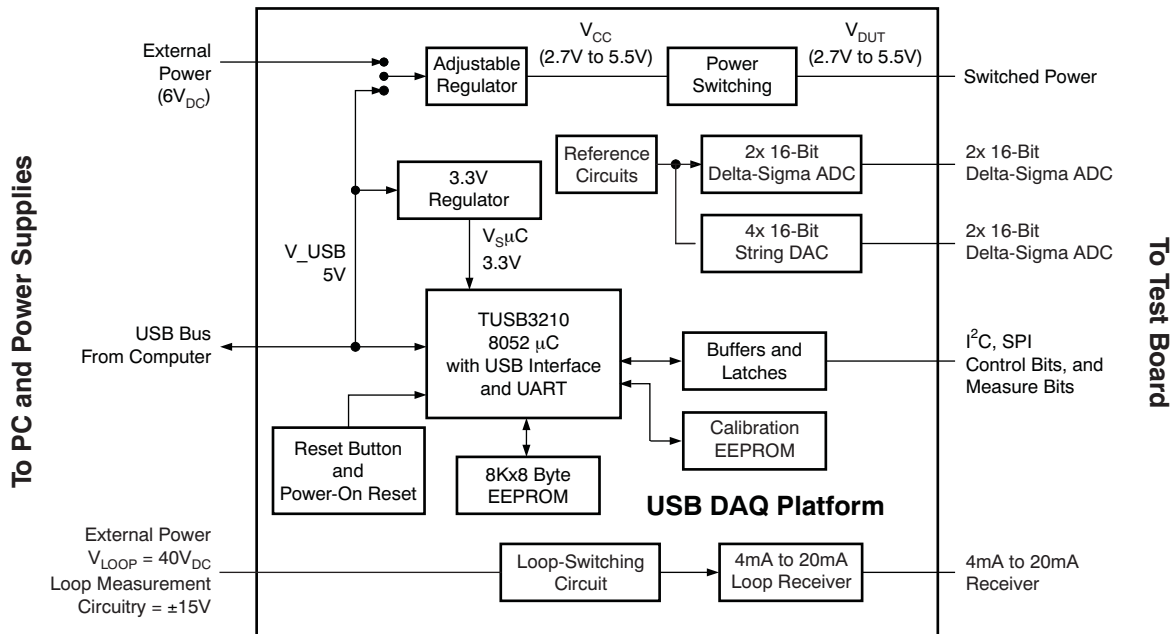

Figure 9. Theory of Operation For USB-DAQ-Platform

## 3 PGA309EVM-USB Hardware Setup

The PGA309EVM-USB Hardware setup involves connecting the two halves of the EVM together, applying power, connecting the USB cable, and setting the jumpers. This section covers the details of this procedure.

### 3.1 Electrostatic Discharge Warning

Many of the components on the PBA309EVM-USB are susceptible to damage by electrostatic discharge (ESD). Customers are advised to observe proper ESD handling precautions when unpacking and handling the EVM, including the use of a grounded wrist strap at an approved ESD workstation.

#### CAUTION

Failure to observe ESD handling procedures may result in damage to EVM components.

### 3.2 Typical Hardware Connections

To set up the PGA309EVM-USB hardware, connect the two halves of the EVM together, apply power, and then connect the external sensor. Figure 10 shows the typical hardware connections.

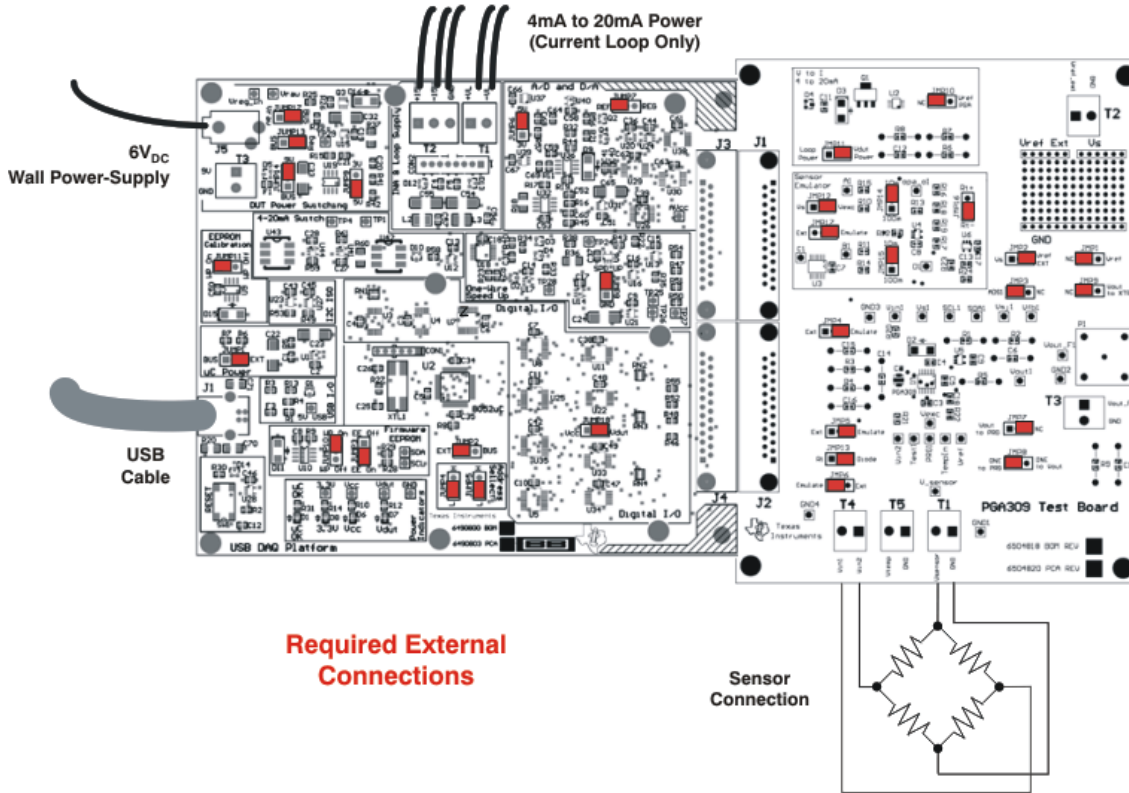
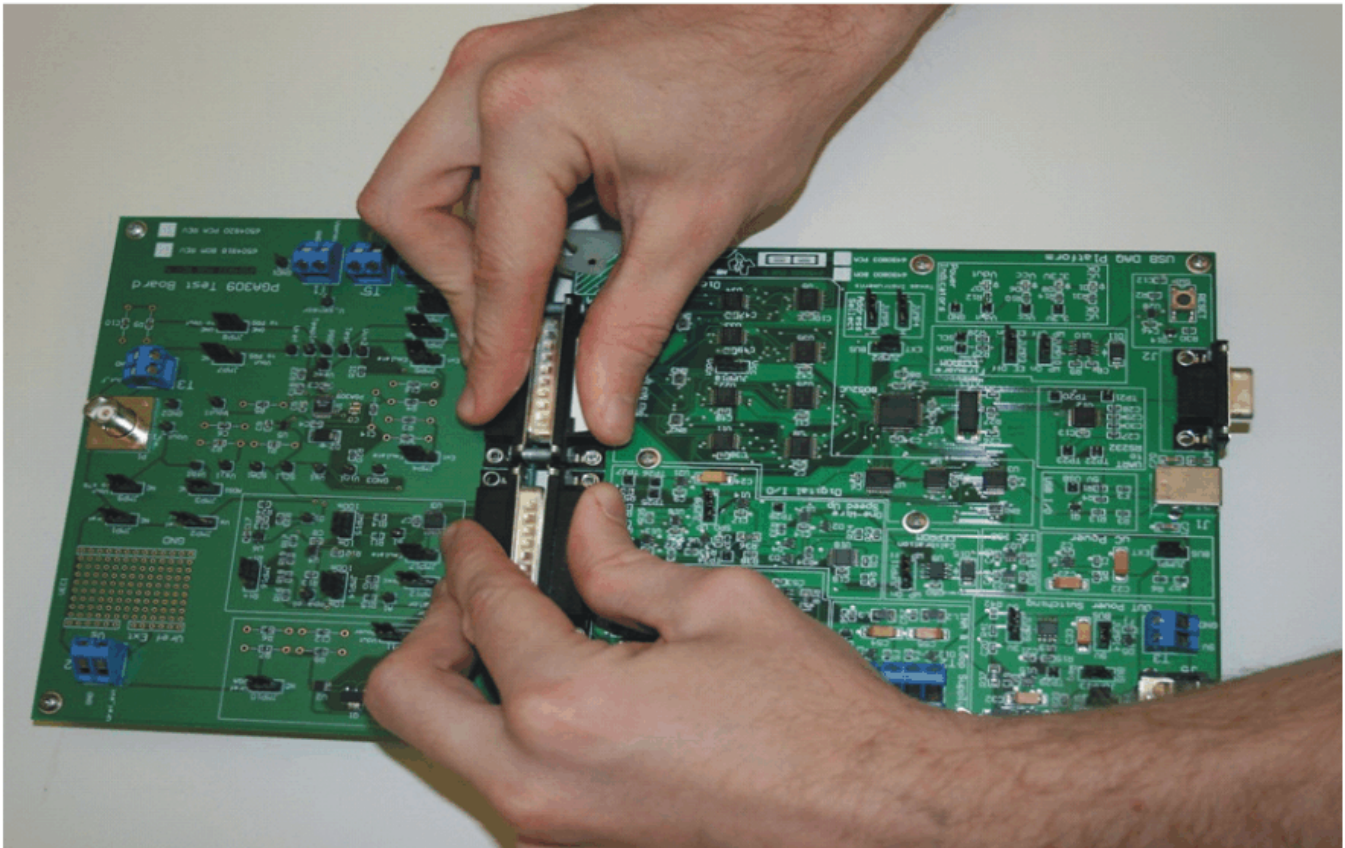

Figure 10. PGA309EVM-USB Typical Hardware Connections

### 3.3 Connecting the Hardware

To connect the two PCBs of the PGA309EVM-USB together, gently push on both sides of the D-SUB connectors (as shown in [Figure 11](#)). Make sure that the two connectors are completely pushed together; that is, loose connections may cause intermittent operation.

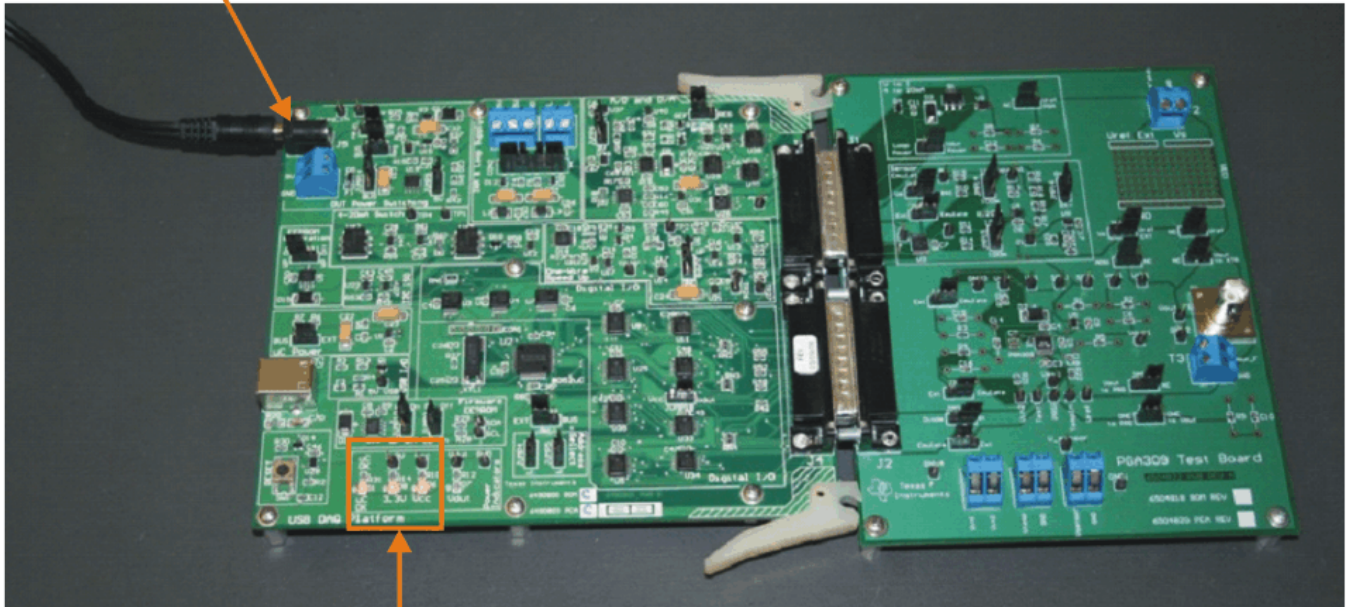

**Figure 11. Connecting the Two EVM PCBs**

### 3.4 Connecting Power

After the two parts of the PGA309EVM-USB are connected, as shown in Figure 12, connect the power to the EVM. Always connect power before connecting the USB cable. If you connect the USB cable before connecting the power, the computer will attempt to communicate with an unpowered device that will not be able to respond.

Connect 6V dc power to J5  
or 9V power to T3



µC OK, 3.3V, and V<sub>CC</sub>  
LEDs all illuminate

Figure 12. Connecting Power to the EVM



### 3.5 Connecting the USB Cable to the PGA309EVM-USB

Figure 13 shows the typical response to connecting the USB-DAQ-Platform to a PC USB port for the first time. Note that the EVM must be powered on before connecting the USB cable. Typically, the computer will respond with a *Found New Hardware, USB Device* pop-up. The pop-up typically changes to *Found New Hardware, USB Human Interface Device*. This pop-up indicates that the device is ready to be used. The USB DAQ platform uses the *Human Interface Device Drivers* that are part of the Microsoft® Windows® operating system.

In some cases, the Windows *Add Hardware Wizard* will pop up. If this prompt occurs, allow the system device manager to install the *Human Interface Drivers* by clicking **Yes** when requested to install drivers.

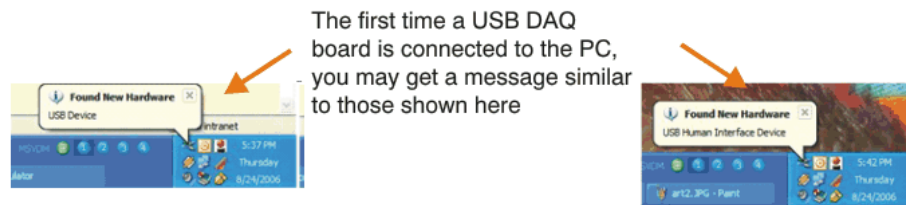
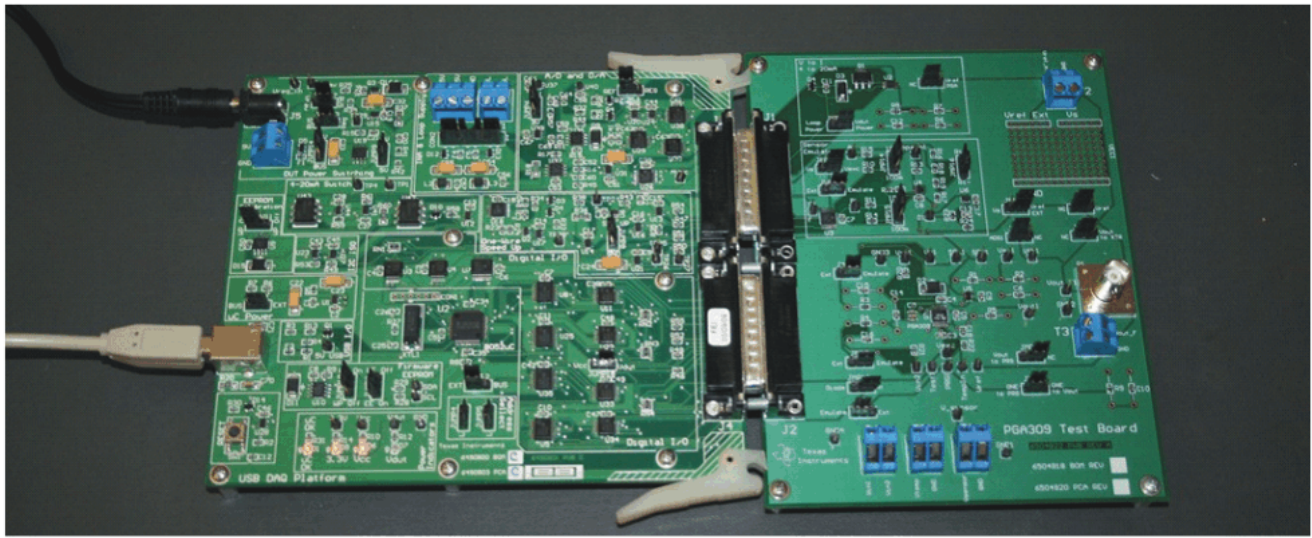

Figure 13. Connecting the USB Cable

### 3.6 PGA309EVM-USB Jumper Settings

Figure 14 illustrates the default jumpers configuration for the PGA309\_Test\_Board. In general, the jumper settings of the USB-DAQ-Platform do not need to be changed. You may want to change some of the jumpers on the PGA309\_Test\_Board to match your specific sensor conditioning design.

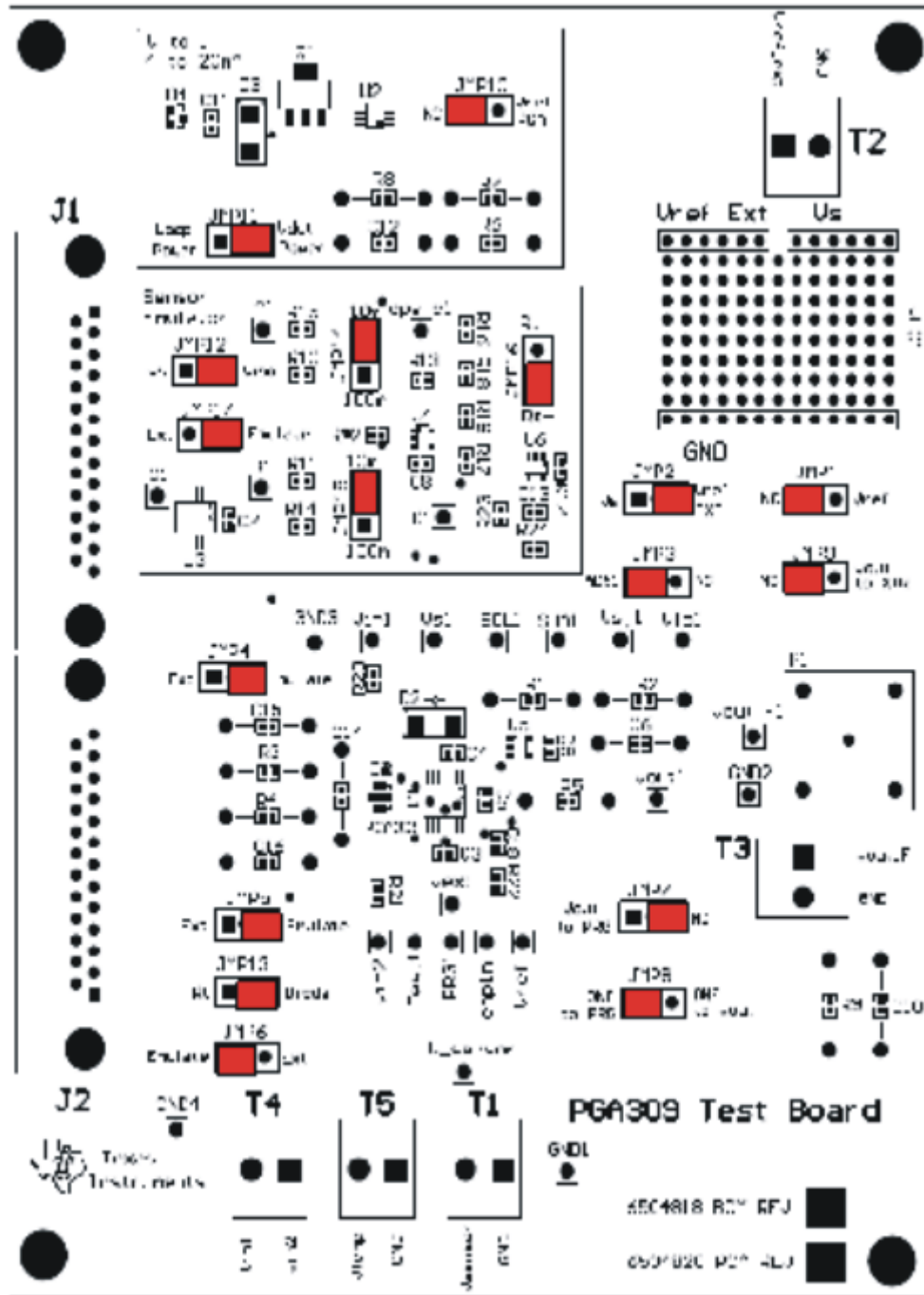

Figure 14. Default Jumper Settings (PGA309\_Test\_Board)

Figure 15 shows the default jumpers configuration for the USB-DAQ-Platform. In general, the jumper settings of the USB-DAQ-Platform do not need to be changed.

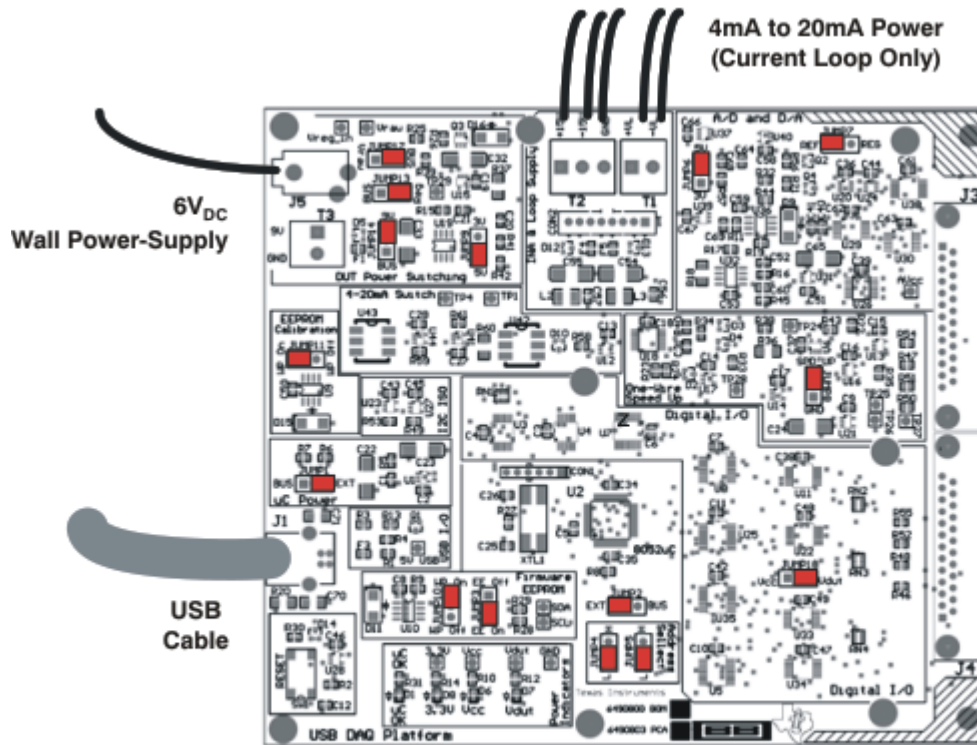

Figure 15. Default Jumper Settings (USB-DAQ-Platform)

Table 4 explains the function of the jumpers on the PGA309\_Test\_Board.

Table 4. PGA309\_Test\_Board Jumper Functions: General

Jumper	Default	Purpose
JMP10	NC	This jumper is used to connect the current loop output (XTR117). For voltage output modules, set this jumper to the <i>NC</i> (no connect) position. For current-loop modules, set this jumper to the <i>Vref PGA</i> position.
JMP11	$V_{DUT}$ power	This jumper is used to connect the current-loop output (XTR117). For voltage output modules, set this jumper to the <i>Vdut Power</i> (5V connected to power) position. For current-loop modules, set this jumper to the <i>Loop Power</i> (power to loop supply) position.
JMP9	NC	This jumper connects the $V_{OUT}$ pin on the PGA309 to the XTR117 input. For voltage output modules, set this jumper to the <i>NC</i> (no connect) position. For current-loop modules, set this jumper to the <i>Vout to XTR</i> position.



Table 5 describes the function of the jumpers in the Miscellaneous connections section of the PGA309 Test Board.

**Table 5. PGA309\_Test\_Board Jumper Functions: Miscellaneous Connections**

Jumper	Default	Purpose
JMP1, JMP2	NC	For JMP1 = NC, JMP2 = $V_{REF\ EXT}$ : The REF pin on the PGA309 is configured for internal reference. In this mode, JMP2 is not connected, so its position does not matter.
	$V_{REF\ EXT}$	For JMP1 = $V_{REF}$ , JMP2 = $V_S$ : The REF pin is configured for external reference and is connected to $V_S$ . For JMP1 = $V_{REF}$ , and JMP2 = $V_{REF\ EXT}$ : The REF pin is configured for external reference and is connected to T2 (terminal for external reference connection).
JMP3	ADS1	For JMP3 = ADS1, it connects the analog-to-digital converter (ADC) on the USB-DAQ-Platform to the output of the PGA309. The ADC on the USB-DAQ-Platform allows full measurement and calibration of the PGA309 without any additional instruments.
		For JMP3 = NC, the ADC on the USB-DAQ-Platform is not connected to the PGA309. This mode is useful if you want to use an external DMM in place of the USB-DAQ ADC.
JMP7, JMP8	NC	For JMP7 = NC, and JMP8 = <i>One to PRG</i> : In this mode, the one-wire signal from the USB-DAQ-Platform is connected directly to the PRG pin on the PGA309. This mode is commonly called <i>Four-wire mode</i> because only four connections are required (Power, GND, $V_{OUT}$ , and PRG).
	One to PRG	For JMP7 = $V_{OUT\ to\ PRG}$ , and JMP8 = <i>One to <math>V_{OUT}</math></i> : In this mode, the one-wire signal from the USB-DAQ-Platform is connected to the $V_{OUT}/PRG$ pin on the PGA309. This mode is commonly called <i>Three-wire mode</i> because only three connections are required (Power, GND, and $V_{OUT}/PRG$ ).

Table 6 explains the function of the jumpers in the sensor emulator section connections section of the PGA309 Test Board.

**Table 6. PGA309\_Test\_Board Jumper Functions: Sensor Emulator Section**

Jumper	Default	Purpose
JMP12	$V_{EXC}$	This jumper selects $V_S$ or $V_{EXC}$ as the reference for the sensor emulator. Using $V_S$ as the reference is commonly called <i>ratimetric mode</i> .
JMP17, JMP4, JMP5, JMP6	Emulate	These jumpers select the sensor emulator when in the Emulate position. When the jumper is in the <i>EXT</i> position, it selects the external sensor.
JMP14, JMP15	10mV	These jumpers select the range of the sensor emulator.
		This jumper is used for the sensor emulator only; its position is not important for externally-connected, real-world sensors.
		10m = maximum emulator output is 10mV/V. 100m = maximum emulator output is 100mV/V.
JMP13, JMP16	RT-, Diode	This jumper selects the type of temperature sensor you will emulate on the EVM. This jumper is used for the sensor emulator only; its position is not important for externally-connected, real-world sensors.
		JMP13 = <i>Diode</i> , JMP16 = <i>RT-</i> . In this position, the temperature sensor emulation is set for diode type temperature sensor. When JMP13 = <i>Diode</i> , the position of JMP16 does not matter.
		JMP13 = <i>RT</i> , JMP16 = <i>RT-</i> . In this position, the temperature sensor emulation is set for RT-.
		JMP13 = <i>RT</i> , JMP16 = <i>RT+</i> . In this position, the temperature sensor emulation is set for RT+.

Table 7 explains the function of the USB-DAQ-Platform jumpers. For most applications the default jumper position should be used. A separate document gives details regarding the operation and design of the USB-DAQ-Platform.

**Table 7. USB-DAQ-Platform Jumper Settings**

Jumper	Default	Purpose
JUMP1	EXT	This jumper selects external power or bus power. External power is applied on J5 or T3 (9V dc). Bus power is 5V from the USB bus. External power is typically used because the USB bus power is noisy.
JUMP2	EXT	Same as JUMP1.
JUMP3	EE ON	This jumper determines where the PGA309 gets its power supply. In the $V_{DUT}$ position, the EVM provides power. The default is the $V_{DUT}$ position. In the $V_{S\_EXT}$ position, the power is connected externally.
JUMP4, JUMP5	L, L	This jumper sets the address for the USB board. The only reason to change from the default is if multiple boards are being used.
JUMP9	5V	This jumper selects the voltage of the device under test supply ( $V_{DUT} = 5V$ or $3V$ )
JUMP10	WP ON	This jumper write-protects the firmware EEPROM.
JUMP11	WP ON	This jumper write-protects the calibration EEPROM
JUMP13	Reg	This jumper configures the regulator output to generate the $V_{DUT}$ supply. The USB bus can be used as the $V_{DUT}$ supply.
JUMP14	9V	This jumper configures the external power (9V as apposed to the bus)
JUMP17	BUS	While in the BUS position $V_{DUT}$ operation is normal. While in the $V_{RAW}$ position, the $V_{DUT}$ supply is connected to an external source. This allows for any value of $V_{DUT}$ between 3V and 5V.
JUMP18	$V_{DUT}$	Connects the pull-up resistor on GPIO to the $V_{DUT}$ supply or the $V_{CC}$ supply.

**CAUTION**

Adjusting the value of  $V_{DUT}$  beyond the range of 3V to 5V will damage the EVM.

## 4 PGA309EVM-USB Software Overview

This section discusses how to install and use the PGA309EVM-USB software.

### 4.1 Operating Systems for PGA309 Software

The PGA309EVM-USB software has been tested on the Microsoft Windows XP operating system (OS) with United States and European regional settings. The software should also function on other Windows operating systems.

### 4.2 PGA309EVM-USB Software Install

Follow these steps to install the PGA309EVM-USB software:

- Step 1. Software can be downloaded from the [PGA309EVM-USB web page](#), or from the disk included with the PGA309EVM-USB, which contains a folder called *Install\_software/*.
- Step 2. Find the file called *setup.exe*. Double-click the file to start the installation process.
- Step 3. Follow the on-screen prompts to install the software.
- Step 4. To remove the application, use the Windows Control Panel utility, *Add/Remove Software*.

### 4.3 Starting the PGA309EVM-USB Software

The PGA309EVM-USB software can be operated through the Windows *Start* menu. From *Start*, select *All Programs*; then select the **PGA309EVM-USB** program. Refer to [Figure 17](#) for a screenshot of how the software should appear if the EVM is functioning properly.

### 4.4 Using the PGA309EVM-USB Software

The PGA309EVM-USB software has five different primary tabs that allow users to access different features of the PGA309 itself. Each tab is designed to provide an intuitive graphical interface that will help users to gain a better understanding of the device.

## 4.5 Block Diagram Tab

The block diagram, illustrated in Figure 16, provides full access to all the elements in the PGA309. Changes made to the block diagram are reflected in the register table. This feature is helpful when users experiment with various aspects of a particular configuration or test setup.

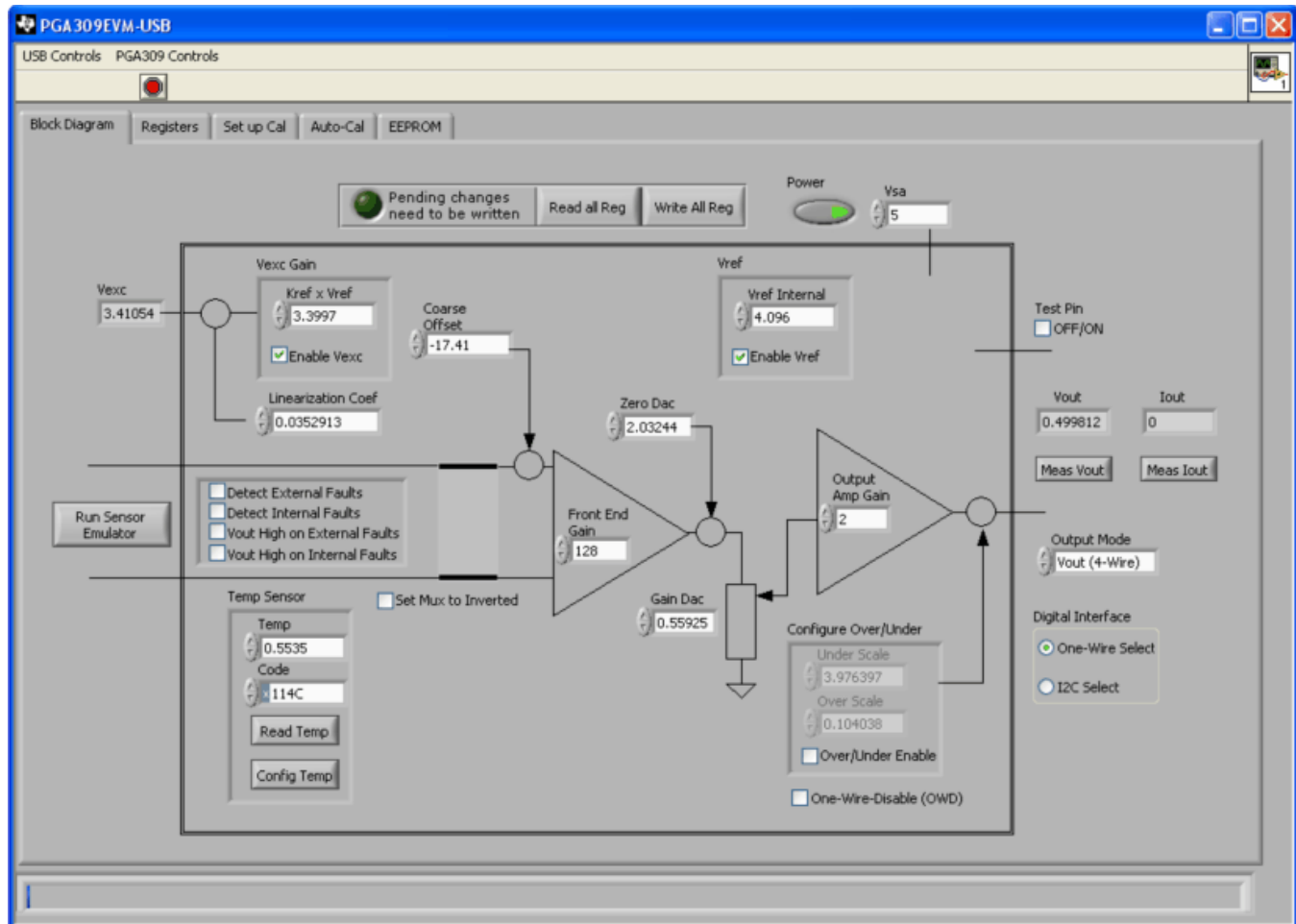

Figure 16. PGA309EVM-USB Software: Block Diagram

## 4.6 Registers Tab

Figure 17 illustrates the Registers tab.

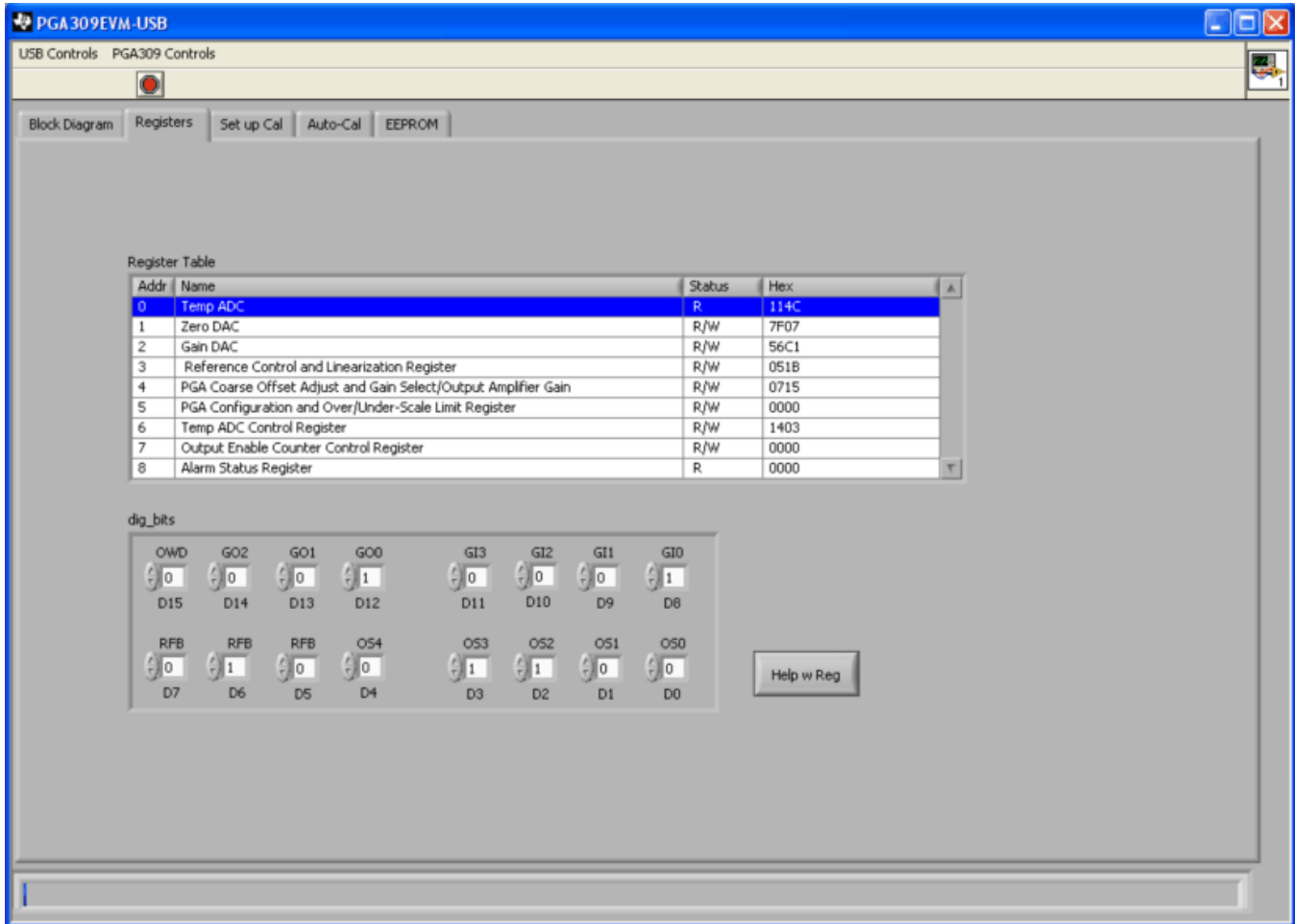
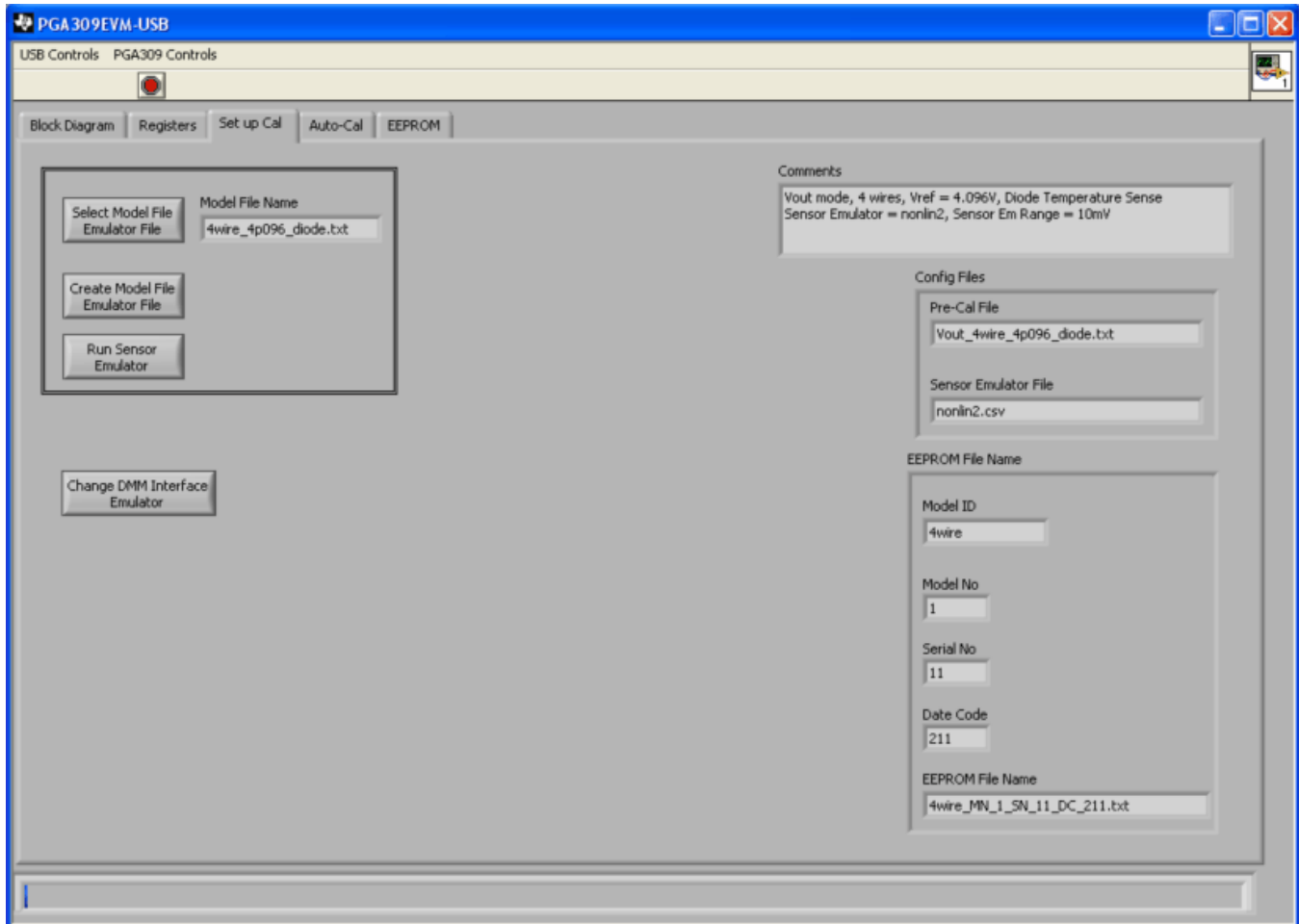

Figure 17. PGA309EVM-USB Software: Registers Tab

This tab presents a *Register Table* that shows a summary of the PGA309 device registers. You can select any row in the table by clicking on it with your mouse. When a row is selected, it is highlighted in blue in the table. The individual 16 bits in the selected register are displayed below the register table. You can edit the bit value by using the up (↑) or down (↓) arrow to the left of the bit. Any changes made to the bit are displayed in the table. Additionally, changes to the device registers initiated on other tabs in the software will also update the Registers tab.

## 4.7 Set-Up Cal Tab

The Set-Up Cal tab (shown in [Figure 18](#)) allows users to create and select files that determine the calibration parameters.



**Figure 18. PGA309EVM-USB Software: Set-Up Cal Tab**

The PGA309 has many different operating modes and features. The purpose of this tab is to enable users to create a *model file* that contains definitions for the operating modes and related features for a particular model. Several different model files can be created to accommodate different user requirements. For example, one model file can be created for a current-loop PGA309 module, and a different model file can be created for a four-wire, voltage-out module. Once a model file is created, the software user does not have to re-enter all the detailed settings when the model is selected and loaded for use. Details on creating and using model files are discussed later in this document; see [Section 4.12](#).

### 4.8 Auto-Cal Tab

As Figure 19 shows, the *Auto-Cal* (or Auto-Calibrate) tab is used to calibrate a PGA309 module over temperature. This process can be done with a real world sensor or with an emulated sensor. It is recommended that you become familiar with the calibration process using the sensor emulator. After you are confident that you understand the calibration process, you can connect your real-world sensor.

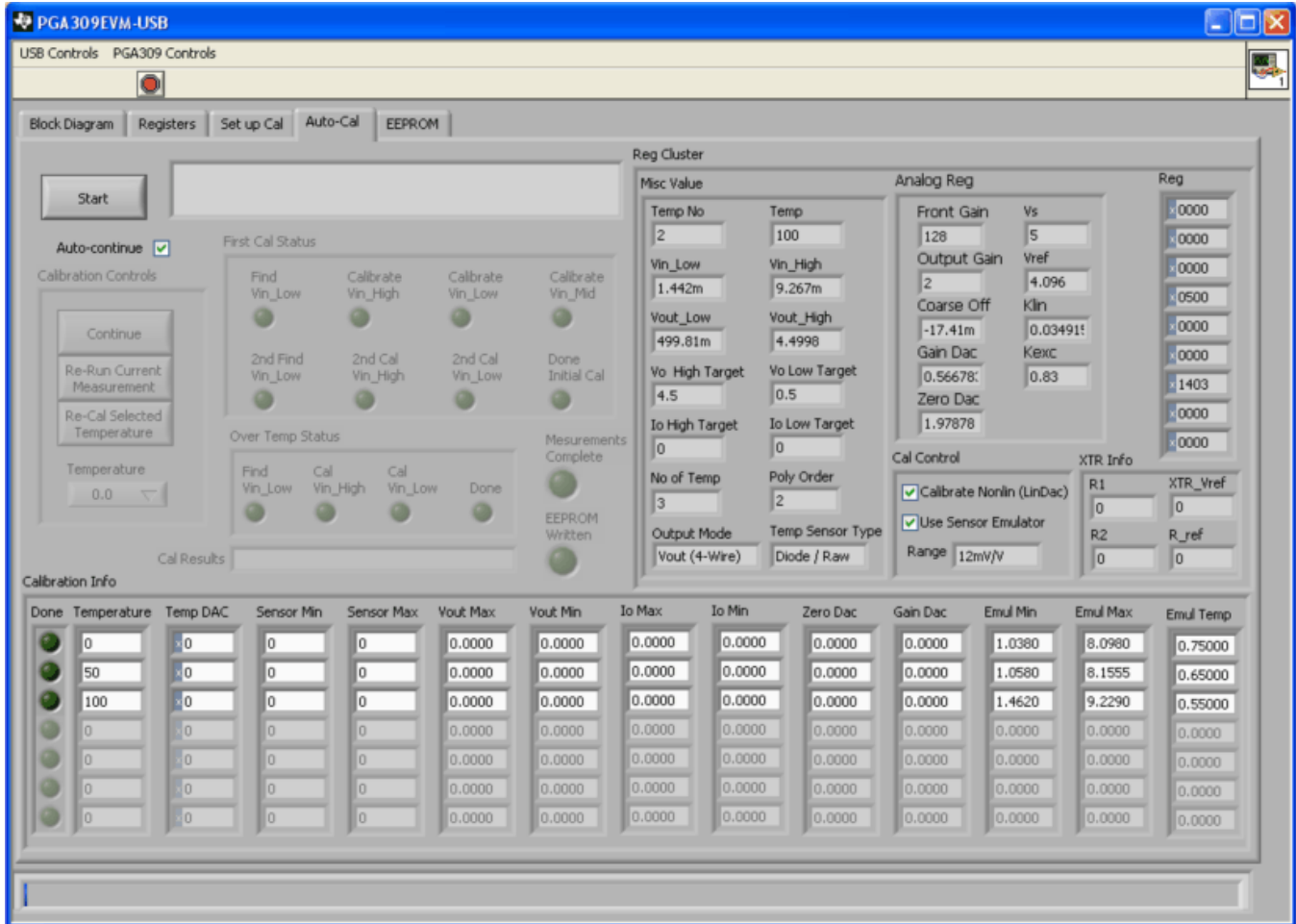
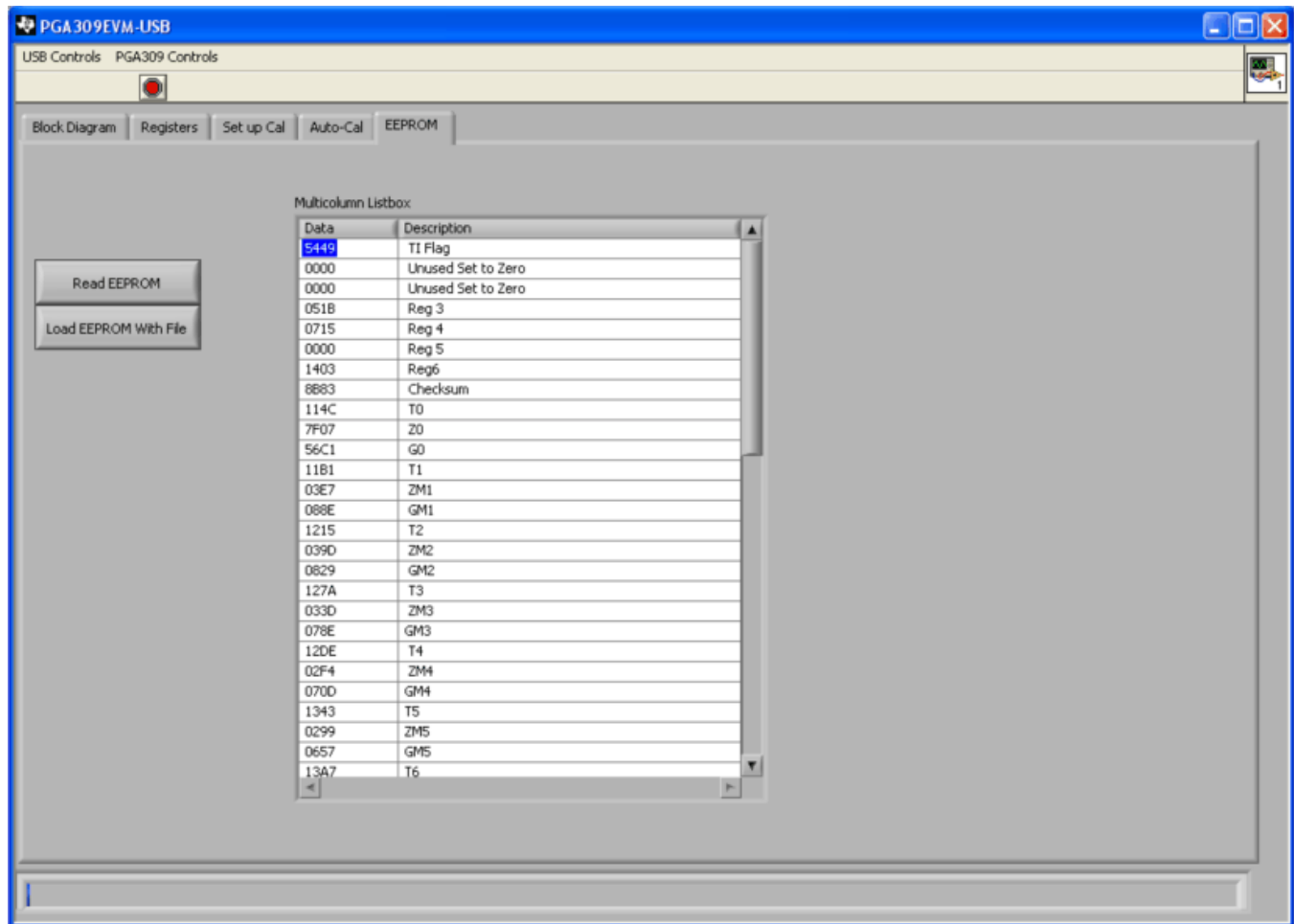

Figure 19. PGA309EVM-USB Software: Auto Calibrate Tab



### 4.9 EEPROM Table Tab

The EEPROM Table tab is shown in Figure 20.



**Figure 20. PGA309EVM-USB Software: EEPROM Tab**

This tab contains displays for the two different sections of the PGA309 EEPROM. In general, users create the EEPROM table in the *Auto-Calibrate* tab. This tab is a debug utility that allows users to view, load, edit, and save EEPROM values

#### 4.10 Set-Up Cal Tab: Detailed Explanation

This section presents a detailed explanation of the Set-Up Cal tab (see Figure 18). One key element of this tab is the **Select Model File** button. Pressing this button allows you to select one of the model files. The model file defines critical calibration parameters such as output configuration, reference setting, output range, and calibration temperature range. The PGA309EVM software has several model files included that are representative of typical applications. You can use these files, edit them, or create new files. Once the appropriate model file is selected, the software is ready to start calibration (that is, you can move to the Auto after the Sensor Model File is selected).

Figure 21 shows a screenshot of the Set-Up Cal tab with the *Select Model File* button highlighted. Once this button is pressed, a dialog box appears that enables users to select a specific model file.

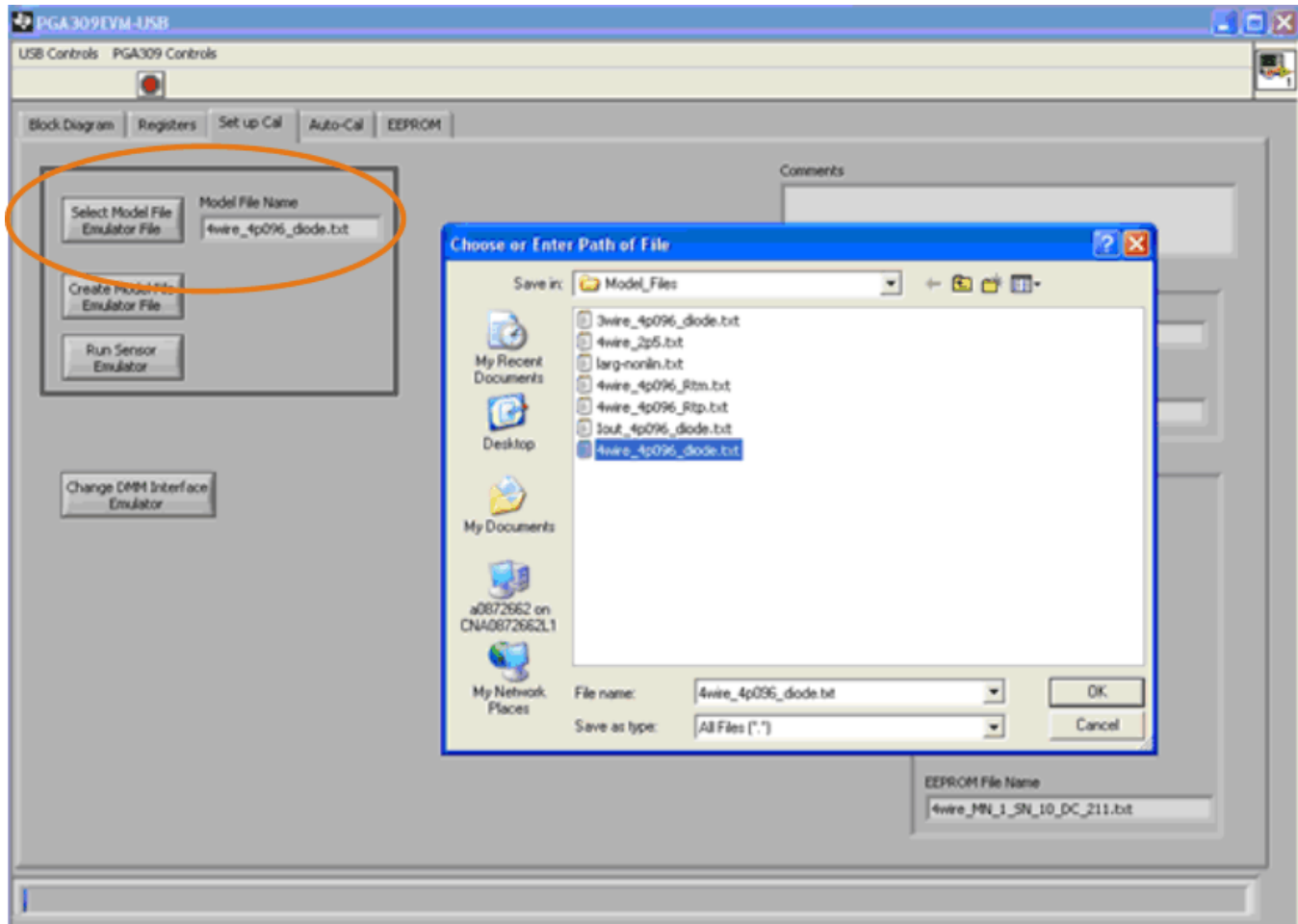
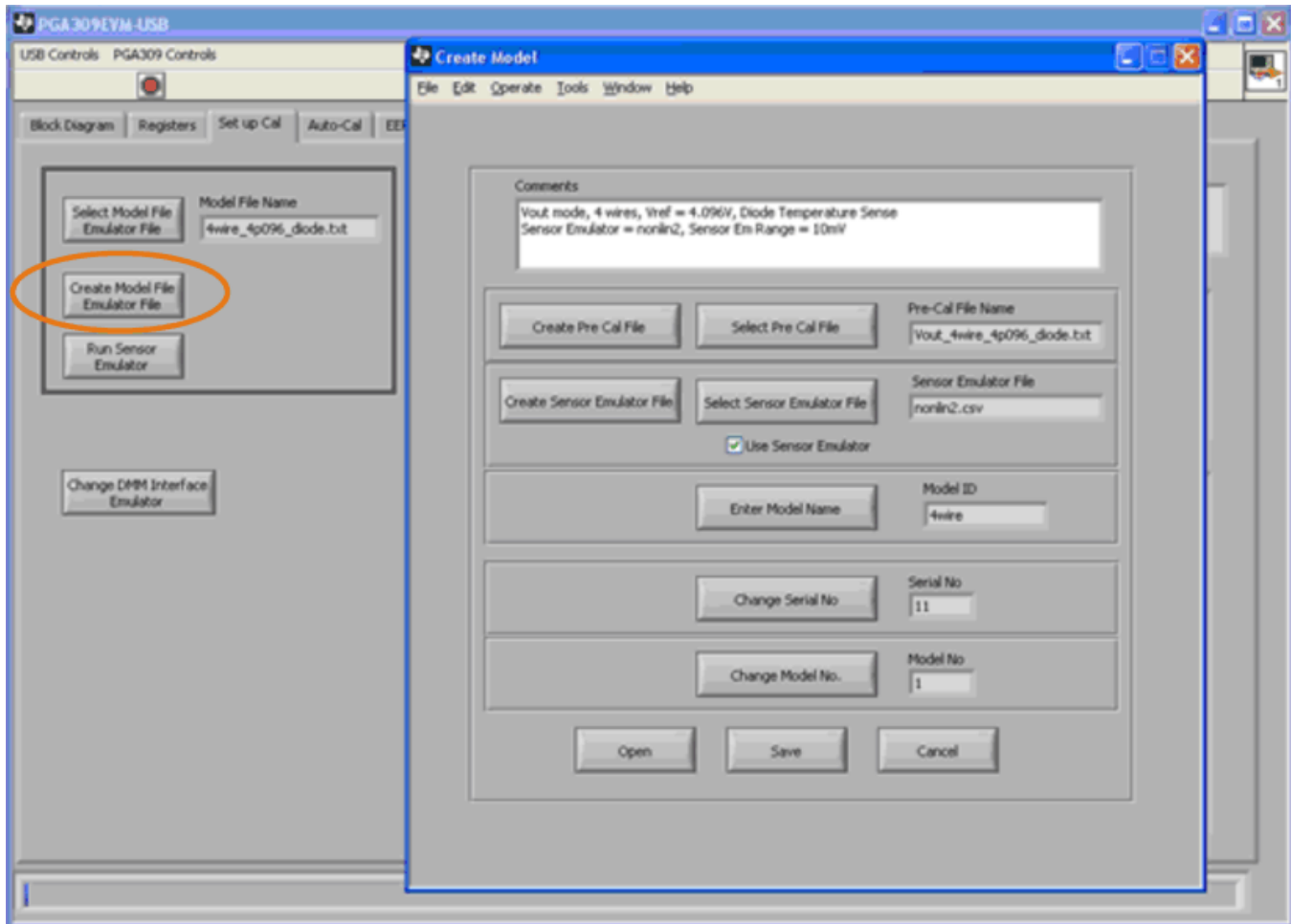

Figure 21. PGA309EVM-USB Software: Set-Up Cal Tab with Select Model File Dialog

When you want to edit a model file or create a new model file, you must first press the **Create Model File** button. Figure 22 shows the *Create Model* window that opens when the Create Model File button is pressed. The Create Model window allows users to choose the Pre-Cal File, Sensor Emulator File, Model ID, Serial Number, and Model Number that will be used during the calibration process. Each of these items is discussed in detail in the following sections.



**Figure 22. PGA309EVM-USB Software: Set-Up Cal Tab with Create Model Dialog**

The *Sensor Emulator Control Tool* window, as [Figure 23](#) illustrates, is a pop-up window that allows you to change the sensor emulator settings. It displays three graphs that show the operation of the emulated sensor for different pressures and temperatures. The two sliders below the graphs adjust the operating temperature and load of the emulated sensor. Making changes on this tool adjusts the sensor emulator output voltage so that it acts as if it were a real-world sensor. Using the sensor emulator is very helpful when learning how to do calibrations with the PGA309 because you do not have to wait for time-consuming temperature changes. The sensor emulator can also help to verify the accuracy of your electronics without sensor hysteresis and non-repeatability issues.

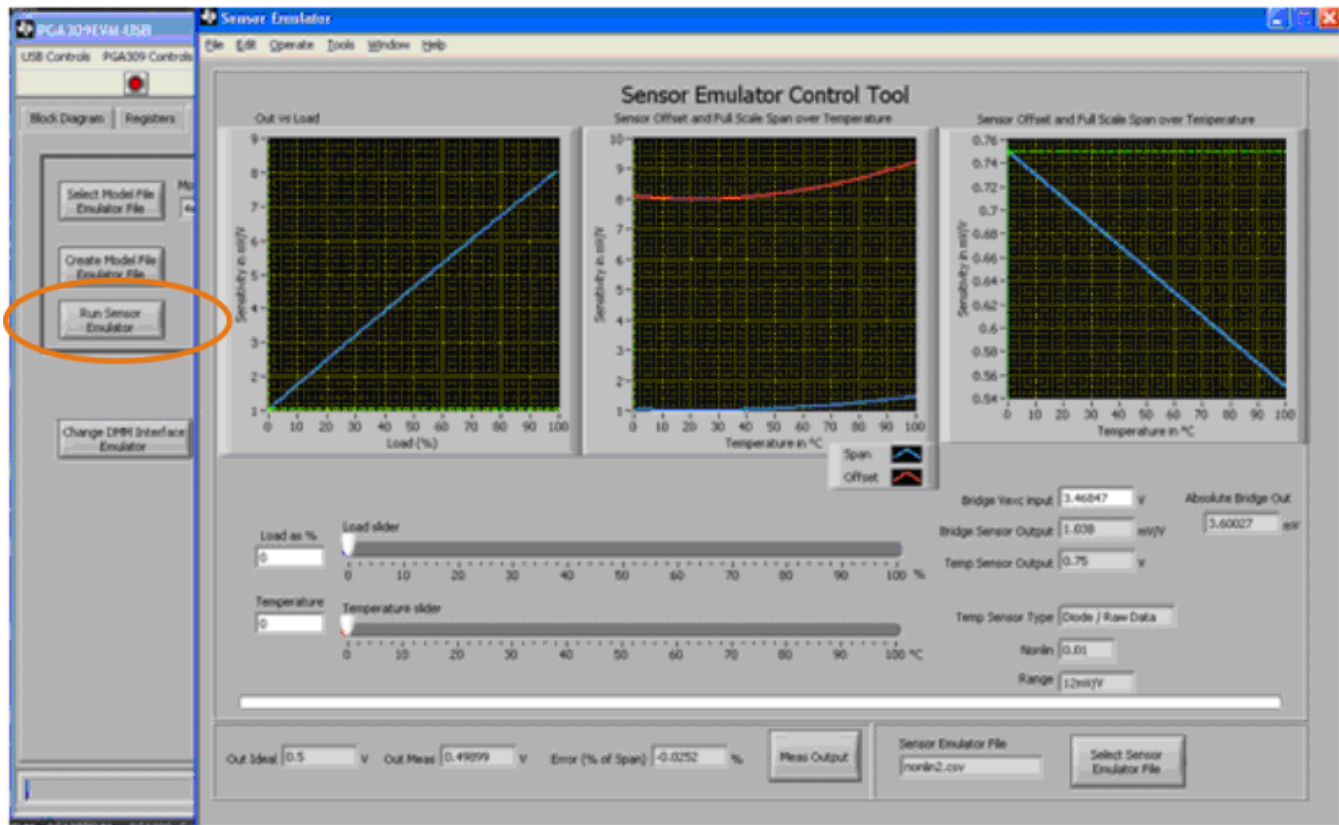
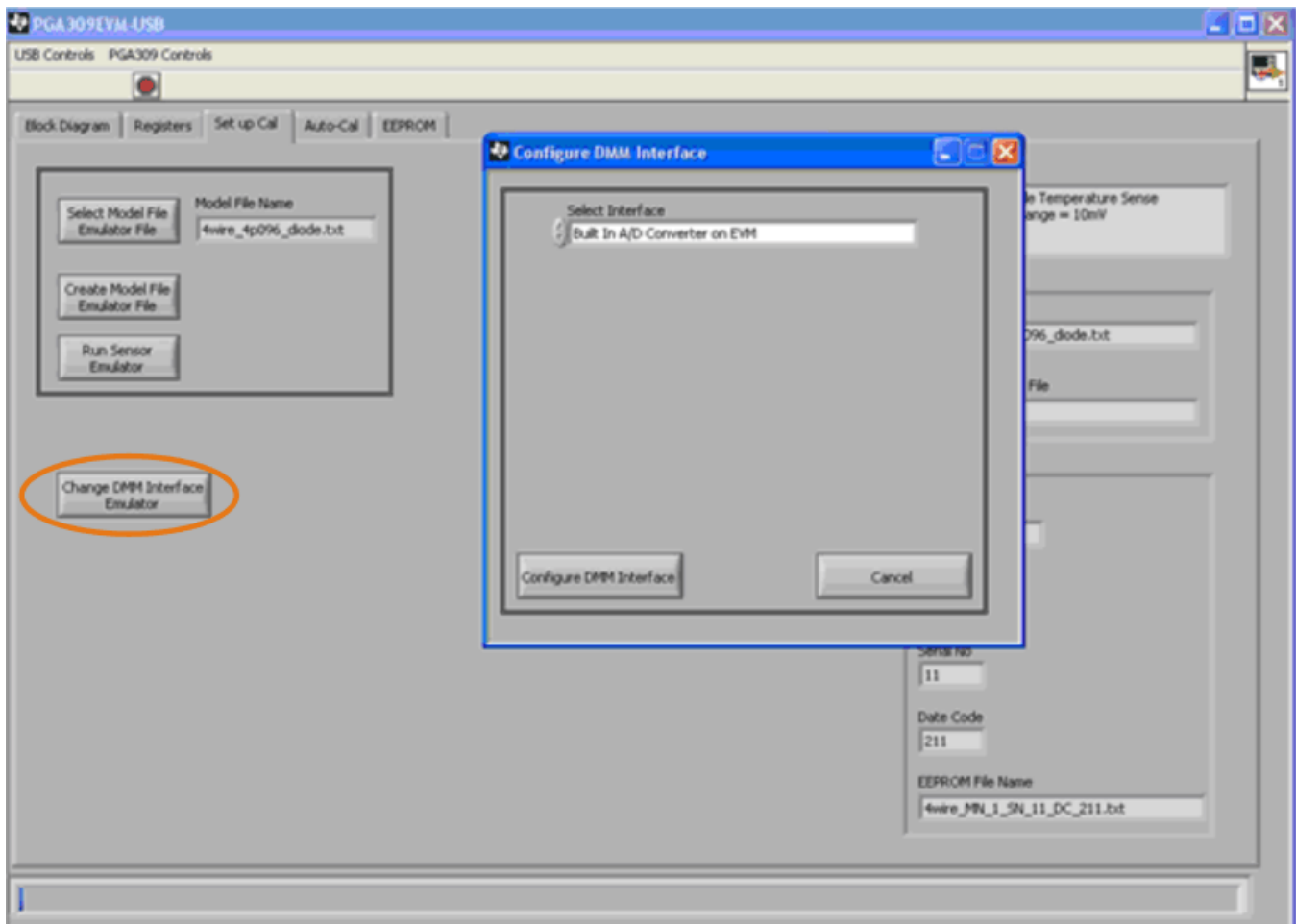

Figure 23. PGA309EVM-USB Software: Set-Up Cal Tab with Sensor Emulator Control Tool Dialog

The **Change DMM Interface** button is used to select the measurement resource for reading the voltage or current output of the PGA309. The PGA309EVM has an onboard ADC that can be used to perform all measurements. This ADC is convenient for initial evaluation because no additional equipment is required. For subsequent experiments, you may want to use a precision DMM to make measurements. The Agilent 34401A (not included with EVM kit) can be used to measure the voltage or current output of the PGA309. Communication with the Agilent 34401A can be managed using the computer serial port (RS-232) or the National Instruments' GPIB-USB-HS communications hardware.

The Configure DMM Interface utility pop-up dialog (as shown in [Figure 24](#)) allows you to select from one of these options:

- Built In A/D Converter on EVM
- RS-232 for 34401a
- GPIB-USB-HS for 34401a



**Figure 24. PGA309EVM-USB Software: Set-Up Cal Tab with Configure DMM Interface Dialog**

---

**NOTE:** If you use the RS-232 interface, you must configure the Agilent 34401a settings accordingly. If you have difficulty communicating with the instrument, make sure that the instrument is set to *RS-232*, and that the baud rate and parity match the software settings. If you are using the GPIB-USB-HS, make sure that the interface is set to *HP-IB / 488* and that the address matches the software setting.

---

### 4.11 Auto-Cal Tab: Detailed Description

The Auto-Cal tab is used to perform a fully-automated calibration of a PGA309 sensor module. This calibration can be done using either the sensor emulator or a real-world sensor module. If you use the sensor emulator, the EVM automatically adjusts the sensor emulator output throughout the calibration. When a real-world sensor is calibrated, the program pauses periodically and allows users to adjust the sensor stimulus (such as pressure) and temperature settings.

Calibration is initiated using the **Start** button (shown in Figure 25). The *Auto-Continue* feature can be used to allow calibration to continue without pausing. If the Auto-Continue checkbox is not selected, the software pauses after each calibration step to allow for manual adjustment of temperature or stimulus settings.

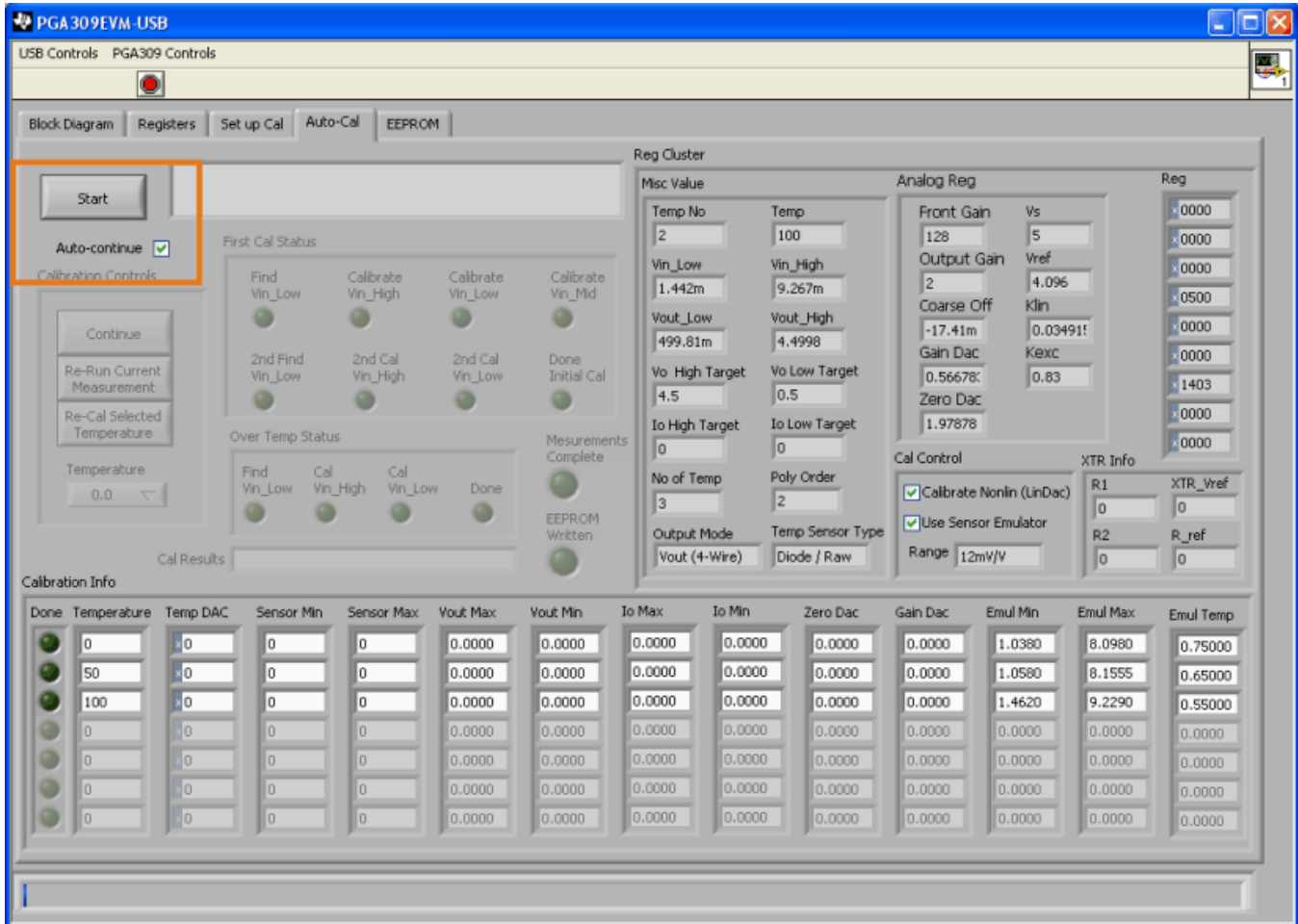

Figure 25. PGA309EVM-USB Software: Auto Calibrate Tab with Auto-Continue Feature Enabled

Figure 26 illustrates additional details of the Auto-Cal tab. Note that the **Continue** button blinks to indicate that the program is waiting for the user to adjust the stimulus or temperature settings; press the button to continue the calibration process. The *Calibration Info* section is the over-temperature data measured throughout the calibration. The *Reg Cluster* section contains the current register information that is measured.

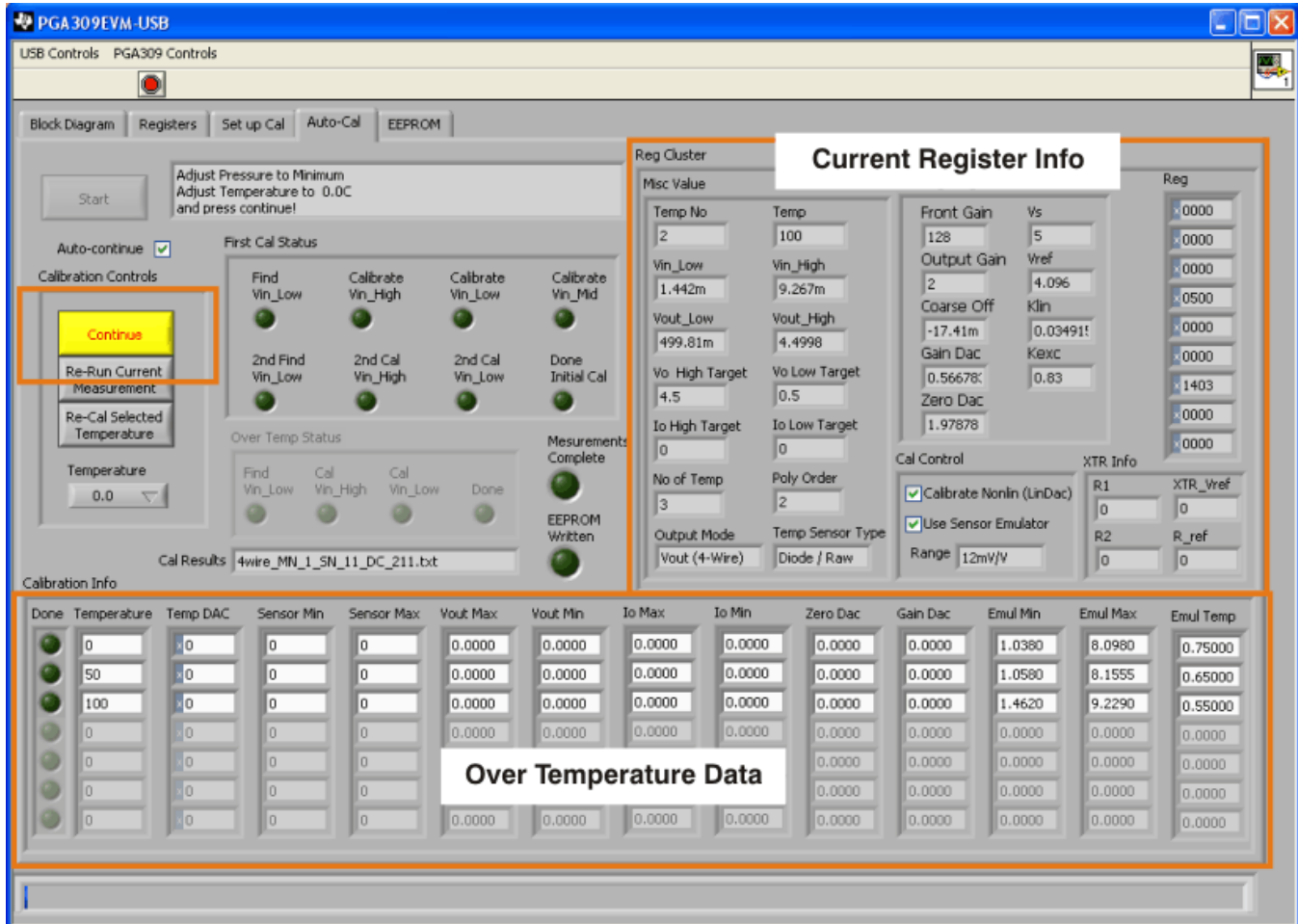

Figure 26. PGA309EVM-USB Software: Auto Calibrate Tab at Start of Calibration Process



Once a calibration is in progress, the display shows a screen similar to that in Figure 27.

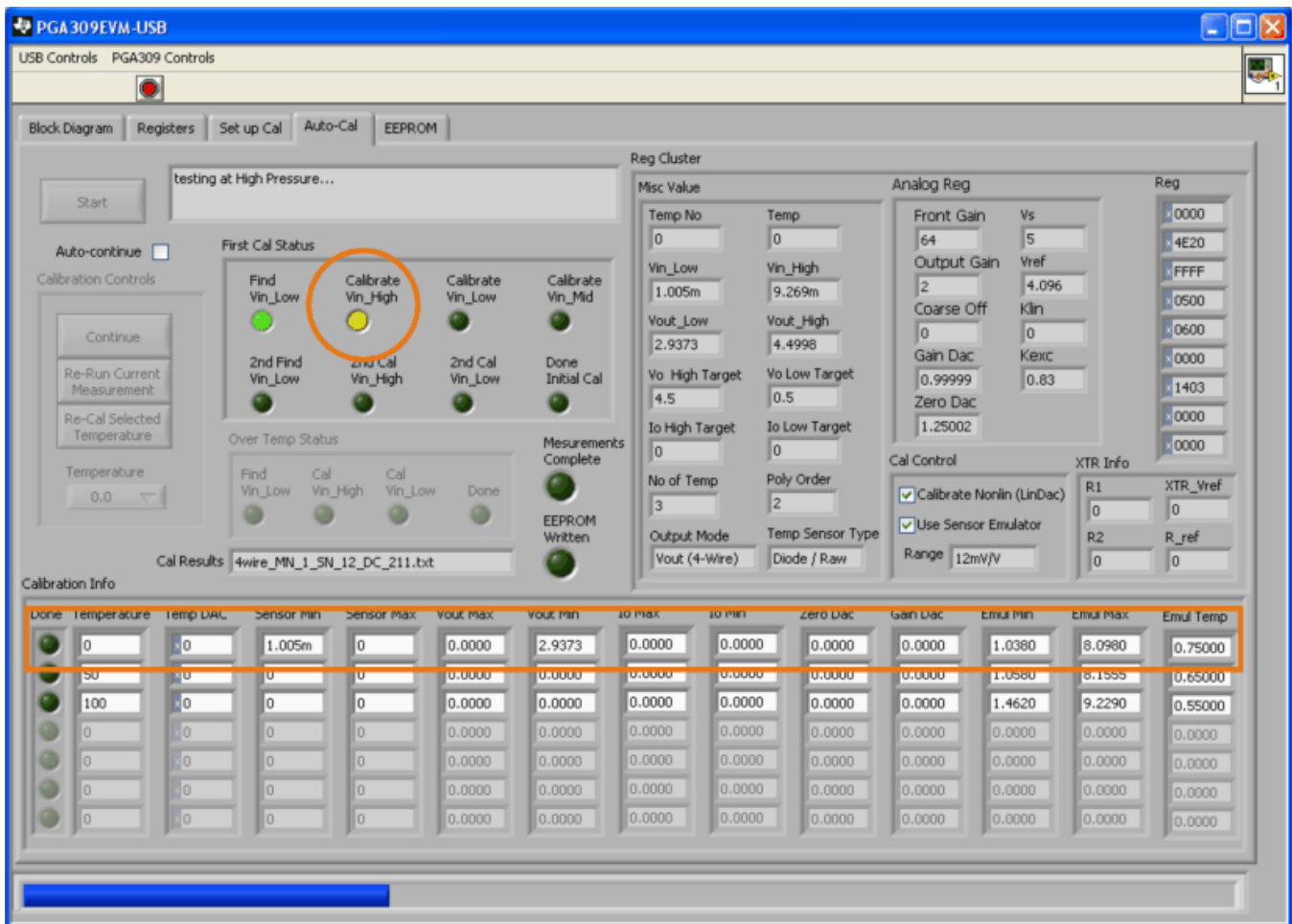

Figure 27. PGA309EVM-USB Software: Auto Calibrate Tab with Calibration in Progress

The progress of the calibration is shown using LED-style indicators. A green indicator means that the step is completed; a blinking indicator indicates that the step is currently in progress. In Figure 27, the Find Vin\_Low step is complete and the Calibrate Vin\_High step is in progress.

Figure 28 illustrates the Auto-Cal tab after the initial calibration completes and the second calibration has started. Note that all the LEDs in the *First Cal Status* section are green, and the entire section is shaded gray. The shading and green LED marking indicates that the first calibration process is complete. The first calibration includes additional steps (for example, selecting gains and adjusting the non-linearity correction) that are not required during later calibrations.

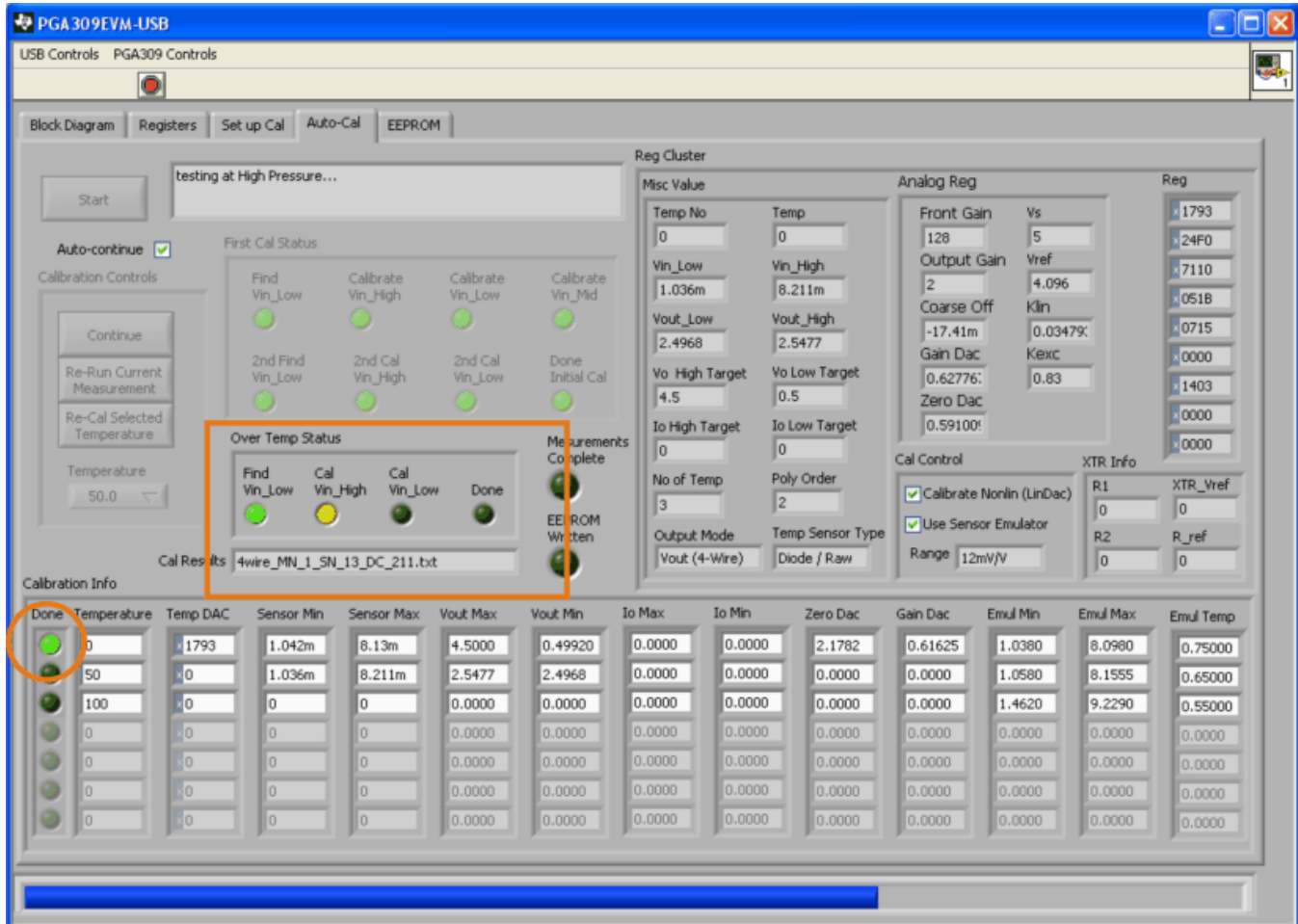

Figure 28. PGA309EVM-USB Software: Auto Calibrate Tab with Second Calibration in Progress

When the calibration is complete, the screen appears as shown in Figure 29. At this point, all of the over-temperature measurements have been completed, the EEPROM look-up table was created, and the look-up table was written to the EEPROM.

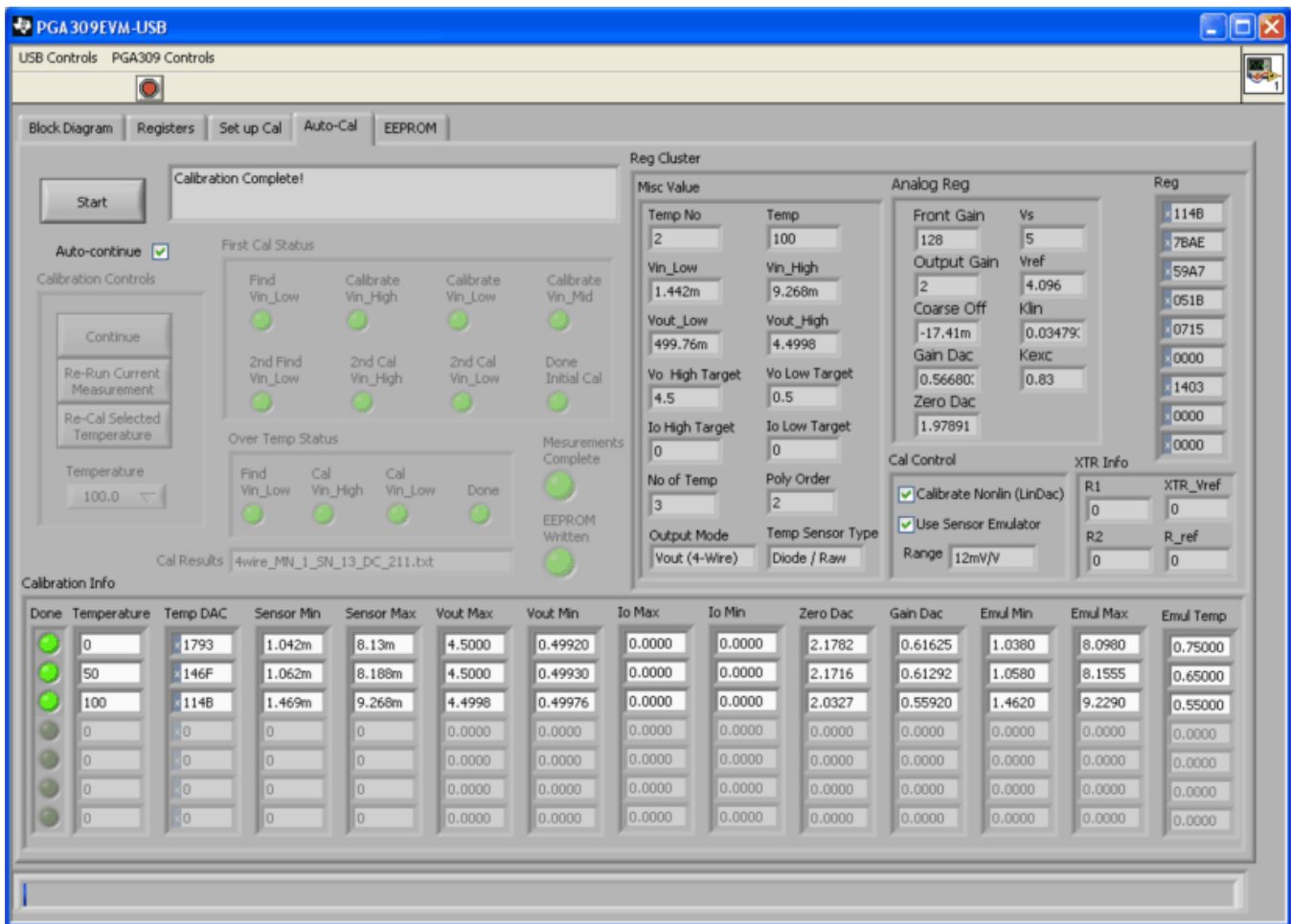
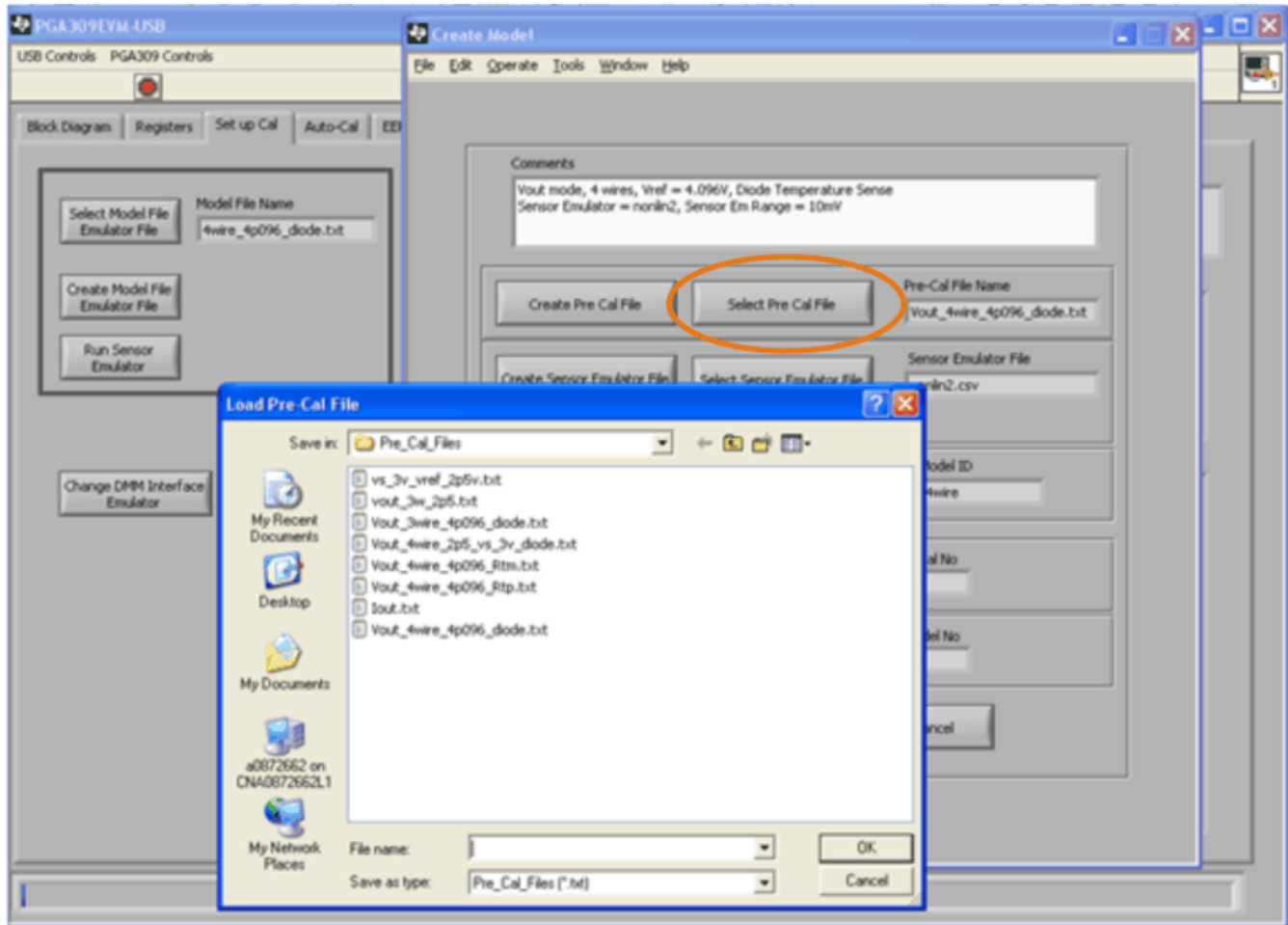

Figure 29. PGA309EVM-USB Software: Auto Calibrate Tab with Both Calibrations Complete

## 4.12 Create Model File: Detailed Discussion

One key file used during calibration is the *pre-cal* file. The pre-cal file defines the initial register settings, supply voltage, output range, output mode, and other key parameters required for the calibration.

When creating a new model file, users may either create a new pre-cal file or use an existing one if a file already exists that meets your requirements. Select a saved pre-cal file using the **Select Pre-Cal File** button. The *Load Pre-Cal* file dialog is displayed, as [Figure 30](#) shows.



**Figure 30. PGA309EVM-USB Software: Create Model, Select Pre-Cal File**

When creating a model file, it may be necessary to modify or create a new pre-cal file. Press the **Create Pre-Cal File** button to start this process. Figure 31 shows the utility that appears when you need to create a new pre-cal file. Details for editing a pre-cal file are covered in Section 4.13. The pre-cal file contains the initial register settings, power-supply settings, output modes, output ranges, and other pertinent settings.

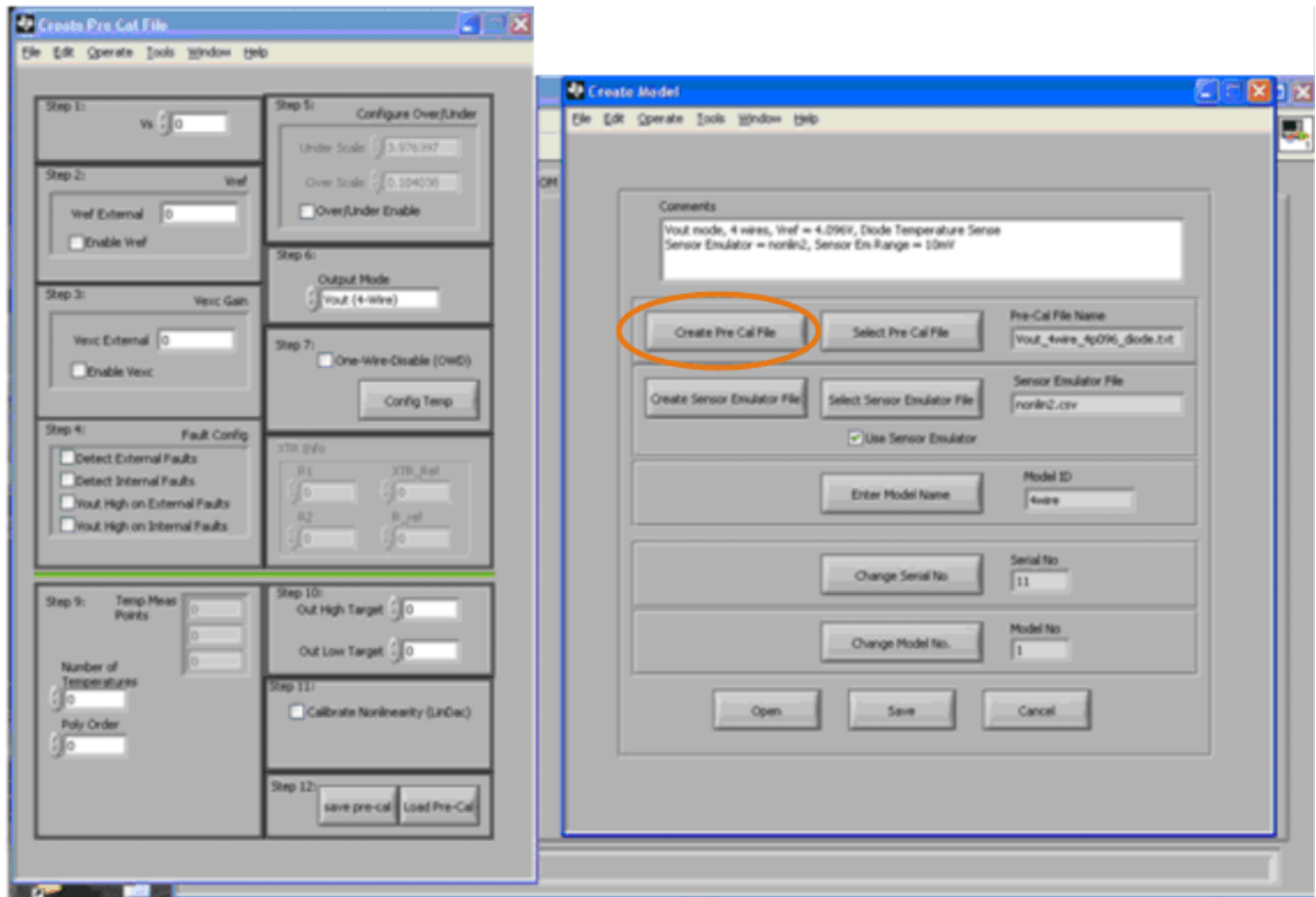

Figure 31. PGA309EVM-USB Software: Create Model Dialog with Create Pre-Cal File Active

The Sensor Emulator Control Tool is a pop-up window that can be accessed from the Sensor Definition tab, as Figure 32 shows. It displays three graphs that show the operation of the emulated sensor for different pressures and temperatures. The two sliders below the graphs adjust the operating limits.

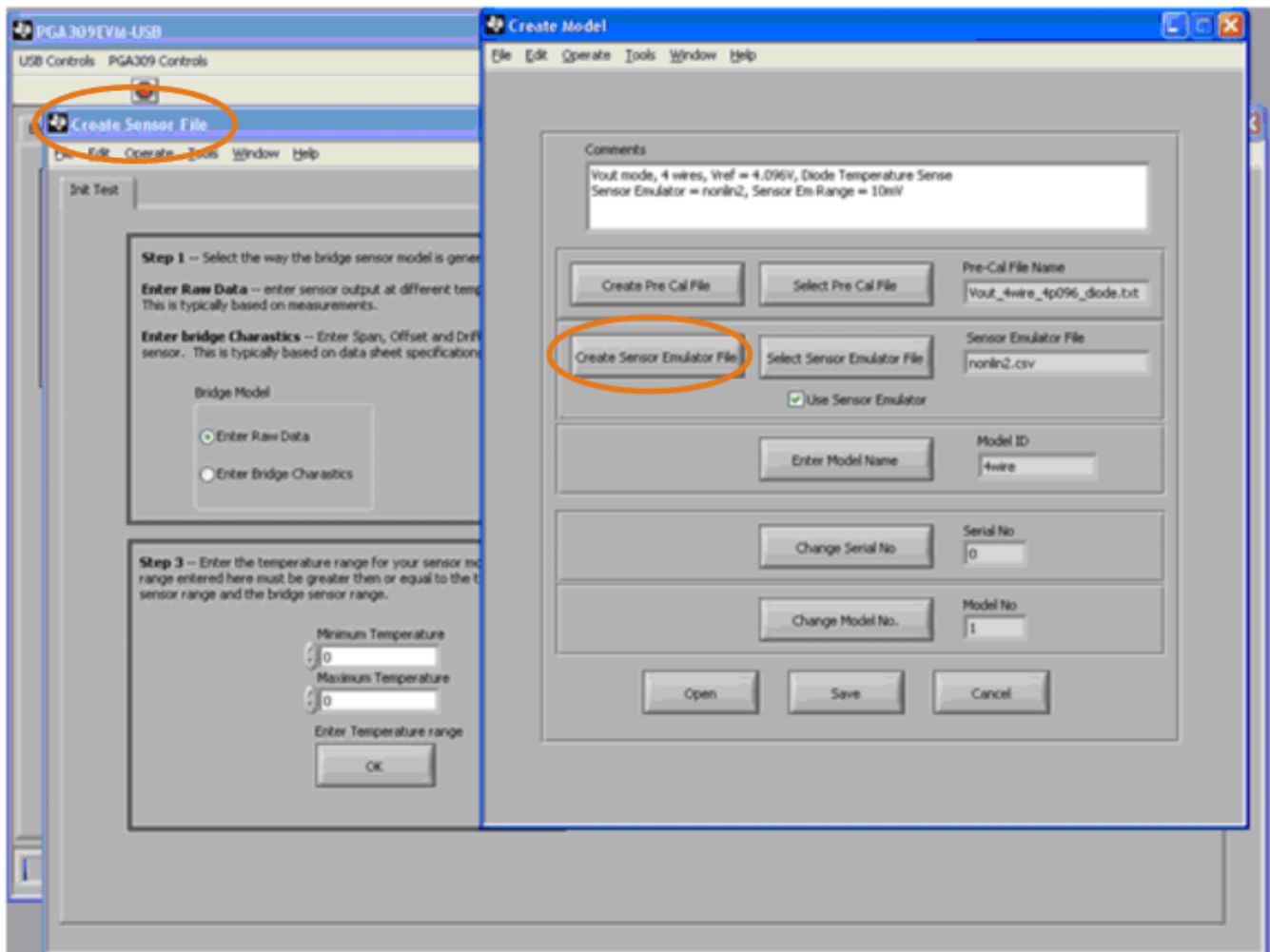
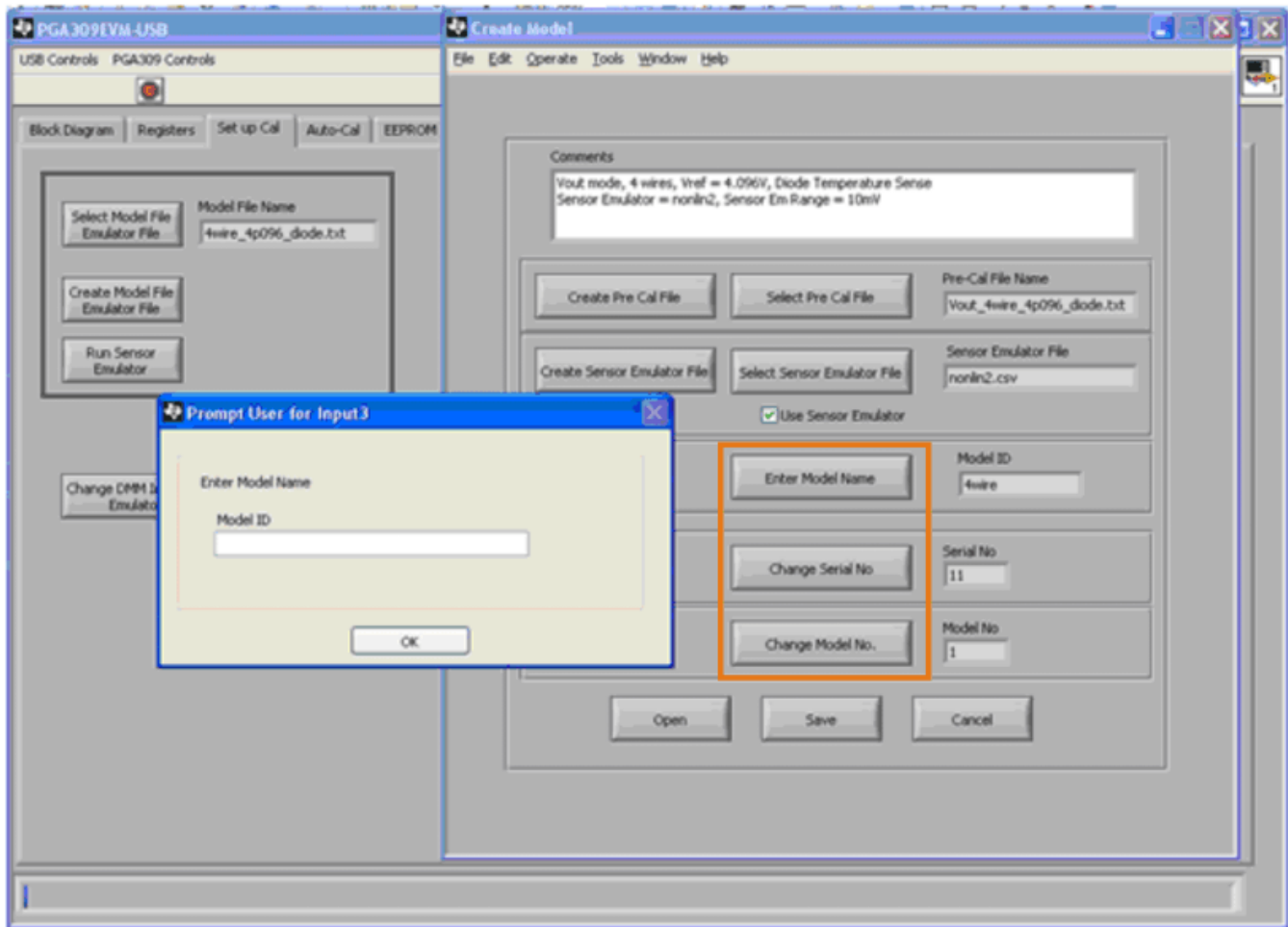

Figure 32. PGA309EVM-USB Software: Create Model Dialog with Create Sensor File Active

The model ID, serial number, and model number can be changed by pressing the three buttons highlighted in Figure 33. These numbers are used in the file name when data are stored at the end of each calibration.



**Figure 33. PGA309EVM-USB Software: Create Model Dialog with Model ID Active**

The file name structure is unique, and follows this pattern:

- File Name = 4wire\_MN\_1\_SN\_11\_DC\_0311.txt
- Model Name = 4wire
- Serial No = 11 (incremented automatically at the end of each calibration)
- Model number = 1
- Date code = 0311 (generated automatically by computer clock, week = 03, year = 11)

When the model file is completely edited, save the file by hitting the **Save** button, as indicated in Figure 34. If you wish to overwrite an older file, select an existing file name and then click **OK**.

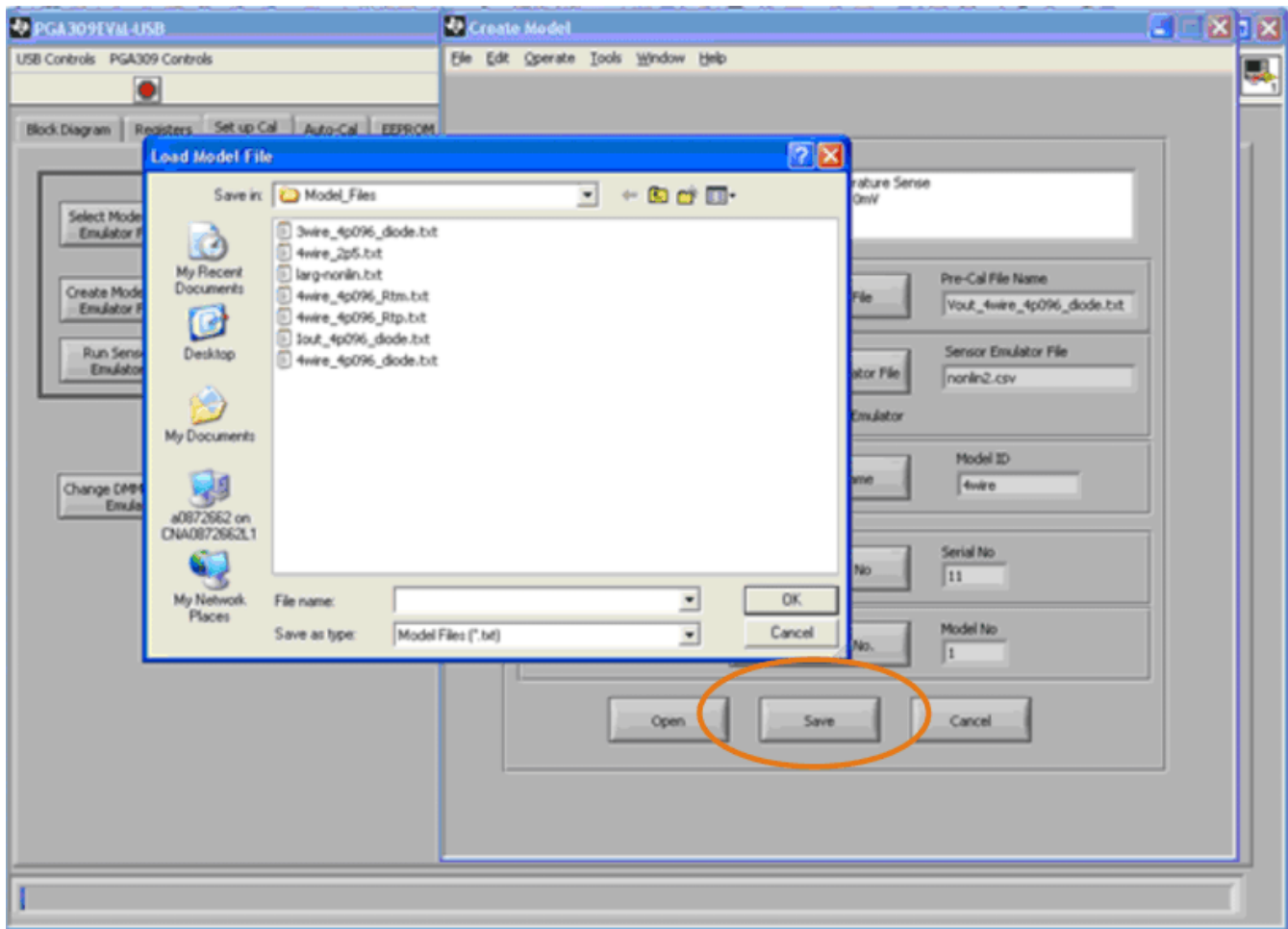

Figure 34. PGA309EVM-USB Software: Create Model Dialog with Save File Active



### 4.13 Create Pre-Cal File: Detailed Description

The Create Pre-Cal File is a utility that allows users to create a separate file with all of the initial register settings, power-supply voltages, output configurations, and other relevant requirements. The Create Pre-Cal File window, illustrated in Figure 35, has 12 fields labeled Step 1 to Step 12. It is recommended that you edit the 12 fields in sequential order because some of the fields depend on inputs to previous fields. Each of the 12 fields are described in Table 8.

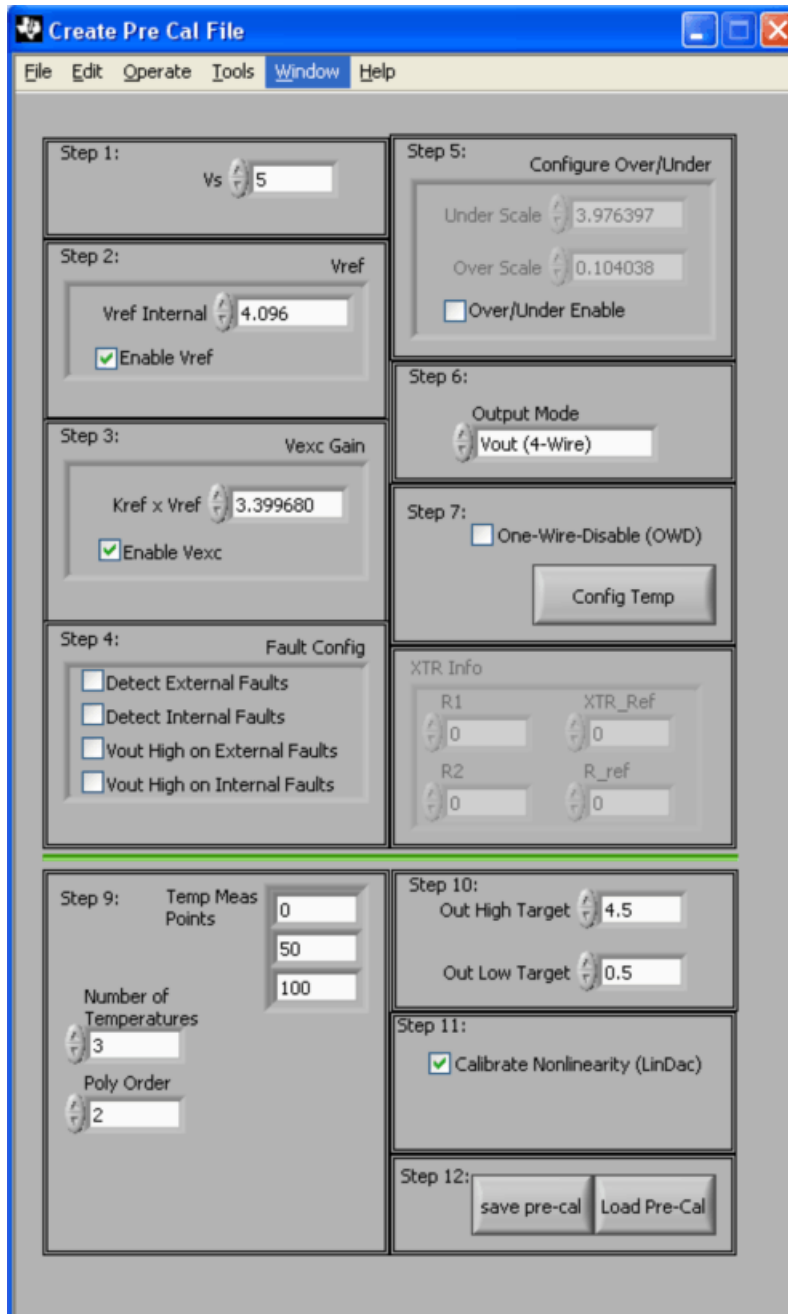

Figure 35. PGA309EVM-USB Software: Create Pre-Cal File Dialog with Sensor Emulator Control Tool

**Table 8. Create Pre-Cal File Field Descriptions**

Step No	Description
1: Vs	Sets the PGA309 power-supply voltage to be used.
2: Vref	Selects different internal references or allows for external reference
3: Vexc	Selects the $V_{EXC}$ value or disables $V_{EXC}$
4: Fault Config	Enables fault configuration. If fault detection is used, it is disabled during calibration and enabled at the end of calibration.
5: Configure Over / Under	Allows users to set an over-scale or under-scale limit or disable the limit. This feature is disabled during calibration and enabled at the end of the calibration.
6: Output Mode	Allows users to select between the three different PGA309 output modes (3-wire $V_{OUT}$ , 4-wire $V_{OUT}$ , and $I_{OUT}$ ).
7: One-Wire Disable and Configure Temperature	<i>One-wire disable</i> is typically used in conjunction with 3-wire $V_{OUT}$ mode. This feature is described in detail in the PGA309 device user's guide. Press <i>Configure Temperature</i> to set up the temperature sensor for the PGA309. This feature is described in detail in section xx of this document.
8: XTR Info	This section is only active when current loop mode is used.
9: Temperature List for Cal	This section allows users to select the number of temperatures in the calibration and the temperature values. A typical calibration includes three temperatures. Additional temperatures can be added for more accuracy.
10: Output Targets	This section lets users set the post-calibration targets for the output voltage or current. For voltage output, typical targets are 0.5 to 4.5. For current output, typical targets are 0.004 to 0.02.
11: Calibrate Nonlinearity	This section allows users to calibrate nonlinearity versus stimulus. If your sensor does not have nonlinearity versus stimulus issues, you can skip this calibration step.
12: Save or Load Files	When you have finished editing the pre-cal file, you can either save the file or load the file to the EVM.

#### 4.14 Create Sensor Emulator File: Detailed Discussion

The *Create Sensor File* utility enables users to create a sensor data file for the sensor emulator tool in order to generate signals that emulate the behavior of a real-world sensor. This utility requires a multi-step process to create a sensor emulator file. [Figure 36](#) shows the first three steps in the process.

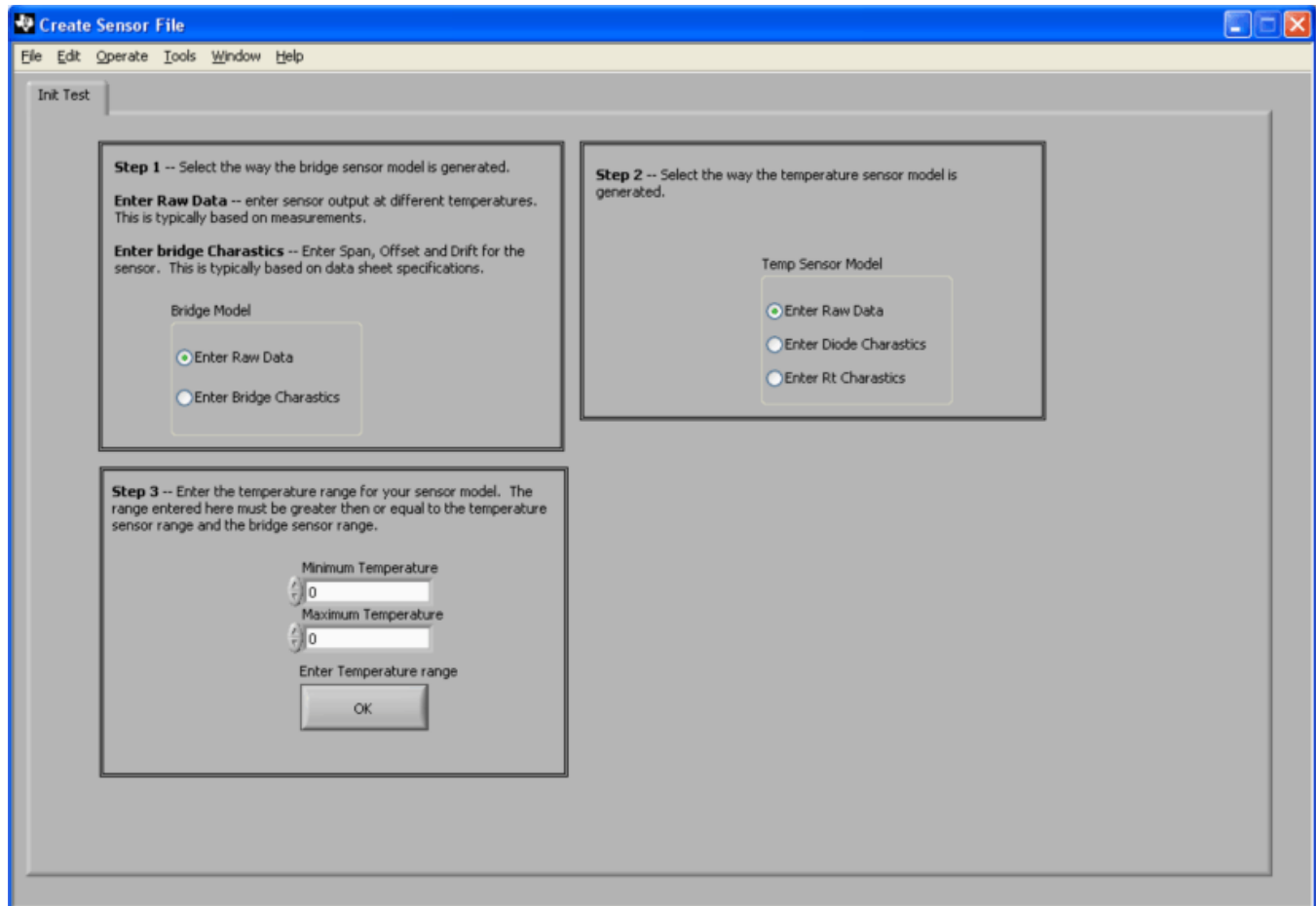

**Figure 36. PGA309EVM-USB Software: Create Sensor Emulator File**

Step 1. Select the way that data are entered for the model.

The most common way is to enter raw data. Raw data can either be measured sensor data or values input from a product data sheet. Raw data are given as sensor outputs at specific temperatures. A second way to enter the sensor data is to select the *Enter Bridge Characteristics* option. When using this option, you must also enter the drift and offset numbers in ppm/°C directly from the data sheet.

Step 2. Specify the type of temperature sensor used (diode, RT, or raw).

Note that you cannot use the emulator for the internal temperature sensor mode of operation. For both the diode and Rt methods, the emulator generates an input signal that matches the real-world equivalent. The raw data option for the temperature sensor allows you to enter any arbitrary voltage vs temperature data. This option could be used for unique temperature sensor signals (for example, not the diode or Rt methods).

Step 3. Enter the temperature range for the sensor emulator function to operate in.

After the temperature range is entered, additional tabs appear that must be completed; these tabs are noted in [Figure 37](#).

Figure 37 the additional tabs that appear after the *Enter Temperature Range* button is pressed. Note that the tabs correspond to the options selected in Step 1 and Step 2. You must provide the information requested on each tab and then save the sensor emulator file before proceeding to use it.

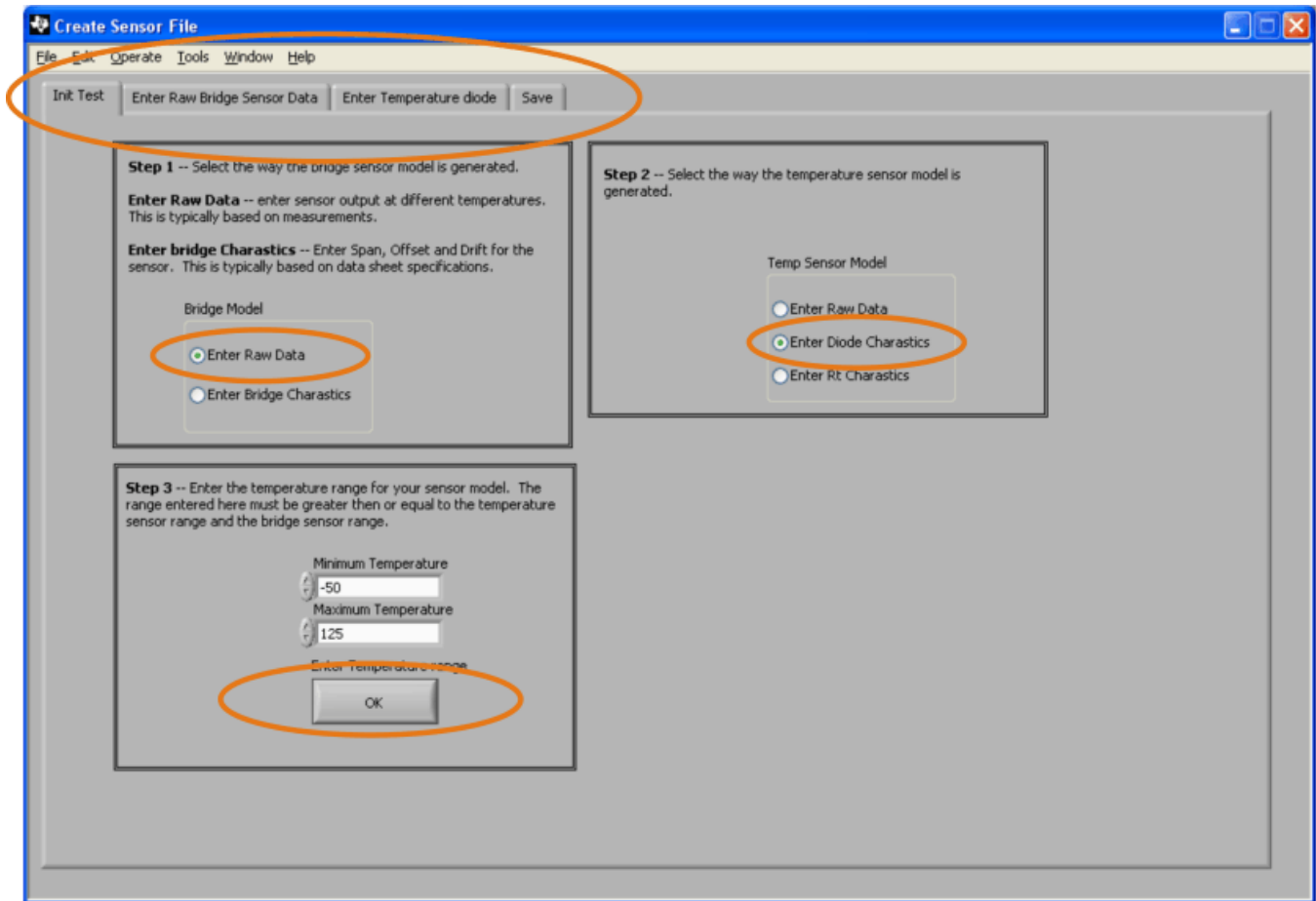

Figure 37. PGA309EVM-USB Software: Create Sensor Emulator File with Additional Tabs

Figure 38 illustrates the tab for entering raw bridge sensor data. This tab appears after the temperature range is set on the first tab

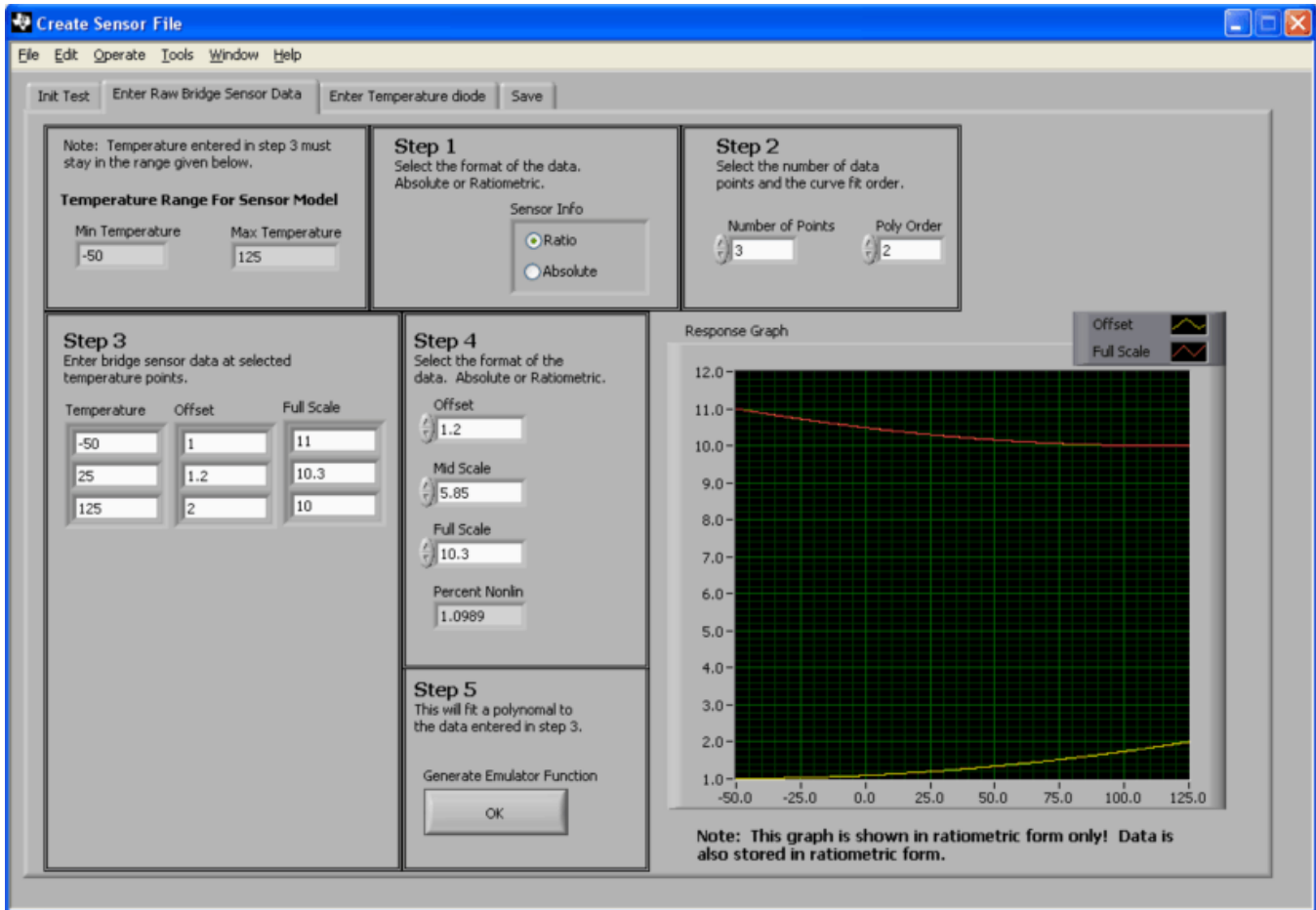

Figure 38. PGA309EVM-USB Software: Create Sensor Emulator File by Entering Raw Bridge Sensor Data

In this example, bridge sensor drift information is loaded by entering the sensor raw data. There are five steps to this process.

Step 1. Choose the data format (absolute or ratiometric sensor output).

Ratiometric output is the most common way to enter sensor data. Ratiometric sensor data are entered in mV/V. For absolute data, you must enter the sensor data in mV and the sensor excitation voltage in V.

Step 2. Enter the number of temperature points and the curve fit polynomial order.

As you adjust the data in Step 2, the size of the table in Step 3 adjusts accordingly.

Step 3. Enter the bridge sensor data at selected temperature points.

This step is performed automatically as you adjust the data in Step 2. You can also make changes to the data points in this step.

Step 4. Enter the nonlinearity data.

These data can be measured at any temperature. The mid-scale point computes the Percent Nonlinearity value displayed.

Step 5. Press the button to generate the emulator function.

Once the button is pressed, a chart that describes the over-temperature drift is displayed.

The next step in the process of generating a sensor emulator file is to enter the temperature sensor data. The example shown in [Figure 39](#) uses diode temperature data.

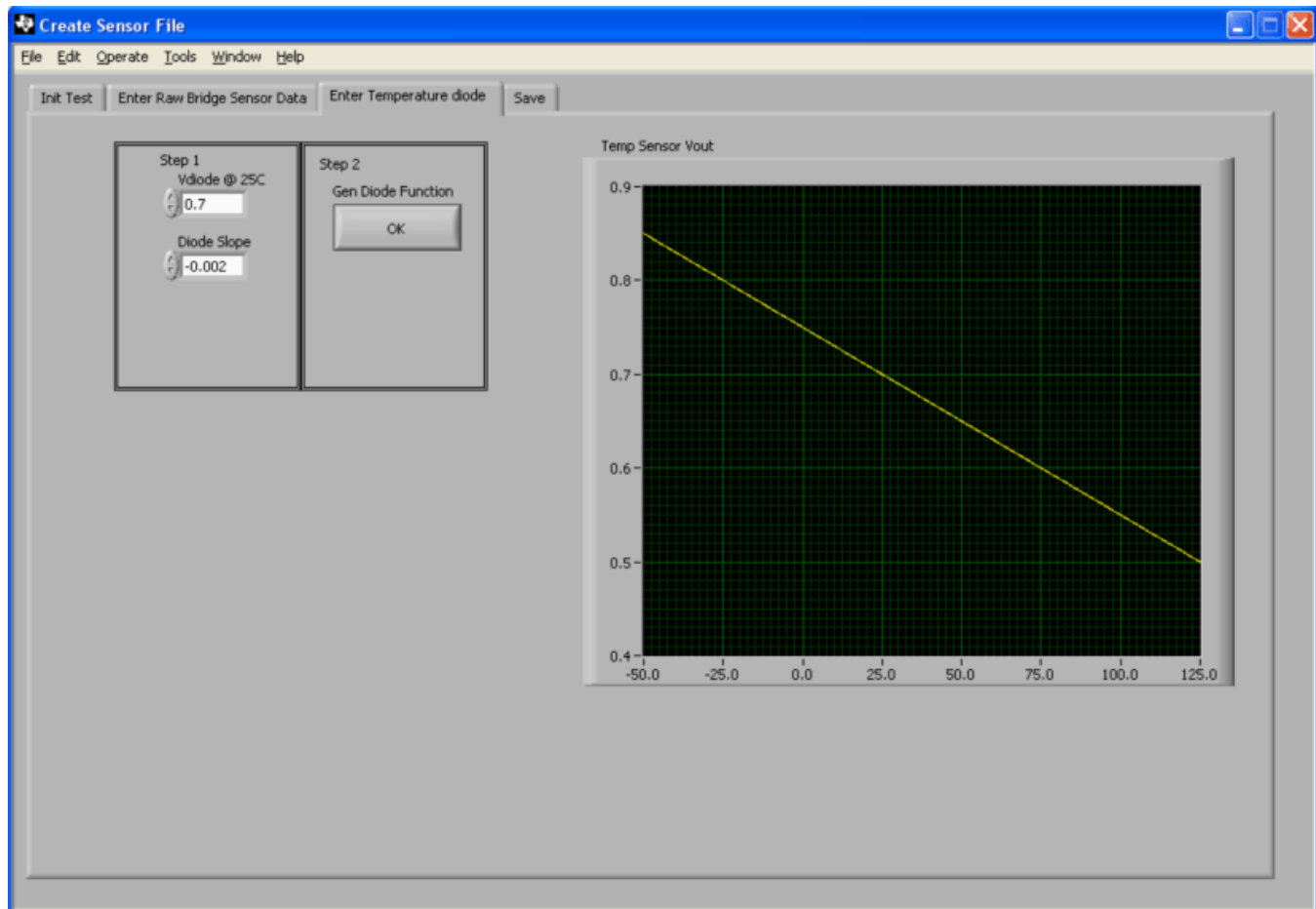

**Figure 39. PGA309EVM-USB Software: Create Sensor Emulator File by Entering Temperature Data**

There are two steps to this process.

Step 1. Set the diode voltage and the slope.

Enter the diode voltage at +25°C and the diode slope (typically  $-2\text{mV}/^\circ\text{C}$ ).

Step 2. Press the Gen Diode Function **OK** button.

Press the button to complete this function.

The final step in the process of generating a sensor emulator file is to save the file. Figure 40 illustrates the Save tab. Note that the temperature function and sensor over temperature data are displayed for review.

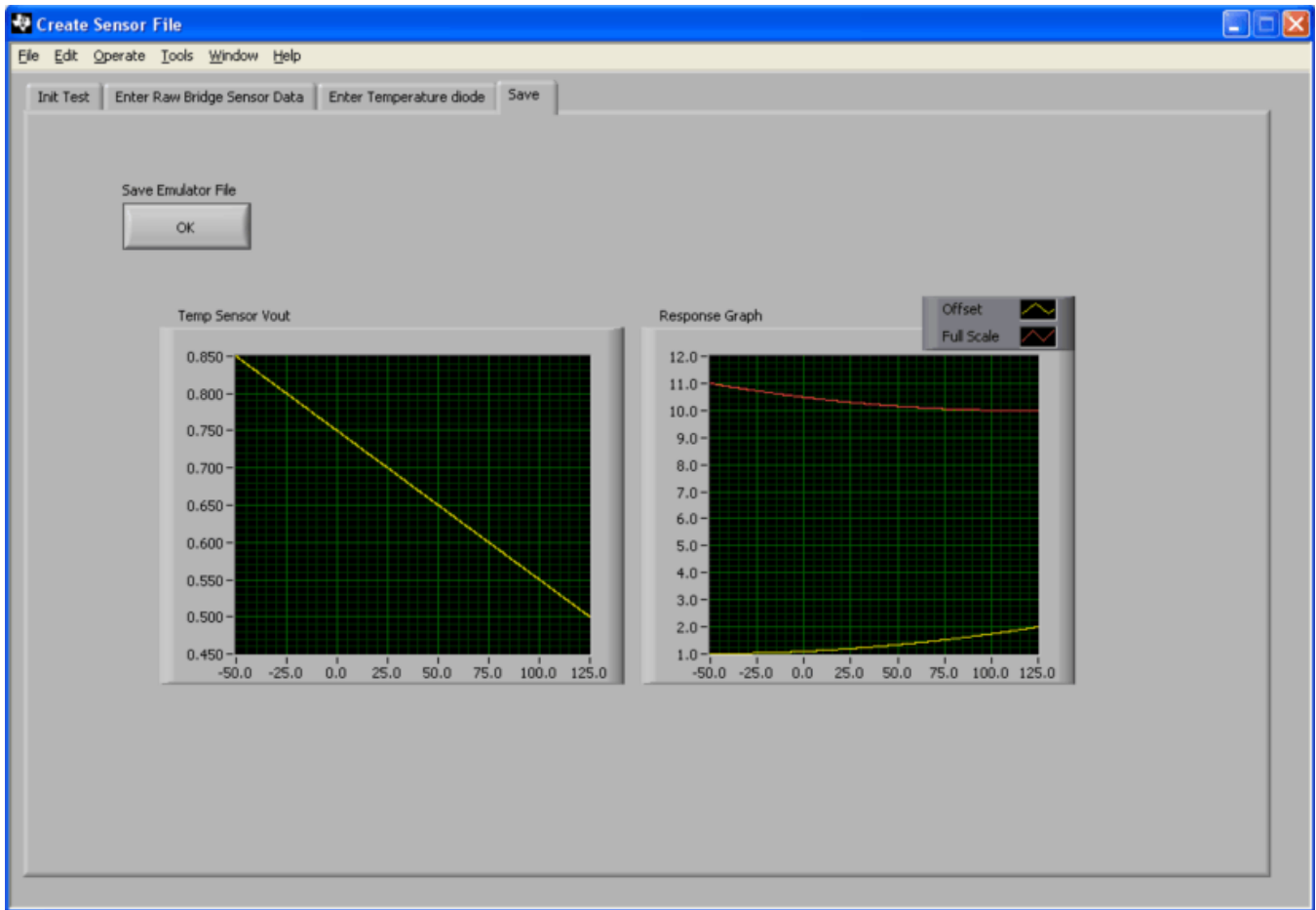

Figure 40. PGA309EVM-USB Software: Save a Created Sensor Emulator File

## Revision History

**Changes from Original (February, 2010) to A Revision** **Page**

---

- Revised [Section 4](#) ..... **25**
- 

NOTE: Page numbers for previous revisions may differ from page numbers in the current version.



## Evaluation Board/Kit Important Notice

Texas Instruments (TI) provides the enclosed product(s) under the following conditions:

This evaluation board/kit is intended for use for **ENGINEERING DEVELOPMENT, DEMONSTRATION, OR EVALUATION PURPOSES ONLY** and is not considered by TI to be a finished end-product fit for general consumer use. Persons handling the product(s) must have electronics training and observe good engineering practice standards. As such, the goods being provided are not intended to be complete in terms of required design-, marketing-, and/or manufacturing-related protective considerations, including product safety and environmental measures typically found in end products that incorporate such semiconductor components or circuit boards. This evaluation board/kit does not fall within the scope of the European Union directives regarding electromagnetic compatibility, restricted substances (RoHS), recycling (WEEE), FCC, CE or UL, and therefore may not meet the technical requirements of these directives or other related directives.

Should this evaluation board/kit not meet the specifications indicated in the User's Guide, the board/kit may be returned within 30 days from the date of delivery for a full refund. **THE FOREGOING WARRANTY IS THE EXCLUSIVE WARRANTY MADE BY SELLER TO BUYER AND IS IN LIEU OF ALL OTHER WARRANTIES, EXPRESSED, IMPLIED, OR STATUTORY, INCLUDING ANY WARRANTY OF MERCHANTABILITY OR FITNESS FOR ANY PARTICULAR PURPOSE.**

The user assumes all responsibility and liability for proper and safe handling of the goods. Further, the user indemnifies TI from all claims arising from the handling or use of the goods. Due to the open construction of the product, it is the user's responsibility to take any and all appropriate precautions with regard to electrostatic discharge.

**EXCEPT TO THE EXTENT OF THE INDEMNITY SET FORTH ABOVE, NEITHER PARTY SHALL BE LIABLE TO THE OTHER FOR ANY INDIRECT, SPECIAL, INCIDENTAL, OR CONSEQUENTIAL DAMAGES.**

TI currently deals with a variety of customers for products, and therefore our arrangement with the user **is not exclusive.**

TI assumes **no liability for applications assistance, customer product design, software performance, or infringement of patents or services described herein.**

Please read the User's Guide and, specifically, the Warnings and Restrictions notice in the User's Guide prior to handling the product. This notice contains important safety information about temperatures and voltages. For additional information on TI's environmental and/or safety programs, please contact the TI application engineer or visit [www.ti.com/esh](http://www.ti.com/esh).

No license is granted under any patent right or other intellectual property right of TI covering or relating to any machine, process, or combination in which such TI products or services might be or are used.

## FCC Warning

This evaluation board/kit is intended for use for **ENGINEERING DEVELOPMENT, DEMONSTRATION, OR EVALUATION PURPOSES ONLY** and is not considered by TI to be a finished end-product fit for general consumer use. It generates, uses, and can radiate radio frequency energy and has not been tested for compliance with the limits of computing devices pursuant to part 15 of FCC rules, which are designed to provide reasonable protection against radio frequency interference. Operation of this equipment in other environments may cause interference with radio communications, in which case the user at his own expense will be required to take whatever measures may be required to correct this interference.

## EVM Warnings and Restrictions

It is important to operate this EVM within the input voltage range of 5.7V to 9V and the output voltage range of 0V to 5V.

Exceeding the specified input range may cause unexpected operation and/or irreversible damage to the EVM. If there are questions concerning the input range, please contact a TI field representative prior to connecting the input power.

Applying loads outside of the specified output range may result in unintended operation and/or possible permanent damage to the EVM. Please consult the EVM User's Guide prior to connecting any load to the EVM output. If there is uncertainty as to the load specification, please contact a TI field representative.

During normal operation, some circuit components may have case temperatures greater than +50°C. The EVM is designed to operate properly with certain components above +125°C as long as the input and output ranges are maintained. These components include but are not limited to linear regulators, switching transistors, pass transistors, and current sense resistors. These types of devices can be identified using the EVM schematic located in the EVM User's Guide. When placing measurement probes near these devices during operation, please be aware that these devices may be very warm to the touch.

Mailing Address: Texas Instruments, Post Office Box 655303, Dallas, Texas 75265  
Copyright © 2011, Texas Instruments Incorporated

## IMPORTANT NOTICE

Texas Instruments Incorporated and its subsidiaries (TI) reserve the right to make corrections, modifications, enhancements, improvements, and other changes to its products and services at any time and to discontinue any product or service without notice. Customers should obtain the latest relevant information before placing orders and should verify that such information is current and complete. All products are sold subject to TI's terms and conditions of sale supplied at the time of order acknowledgment.

TI warrants performance of its hardware products to the specifications applicable at the time of sale in accordance with TI's standard warranty. Testing and other quality control techniques are used to the extent TI deems necessary to support this warranty. Except where mandated by government requirements, testing of all parameters of each product is not necessarily performed.

TI assumes no liability for applications assistance or customer product design. Customers are responsible for their products and applications using TI components. To minimize the risks associated with customer products and applications, customers should provide adequate design and operating safeguards.

TI does not warrant or represent that any license, either express or implied, is granted under any TI patent right, copyright, mask work right, or other TI intellectual property right relating to any combination, machine, or process in which TI products or services are used. Information published by TI regarding third-party products or services does not constitute a license from TI to use such products or services or a warranty or endorsement thereof. Use of such information may require a license from a third party under the patents or other intellectual property of the third party, or a license from TI under the patents or other intellectual property of TI.

Reproduction of TI information in TI data books or data sheets is permissible only if reproduction is without alteration and is accompanied by all associated warranties, conditions, limitations, and notices. Reproduction of this information with alteration is an unfair and deceptive business practice. TI is not responsible or liable for such altered documentation. Information of third parties may be subject to additional restrictions.

Resale of TI products or services with statements different from or beyond the parameters stated by TI for that product or service voids all express and any implied warranties for the associated TI product or service and is an unfair and deceptive business practice. TI is not responsible or liable for any such statements.

TI products are not authorized for use in safety-critical applications (such as life support) where a failure of the TI product would reasonably be expected to cause severe personal injury or death, unless officers of the parties have executed an agreement specifically governing such use. Buyers represent that they have all necessary expertise in the safety and regulatory ramifications of their applications, and acknowledge and agree that they are solely responsible for all legal, regulatory and safety-related requirements concerning their products and any use of TI products in such safety-critical applications, notwithstanding any applications-related information or support that may be provided by TI. Further, Buyers must fully indemnify TI and its representatives against any damages arising out of the use of TI products in such safety-critical applications.

TI products are neither designed nor intended for use in military/aerospace applications or environments unless the TI products are specifically designated by TI as military-grade or "enhanced plastic." Only products designated by TI as military-grade meet military specifications. Buyers acknowledge and agree that any such use of TI products which TI has not designated as military-grade is solely at the Buyer's risk, and that they are solely responsible for compliance with all legal and regulatory requirements in connection with such use.

TI products are neither designed nor intended for use in automotive applications or environments unless the specific TI products are designated by TI as compliant with ISO/TS 16949 requirements. Buyers acknowledge and agree that, if they use any non-designated products in automotive applications, TI will not be responsible for any failure to meet such requirements.

Following are URLs where you can obtain information on other Texas Instruments products and application solutions:

### Products

Audio	<a href="http://www.ti.com/audio">www.ti.com/audio</a>
Amplifiers	<a href="http://amplifier.ti.com">amplifier.ti.com</a>
Data Converters	<a href="http://dataconverter.ti.com">dataconverter.ti.com</a>
DLP® Products	<a href="http://www.dlp.com">www.dlp.com</a>
DSP	<a href="http://dsp.ti.com">dsp.ti.com</a>
Clocks and Timers	<a href="http://www.ti.com/clocks">www.ti.com/clocks</a>
Interface	<a href="http://interface.ti.com">interface.ti.com</a>
Logic	<a href="http://logic.ti.com">logic.ti.com</a>
Power Mgmt	<a href="http://power.ti.com">power.ti.com</a>
Microcontrollers	<a href="http://microcontroller.ti.com">microcontroller.ti.com</a>
RFID	<a href="http://www.ti-rfid.com">www.ti-rfid.com</a>
RF/IF and ZigBee® Solutions	<a href="http://www.ti.com/lprf">www.ti.com/lprf</a>

### Applications

Communications and Telecom	<a href="http://www.ti.com/communications">www.ti.com/communications</a>
Computers and Peripherals	<a href="http://www.ti.com/computers">www.ti.com/computers</a>
Consumer Electronics	<a href="http://www.ti.com/consumer-apps">www.ti.com/consumer-apps</a>
Energy and Lighting	<a href="http://www.ti.com/energy">www.ti.com/energy</a>
Industrial	<a href="http://www.ti.com/industrial">www.ti.com/industrial</a>
Medical	<a href="http://www.ti.com/medical">www.ti.com/medical</a>
Security	<a href="http://www.ti.com/security">www.ti.com/security</a>
Space, Avionics and Defense	<a href="http://www.ti.com/space-avionics-defense">www.ti.com/space-avionics-defense</a>
Transportation and Automotive	<a href="http://www.ti.com/automotive">www.ti.com/automotive</a>
Video and Imaging	<a href="http://www.ti.com/video">www.ti.com/video</a>
Wireless	<a href="http://www.ti.com/wireless-apps">www.ti.com/wireless-apps</a>

TI E2E Community Home Page

[e2e.ti.com](http://e2e.ti.com)

Mailing Address: Texas Instruments, Post Office Box 655303, Dallas, Texas 75265  
Copyright © 2011, Texas Instruments Incorporated