

LCBSB/CBSB Circuit Board Support on Base

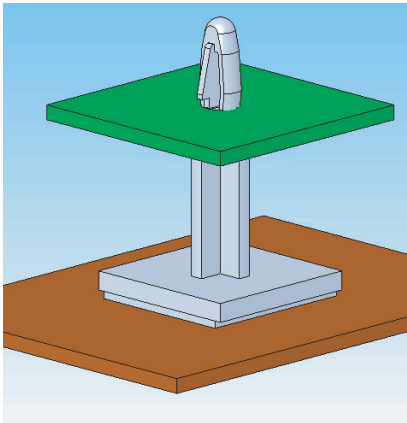

LCBSB

Top Hole: Snap-lock: 4 ± 0.08
Panel Thickness: 1.57

Fig. 1

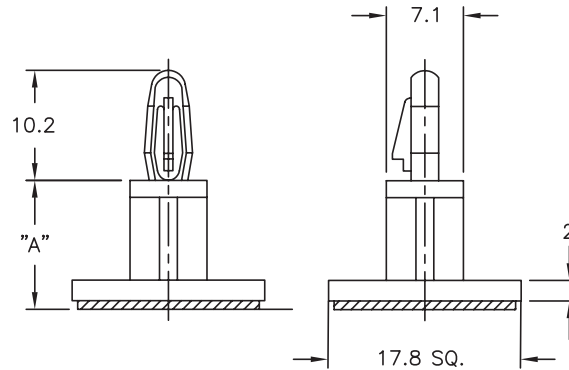

CBSB

Top Hole: Snap-fit: 4 ± 0.08
Panel Thickness: 1.57

Fig. 2

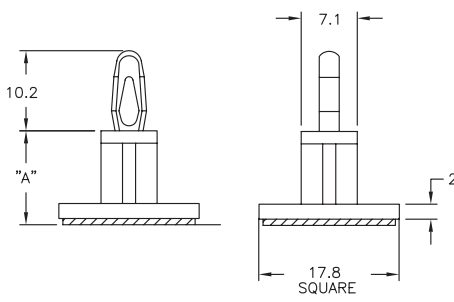

LCBSBM

Top Hole: Snap-lock: 3.18 ± 0.05
Panel Thickness: 1.57

Fig. 3

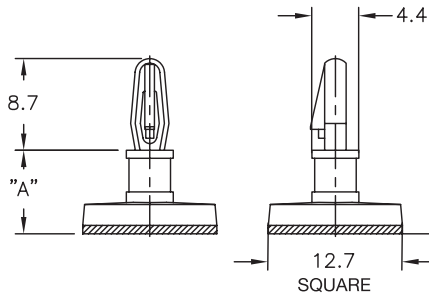

CBSBT

Top Hole: Snap-lock: 2.54 ± 0.05
Panel Thickness: 1.63 Max.

Fig. 4

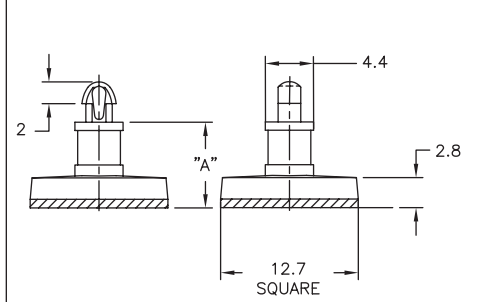

LCBSB (Fig. 1)	CBSB (Fig. 2)	LCBSBM (Fig. 3)	CBSBT (Fig. 4)	Standard Pack: 1000 per bag
Mat'l: Nylon 6/6, RMS-01* Color: Natural	Mat'l: Nylon 6/6, RMS-01* Color: Natural	Mat'l: Nylon 6/6, RMS-01* Color: Natural	Mat'l: Nylon 6/6, RMS-01* Color: Natural	"A" Standoff Height
LCBSB-3-01A2-RT	CBSB-3-01A2-RT	LCBSBM-3-01A2-RT	CBSBT-3-01A2-RT	4.8
LCBSB-4-01A2-RT	CBSB-4-01A2-RT	LCBSBM-4-01A2-RT	CBSBT-4-01A2-RT	6.4
-	-	LCBSBM-5-01A2-RT	CBSBT-5-01A2-RT	7.9
LCBSB-6-01A2-RT	CBSB-6-01A2-RT	LCBSBM-6-01A2-RT	CBSBT-6-01A2-RT	9.5
-	-	LCBSBM-7-01A2-RT	CBSBT-7-01A2-RT	11.1
LCBSB-8-01A2-RT	CBSB-8-01A2-RT	LCBSBM-8-01A2-RT	CBSBT-8-01A2-RT	12.7
LCBSB-9-01A2-RT	CBSB-9-01A2-RT	LCBSBM-9-01A2-RT	CBSBT-9-01A2-RT	14.3
LCBSB-10-01A2-RT	CBSB-10-01A2-RT	LCBSBM-10-01A2-RT	CBSBT-10-01A2-RT	15.9
LCBSB-12-01A2-RT	CBSB-12-01A2-RT	-	-	19.1
LCBSB-14-01A2-RT	CBSB-14-01A2-RT	-	-	22.2
LCBSB-16-01A2-RT	CBSB-16-01A2-RT	-	-	25.4
LCBSB-18-01A2-RT	CBSB-18-01A2-RT	-	-	28.6
*Available in UL94 V0 material. To order, replace -01 with -19.				
Adhesive Backing: RMS-24, double sided adhesive tape with release tab.				
Also available without adhesive by special order; 5,000 piece minimum.				

Metric Lengths	
LCBSB (Fig. 1)	Standard Pack: 1000 per bag
Mat'l: Nylon 6/6, RMS-01* Color: Natural	"A" Standoff Height
LCBSB-6M-01A2-RT	6
LCBSB-8M-01A2-RT	8
LCBSB-10M-01A2-RT	10
LCBSB-12M-01A2-RT	12
LCBSB-14M-01A2-RT	14
LCBSB-16M-01A2-RT	16
*Available in UL94 V0 material. To order, replace -01 with -19.	
Adhesive Backing: RMS-24, double sided adhesive tape with release tab.	
Also available without adhesive by special order; 5,000 piece minimum.	