

**Light Duty Mounts - Type SEM**

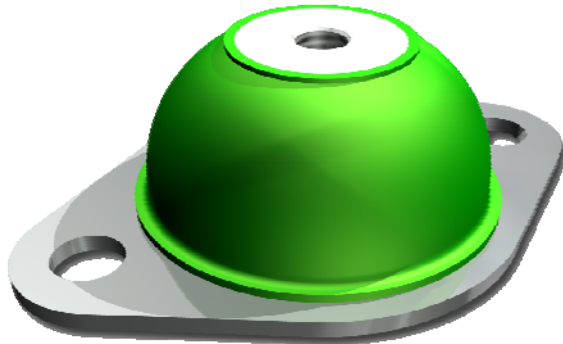

**Applications**

- Instruments
- Measuring Equipment
- Small Machinery
- Electric Engines
- Pumps
- Radiators

The SEM range of Mounts are low frequency elastomeric noise and vibration isolators for industrial equipment and machinery.

They are normally used to insulate the transmission of noise and vibration in vertically applied loads.

Their applications can include Generators, Blowers, Pumps, Road Machines or any equipment that by design is unbalanced. They can also be used for isolating instrumentation in mobile, military or road applications.

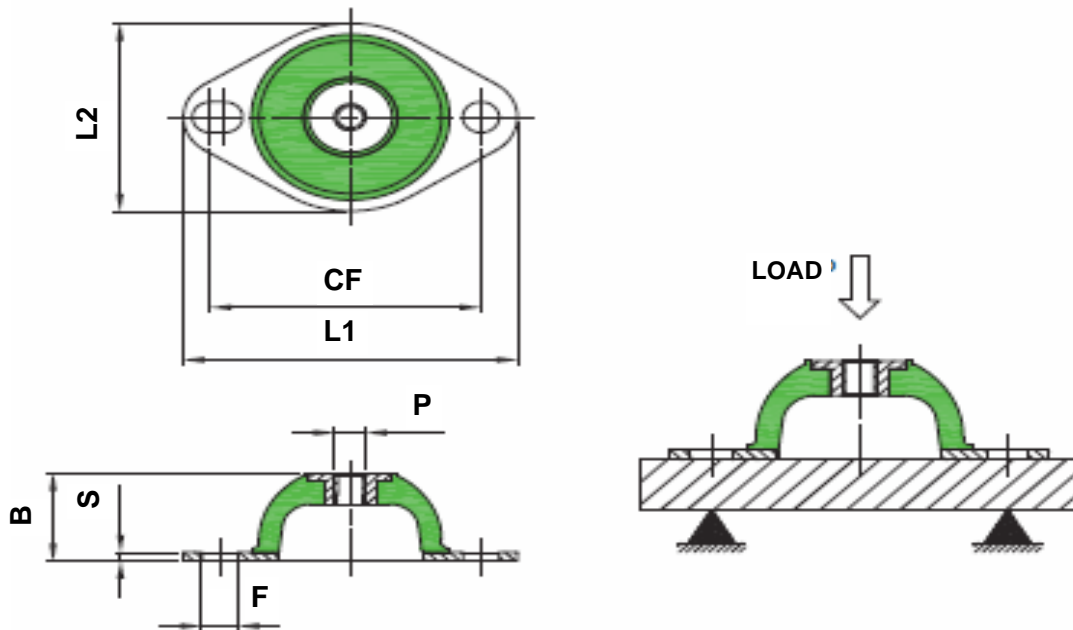

Farnell Ref:	Fibet Ref:	Hardness (IRHD)	B	L1	L2	P	CF	F (xM)	S	Average Stiffness (daN/mm)	Maximum Load (daN)	Maximum Deflection (mm)
4999575	SEM-8525-45	45	25	88	59	M8	65-73	8 x 12	2.5	4.0	26.5	7.5
4999599	SEM-8525-70	70	25	88	59	M8	65-73	8 x 12	2.5	10.0	75.0	7.5