



PART NO.

MCBF7330-221MU

REVISIONS

ECN #	REV	DESCRIPTION	DRAWN	DATE	CHECKD	DATE	APPRVD	DATE
-	A	RELEASED	Sidhu	14/2/11	Jagan	14/2/11	Farnell	28/2/11

Configurations and Dimensions

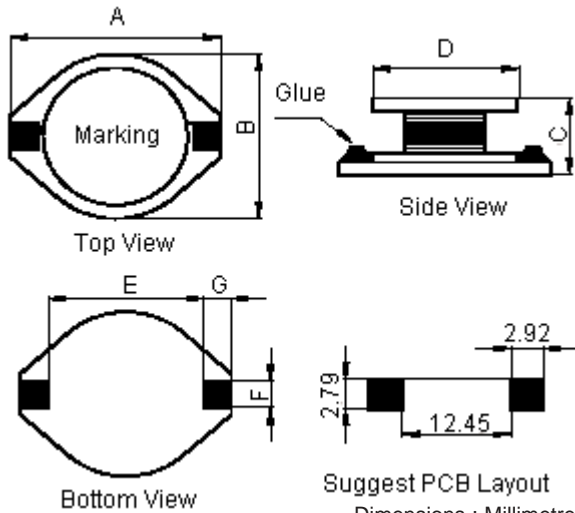

A	18.54 mm	Maximum
B	15.24 mm	Maximum
C	7.11 mm	Maximum
D	12.7 ±0.3 mm	-
E	12.92 mm	Reference
F	2.54 mm	Reference
G	2.54 mm	Reference

Schematic Diagram

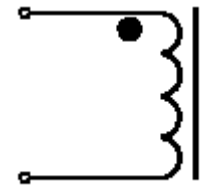

Note:

- (1) Wire Ø0.32mm x 1P 2UEWF 155°C
- (2) 57.5TS (Reference)

Marking : 221 YY : Year
YYWW WW :Week

Electrical Characteristics (at 25°C)

Test Condition		
100KHz 0.25V	L	220µH ±20%
at 25°C	DCR	380mΩ (Maximum)
100KHz 0.25V I _{rms} = 1.2A	ΔT	Temperature Rise 40°C (Maximum)

Operating temperature: -40°C to +125°C

Test Data for Mechanical

Test Item	A mm	B mm	C mm	D mm	E mm	F mm	G mm
Specification	18.54 (Maximum)	15.24 (Maximum)	7.11 (Maximum)	12.7 ±0.3	12.92 (Reference)	2.54 (Reference)	2.54 (Reference)
1	18.11	13.91	6.59	12.72	12.91	2.52	2.56
2	18.06	13.93	6.54	12.71	13.02	2.48	2.52
3	18.13	13.96	6.51	12.75	12.93	2.58	2.45
4	18.09	13.99	6.56	12.78	12.94	2.69	2.51
5	18.12	14.01	6.55	12.81	12.98	2.43	2.63
Average	18.1	13.96	6.55	12.75	12.96	2.54	2.53

This data sheet and its contents (the "Information") belong to the Premier Farnell Group (the "Group") or are licensed to it. No licence is granted for the use of it other than for information purposes in connection with the products to which it relates. No licence of any intellectual property rights is granted. The Information is subject to change without notice and replaces all data sheets previously supplied. The Information supplied is believed to be accurate but the Group assumes no responsibility for its accuracy or completeness, any error in or omission from it or for any use made of it. Users of this data sheet should check for themselves the Information and the suitability of the products for their purpose and not make any assumptions based on information included or omitted. Liability for loss or damage resulting from any reliance on the Information or use of it (including liability resulting from negligence or where the Group was aware of the possibility of such loss or damage arising) is excluded. This will not operate to limit or restrict the Group's liability for death or personal injury resulting from its negligence. SPC MULTICOMP is the registered trademark of the Group. © Premier Farnell plc 2011.

TOLERANCES:

UNLESS OTHERWISE SPECIFIED, DIMENSIONS ARE FOR REFERENCE PURPOSES ONLY.

DRAWN BY:	DATE:
Sidhu	14/02/11
CHECKED BY:	DATE:
Jagan	14/02/11
APPROVED BY:	DATE:
Farnell	28/02/11

DRAWING TITLE:

Inductor

SIZE A	DWG NO. M10003217	ELECTRONIC FILE BF7330-221MU	REV A
SCALE: NTS	U.O.M.: mm	SHEET: 1 OF 3	



PART NO.

MCBF7330-221MU

REVISIONS

ECN #	REV	DESCRIPTION	DRAWN	DATE	CHECKD	DATE	APPRVD	DATE
-	A	RELEASED	Sidhu	14/2/11	Jagan	14/2/11	Farnell	28/2/11

Electric Characteristics

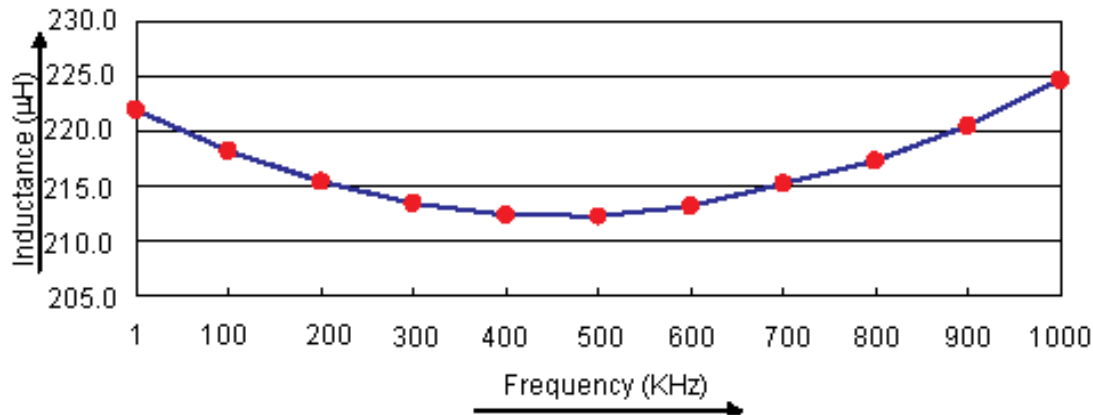
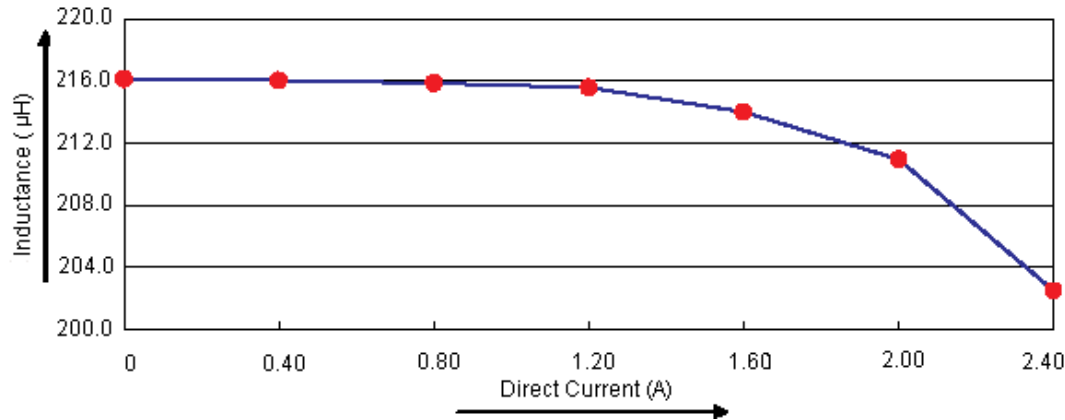

Test Data for Electrical

Test Item	L µH	DCR mΩ	ΔT
Condition	100KHz 0.25V	at 25°C	100KHz 0.25V I _{rms} = 1.2A
Specification	220 ±20%	380 (Maximum)	Temperature Rise 40°C (Maximum)
1	210.56	337.15	OK
2	219.62	342.3	OK
3	217.12	338.55	OK
4	220.05	343.4	OK
5	219.52	340.1	OK
Average	217.37	340.3	OK

This data sheet and its contents (the "Information") belong to the Premier Farnell Group (the "Group") or are licensed to it. No licence is granted for the use of it other than for information purposes in connection with the products to which it relates. No licence of any intellectual property rights is granted. The Information is subject to change without notice and replaces all data sheets previously supplied. The Information supplied is believed to be accurate but the Group assumes no responsibility for its accuracy or completeness, any error in or omission from it or for any use made of it. Users of this data sheet should check for themselves the information and the suitability of the products for their purpose and not make any assumptions based on information included or omitted. Liability for loss or damage resulting from any reliance on the Information or use of it (including liability resulting from negligence or where the Group was aware of the possibility of such loss or damage arising) is excluded. This will not operate to limit or restrict the Group's liability for death or personal injury resulting from its negligence. SPC MULTICOMP is the registered trademark of the Group. © Premier Farnell plc 2011.

TOLERANCES:

UNLESS OTHERWISE SPECIFIED, DIMENSIONS ARE FOR REFERENCE PURPOSES ONLY.

DRAWN BY:	DATE:
Sidhu	14/02/11
CHECKED BY:	DATE:
Jagan	14/02/11
APPROVED BY:	DATE:
Farnell	28/02/11

DRAWING TITLE:

Inductor

SIZE A	DWG NO. M10003217	ELECTRONIC FILE BF7330-221MU	REV A
SCALE: NTS	U.O.M.: mm	SHEET: 2 OF 3	



PART NO.

MCBF7330-221MU

REVISIONS

ECN #	REV	DESCRIPTION	DRAWN	DATE	CHECKD	DATE	APPRVD	DATE
-	A	RELEASED	Sidhu	14/2/11	Jagan	14/2/11	Farnell	28/2/11

Reliability Test

Test Items	Specifications	Test Method and Remarks
Operating temperature range	-40°C to +125°C	Including temperature rise due to self-generated heat
Storage condition	Ambient temperature : 0°C to 40°C Humidity : Below 70%RH	To maintain the solderability of terminal electrodes, care must be taken to control temperature and humidity in the storage area.
Moisture sensitivity	Appearance : No abnormality No damage DCR change : Within ±20% Inductance change : Within ±20%	According to J-STD-020B level 3 Test condition : 60°C 60% RH Test duration : 40 hours Recovery : 1 to 2 hours of recovery under the standard condition after the removal from the test chamber.
Solderability	All termination shall exhibit a continuous solder coating free from defects for a minimum of 90% of the surface area of any individual lead.	According to J-STD-002B Steam aging category : 97°C 98% RH Steam aging duration : 8 hours Solder : Lead-free solder Solder temperature : 260 ±5°C Dip time : 5 +0/-0.5 seconds.

Material List

No.	Item	Material Description
1	Core	T2 DR12.7 x 5.6C B5.8 F3.3
2	Wire	Ø0.32mm x 1P 2UEWF 155°C
3	Solder (Lead Free)	Sn99.3% / Cu0.7%
4	Glue	TH320
5	Base	DAP HD 127-3

Part Number Table

Description	Part Number
Inductor, 220µH, 20%, SMD	MCBF7330-221MU

<http://www.farnell.com>

<http://www.newark.com>

<http://www.cpc.co.uk>

This data sheet and its contents (the "Information") belong to the Premier Farnell Group (the "Group") or are licensed to it. No licence is granted for the use of it other than for information purposes in connection with the products to which it relates. No licence of any intellectual property rights is granted. The Information is subject to change without notice and replaces all data sheets previously supplied. The Information supplied is believed to be accurate but the Group assumes no responsibility for its accuracy or completeness, any error in or omission from it or for any use made of it. Users of this data sheet should check for themselves the Information and the suitability of the products for their purpose and not make any assumptions based on information included or omitted. Liability for loss or damage resulting from any reliance on the Information or use of it (including liability resulting from negligence or where the Group was aware of the possibility of such loss or damage arising) is excluded. This will not operate to limit or restrict the Group's liability for death or personal injury resulting from its negligence. SPC MULTICOMP is the registered trademark of the Group. © Premier Farnell plc 2011.

TOLERANCES:

UNLESS OTHERWISE SPECIFIED, DIMENSIONS ARE FOR REFERENCE PURPOSES ONLY.

DRAWN BY:

Sidhu

DATE:

14/02/11

CHECKED BY:

Jagan

DATE:

14/02/11

APPROVED BY:

Farnell

DATE:

28/02/11

DRAWING TITLE:

Inductor

SIZE
A

DWG NO.

M10003217

ELECTRONIC FILE

BF7330-221MU

REV

A

SCALE: NTS

U.O.M.: mm

SHEET: 3 OF 3