

Application Note

Implementing Advanced Circuit Protection Technologies for RS-485 Ports



TBU-CA065-300-WH



MOV-10D201K



CDSOT23-SM712

In the development of today's process control architectures and closed-loop systems there are numerous serial drops using point to point, multi-drop or multipoint systems. The distances between serial drops can range from several hundred meters to over a thousand meters. Using data transfer protocols such as LVDS, TIA/EIA-232, TIA/EIA-422, TIA/EIA-485, field buses, CAN, Profibus, and Interbus enables the communication among the various remote devices such as sensors, actuators or monitors connected throughout the system. RS-485 is one of the most common interface standards, and due to their prevalence in industrial settings RS-485 systems must be capable of operating in very noisy and harsh electrical environments. In order to avoid damage and overload of the system, the use of robust and reliable circuit protection is required. This application note describes the need for circuit protection on RS-485 serial device ports, and introduces a solution using Bourns® TBU® High-Speed Protector (HSP), Metal Oxide Varistor (MOV) and Transient Voltage Suppressor (TVS) products to meet the required industry standards on RS-485 port interfaces.

Introduction to RS-485

RS-485 is a standard communication network for industrial communications, and features fast data rates achieving 35 Mbps for short distances and 100 kbps over longer distances. When covering longer distances, it is not unusual to encounter miswiring and short circuit faults. Transients and surges also can be generated by induced energy on the data lines due to environmental conditions or switching of heavy inductive loads. Any of these issues can seriously affect the data transfer performance on the serial port. One common application of RS-485 that illustrates its sensitivity is an elevator control system. With cables in motion and large motors and inductors in proximity, rugged communication systems are required. RS-485 is also commonly deployed in building automation, security system controls, and other industrial communication applications.

RS-485 systems are inherently more robust than many other networks because the signal is delivered differentially between two wires relative to a third reference voltage. The reference voltage is often, but not always, the local earth potential. This provides substantial immunity to common mode noise such as ground noise and induced noise from nearby motors, solenoids and transformers. The interface uses voltages that are high by communication system standards, also making it more robust than networks using other protocols. For instance, Ethernet signals are about 2 V, though much internal communication in a computer is even lower, and the popular USB standard communicates at a maximum of 5 V. RS-485, on the other hand, allows for common mode voltages from -7 volts to +12 volts. Voltage drop between distant nodes can be accommodated without adding expensive equipment along the path.



TBU-CA065-300-WH



MOV-10D201K



CDSOT23-SM712

RS-485 Port Interface Requirements

Displayed in Table 1 are the interface specifications for RS-485 ports. Key electrical parameters of -7 V to +12 V operating voltage with 32 Mbps data transfer at distances of 1200 m are included. A fully compliant RS-485 port must meet IEC 61000-4-2 (ESD), IEC 61000-4-4 (EFT) and IEC 61000-4-5 (Surge) standards.

Table 1: RS-485 Interface Specifications

| | |
|--------------------------------------|---------------|
| Differential | yes |
| Max. number of drivers | 32 |
| Max. number of receivers | 32 |
| Modes of operation | half duplex |
| Network topology | multipoint |
| Max. distance | 1200 m |
| Max. speed at 12 m | 32 Mbps |
| Max. speed at 1200 m | 100 kbps |
| Receiver input sensitivity | +/- 200 mV |
| Receiver input range | -7 V to +12 V |
| Max. driver output voltage | -7 V to +12 V |
| Max. driver output voltage with load | +/- 1.5 V |

Every serial port design depends on the recommended voltage range for the bus pins. RS-485 defines how much protection the device has beyond the -7 V to +12 V. If the environment demands that the bus survives up to ± 24 V then external protection must be added or adapted to meet compliance standards. Bourns offers different circuit protection technologies for overcurrent and overvoltage protection. The selection of a device or combination of devices depends on the requirements of the application and specifications of other devices such as the serial bus driver.

Protection for RS-485 Ports



TBU-CA065-300-WH



MOV-10D201K



CDSOT23-SM712

Single-stage protection usually consists of a single TVS device on each data line. A general protection scheme for each node of an RS-485 network includes a TVS diode array such as the CDSOT23-SM712 from Bourns. This provides the overvoltage protection for the RS-485 transceiver across the entire -7 V to +12 V common mode voltage range. For RS-485 systems with limited exposure, this diode array may be all that is needed for reliable operation. However, many RS-485 networks are deployed in environments where failure is not acceptable, repairs are difficult or expensive, or the surge threats overpower this simple protection scheme.

For more exposed lines that may see large and fast surges, three-stage protection shown in figure 1 is more suitable in its ability to withstand these conditions. It consists of TVS diodes, TBU[®] HSP devices, and one or more MOVs. The characteristics of these three technologies are complementary, working together to provide protection to the RS-485 interface where they would lack if used independently. The MOV can handle high currents with a high threshold voltage to handle a variety of transients. The TBU[®] HSP has a small series impedance that limits current and voltage to which the equipment is exposed. The MOV protects the TBU[®] HSP from excessive voltage after the TBU[®] HSP triggers. The MOV is fast enough to protect against ESD, and in combination with the TVS diode, provides voltage suppression against ESD/EFT transients.

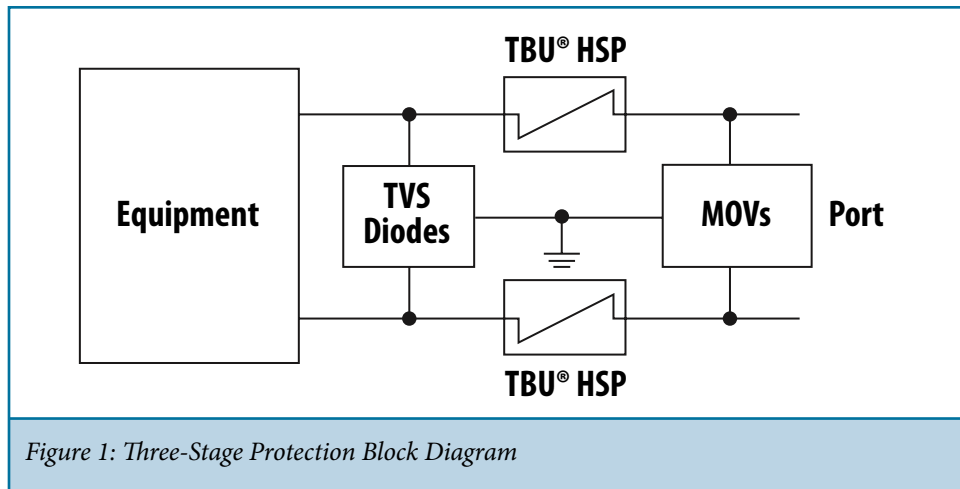

Understanding Bourns[®] TBU[®] High-Speed Protector Operation

The TBU-CA Series of Bourns[®] TBU[®] HSP products are low capacitance, single, bidirectional, high-speed circuit protection components constructed with MOSFET semiconductor technology. They are designed to protect against faults caused by short circuits, AC power cross, induction and lightning surges up to rated limits, and reset once the fault clears. The TBU[®] HSP offers a significant performance increase in terms of response time. It is easy to place and route a TBU[®] HSP in a design since the TBU-CA package measures a mere 6.5 mm by 4 mm. The TBU[®] HSP is provided in a surface mount DFN package and meets industry standard requirements such as RoHS* and Pb Free solder reflow profiles.

Effective Circuit Protection in Action

The example in Figure 2 illustrates a full RS-485 protection solution using TVS diodes, TBU[®] HSP devices, and MOVs. TVS diodes provide overvoltage protection against voltage surges. To protect the TVS diode array against AC power cross events or large transients as well as overcurrent protection for the RS-485 driver, a TBU[®] high-speed protector is placed in each line. Each TBU[®] HSP provides sub-microsecond protection by transitioning to a protected state with very high impedance within 1 μ s if the line current should exceed 100 mA. Finally, to protect the TBU[®] HSP devices from high voltage transients, a MOV-10D201K is placed on the line side of the node interface. These MOVs are designed to coordinate with the TBU[®] HSP to provide extremely fast voltage protection. If sustained power cross events are anticipated, an additional fuse may be placed in each line to open in case of sustained MOV operation.



TBU-CA065-300-WH



MOV-10D201K



CDSOT23-SM712

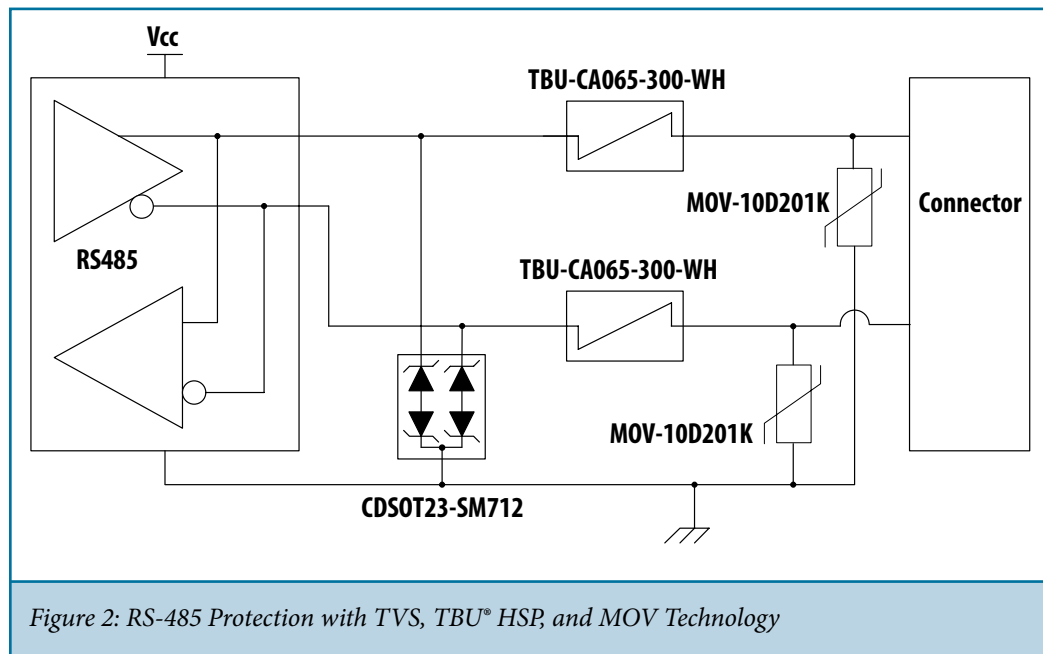

Figure 2: RS-485 Protection with TVS, TBU[®] HSP, and MOV Technology

The protection solution shown is very robust with the addition of the TBU[®] HSP to the circuit. Designers of industrial RS-485 systems will find that the reliability of their hardware is taken to new levels if this TBU[®] HSP-based three stage solution is adopted. Three technologies work together to provide this comprehensive, fast solution that was not achievable prior to the release of the TBU[®] high-speed protector. Due to the layered protection scheme, the TVS array is fully protected by the TBU[®] HSP and the TBU[®] HSP is fully protected by the MOV. The limits of surge protection are then those of the MOV itself. Alternative combinations can be created based on the system specifications. Contact a Bourns Applications Engineer for further support with circuit protection designs for RS-485 interfaces.



TBU-CA065-300-WH



MOV-10D201K



CDSOT23-SM712

Transient and Protection Level Test Data

The following information is actual test data provided to demonstrate the ESD, EFT, surge, and AC power cross transient protection of the schematic in figure 2, meeting the IEC requirements of table 2. The oscillographs provided below show the actual let-through voltage measured at the protected load.

Table 2: ESD, EFT, Power Cross, Surge Transient Protection Levels

| Transient | Level of transient protection | Figure |
|----------------------|--|---------|
| ESD (IEC61000-4-2) | Level 4 - 8 KV (contact)/15 KV (air) | 3 - 6 |
| Surge (IEC61000-4-5) | Class 3 - 25 A | 7 & 8 |
| EFT (IEC61000-4-4) | Level 3 - 1 KV | 9 & 10 |
| Power Cross | 28 V _{rms} & 120 V _{rms} | 11 & 12 |

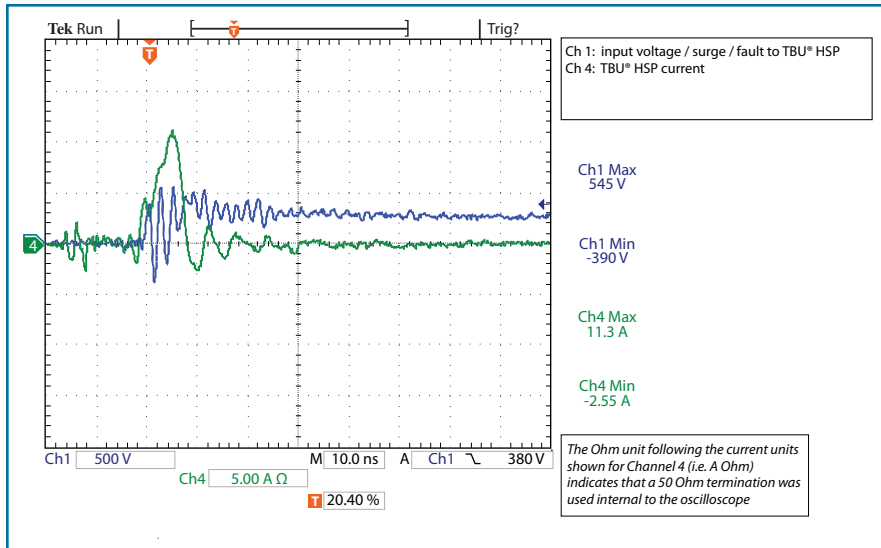

Figure 3: 8 KV Contact Discharge (Level 4) Positive Stroke

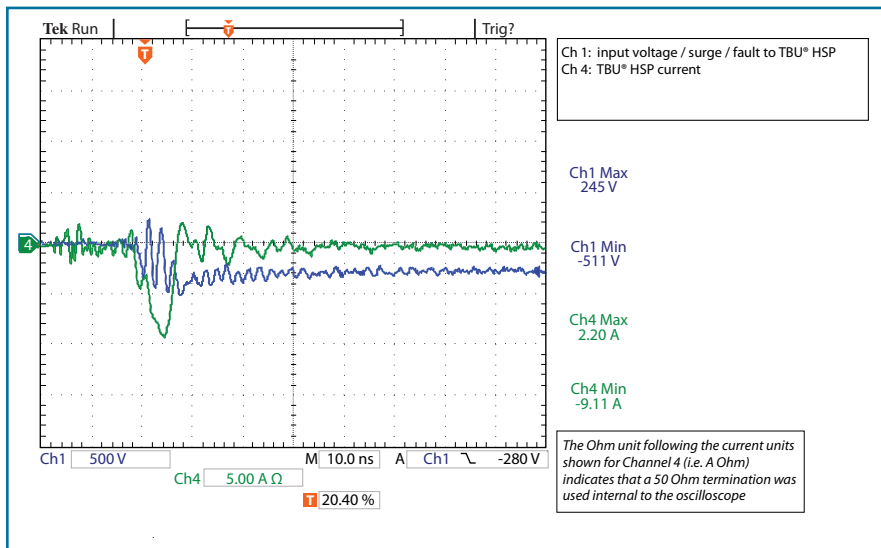

Figure 4: 8 KV Contact Discharge (Level 4) Negative Stroke



TBU-CA065-300-WH



MOV-10D201K



CDSOT23-SM712

Transient and Protection Level Test Data (Continued)

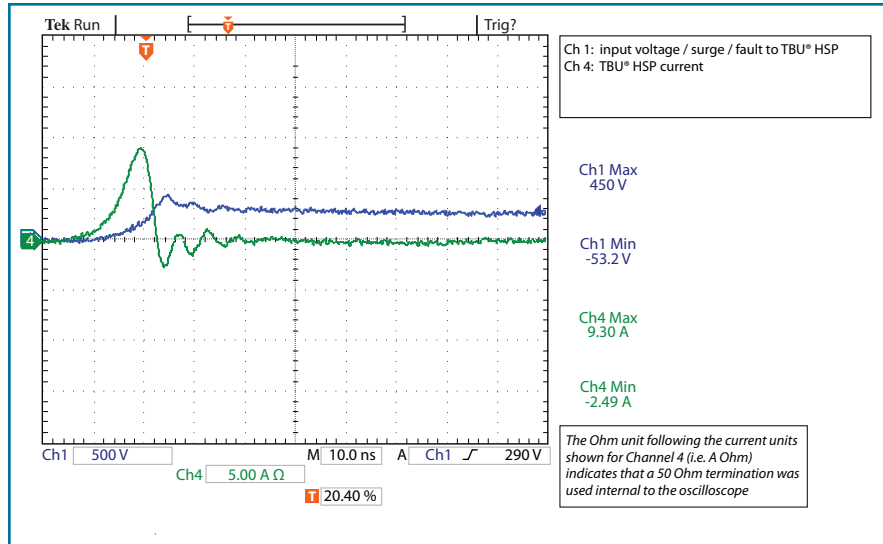

Figure 5: 15 KV Air Discharge (Level 4) Positive Stroke

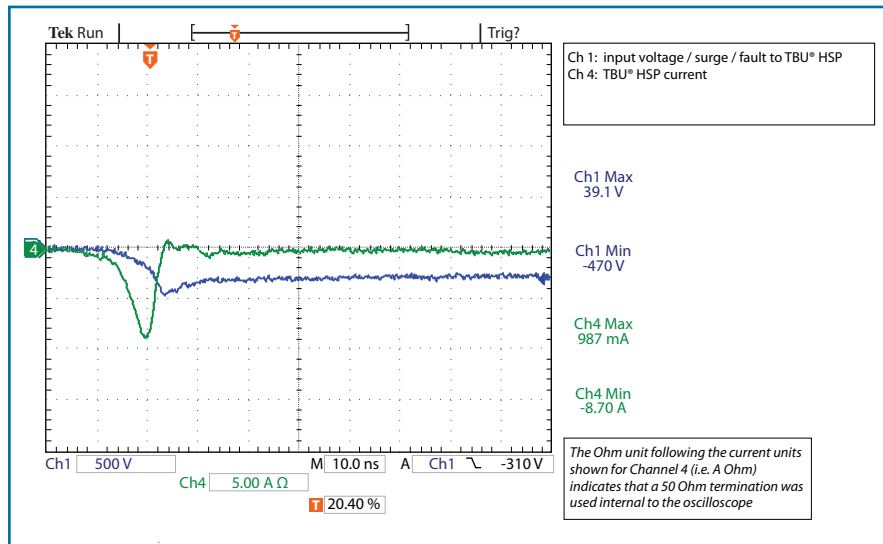

Figure 6: 15 KV Air Discharge (Level 4) Negative Stroke



TBU-CA065-300-WH



MOV-10D201K



CDSOT23-SM712

Transient and Protection Level Test Data (Continued)

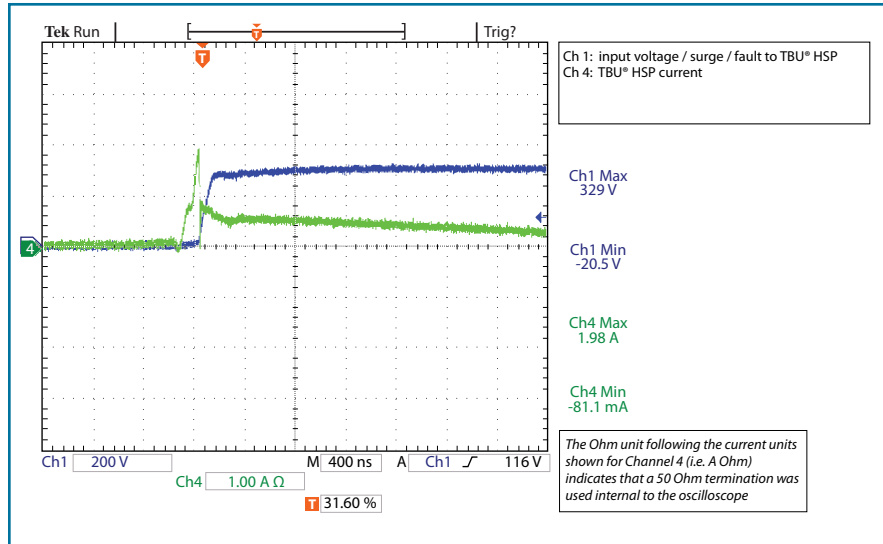

Figure 7: 1.2/50 1 KV Positive Surge

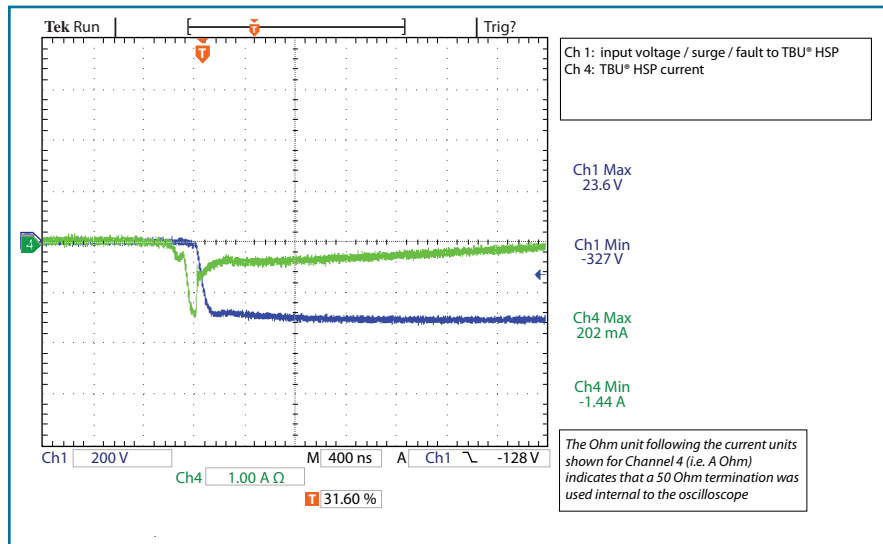

Figure 8: 1.2/50 1 KV Negative Surge



TBU-CA065-300-WH



MOV-10D201K



CDSOT23-SM712

Transient and Protection Level Test Data (Continued)

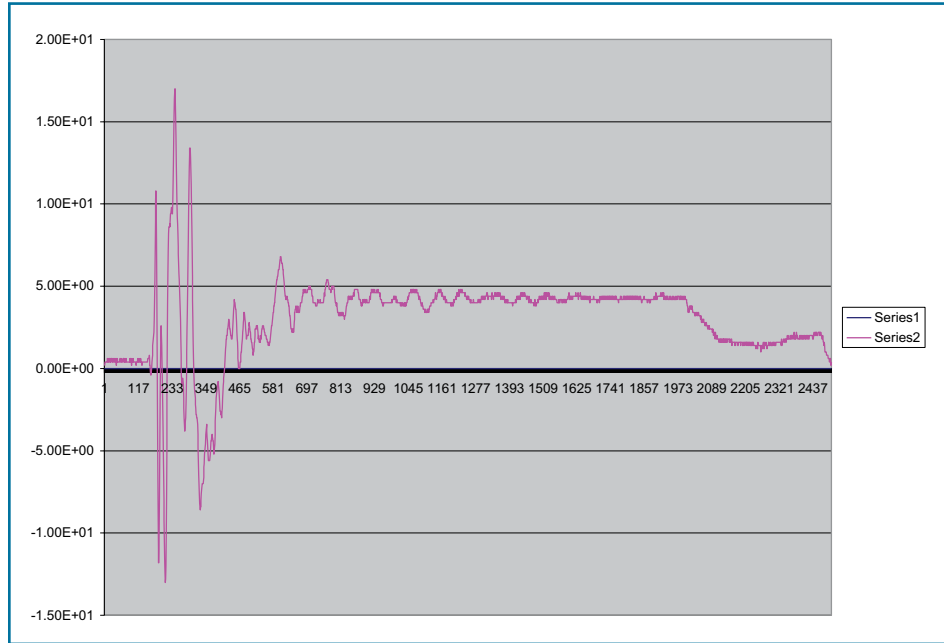

Figure 9: Capacitively Coupled EFT 1 kV Positive Transient

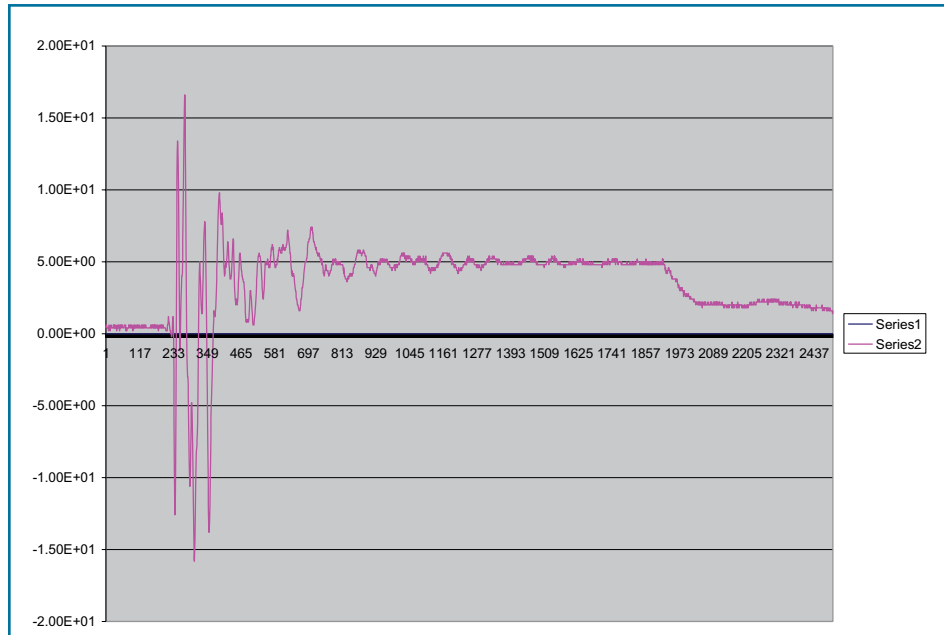

Figure 10: Capacitively Coupled EFT 1 kV Negative Transient



TBU-CA065-300-WH



MOV-10D201K



CDSOT23-SM712

Transient and Protection Level Test Data (Continued)

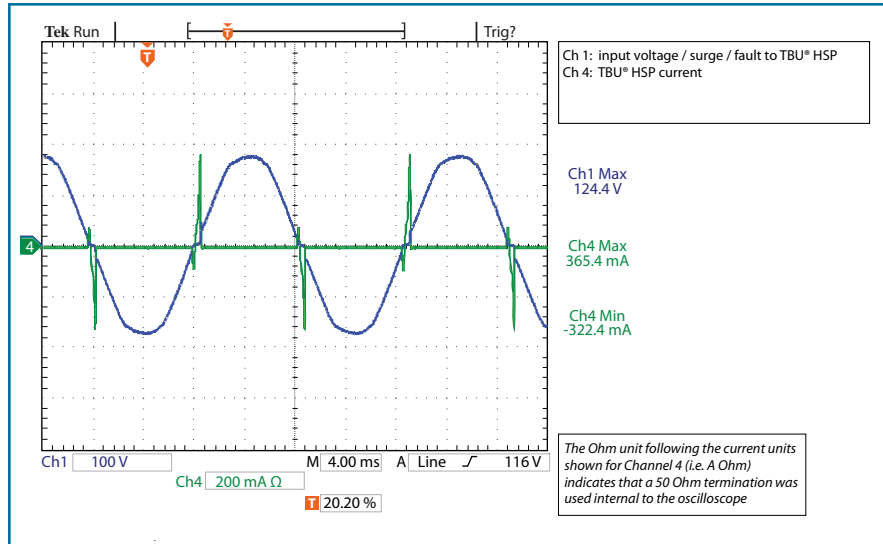

Figure 11: 120 V_{RMS} Power Cross

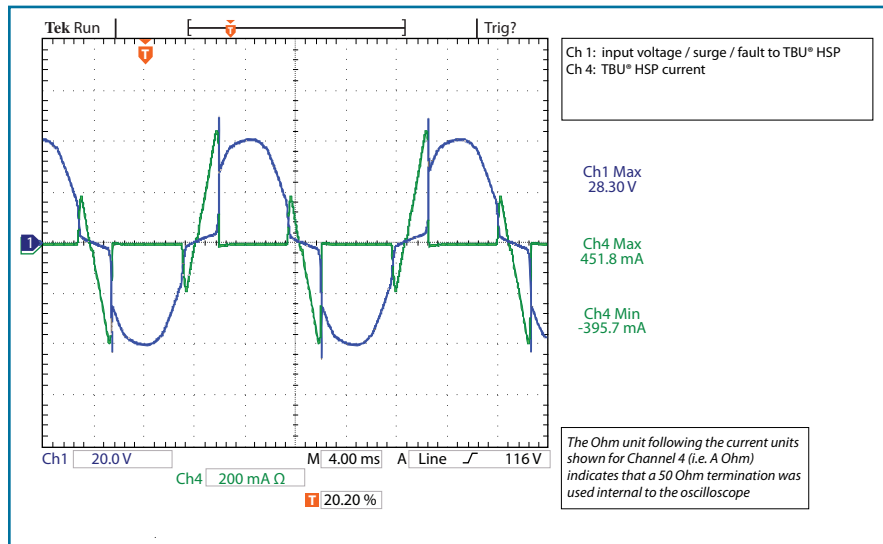

Figure 12: 28 V_{RMS} Power Cross

Implementing Advanced Circuit Protection Technologies for RS-485 Ports

Summary

The recommended three-stage protection solution featuring Bourns® TBU® HSP devices offer enhanced performance over competing technologies. Design engineers can take advantage of this technology to increase the surge and transient protection levels on RS-485 ports. This RS-485 solution provides protection against AC power cross, ESD, EFT and surge pulses with test results detailed in table 1 and in figures 1 and 2. The TBU® HSP provides power cross and overcurrent protection on the RS-485 lines while the TVS diode provides voltage clamping to protect against ESD/EFT transients. TVS diodes create an avalanche current to trigger the TBU® HSP devices. The Bourns® MOV is selected to protect the TBU® HSP by limiting the maximum voltage to which the TBU® device is exposed. Different options for part number selection are available for this TBU® HSP-based three-stage solution. The compact size of the TBU® HSP can reduce the overall board area compared to what was required previously to meet the protection requirements. The use of Bourns® TBU® HSP devices brings a new level of overvoltage and overcurrent protection to RS-485 drivers.



TBU-CA065-300-WH



MOV-10D201K



CDSOT23-SM712

Why Bourns?

TBU® high-speed protector technology is unique to Bourns, a company that has been a proven leader in the circuit protection industry for several decades. Bourns invests in innovative new products through internal development and strategic acquisition of companies or products lines. Bourns serves diverse markets from computers and peripherals to telecommunications. The company's commitment to excellence in design and customer service and its established track record in circuit protection for over half a century set Bourns apart from its competition in terms of quality and integrity.

References:

More information on the TBU® HSP and other Bourns circuit protection solutions can be found online:

- http://www.bourns.com/data/global/pdfs/bourns_tbu_white_paper.pdf
- http://www.bourns.com/data/global/pdfs/TBU-CA_MDS.pdf
- <http://www.bourns.com/ProductFamily.aspx?name=circuitprotection>

For further technical support and for complete port solutions, please visit

www.bourns.com

"Bourns" and "TBU" are registered trademarks of Bourns, Inc. in the U.S. and other countries.
COPYRIGHT © 2011 • BOURNS, INC. • 05/11 • e/CPK1114

*RoHS Directive 2002/95/EC Jan. 27, 2003 including Annex.