

TLV431

1.24V Cost effective shunt regulator

Description

The TLV431 is a three terminal adjustable shunt regulator offering excellent temperature stability and output current handling capability up to 20mA. The output voltage may be set to any chosen voltage between 1.24 and 18 volts by selection of two external divider resistors.

The TLV431 can be used as a replacement for zener diodes in many applications requiring an improvement in zener performance.

The TLV431 is available in 2 grades with initial tolerances of 1% and 0.5% for the A and B grades respectively.

Features

- Low Voltage Operation $V_{REF} = 1.24V$
- Temperature range -40 to 125°C
- Reference Voltage Tolerance at 25°C
 - 0.5%.....TLV431B
 - 1%.....TLV431A
- Typical temperature drift
 - 4 mV (0°C to 70°C)
 - 6 mV (-40°C to 85°C)
 - 11mV (-40°C to 125°C)
- 80µA Minimum cathode current
- 0.25Ω Typical Output Impedance
- Adjustable Output Voltage V_{REF} to 18V

Applications

- Opto-coupler linearisation
- Linear regulators
- Improved Zener
- Variable reference

Order Information

TOL	Order code	Pack	Part mark	Status	Reel Size (inches)	Tape width (mm)	Quantity per reel
1%	TLV431AE5TA	SOT23-5	V1A	Active	7	8	3000
	TLV431AFTA	SOT23	V1A	Active	7	8	3000
	TLV431AH6TA	SC70-6	V1A	Active	7	8	3000
0.5%	TLV431BE5TA	SOT23-5	V1B	Active	7	8	3000
	TLV431BFTA	SOT23	V1B	Active	7	8	3000
	TLV431BH6TA	SC70-6	V1B	Active	7	8	3000

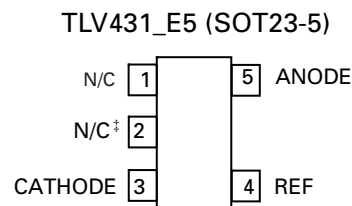
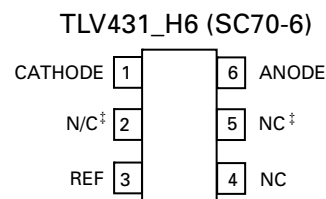
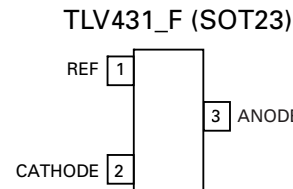

‡ Connected internally to substrate; should be left floating or connected to anode

Absolute Maximum Ratings

Cathode Voltage (V_{KA})	20V
Continuous Cathode Current (I_{KA})	-20 to 20mA
Reference input current range (I_{REF}).....	-0.050 mA to 3mA
Operating Junction Temperature.....	-40 to 150°C
Storage Temperature	-55 to 150°C

Operation above the absolute maximum rating may cause device failure. Operation at the absolute maximum ratings, for extended periods, may reduce device reliability.

Unless otherwise stated voltages specified are relative to the ANODE pin.

Package Thermal Data

Package	θ_{JA}	P_{DIS} $T_A = 25^\circ C, T_J = 150^\circ C$
SOT23	380°C/W	330 mW
SOT23-5	250°C/W	500 mW
SC70-6	380°C/W	330mW

Recommended Operating Conditions

		Min	Max	Units
V_{KA}	Cathode Voltage	V_{REF}	18	V
I_{KA}	Cathode Current	0.1	15	mA
T_A	Operating Ambient temperature range	-40	125	°C

Electrical Characteristics

Electrical characteristics over recommended operating conditions, $I_{KA} = 10\text{mA}$, $T_A = 25^\circ\text{C}$, unless otherwise stated.

Symbol	Parameter	Conditions	Min	Typ	Max	Units	
V_{REF}	Reference voltage	$V_{KA} = V_{REF}$ $T_A = 25^\circ\text{C}$	TLV431A	1.228	1.24	1.252	V
			TLV431B	1.234	1.24	1.246	
		$V_{KA} = V_{REF}$ $T_A = 0 \text{ to } 70^\circ\text{C}$	TLV431A	1.221		1.259	
			TLV431B	1.227		1.253	
		$V_{KA} = V_{REF}$ $T_A = -40 \text{ to } 85^\circ\text{C}$	TLV431A	1.215		1.265	
			TLV431B	1.224		1.259	
$V_{KA} = V_{REF}$ $T_A = -40 \text{ to } 125^\circ\text{C}$	TLV431A	1.209		1.271			
	TLV431B	1.221		1.265			
$V_{REF(\text{dev})}$	Deviation of reference voltage over full temperature range	$V_{KA} = V_{REF}$	$T_A = 0 \text{ to } 70^\circ\text{C}$		4	12	mV
			$T_A = -40 \text{ to } 85^\circ\text{C}$		6	20	
			$T_A = -40 \text{ to } 125^\circ\text{C}$		11	31	
$\frac{\Delta V_{REF}}{\Delta V_{KA}}$	Ratio of change in reference voltage to the change in cathode voltage	V_{KA} from V_{REF} to	6V		-1.5	-2.7	mV/V
			18V		-1.5	-2.7	
I_{REF}	Reference Input Current	$R_1 = 10\text{k}\Omega$ $R_2 = \text{OC}$		0.15	0.5	μA	
$I_{REF(\text{dev})}$	I_{REF} deviation over full temperature range	$R_1 = 10\text{k}\Omega$, $R_2 = \text{OC}$	$T_A = 0 \text{ to } 70^\circ\text{C}$		0.05	0.3	μA
			$T_A = -40 \text{ to } 85^\circ\text{C}$		0.1	0.4	
			$T_A = -40 \text{ to } 125^\circ\text{C}$		0.15	0.5	
$I_{K\text{MIN}}$	Minimum Cathode current for regulation	$V_{KA} = V_{REF}$	$T_A = 0 \text{ to } 70^\circ\text{C}$		55	80	μA
			$T_A = -40 \text{ to } 85^\circ\text{C}$		55	80	
			$T_A = -40 \text{ to } 125^\circ\text{C}$		55	100	
$I_{K(\text{OFF})}$	Off state current	$V_{KA} = 18\text{V}$ $V_{REF} = 0\text{V}$		0.001	0.1	μA	
Z_{KA}	Dynamic Output Impedance	$V_{KA} = V_{REF}$ $f = < 1\text{kHz}$ $I_K = 0.1 \text{ to } 15\text{mA}$		0.25	0.4	Ω	

Typical Characteristics

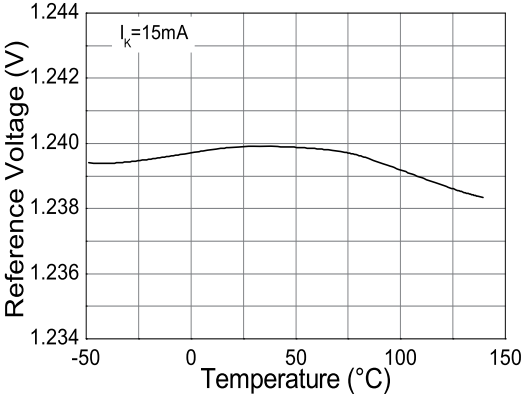

Reference Voltage vs Temperature

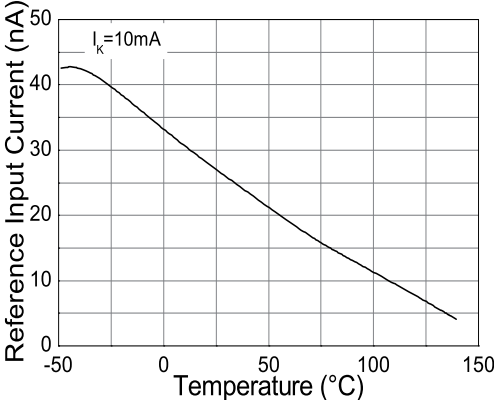

Reference Input Current vs Temperature

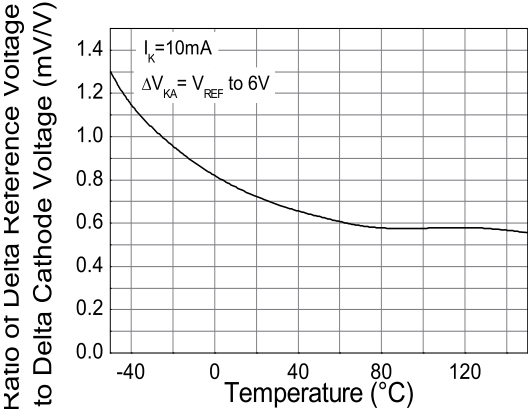

Ratio of Delta Reference Voltage to Delta Cathode Voltage vs Temperature

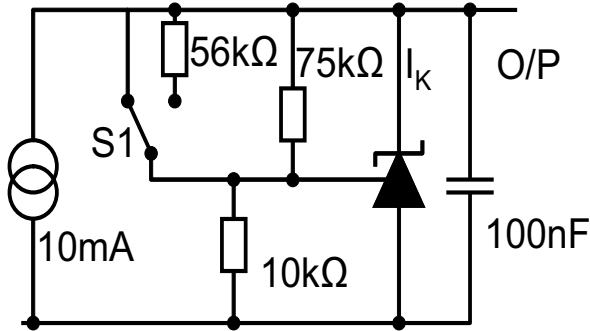

Typical Characteristics

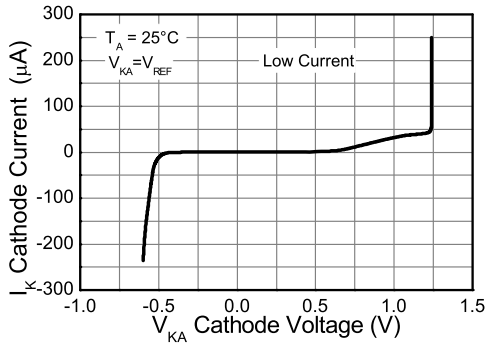

Cathode Current vs Voltage

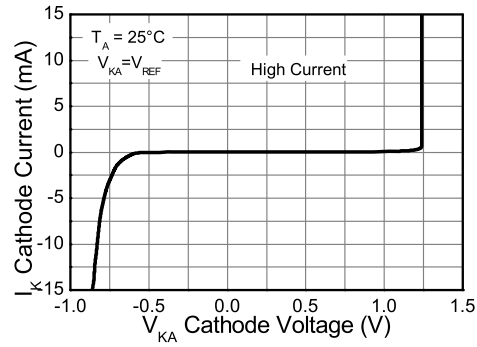

Cathode Current vs Voltage

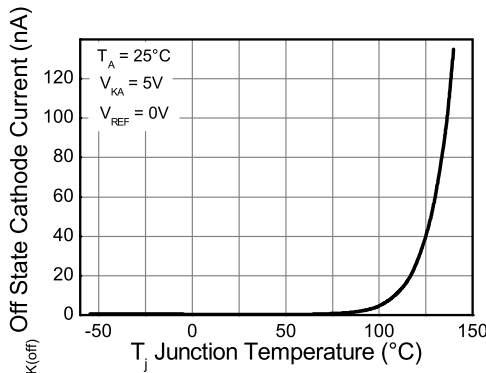

Off-State Current vs Junction Temperature

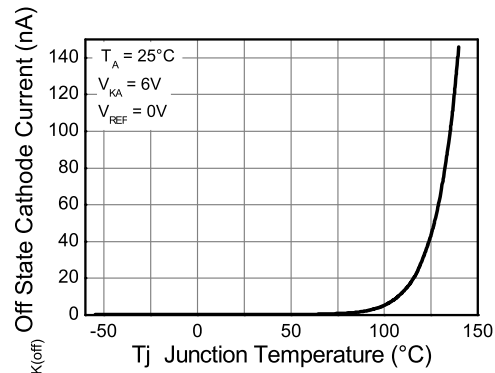

Off-State Current vs Junction Temperature

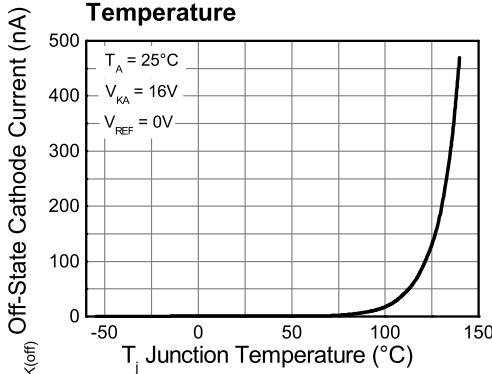

Off-State Current vs Junction Temperature

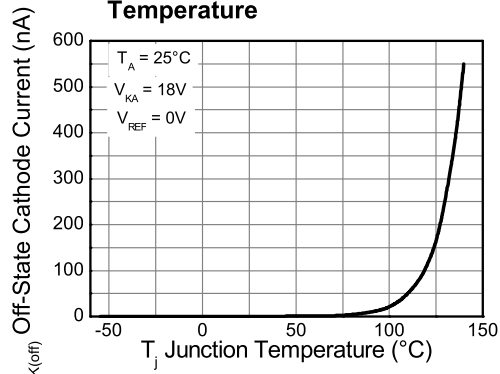

Off-state Current vs Junction Temperature

Typical Characteristics

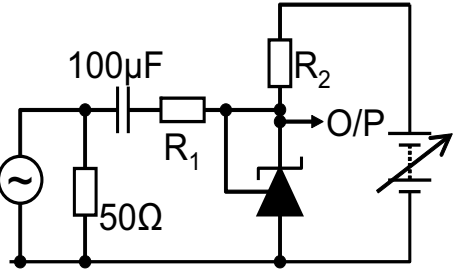
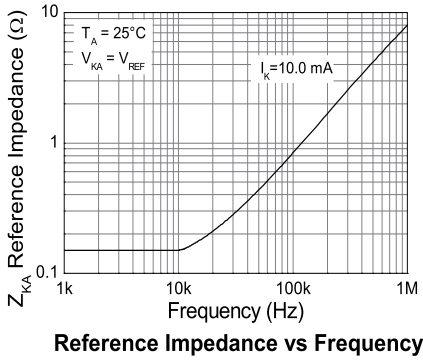
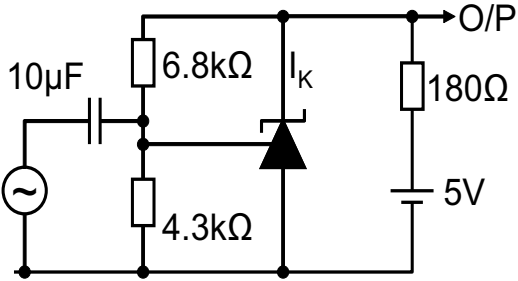
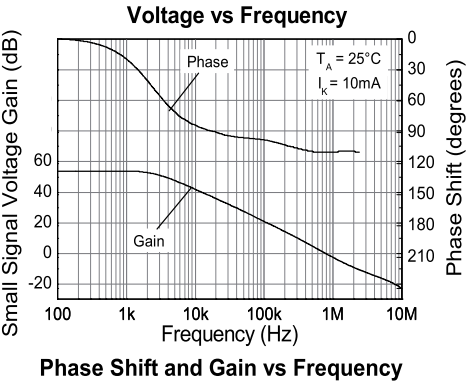
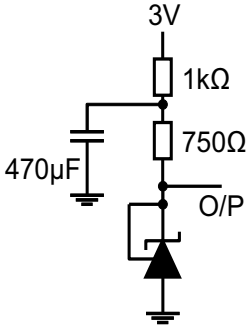
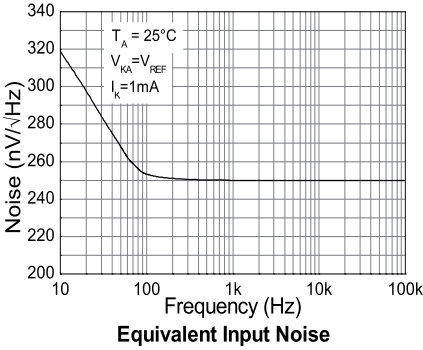

I_K	0.1mA	1-15mA
R1	1kΩ	100Ω
R2	1kΩ	100Ω

Typical Characteristics

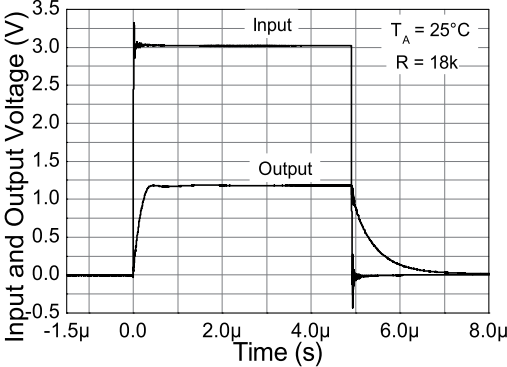

Pulse Response

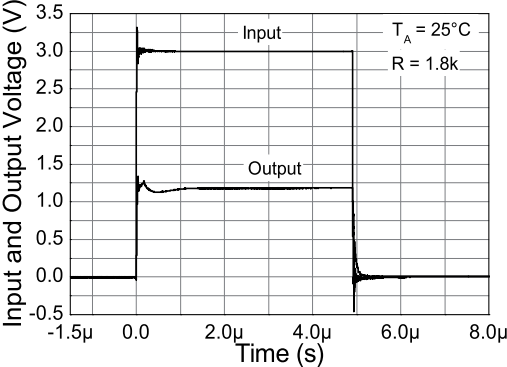
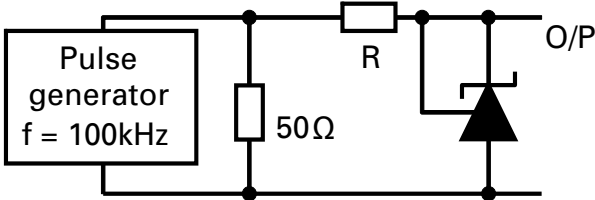

Pulse Response

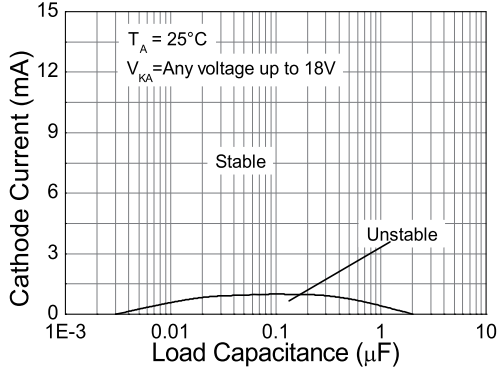

Stability Boundary Condition

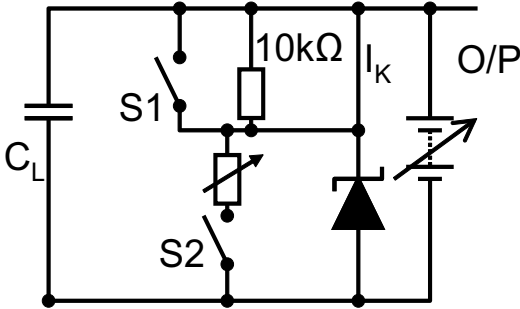

Application information

In a conventional shunt regulator application (*Figure 1*), an external series resistor (R_3) is connected between the supply voltage and the TLV431. R_3 determines the current that flows through the load (I_L) and the TLV431 (I_K). The TLV431 will adjust how much current it sinks or “shunts” to maintain a voltage equal to V_{REF} across its feedback pin. Since load current and supply voltage may vary, R_3 should be small enough to supply at least the minimum acceptable I_{KMIN} to the TLV431 even when the supply voltage is at its minimum and the load current is at its maximum value. When the supply voltage is at its maximum and I_L is at its minimum, R_3 should be large enough so that the current flowing through the TLV431 is less than 15 mA. R_3 is determined by the supply voltage, (V_{IN}), the load and operating current, (I_L and I_K), and the TLV431’s reverse breakdown voltage, V_{KA} .

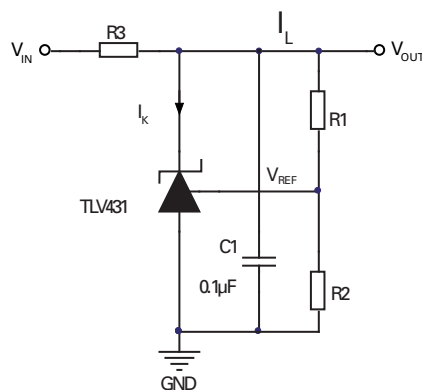

$$R_3 = \frac{V_S - V_{KA}}{I_L + I_K}$$

where

$$V_{KA} = V_{REF} \times \left(1 + \frac{R_1}{R_2} \right)$$

and $V_{KA} = V_{OUT}$

Figure 1. Basic shunt regulator

The values of R_1 and R_2 should be large enough so that the current flowing through them is much smaller than the current through R_3 yet not too large that the voltage drop across them caused I_{REF} affects the reference accuracy.

The most frequent application of the TLV431 is in isolated low output voltage power supplies where the regulated output is galvanically isolated from the controller. As shown in figure 2 the TLV431 drives current, I_F , through the opto-coupler’s LED which in turn drives the isolated transistor which is connected to the controller on the primary side of the power supply. This completes the feedback path through the isolation barrier and ensures that a stable isolated supply is maintained. Assuming a forward drop of 1.4V across the opto-coupler diode allows output voltages as low as 2.7V to be regulated.

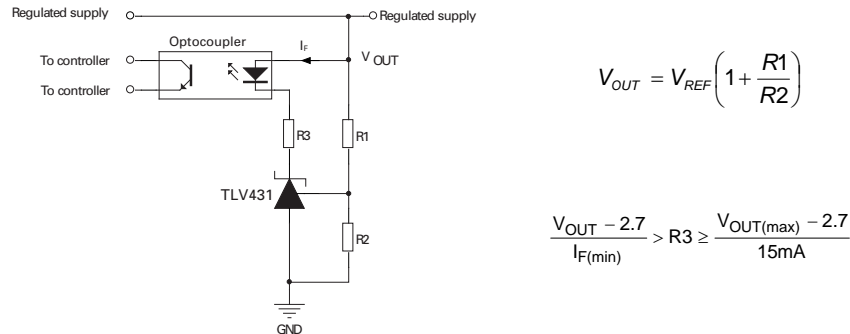

Figure 2. Using the TLV431 as the regulating element in an isolated PSU

Printed circuit board layout considerations

The TLV431 in the SOT23-5 package has the die attached to pin 2, which results in an electrical contact between pin 2 and pin 5. Therefore, pin 2 of the SOT23-5 package must be left floating or connected to pin 5. TLV431 in the SC70-6 package has the die attached to pin 2 and 5, which results in an electrical contact between pins 2, 5 and pin 6. Therefore, pins 2 and 5 must be left floating or connected to pin 6.

Other applications of TLV431

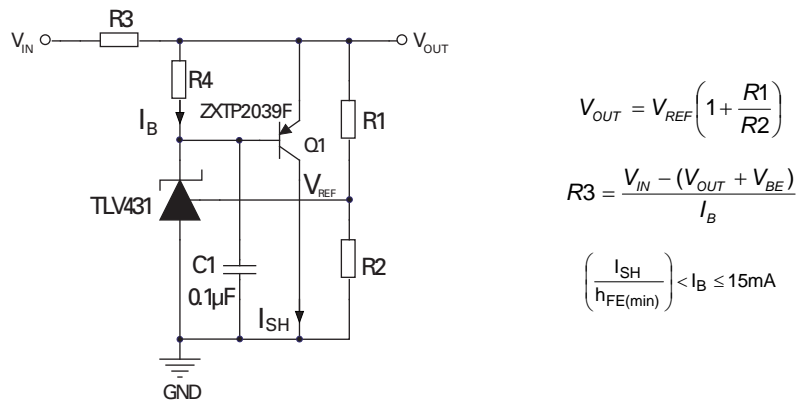

Figure 3. High current shunt regulator

It may at times be required to shunt-regulate more current than the 15mA that the TLV431 is capable of.

Figure 3 shows how this can be done using transistor Q1 to amplify the TLV431's current. Care needs to be taken that the power dissipation and/or SOA requirements of the transistor is not exceeded

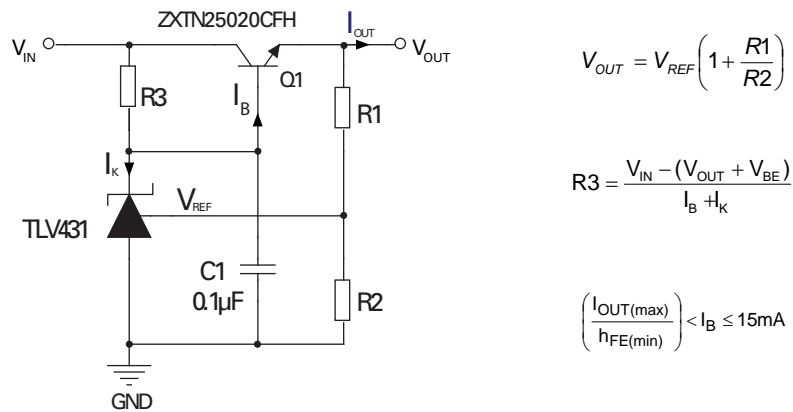

Figure 4. Basic series regulator

A very effective and simple series regulator can be implemented as shown in Figure 4 above. This may be preferable if the load requires more current than can be provided by the TLV431 alone and there is a need to conserve power when the load is not being powered. This circuit also uses one component less than the shunt circuit shown in Figure 2 above.

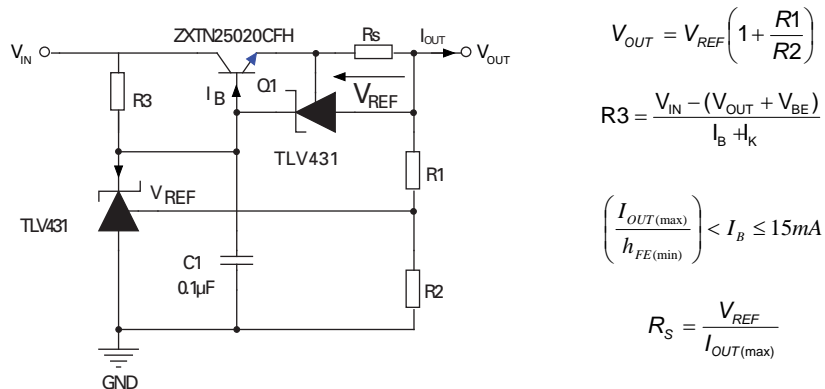
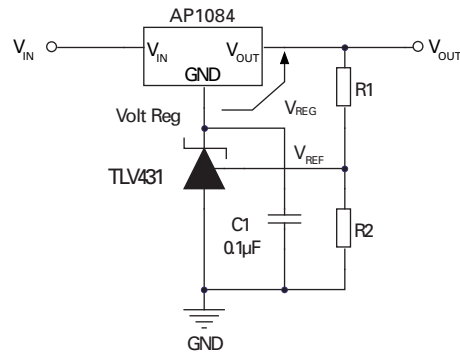

Figure 5. Series regulator with current limit

Figure 5 adds current limit to the series regulator in Figure 4 using a second TLV431. For currents below the limit, the circuit works normally supplying the required load current at the design voltage. However should attempts be made to exceed the design current set by the second TLV431, the device begins to shunt current away from the base of Q1. This begins to reduce the output voltage and thus ensuring that the output current is clamped at the design value. Subject only to Q1's ability to withstand the resulting power dissipation, the circuit can withstand either a brief or indefinite short circuit.



$$V_{OUT} = V_{REF} \left(1 + \frac{R1}{R2} \right)$$

$$V_{OUT} \geq (V_{REG} + V_{REF})$$

(All features of the regulator such as short circuit protection, thermal shutdown, etc, are maintained.)

Figure 6. Increasing output voltage of a fixed linear regulator

One of the useful applications of the TLV431 is in using it to improve the accuracy and/or extend the range and flexibility of fixed voltage regulators. In the circuit in Figure 6 above, both the output voltage and its accuracy are entirely determined by the TLV431, R1 and R2. However the rest of the features of the regulator (up to 5A output current, output current limiting and thermal shutdown) are all still available.

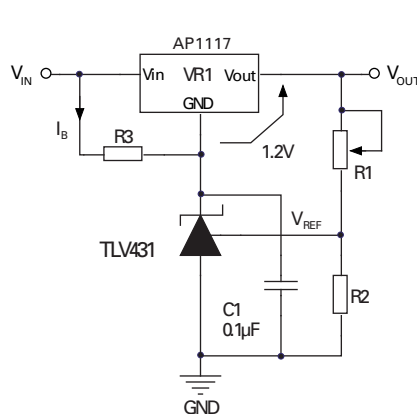

$$V_{OUT} = V_{REF} \left(1 + \frac{R1}{R2} \right)$$

$$V_{OUT} \geq (V_{REG} + V_{REF})$$

$$R3 = \frac{V_{IN} - (V_{OUT} - V_{REG})}{I_B}$$

$$0.1mA \leq I_B \leq 15mA$$

(All features of the regulator such as short circuit protection, thermal shutdown, etc, are maintained.)

Figure 7. Adjustable linear voltage regulator

Figure 7 is similar to Figure 6 with adjustability added. Note the addition of R3. This is only required for the AP1117 due to the fact that its ground or adjustment pin can only supply a few micro-Amps of current at best. R3 is therefore needed to provide sufficient bias current for the TLV431.

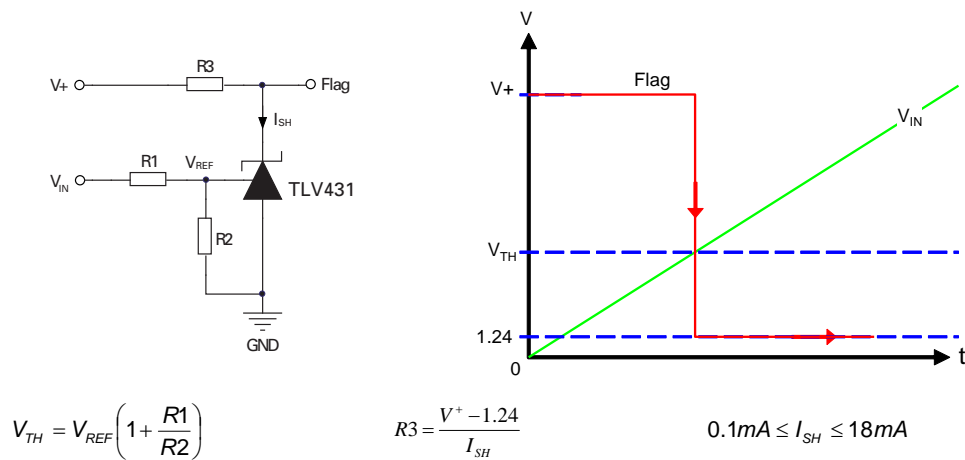
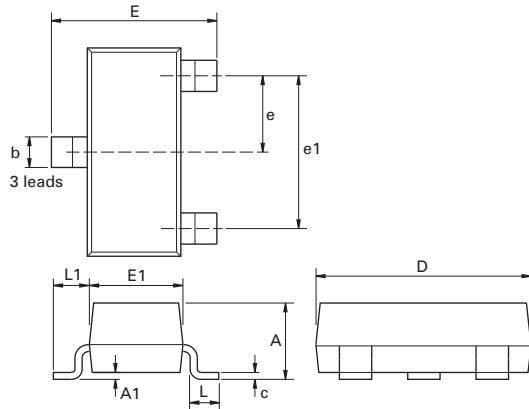

Figure 8. Using the TLV431 as a level detector

In its open loop state, the TLV431 is analogous to a line-powered comparator with its non-inverting input internally connected to a 1.24V reference voltage. This means the remaining inverting input can be used for comparator functions.

Figure 8 above shows the TLV431 being used as a level comparator. Its output (Flag) is normally high and goes low when the input reaches or exceeds the threshold (V_{TH}) determined by R1 and R2.

Package Outline - SOT23



SOT23-5

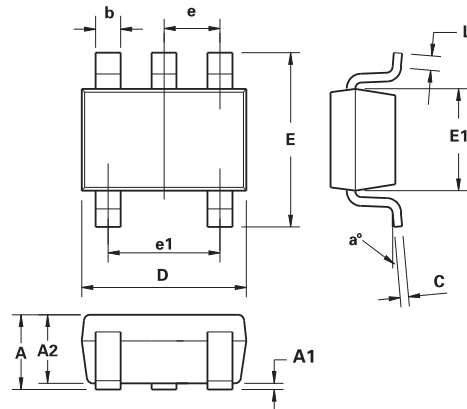

Dimension Table SOT23

Dim.	Millimeters		Inches		Dim.	Millimeters		Inches	
	Min.	Max.	Min.	Max.		Min.	Max.	Min.	Max.
A	-	1.12	-	0.044	e1	1.90 NOM		0.075 NOM	
A1	0.01	0.10	0.0004	0.004	E	2.10	2.64	0.083	0.104
b	0.30	0.50	0.012	0.020	E1	1.20	1.40	0.047	0.055
c	0.085	0.20	0.003	0.008	L	0.25	0.60	0.0098	0.0236
D	2.80	3.04	0.110	0.120	L1	0.45	0.62	0.018	0.024
e	0.95 NOM		0.037 NOM		-	-	-	-	-

Note: Controlling dimensions are in millimeters. Approximate dimensions are provided in inches

Dimension table - SOT23-5

Dim.	Millimeters		Inches		Dim.	Millimeters		Inches	
	Min.	Max.	Min.	Max.		Min.	Max.	Min.	Max.
A	0.9	1.45	0.0354	0.0570	E	2.20	3.20	0.0866	0.1181
A1	0.00	0.15	0.00	0.0059	E1	1.30	1.80	0.0511	0.0708
A2	0.90	1.3	0.0354	0.0511	e	0.95 REF		0.0374	
b	0.20	0.50	0.0078	0.0196	e1	1.90 REF		0.0748	
C	0.09	0.26	0.0035	0.0102	L	0.10	0.60	0.0039	0.0236
D	2.70	3.10	0.1062	0.1220	a°	0	30	0	30

Note: Controlling dimensions are in millimeters. Approximate dimensions are provided in inches

Package outline - SC70-6

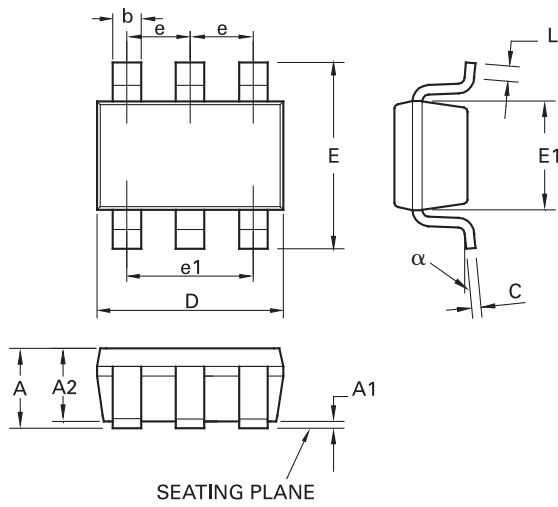

Dim.	Millimeters		Inches		Dim.	Millimeters		Inches	
	Min.	Max.	Min.	Max.		Min.	Max.	Min.	Max.
A	0.80	1.10	0.0315	0.0433	E	2.10 BSC		0.0826 BSC	
A1	0	0.10	0	0.0039	E1	1.25 BSC		0.0492 BSC	
A2	0.80	1.00	0.0315	0.0394	e	0.65 BSC		0.0255 BSC	
b	0.15	0.30	0.006	0.0118	e1	1.30 BSC		0.0511 BSC	
C	0.08	0.25	0.0031	0.0098	L	0.26	0.46	0.0102	0.0181
D	2.00 BSC		0.0787 BSC		a°	0	8	0	8

Note: Controlling dimensions are in millimeters. Approximate dimensions are provided in inches

Intentionally left blank

Definitions

Product change

Zetex Semiconductors reserves the right to alter, without notice, specifications, design, price or conditions of supply of any product or service. Customers are solely responsible for obtaining the latest relevant information before placing orders.

Applications disclaimer

The circuits in this design/application note are offered as design ideas. It is the responsibility of the user to ensure that the circuit is fit for the user's application and meets with the user's requirements. No representation or warranty is given and no liability whatsoever is assumed by Zetex with respect to the accuracy or use of such information, or infringement of patents or other intellectual property rights arising from such use or otherwise. Zetex does not assume any legal responsibility or will not be held legally liable (whether in contract, tort (including negligence), breach of statutory duty, restriction or otherwise) for any damages, loss of profit, business, contract, opportunity or consequential loss in the use of these circuit applications, under any circumstances.

Life support

Zetex products are specifically not authorized for use as critical components in life support devices or systems without the express written approval of the Chief Executive Officer of Zetex Semiconductors plc. As used herein:

A. Life support devices or systems are devices or systems which:

1. are intended to implant into the body

or

2. support or sustain life and whose failure to perform when properly used in accordance with instructions for use provided in the labelling can be reasonably expected to result in significant injury to the user.

B. A critical component is any component in a life support device or system whose failure to perform can be reasonably expected to cause the failure of the life support device or to affect its safety or effectiveness.

Reproduction

The product specifications contained in this publication are issued to provide outline information only which (unless agreed by the company in writing) may not be used, applied or reproduced for any purpose or form part of any order or contract or be regarded as a representation relating to the products or services concerned.

Terms and Conditions

All products are sold subjects to Zetex' terms and conditions of sale, and this disclaimer (save in the event of a conflict between the two when the terms of the contract shall prevail) according to region, supplied at the time of order acknowledgement.

For the latest information on technology, delivery terms and conditions and prices, please contact your nearest Zetex sales office.

Quality of product

Zetex is an ISO 9001 and TS16949 certified semiconductor manufacturer.

To ensure quality of service and products we strongly advise the purchase of parts directly from Zetex Semiconductors or one of our regionally authorized distributors. For a complete listing of authorized distributors please visit: www.zetex.com/salesnetwork

Zetex Semiconductors does not warrant or accept any liability whatsoever in respect of any parts purchased through unauthorized sales channels.

ESD (Electrostatic discharge)

Semiconductor devices are susceptible to damage by ESD. Suitable precautions should be taken when handling and transporting devices. The possible damage to devices depends on the circumstances of the handling and transporting, and the nature of the device. The extent of damage can vary from immediate functional or parametric malfunction to degradation of function or performance in use over time. Devices suspected of being affected should be replaced.

Green compliance

Zetex Semiconductors is committed to environmental excellence in all aspects of its operations which includes meeting or exceeding regulatory requirements with respect to the use of hazardous substances. Numerous successful programs have been implemented to reduce the use of hazardous substances and/or emissions.

All Zetex components are compliant with the RoHS directive, and through this it is supporting its customers in their compliance with WEEE and ELV directives.

Product status key:

"Preview"	Future device intended for production at some point. Samples may be available
"Active"	Product status recommended for new designs
"Last time buy (LTB)"	Device will be discontinued and last time buy period and delivery is in effect
"Not recommended for new designs"	Device is still in production to support existing designs and production
"Obsolete"	Production has been discontinued

Datasheet status key:

"Draft version"	This term denotes a very early datasheet version and contains highly provisional information, which may change in any manner without notice.
"Provisional version"	This term denotes a pre-release datasheet. It provides a clear indication of anticipated performance. However, changes to the test conditions and specifications may occur, at any time and without notice.
"Issue"	This term denotes an issued datasheet containing finalized specifications. However, changes to specifications may occur, at any time and without notice.

Zetex sales offices

Europe	Americas	Asia Pacific	Corporate Headquarters
Zetex GmbH Kustermann-Park Balanstraße 59 D-81541 München Germany Telephone: (49) 89 45 49 49 0 Fax: (49) 89 45 49 49 49 europe.sales@zetex.com	Zetex Inc 700 Veterans Memorial Highway Hauppauge, NY 11788 USA Telephone: (1) 631 360 2222 Fax: (1) 631 360 8222 usa.sales@zetex.com	Zetex (Asia Ltd) 3701-04 Metroplaza Tower 1 Hing Fong Road, Kwai Fong Hong Kong Telephone: (852) 26100 611 Fax: (852) 24250 494 asia.sales@zetex.com	Zetex Semiconductors plc Zetex Technology Park, Chadderton Oldham, OL9 9LL United Kingdom Telephone: (44) 161 622 4444 Fax: (44) 161 622 4446 hq@zetex.com

© 2008 Published by Zetex Semiconductors plc