

Duratool Tools of the Trade

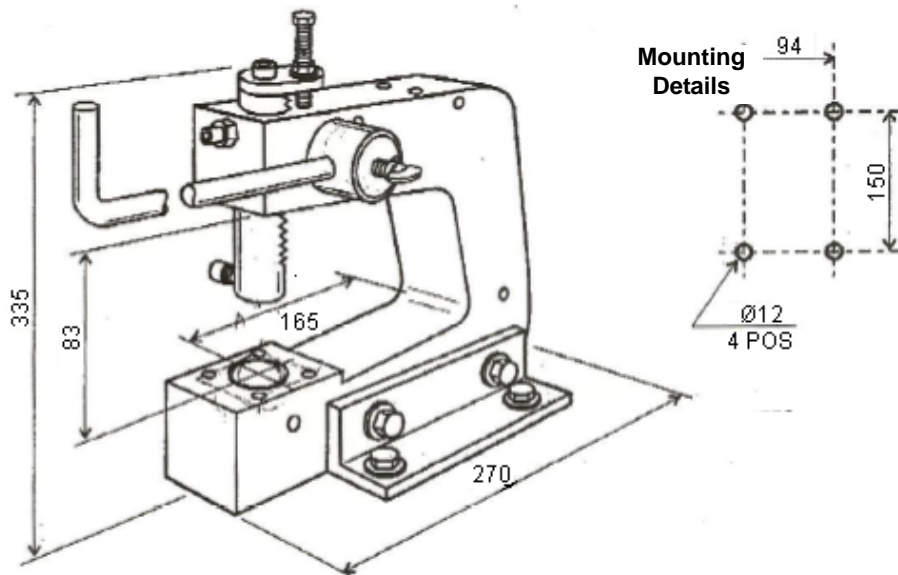

3000LB Lever Press

Dimensions



Dimensions : Millimetres

Features:

- Length (overall) : 270 mm
- Height (max excl lever) : 335 mm
- Width (incl mtg brackets) : 165 mm
- Handle length : 550 mm
- Throat depth : 150 mm
- Clearance : 83 mm
- Stroke length : 6 to 60 mm
- Ram spigot hole dia. : 18 mm
- Depth : 22 mm
- Base central hole dia. : 38 mm
- Mounting holes : 4 x 12 mm
- Press weight : 14.5 Kg

Capacity

- Fibreglass : 2 mm
- Paper PCB (s.r.b.p.) : 3.2 mm
- Aluminium : 2.5 mm
- Mild steel : 1.6 mm

Description

A bench mounting, hand operated lever press, which together with a variety of punching, cutting and forming tool accessories, provides a universal service for sheet metal working in both workshop and production environments.

Constructed from high quality carbon steel, with a stove enamel finish, and preclusion machined rack and pinion, a constant pressure through the complete stroke up to 3000 lbs is achievable. Easy to set up and operate, the press features an adjustable screw to limit the ram downwards movement, and a lever with lockable length and angle adjustment.

Part Number Table

Description	Part Number
3000LB Lever Press	900-0000

Important Notice : This data sheet and its contents (the "Information") belong to the members of the Premier Farnell group of companies (the "Group") or are licensed to it. No licence is granted for the use of it other than for information purposes in connection with the products to which it relates. No licence of any intellectual property rights is granted. The Information is subject to change without notice and replaces all data sheets previously supplied. The Information supplied is believed to be accurate but the Group assumes no responsibility for its accuracy or completeness, any error in or omission from it or for any use made of it. Users of this data sheet should check for themselves the Information and the suitability of the products for their purpose and not make any assumptions based on information included or omitted. Liability for loss or damage resulting from any reliance on the Information or use of it (including liability resulting from negligence or where the Group was aware of the possibility of such loss or damage arising) is excluded. This will not operate to limit or restrict the Group's liability for death or personal injury resulting from its negligence. DURATOOL is the registered trademark of the Group. © Premier Farnell plc 2011.

www.element14.com
www.farnell.com
www.newark.com
www.cpc.co.uk
www.mcmelectronics.com

