

Farnell Order Code: 1538968

FOX MODEL: FXO-PC535R-155.52

FOX Part Number: 773-155.52-5

LVPECL, CERAMIC, SMD, OSCILLATOR

A. Specifications

Parameters	
Frequency	155.52 MHz
Frequency Stability ¹	±50PPM
Temperature Range	
Operating (T _{OPR})	-40°C ~ +85°C
Storage (T _{STG})	-55°C ~ +125°C
Supply Voltage (V _{DD})	3.3V ± 5%
Input Current (I _{DD})	120 mA Max
Output Voltage (V _{OL})	1.305V ~ 1.65V
(V _{OH})	2.055V ~ 2.405V
Output Symmetry (50% V _{p-p} Level)	45% ~ 55%
Rise Time (20% ~ 80% V _{p-p}) (TR)	400 pS Max
Fall Time (80% ~ 20% V _{p-p}) (TF)	400 pS Max
Output Load (Recommended Circuit below)	50 ohms into +1.3V
Startup Time (T _S)	10 ms Max
Output Enable / Disable Time ²	100 nS Max
Phase Jitter (12kHz ~ 20MHz)	0.92 pS Typ.
Maximum Soldering Temp / Time	260°C / 10 Seconds
Moisture Sensitivity Level (MSL)	1
Termination Finish	Au

¹ Inclusive of 25°C tolerance, operating temperature range, input voltage change, load change, aging, shock, and vibration.

² An internal pullup resistor from pin 1 to pin 6 allows active output if pin 1 is left open.

ENABLE/DISABLE FUNCTION ²	
Pin 1	OUTPUT (Pin 4, 5)
OPEN ⁴	ACTIVE
'1' Level V _{IH} ≥ 70%V _{DD}	ACTIVE
'0' Level V _{IL} ≤ 30%V _{DD}	High Z

NOTE A 0.01µF bypass capacitor should be placed between V_{DD} (Pin6) and GND (Pin 3) to minimize power supply line noise.

RoHS Compliance Status: Compliant



Drawing is for reference to critical specifications defined by size measurements. Certain non-critical visual attributes, such as side castellations, reference pin shape, etc. may vary

B. Mechanical / Dimensions (millimeters):

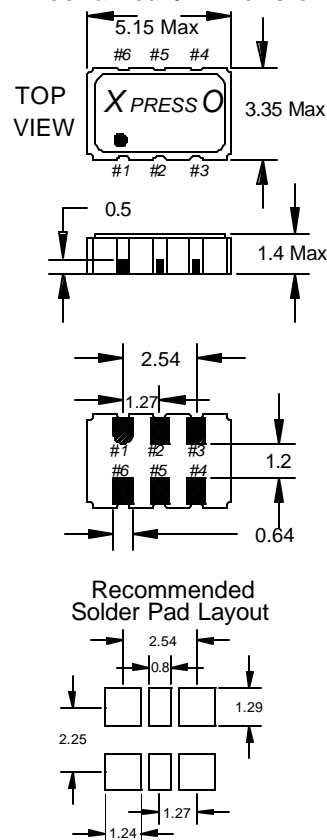

Pin Connections

- #1 E/D
- #2 NC
- #3 GND
- #4 Output 1
- #5 Output 2
- #6 V_{DD}

C. Recommended Circuit

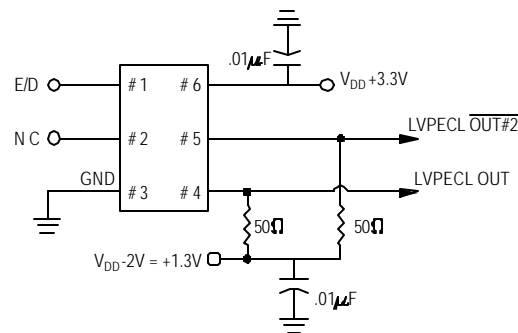

NOTE: The above specifications, having been carefully prepared and checked, is believed to be accurate at the time of publication; however, no responsibility is assumed by Fox Electronics for inaccuracies.

Reference / Comments	Title / Description: Product Specifications		
	Drawing Number: DWG-4552-3	Rev: 1	Size: A
	Part Number: 773-155.52-5		Cage: 61429
	Draftsperson: AR	Approved: BN	Date: 01/15/2008