

WIRING DIAGRAMS

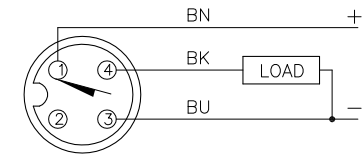

OUTPUT: AP6X

SHORT-CIRCUIT AND OVERLOAD PROTECTED

LOCKNUT LN-M30

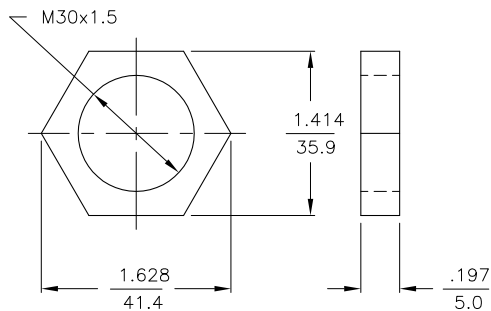

SPECIFICATIONS

RATED OPERATING DISTANCE	30mm = 1.181"
MOUNTING MODE	NON-FLUSH
MIN. REPEAT ACCURACY	≤ 2%
TEMPERATURE DRIFT	≤ ±10% ≤ ±15%, ≤ -25°C v ≥ +70°C
HYSTERESIS	3-15%
OPERATING TEMPERATURE	-30°C to +85°C (-22°F to +185°F)
RATED OPERATIONAL VOLTAGE	10-30 VDC
RESIDUAL RIPPLE	≤ 10%
DC RATED OPERATIONAL CURRENT	≤ 200 mA
NO-LOAD CURRENT	≤ 15 mA
RESIDUAL CURRENT	≤ 0.1 mA
RATED INSULATION VOLTAGE	≤ 0.5 kV
SHORT-CIRCUIT PROTECTION	YES
MAX. VOLTAGE DROP	≤ 1.8 V
WIRE BREAKAGE PROTECTION	INCORPORATED
REVERSE POLARITY PROTECTION	INCORPORATED
OUTPUT FUNCTION	3-WIRE, NORMALLY OPEN, PNP
MAX. SWITCHING FREQUENCY	≤ 0.5 kHz
HOUSING MATERIAL	METAL, BRASS/CHROME-PLATED
ACTIVE FACE MATERIAL	PLASTIC, LCP-GF30
CONNECTION	M12x1
VIBRATION RESISTANCE	55 Hz, 1 mm AMPLITUDE (IN ALL 3 PLANES)
SHOCK RESISTANCE	30 g, 11 ms
DEGREE OF PROTECTION	IP68
SWITCHING STATUS INDICATION	LED, YELLOW

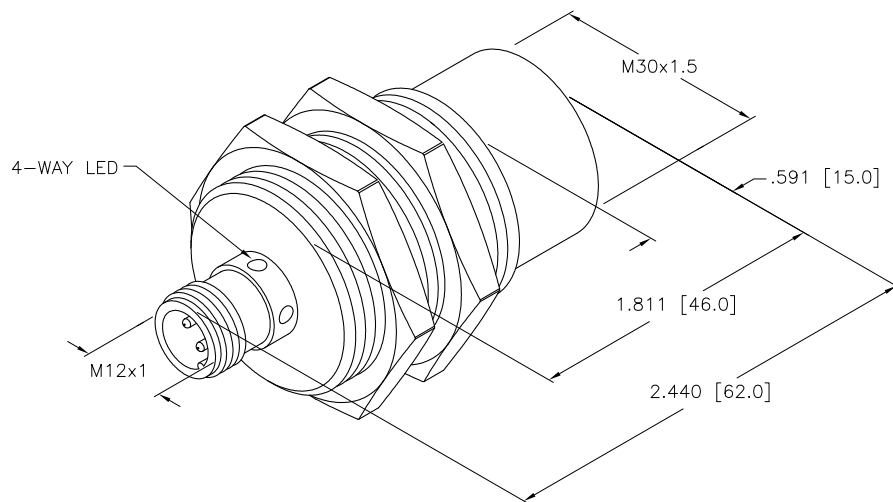

SOURCE DRAWING - FOR REFERENCE ONLY

NOTES:

1. UPROX HAS WELD FIELD IMMUNITY, SENSOR IS SUITABLE FOR USE ON RESISTANCE MACHINES.

RELATED DOCUMENTS 1. 2. 3. 4.	3RD ANGLE PROJECTION 	THIS DRAWING IS PROPERTY OF TURCK INC. USE OF THIS DOCUMENT WITHOUT WRITTEN PERMISSION IS PROHIBITED.		<b>TURCK INC</b> High Technology Sensors and Automation Controls 3000 CAMPUS DRIVE MINNEAPOLIS, MN 55441 1-800-544-7769 (763) 553-7300 (763) 553-0708 fax turck.com	
	MATERIAL	DRFT RDS	DATE 09/13/07	DESCRIPTION NI30U-M30-AP6X-H1141	
FINISH	ALL DIMENSIONS DISPLAYED ON THIS DRAWING ARE FOR REFERENCE ONLY	DSGN AF	SCALE 1=1.0	IDENTIFICATION NO. M1646631	
CONTACT TURCK FOR MORE INFORMATION		UNIT OF MEASUREMENT <b>INCH [ MILLIMETER ]</b>		REV A	
DO NOT SCALE THIS DRAWING		FILE: M1646631		SHEET 1 OF 1	

A	DRAWING RELEASE	RDS	09/13/07	
REV	DESCRIPTION	BY	DATE	ECO NO.