

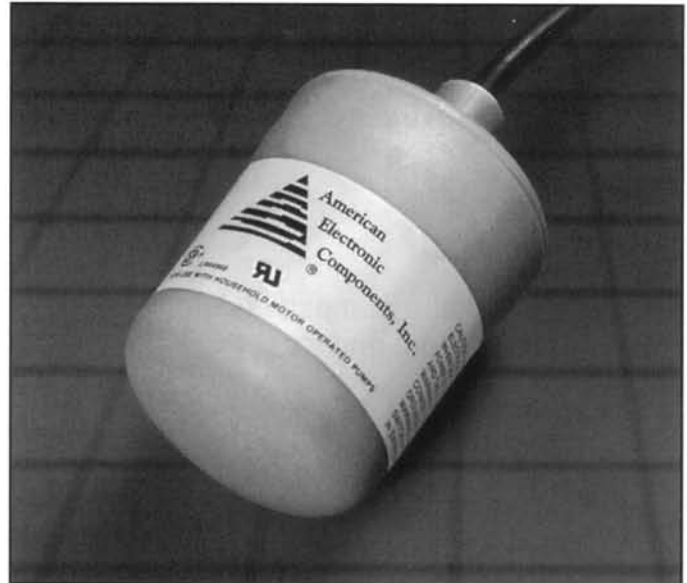

## Mechanical Float Switch

Custom-designed float switch for liquid level control. Designed for use with liquid level warning alarms, pilot duty control of simplex or duplex systems, sump pumps, or any type of high/low operation. Available with standard power cords or custom cords with quick-connect plugs, these floats can serve as original equipment components, retrofit, or as replacement parts.



Part #	Action	Length	Termination	Angle
FCSA3710/20	Open	10/20ft	Blunt Cut	85°
FCSB3710/20	Closed	10/20ft	Blunt Cut	85°
FCSA1710/20	Open	10/20ft	120VAC Plug	85°
FCSB1710/20	Closed	10/20ft	120VAC Plug	85°
FCNA3710/20	Open	10/20ft	Blunt Cut	45°
FCNB3710/20	Closed	10/20ft	Blunt Cut	45°
FCNA1710/20	Open	10/20ft	120VAC Plug	45°
FCNB1710/20	Closed	10/20ft	120VAC Plug	45°

### Float Switch Part Number System

Example

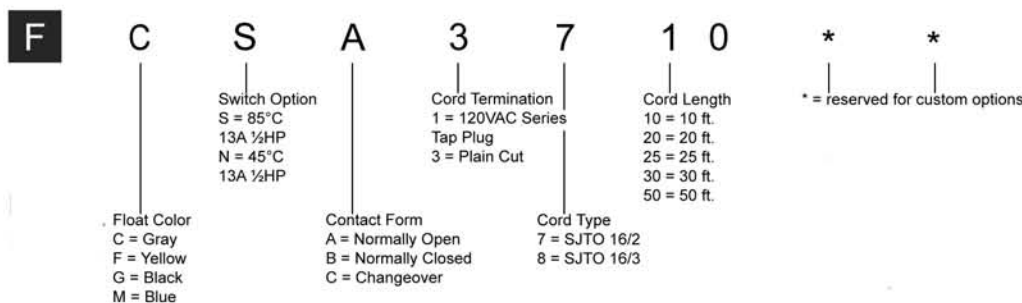

Contact factory for standard part numbers, custom floats or specific float application information.

U.L & C.S.A. listed for 13A, FLA 13A, LRA 43A, and 0.5Hp @ 120/240VAC.

Floats are for use with motor-operated water pumps only, not for swimming pool use.

Recommended operating temperature range is 32°F to 160°F (0°C to 71°C).

## Mechanical Float Switch

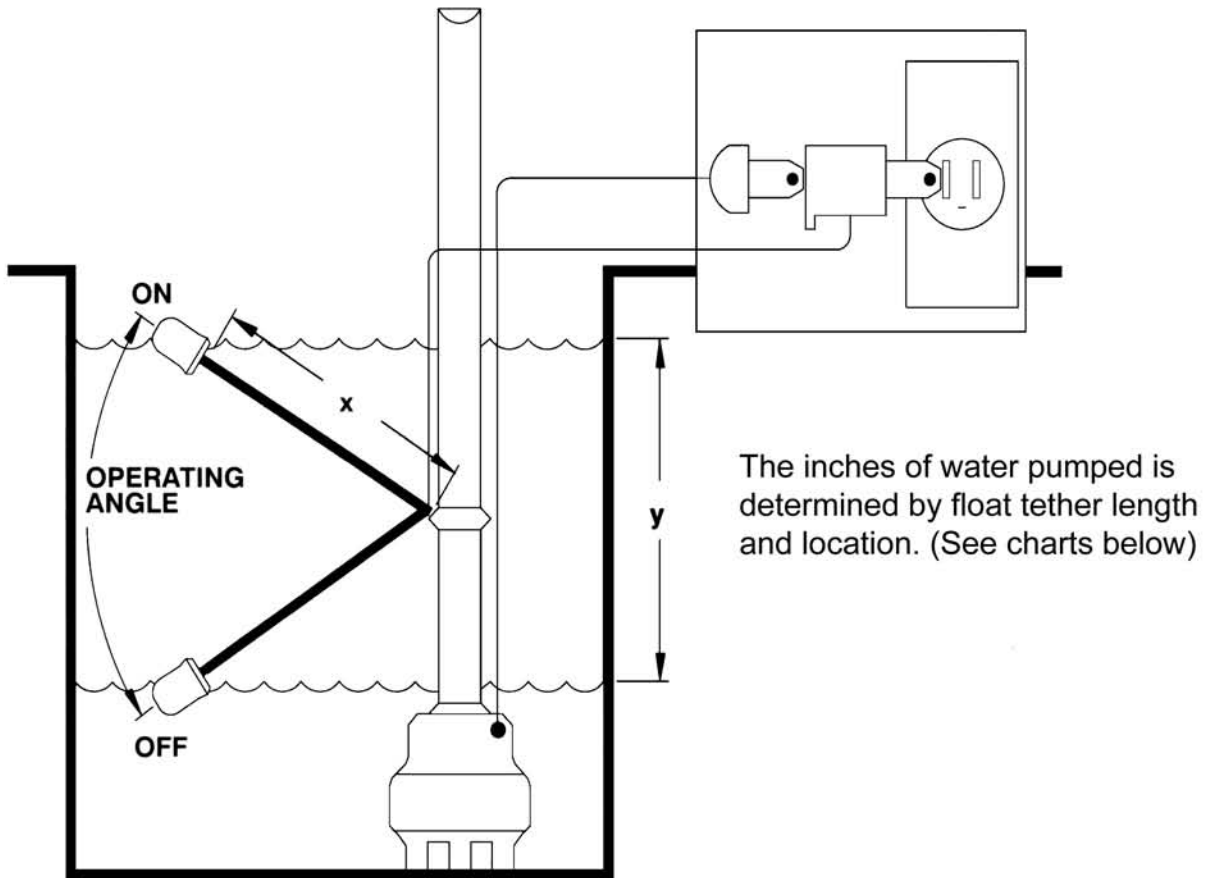

### Wide Angle 85°

Tether length, inches (x)	3	4	6	8	10	12
Water pumped, inches (y)	7	8	11	14	17	21

### Narrow Angle 45°

Tether length, inches (x)	3	4	6	8
Water pumped, inches (y)	3.5	4.5	5.5	6

U.L. # E87187  
C.S.A. # LR64966