

RFID board datasheet EB052-00-1

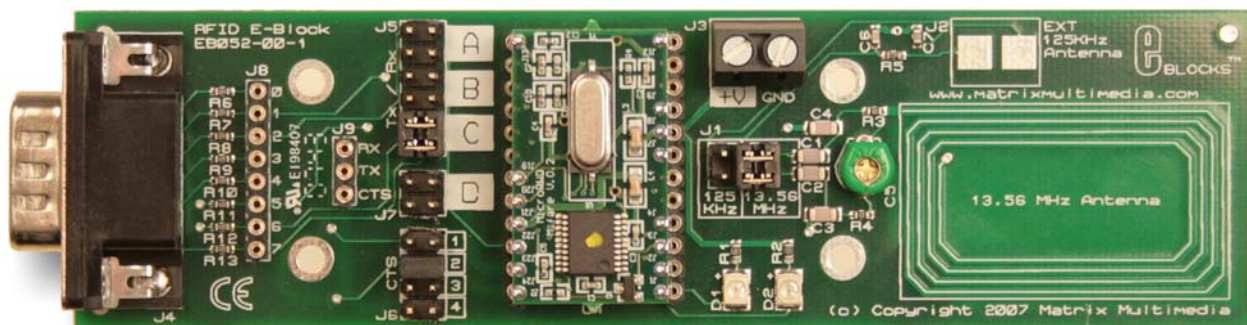

Contents

1.	About this document.....	2
2.	General information.....	3
3.	Board layout	5
4.	Testing this product	6
5.	Circuit description	7

Appendix 1 Circuit diagram

1. About this document

This document concerns the E-blocks RFID board code EB052 version 1.

The order code for this product is EB052.

1. Trademarks and copyright

PIC and PICmicro are registered trademarks of Arizona Microchip Inc.
E-blocks is a registered trademark of Matrix Multimedia Limited.

2. Other sources of information

There are various other documents and sources that you may find useful:

Getting started with E-Blocks.pdf EB355

This describes the E-blocks system and how it can be used to develop complete systems for learning electronics and for PICmicro programming.

3. Disclaimer

The information in this document is correct at the time of going to press. Matrix Multimedia reserves the right to change specifications from time to time. This product is for development purposes only and should not be used for any life-critical application.

4. Technical support

If you have any problems operating this product then please refer to the testing section of this document first. You will find the latest software updates, FAQs and other information on our web site: www.matrixmultimedia.com . If you still have problems please email us at: support@matrixmultimedia.co.uk.

2. General information

1. Description

The EB052 RFID E-Block provides a RFID interface that can communicate with all common RFID devices running at either 125KHz or 13.56MHz. RFID stands for Radio Frequency IDentifier. RFID is a means of tagging items such as stock items. A good example of this is the use of RFID in stores to detect theft. The RFID E-Block interfaces RFID devices, also known as 'tags', through a high frequency radio wave. This radio frequency burst acts as a dual function: to simultaneously provide power to the RFID device, and to communicate with the device. RFID devices or tags can have internal peripherals such as EEPROM, Flash and can even encrypt data to industrial standards.

2. Features

- RFID Wireless communications
- Flowcode macros available
- 125KHz or 13.56MHz operating frequency (125KHz RFID Module and Antenna available separately)
- Onboard 13.56MHz PCB Antenna
- Status LEDs
- Tuning Capacitors
- Range of approx 10cm

3. RFID Compatibility

13.56MHz RWD-ICODE RFID Module (module supplied as standard)

Transponder Type	Memory size (total / user)	Baud Rate	Security	Key Features
MIFARE 1K	1024 / 768	Up to 106K	Yes	R/W Secure, card, payment, access
MIFARE 4K	4096 / 3456	Up to 106K	Yes	R/W Secure, card, payment, access
Ultralight	64 / 48	Up to 106K	No	R/W Low cost, payment
ICODE SLI	128 / 112	Up to 53K	No	R/W Low cost, asset tracking, smart labels

125KHz RWD-QT (module sold separately)

Transponder Type	Memory size (total / user)	Baud Rate	Security	Key Features
HITAG 1	256 / 192	Up to 4K	Yes	R/W General purpose
HITAG S256/2048	256 / 256	Up to 4K	Yes	R/W General purpose
HITAG 2	32 / 16	Up to 4K	Yes	R/W Secure access, asset tracking
EM4001/4102	8 / 5	Up to 4K	No	R Access control
MCRF200/123	16 / 14	Up to 4K	No	R Access control

Note: To use the 125KHz RFID devices you must order a separate 125KHz RFID module and external antenna.

4. 3.3V system compatibility

The RFID board requires a 5V supply.

5. Communications

The RFID modules are configured by means of using a TTL level RS232 bus. This protocol requires a start bit, eight data bits and a stop bit.

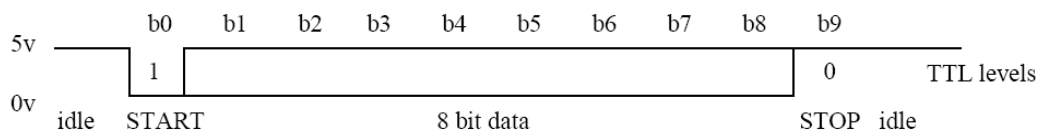

The baud rate for the modules is set to 9600, with no parity, and there is also a flow control, CTS, line that can be used.

Here is a functional diagram of the timing required by the RFID modules. The module is ready to receive data when the CTS line drops to logic zero. After sending the data you have to then wait at least 100ms before data will be transmitted back from the module.

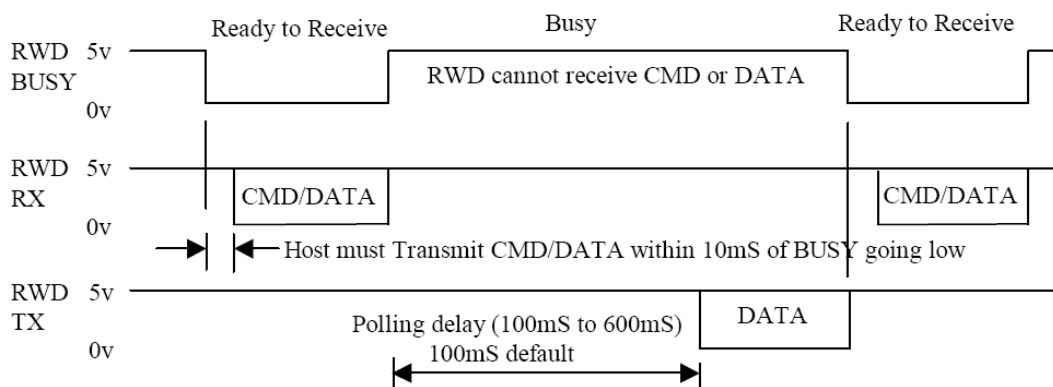

6. Device Command overview

13.56MHz RWD-ICODE RFID Module (module supplied as standard)

Command	Command Data	Data 1	Data 2	Data 3	Data 4	Data 5	Data 6	Data 7	Acknowledge
Card / Label Status	0x53	N/A	N/A	N/A	N/A	N/A	N/A	N/A	1FFFFFFX
Message Report	0x7A	N/A	N/A	N/A	N/A	N/A	N/A	N/A	Product and Firmware string
Write EEPROM	0x50	EEPROM Address	EEPROM Data	N/A	N/A	N/A	N/A	N/A	1XXXXXXF
Store Key	0x4B	Key Code (0 - 31)	LS Byte	Byte 2	Byte 3	Byte 4	Byte 5	MS Byte	1XXXXXXF

The status flags returned by the acknowledge byte are as follows.

```

b7 b6 b5 b4 b3 b2 b1 b0
1  1  1  1  1  1  1  1
|  |  |  |  |  |  |  |
|  |  |  |  |  |  |  | EEPROM error (Internal EEPROM write error)
|  |  |  |  |  |  |  | Card OK (Card serial number matched to identity code list)
|  |  |  |  |  |  |  | Rx OK (Card communication and acknowledgement OK)
|  |  |  |  |  |  |  | RS232 error (Host serial communication error)
|  |  |  |  |  |  |  | MF type (0 = MF 1k byte card, 1 = MF 4k byte card)
|  |  |  |  |  |  |  | UL type (0 = MF standard 1k/4k card, SINGLE UID), 1 = MF Ultralight card, DOUBLE UID)
|  |  |  |  |  |  |  | MFRC error (Internal or antenna fault)

```

More commands can be found in the RFID module datasheet.

3. Board layout

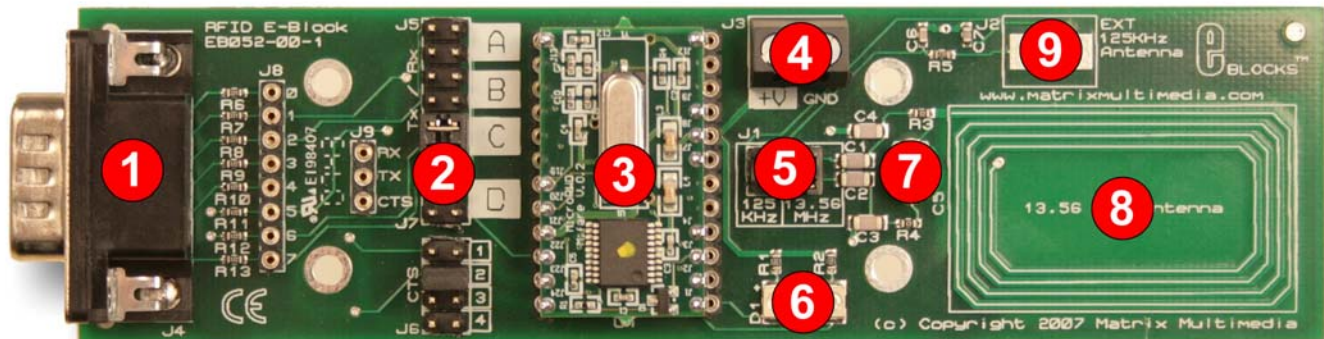

EB052-74-1.cdr

- 1) 9 Way D-type Plug
- 2) Patch system
- 3) RFID Module
- 4) Power Terminals
- 5) Frequency / Antenna Select
- 6) Status LEDs
 1. Red LED Flashing – Antenna needs tuning
 2. Red LED Stable – Antenna tuned correctly
 3. Green LED Stable – RFID device detected and connected
- 7) Sensitivity Tuning Capacitor
- 8) Onboard 13.56MHz Antenna
- 9) External 125KHz Antenna connector (not fitted as standard)

4. Testing this product

The following program will test the circuit. The test file can be downloaded from www.matrixmultimedia.com.

1. System Setup

Multi-programmer board (EB006) with:

EB006 Options	Setting
Power supply	External, 14V
PICmicro device	16F877A
SW1 (Fast/Slow)	Don't care
SW2 (RC/Xtal)	Xtal
Xtal frequency	19.6608MHz
Port A	
Port B	LCD board EB005
Port C	RFID board EB052
Port D	
Port E	
Test program	RFID.hex

Ensure that the Multiprogrammer is in correct configuration

- Fast mode (SW1 towards the center of the board)
- XTAL mode (SW2 towards the center of the board)

Ensure that a 19.6608MHz crystal is inserted in the Multiprogrammer board

Wire a connection between the +V on the Mutiprogrammer and the +V on the EB052 RFID E-Block.

Wire a connection between the +V on the Multiprogrammer and the +V on the EB005 LCD E-Block.

Power up the Multiprogrammer using the external 14V power supply.

Make sure jumpers are set to 'C' and '2' on the RFID board.

Download the test program, RFID.hex to the PIC16F877A on the Multiprogrammer.

2. Test Procedure

1. Place a 13.56MHz ICODE RFID Tag on top of the PCB antenna.
2. If the green LED lights up then the RFID module can communicate with the tag correctly.
3. If the red LED stays lit then the RFID module cannot see the tag.
4. Keeping the RFID module in place, press reset on the Multiprogrammer
5. LCD will print "Test Starting"
6. If communication was successful then the LCD will print "Comms Passed"
7. Otherwise the LCD will display "Comms Failed"

5. Circuit description

1. Description

The circuit board consists of 3 digital I/O lines on a 'downstream' 9-way D-type plug. The patch system acts to route the transmit (TX), receive (RX) and clear to send (CTS) lines to the RFID module in a number of different configurations. The RFID module supplied with the board is a 13.56MHz device however this can be replaced by the 125KHz module that is available separately. The module's antenna is routed to the correct endpoint via jumper J1. In the 13.56MHz mode the onboard PCB antenna must be connected to the RFID module, tuning capacitor C5 is used to tune the module to the antenna. When using the 125KHz module the jumper J1 must be in the 125KHz position which routes the antenna signals to the external antenna screw terminals (Not fitted as standard). The LEDs on the board show the status of the RFID module, a flashing red LED means that the module's antenna needs tuning using C5. A solid red LED means that the antenna is tuned but no RFID devices are present and a green LED indicates that an RFID device is present and connected.

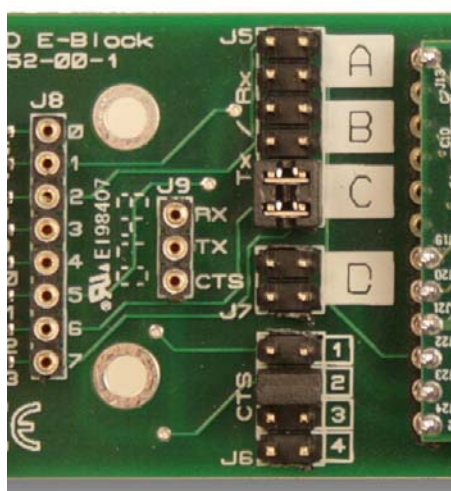

Example configuration for the PIC16F877A

Jumper Setting A	Jumper Setting B	Jumper Setting C		Jumper Setting D
		PIC 16F Devices	PIC 16C Devices	
PIC16F87	PIC16F627/A	PIC16F73	PIC16C63	PATCH SYSTEM
PIC16F88	PIC16F628/B	PIC16F737	PIC16CR63	
	PIC16F648A	PIC16F74	PIC16C65/A/B	
		PIC16F746	PIC16RC65	
		PIC16F76	PIC16C66	
		PIC16F767	PIC16C73/A/B	
		PIC16F77	PIC16C74/A/B	
		PIC16F777	PIC16C745	
		PIC16870/1	PIC16C765	
		PIC16F873/A	PIC16C77	
		PIC16F874/A	PIC16C773	
		PIC16F876/A	PIC16C774	
		PIC16F877/A		

The following table shows the settings that can be used for CTS (clear to send) data output bit.

Jumper Setting 1	Jumper Setting 2	Jumper Setting 3	Jumper Setting 4
0	4	N/C	PATCH SYSTEM

2. Antenna Configuration

a. Internal 13.56MHz

The internal 13.56MHz antenna is selected by moving the jumpers on J1 to the 13.56MHz setting. The internal antenna can be tuned by adjusting the trimming capacitor C5 with a small flat head screwdriver. The tuning for the internal antenna is correct when the Red LED stays permanently lit.

b. External 125KHz

The external 125KHz antenna is selected by moving the jumpers on J1 to the 125KHz setting. The external antenna is then connected via the screw terminals J2 (not fitted as standard). The 125KHz RFID module and 125KHz external antenna are available separately.

Appendix 1 – Circuit diagram

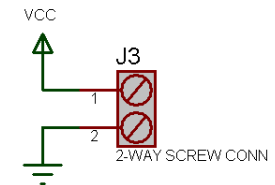
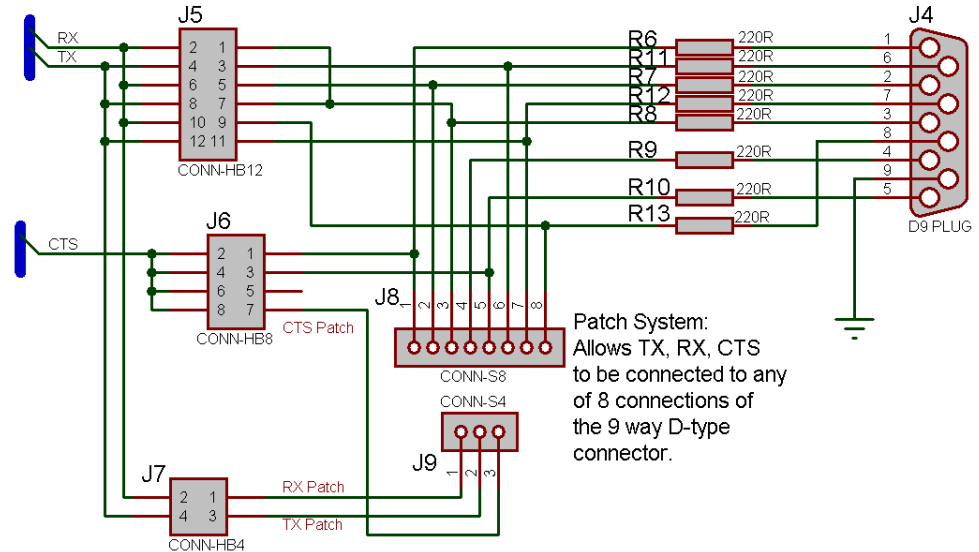
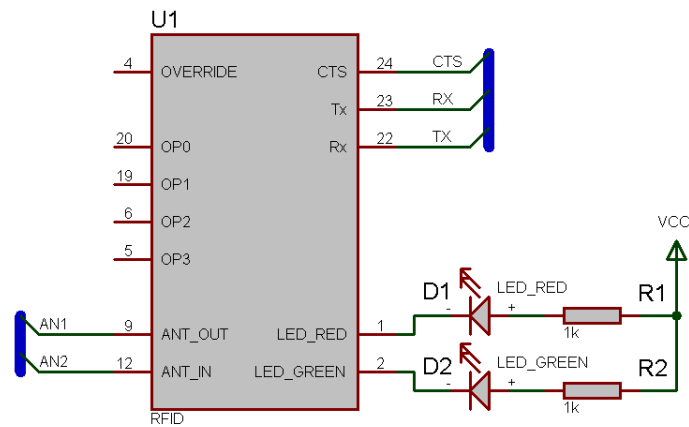
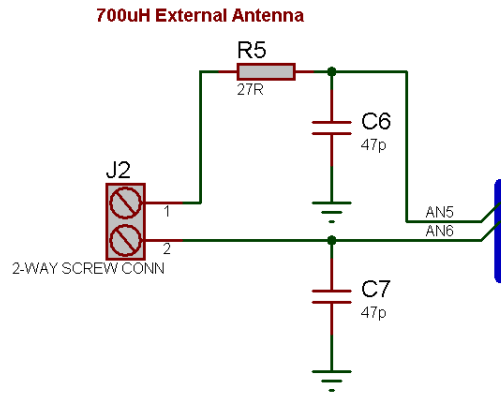
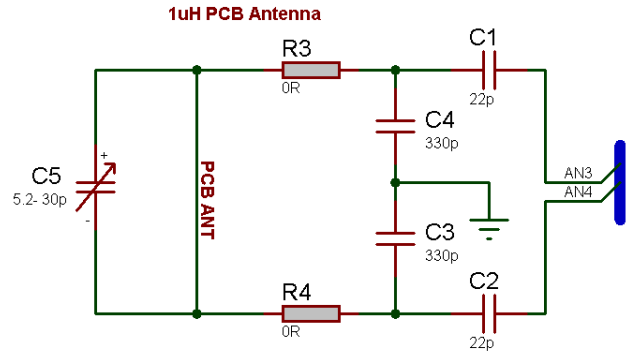

RFID Frequency Control

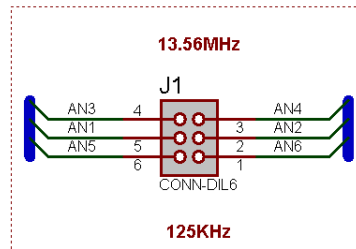

TITLE:	DATE:
E-Blocks RFID Board	16/07/07
EB052-00-1	PAGE:
BY: Ben Rowland	1/1
REV: 1	