

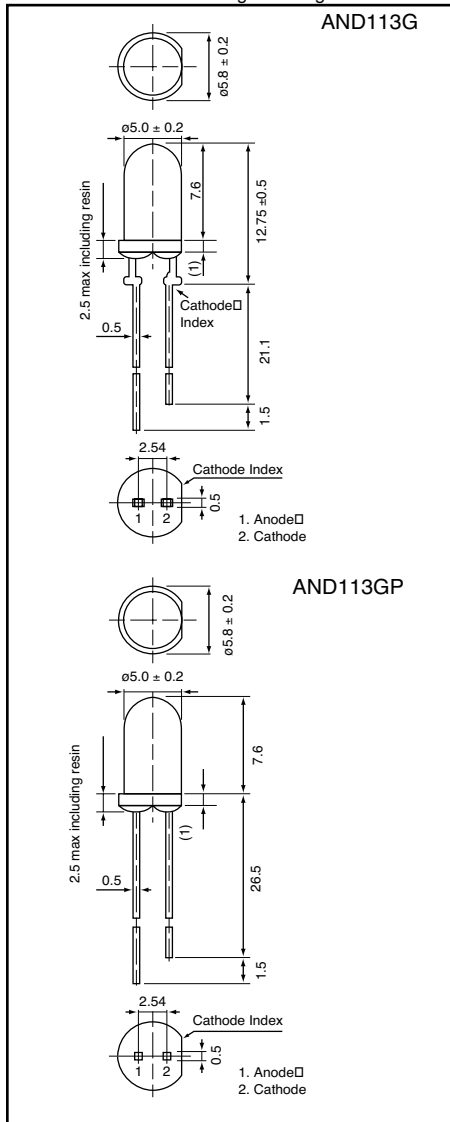

AND113G/GP Standard LED

Standard Bright LED LAMPS

Weight: 0.30 g Unit: mm



Product specifications contained herein may be changed without prior notice. It is therefore advisable to contact Purdy Electronics before proceeding with the design of equipment incorporating this product.

AND113G/GP

Standard LED

T-1 3/4 Package (5 mm)

Features

- Low power requirement
- Flush-mount
- All plastic molded lens
- Color: GaP-Green

• RoHS Compliant

Optical Characteristics ($T_a = 25^\circ\text{C}$)

Color		Lens Desc.	Axial Luminous Intensity (mcd)		Test Condition (I_F -mA)	Viewing Angle $2\theta_{1/2}$ (deg)
LED	Lens		Min.	Typ.		
Green	Green	Clear	20	50	10	30

Absolute Maximum Ratings ($T_a = 25^\circ\text{C}$)

Characteristics	Symbol	Rating (Yellow)	Unit
Forward Current (DC)	I_F	25	mA
Reverse Voltage	V_R	5	V
Power Dissipation	P_D	105	mW
Operating Temperature	T_{Opr}	-40 to +85	$^\circ\text{C}$
Storage Temperature Range	T_{Stg}	-40 to +85	$^\circ\text{C}$

Electro-Optical Characteristics ($T_a = 25^\circ\text{C}$)

Characteristics	Symbol	Test Condition	Yellow			Unit
			Min.	Typ.	Max.	
Forward Voltage	V_F	$I_F = 20\text{mA}$	-	2.1	2.5	V
Reverse Current	I_R	$V_R = 5\text{V}$	-	-	10	μA
Peak Emission Wavelength	λ_p	$I_F = 15\text{mA}$	-	565	-	nm
Spectral Line Half Width	λ	$I_F = 15\text{mA}$	-	30	-	nm

Precaution

Please be careful of the following:

1. Soldering temperature: 260°C max; Soldering time: 5 sec. max; Soldering portion of lead: up to 1.6 mm from the body of the device.
2. The lead can be formed up to 5 mm from the body of the device without forming stress. Soldering should be performed after the lead forming.



AND113G/GP Standard LED

Standard Bright LED LAMPS

