

Toggle Switches



Specifications:

Electrical:

Maximum contact rating	: Silver : 5 A at 120 V ac or 28 V dc, 2 A at 250 V ac, F*
	: Gold : 0.4 VA at 20 V (ac or dc), G*
Maximum contact resistance	: 10 mΩ
Minimum insulation resistance	: 1,000 MΩ at 500 V dc
Dielectric strength	: 1,000 V rms

Mechanical:

Life	: 40,000 cycles
------	-----------------

Environmental:

Operating temperature	: -30°C to +85°C
-----------------------	------------------

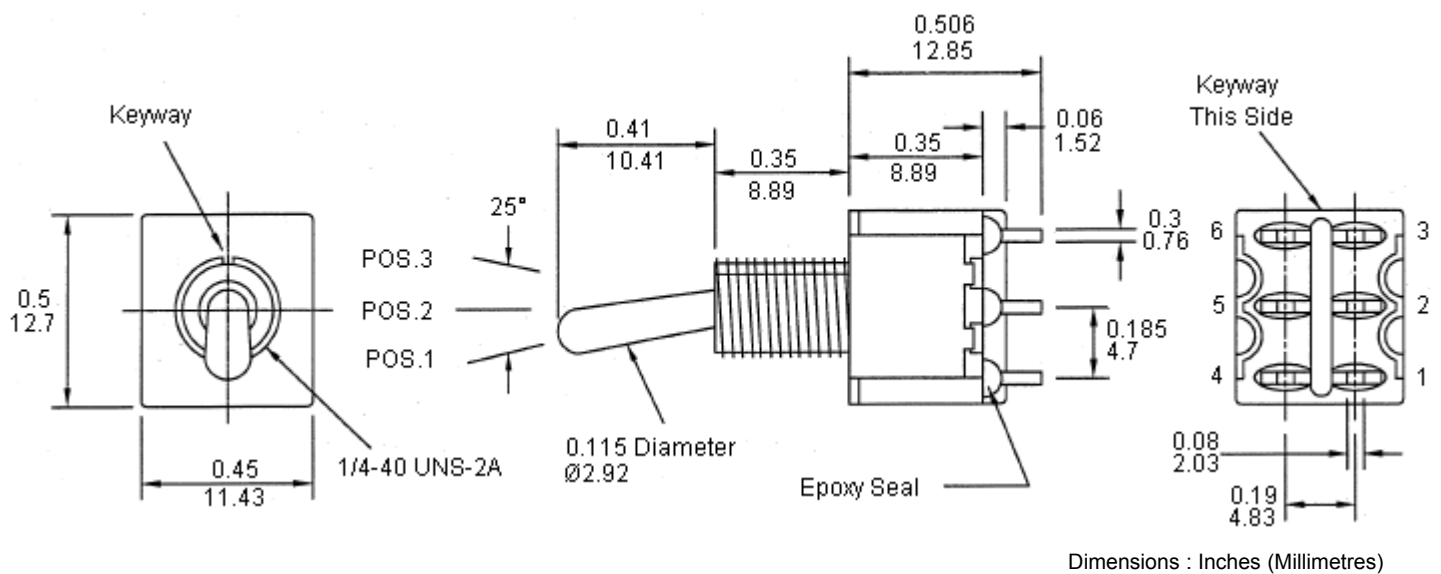

Material:

Case	: DAP
Housing	: Stainless steel
Actuator	: Brass, chrome plated
Bushing	: Brass, nickel plated
Support	: Brass, tin plated
Contact / Terminals	: Copper alloy, silver or gold plated



Toggle Switches

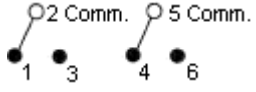

Model No.	Switching Position		
			
A*	ON	NONE	ON
B*	ON	NONE	MOM
C*	ON	OFF	ON
D*	MOM	OFF	MOM
E*	ON	OFF	MOM
Conn. Terms	2-3 5-6	OPEN	2-1 5-4
Schematic	DPDT 		

For PC Mount Termination Only

PCB Layout
Component Side

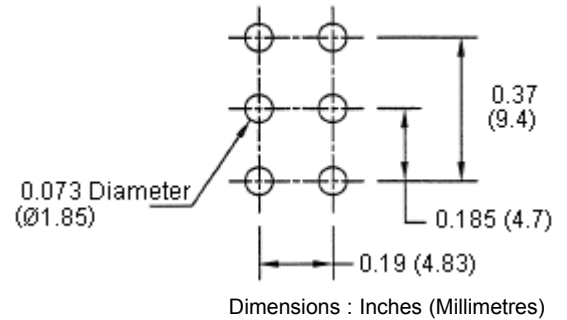

Actuator Options

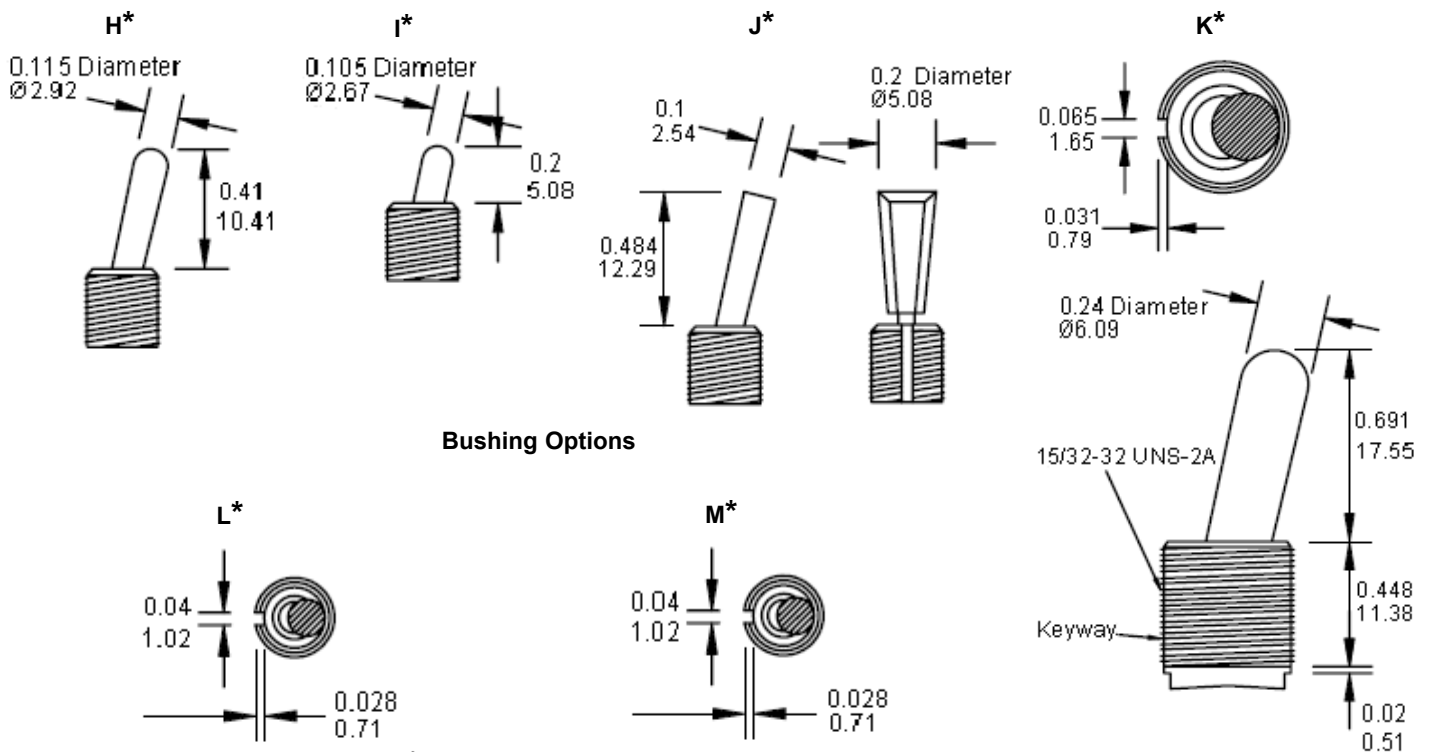

Bushing Options

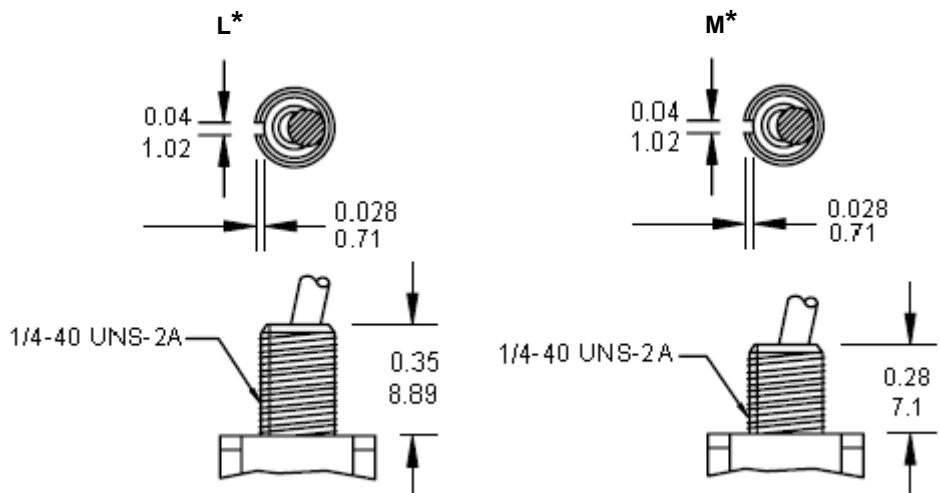

Dimensions : Inches (Millimetres)

Toggle Switches



Bushing Options

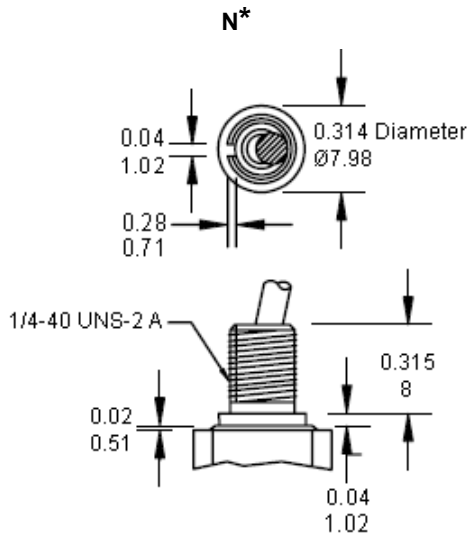

Termination Options

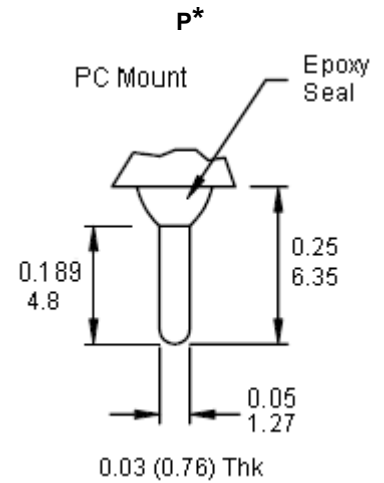
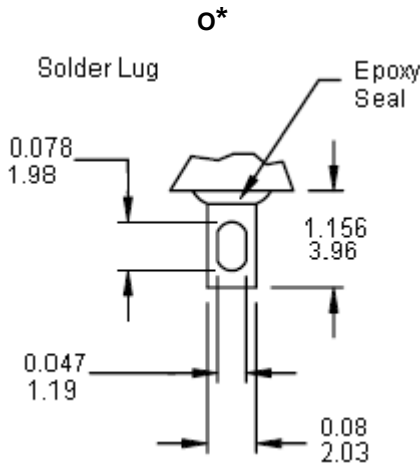

Dimensions : Inches (Millimetres)

Vertical Support Bracket

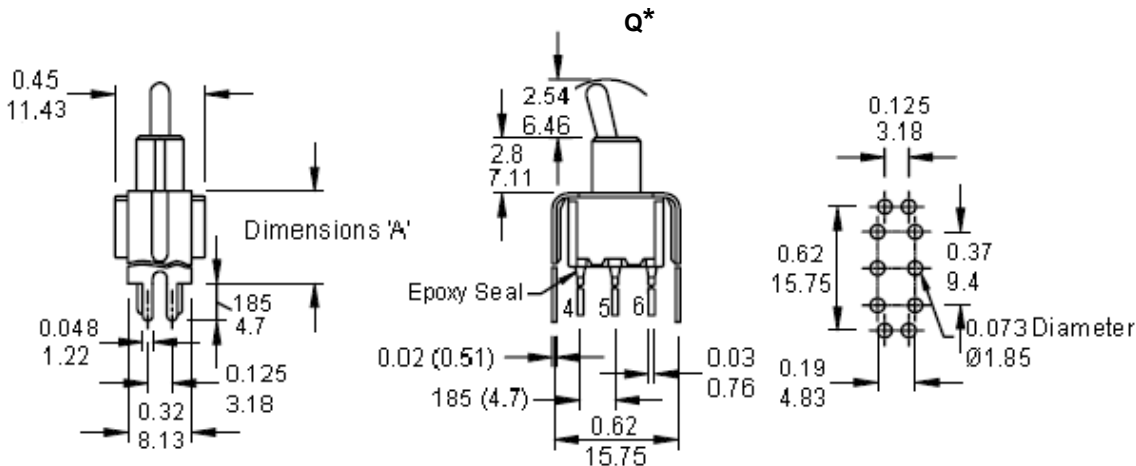

Dimensions : Inches (Millimetres)

Dimension Table

	'A'
S30	0.63 (16)

Standard Nut

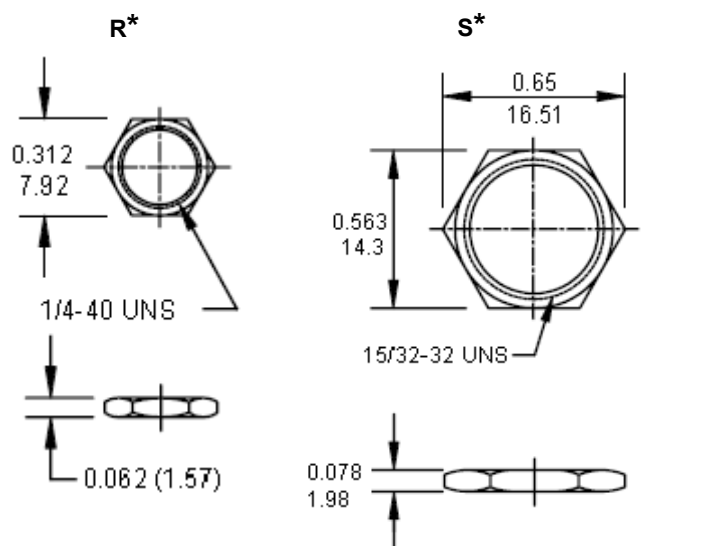

Dimensions : Inches (Millimetres)

Toggle Switches

Lock Washer

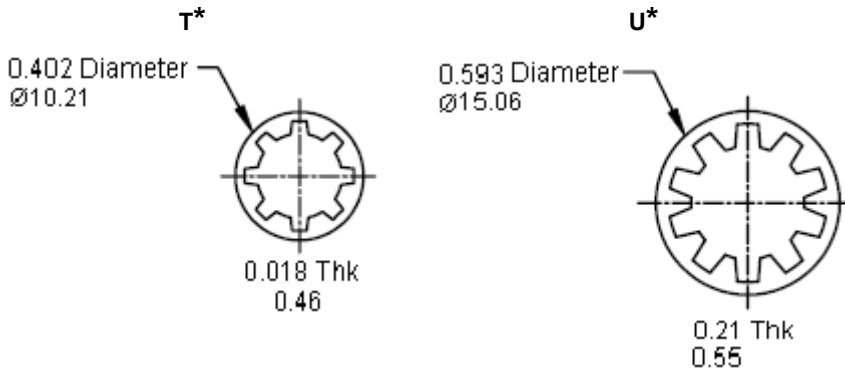

Locking Ring

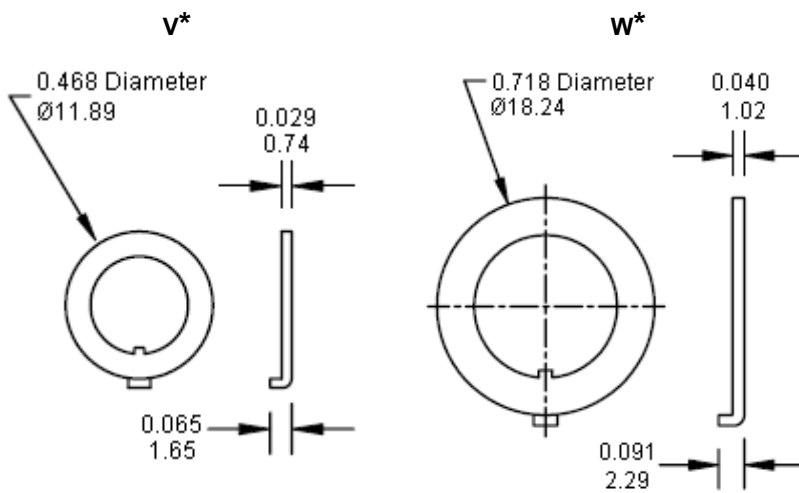

Panel Mounting

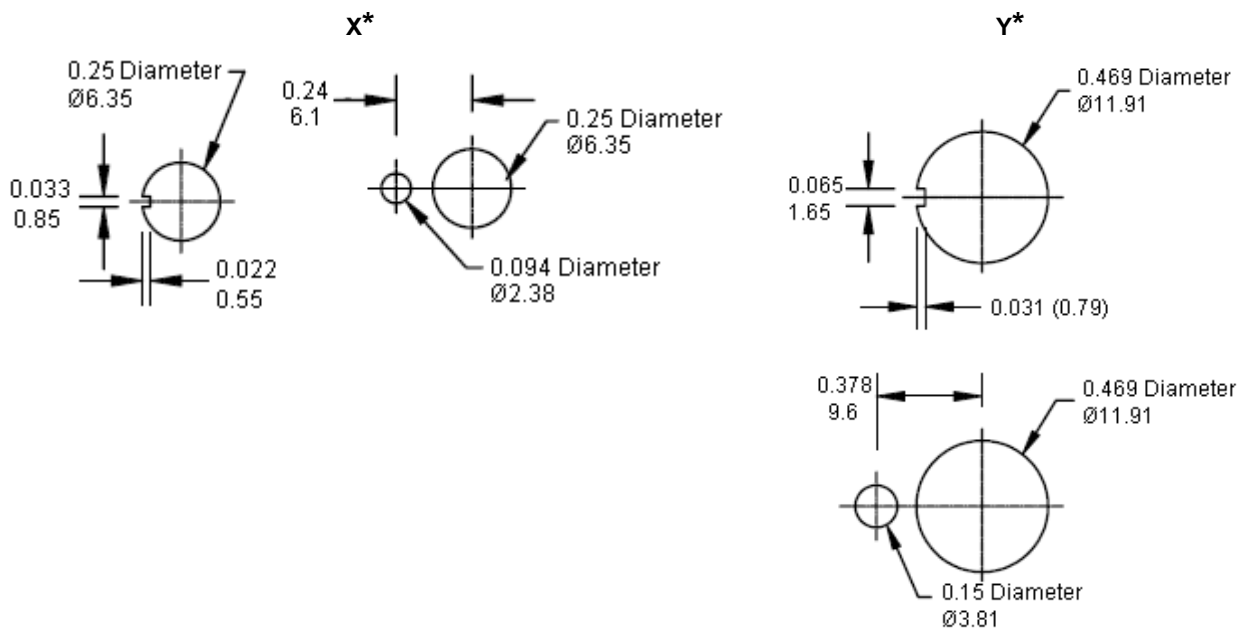

Dimensions : Inches (Millimetres)

Toggle Switches



Part Number Table

Description	Part Number	
Toggle Switch	SPC21412	A*, F*, H*, N*, O*, R*, V*, X*
Toggle Switch	SPC21284	A*, F*, H*, L*, O*, R*, T*, V*, X*
Toggle Switch	SPC21285	B*, F*, H*, L*, O*, R*, T*, V*, X*
Toggle Switch	SPC21286	F*, C*, H*, L*, O*, R*, T*, V*, X*
Toggle Switch	SPC21287	D*, F*, H*, L*, O*, R*, T*, V*, X*
Toggle Switch	SPC21288	E*, F*, H*, L*, O*, R*, T*, V*, X*
Toggle Switch	SPC21289	A*, F*, H*, L*, P*, R*, T*, V*, X*
Toggle Switch	SPC21290	A*, G*, H*, L*, P*, R*, T*, V*, X*
Toggle Switch	SPC21291	B*, F*, H*, L*, P*, R*, T*, V*, X*
Toggle Switch	SPC21292	B*, G*, H*, L*, P*, R*, T*, V*, X*
Toggle Switch	SPC21293	C*, F*, H*, L*, P*, R*, T*, V*, X*
Toggle Switch	SPC21294	C*, G*, H*, L*, P*, R*, T*, V*, X*
Toggle Switch	SPC21295	D*, F*, H*, L*, P*, R*, T*, V*, X*
Toggle Switch	SPC21296	D*, G*, H*, L*, P*, R*, T*, V*, X*
Toggle Switch	SPC21297	E*, F*, H*, L*, P*, R*, T*, V*, X*
Toggle Switch	SPC21298	E*, G*, H*, L*, P*, R*, T*, V*, X*
Toggle Switch	SPC21299	A*, F*, J*, L*, O*, R*, T*, V*, X*
Toggle Switch	SPC21300	B*, F*, J*, L*, O*, R*, T*, V*, X*
Toggle Switch	SPC21301	C*, F*, J*, L*, O*, R*, T*, V*, X*
Toggle Switch	SPC21302	D*, F*, J*, L*, O*, R*, T*, V*, X*
Toggle Switch	SPC21303	E*, F*, J*, L*, O*, R*, T*, V*, X*
Toggle Switch	SPC21304	A*, F*, K*, O*, S*, U*, W*, Y*
Toggle Switch	SPC21305	B*, F*, K*, O*, S*, U*, W*, Y*
Toggle Switch	SPC21306	C*, F*, K*, O*, S*, U*, W*, Y*
Toggle Switch	SPC21307	D*, F*, K*, O*, S*, U*, W*, Y*
Toggle Switch	SPC21308	E*, F*, K*, O*, S*, U*, W*, Y*
Toggle Switch	SPC21309	A*, G*, I*, M*, P*, Q*, X*
Toggle Switch	SPC21310	B*, G*, I*, M*, P*, Q*, X*
Toggle Switch	SPC21311	C*, G*, I*, M*, P*, Q*, X*
Toggle Switch	SPC21312	D*, G*, I*, M*, P*, Q*, X*
Toggle Switch	SPC21313	E*, G*, I*, M*, P*, Q*, X*

Disclaimer This data sheet and its contents (the "Information") belong to the Premier Farnell Group (the "Group") or are licensed to it. No licence is granted for the use of it other than for information purposes in connection with the products to which it relates. No licence of any intellectual property rights is granted. The Information is subject to change without notice and replaces all data sheets previously supplied. The Information supplied is believed to be accurate but the Group assumes no responsibility for its accuracy or completeness, any error in or omission from it or for any use made of it. Users of this data sheet should check for themselves the Information and the suitability of the products for their purpose and not make any assumptions based on information included or omitted. Liability for loss or damage resulting from any reliance on the Information or use of it (including liability resulting from negligence or where the Group was aware of the possibility of such loss or damage arising) is excluded. This will not operate to limit or restrict the Group's liability for death or personal injury resulting from its negligence. SPC Multicomp is the registered trademark of the Group. © Premier Farnell plc 2011.

<http://www.farnell.com>
<http://www.newark.com>
<http://www.cpc.co.uk>

