



### Main

Range of product	Phase0
Product or component type	Redundancy module
Input voltage	24...28.8 V DC
Output voltage	(U <sub>in</sub> -0.2) V DC
Maximum output current	40 A

### Complementary

Input voltage limits	22...30 V
Input current	20 A
Number of output channels	1
Output protection type	Against overload, protection technology: external protection by power supply Against short-circuits, protection technology: external protection by power supply
Connections - terminals	Removable screw terminal block for diagnostic relay, connection capacity: 1 x 2.5 mm <sup>2</sup> AWG gauge14 Screw type terminals for input connection, connection capacity: 4 x 0.5...4 x 10 mm <sup>2</sup> AWG gauge20...8 Screw type terminals for output connection, connection capacity: 2 x 0.5...2 x 10 mm <sup>2</sup> AWG gauge20...8
Fixing mode	By clips on 35 mm symmetrical DIN rail, operating position: horizontal By clips on 35 mm symmetrical DIN rail, operating position: vertical
Output coupling	Parallel
Marking	CE
Name of test	Conducted/Radiated emissions conforming to EN 55022 Class B Electrostatic discharges conforming to EN/IEC 61000-4-2 Emission conforming to EN 50081-1 Emission conforming to EN 61000-6-3 Induced electromagnetic field conforming to EN/IEC 61000-4-6 level 3 Radiated electromagnetic field conforming to EN/IEC 61000-4-3 level 3 Rapid transient conforming to IEC 61000-4-4 level 3 Surge conforming to EN/IEC 61000-4-5 level 2
Local signalling	1 LED per input green, function: power supply status 1 relay , function: power supply status
Product weight	0.7 kg

### Environment

IP degree of protection	IP10 conforming to EN/IEC 60529
Ambient air temperature for operation	-25...60 °C
Ambient air temperature for storage	-40...85 °C
Relative humidity	0...90 % during operation 0...95 % during storage
Class of protection against electric shock	Class II conforming to VDE 0106-1
Vibration resistance	2 gn (f = 11.9...150 Hz) conforming to EN/IEC 61131-2 3.5 mm (f = 3...11.9 Hz) conforming to EN/IEC 61131-2
Dielectric strength	500 V between input and ground 500 V between output and ground
Product certifications	CCSAus C-Tick UL

Environmental characteristic	EMC conforming to EN 61000-6-3 EMC conforming to EN/IEC 61000-6-2 Safety conforming to EN/IEC 60950-1 Safety conforming to EN/IEC 61204
RoHS EUR status	Compliant
RoHS EUR conformity date	0501

Redundancy Module

Dimensions

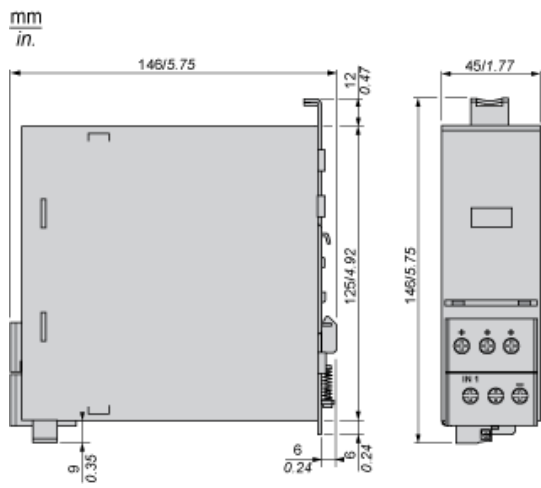

---

Redundancy Module

---

Mounting

Redundancy modules can be installed on a DIN rail. The graphic below provides the characteristics and references of the compatible DIN rails for the mounting of the module.

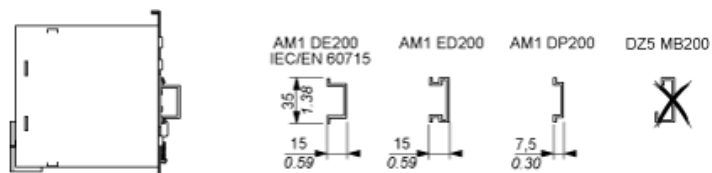

Wiring Requirements

Cable Types and Wire Sizes

	ABL	8RPS24030	8RPS24050 8RPS24100	8RPM24200 8WPS24200/24400
+ In -	mm <sup>2</sup> /AWG	1...4 / 16...12		
+ Out -	mm <sup>2</sup> /AWG	1...4 / 16...12	4...10 / 12...6	
	mm/In	4 / 0.16		
11...14	mm <sup>2</sup> /AWG	-	0,2...2,5 / 24...14	

Internal Wiring Diagram

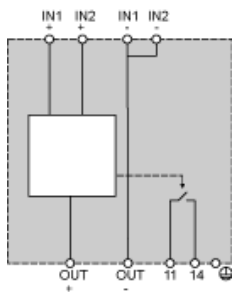

Scheme of Use with Power Supplies

Wiring Diagram with  $I_n \leq 20\text{mA}$

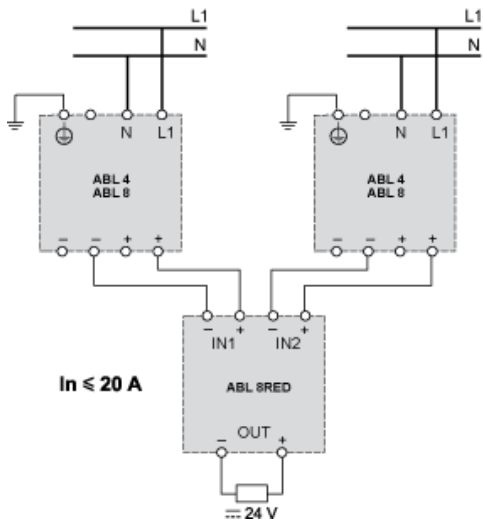

# Wiring Diagram with $I_n \leq 40\text{mA}$

