

**Circuits from the Lab™**  
Reference Circuits

Circuits from the Lab™ reference circuits are engineered and tested for quick and easy system integration to help solve today's analog, mixed-signal, and RF design challenges. For more information and/or support, visit [www.analog.com/CN0217](http://www.analog.com/CN0217).

### Devices Connected/Referenced

AD5933	1 MSPS, 12-Bit Impedance Converter, Network Analyzer
AD5934	250kSPS, 12-Bit Impedance Converter, Network Analyzer
AD8606	Precision Low Noise Dual CMOS Op Amp

## High Accuracy Impedance Measurements Using 12-Bit Impedance Converters

### EVALUATION AND DESIGN SUPPORT

#### Circuit Evaluation Boards

CN-0217 Circuit Evaluation Board  
(EVAL-CN0217-EB1Z)

#### Design and Integration Files

[Schematics](#), [Layout Files](#), [Bill of Materials](#)

### CIRCUIT FUNCTION AND BENEFITS

The AD5933 and AD5934 are high precision impedance converter system solutions that combine an on-chip programmable frequency generator with a 12-bit, 1 MSPS (AD5933) or 250 kSPS (AD5934) analog-to-digital converter (ADC). The tunable frequency generator allows an external complex impedance to be excited with a known frequency.

The circuit shown in Figure 1 yields accurate impedance measurements extending from the low ohm range to several hundred kΩ and also optimizes the overall accuracy of the AD5933/AD5934.

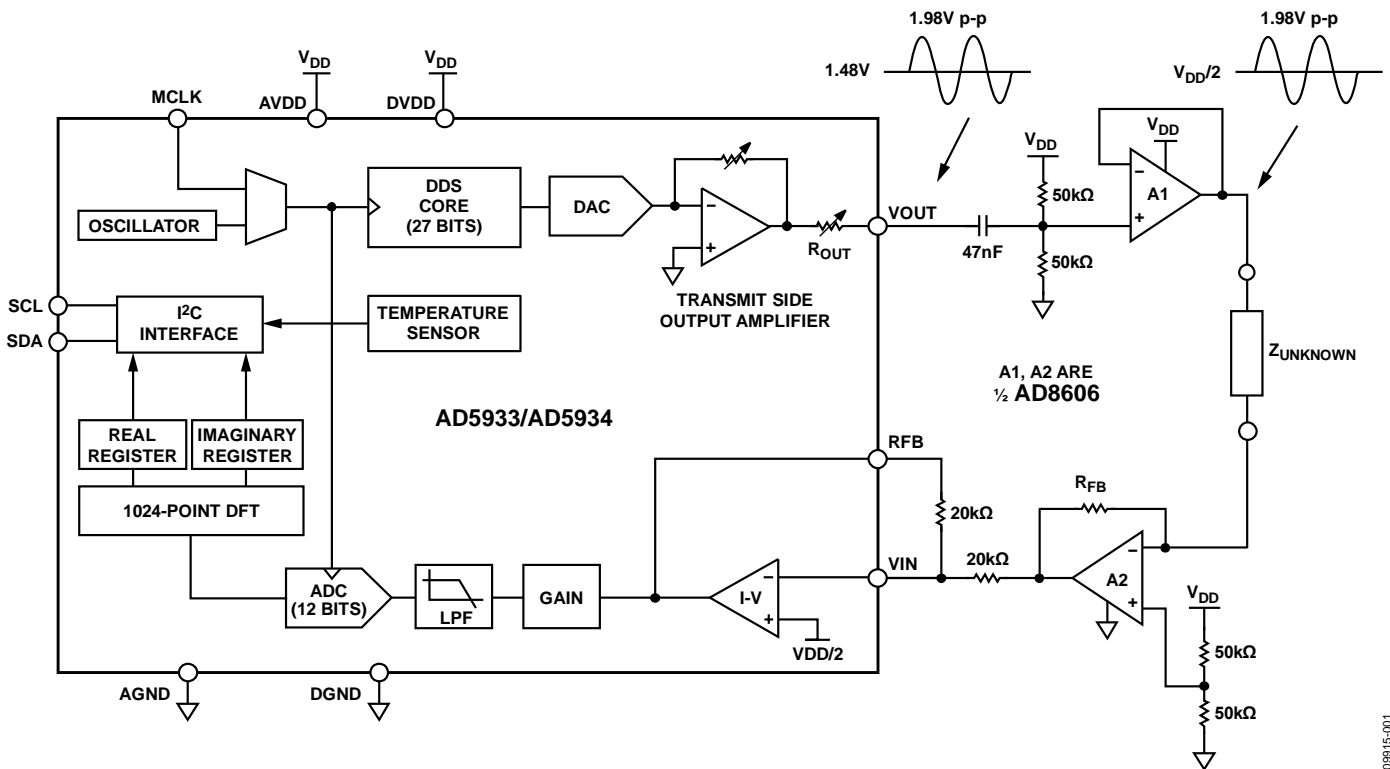

Figure 1. Optimized Signal Chain for Impedance Measurement Accuracy (Simplified Schematic, All Connections and Decoupling Not Shown)

#### Rev.0

Circuits from the Lab™ circuits from Analog Devices have been designed and built by Analog Devices engineers. Standard engineering practices have been employed in the design and construction of each circuit, and their function and performance have been tested and verified in a lab environment at room temperature. However, you are solely responsible for testing the circuit and determining its suitability and applicability for your use and application. Accordingly, in no event shall Analog Devices be liable for direct, indirect, special, incidental, consequential or punitive damages due to any cause whatsoever connected to the use of any Circuits from the Lab circuits. (Continued on last page)

## CIRCUIT DESCRIPTION

The [AD5933](#) and [AD5934](#) have four programmable output voltage ranges; each range has an output impedance associated with it. For example, the output impedance for a 1.98 V p-p output voltage is typically 200  $\Omega$  (see Table 1).

**Table 1. Output Series Resistance,  $R_{OUT}$ , vs. Excitation Range for  $V_{DD} = 3.3$  V Supply Voltage,**

Range	Output Excitation Amplitude	Output Resistance, $R_{OUT}$
Range 1	1.98 V p-p	200 $\Omega$ typ
Range 2	0.97 V p-p	2.4 k $\Omega$ typ
Range 3	0.383 V p-p	1.0 k $\Omega$ typ
Range 4	0.198 V p-p	600 $\Omega$ typ

This output impedance impacts the impedance measurement accuracy, particularly in the low k $\Omega$  range, and should be taken into account when calculating the gain factor. Please refer to the [AD5933](#) or [AD5934](#) data sheets for more details on gain factor calculation.

A simple buffer in the signal chain prevents the output impedance from affecting the unknown impedance measurement. A low output impedance amplifier should be selected with sufficient bandwidth to accommodate the [AD5933/AD5934](#) excitation frequency. An example of the low output impedance achievable is shown in Figure 2 for the [AD8605/AD8606/AD8608](#) family of CMOS op amps. The output impedance for this amplifier for an  $A_V$  of 1 is less than 1  $\Omega$  up to 100 kHz, which is the maximum operating range of the [AD5933/AD5934](#).

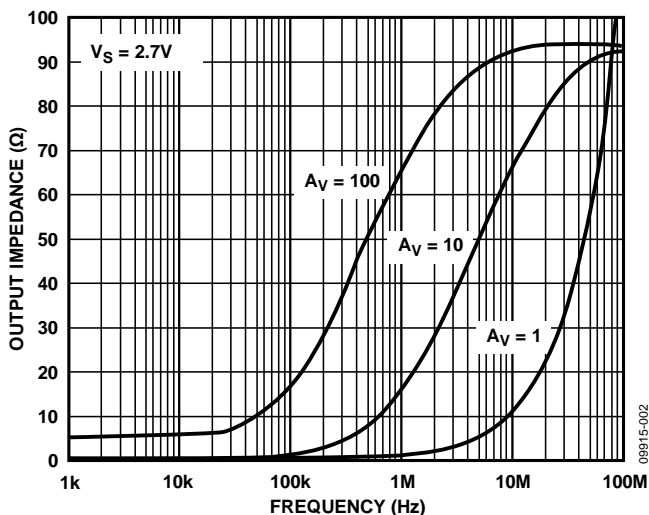

Figure 2. Output Impedance of [AD8605/AD8606/AD8608](#)

## Matching the DC Bias of Transmit Stage to Receive Stage

The four programmable output voltage ranges in the [AD5933/AD5934](#) have four associated bias voltages (Table 2). For example, the 1.98 V p-p excitation voltage has a bias of 1.48 V. However, the current-to-voltage (I-V) receive stage of the [AD5933/AD5934](#) is set to a fixed bias of  $V_{DD}/2$  as shown in Figure 1. Thus, for a 3.3 V supply, the transmit bias voltage is 1.48 V, while the receive bias voltage is  $3.3 \text{ V}/2 = 1.65 \text{ V}$ . This potential difference polarizes the impedance under test and can cause inaccuracies in the impedance measurement.

One solution is to add a simple high-pass filter with a corner frequency in the low Hz range. Removing the dc bias from the transmit stage and re-biasing the ac signal to  $V_{DD}/2$  keeps the dc level constant throughout the signal chain.

**Table 2. Output Levels and Respective DC Bias for  $V_{DD} = 3.3$  V Supply Voltage**

Range	Output Excitation Amplitude	Output DC Bias Level
1	1.98 V p-p	1.48 V
2	0.97 V p-p	0.76 V
3	0.383 V p-p	0.31 V
4	0.198 V p-p	0.173 V

## Selecting an Optimized I-V Buffer for the Receive Stage

The current-to-voltage (I-V) amplifier stage of the [AD5933/AD5934](#) can also add minor inaccuracies to the signal chain. The I-V conversion stage is sensitive to the amplifier's bias current, offset voltage, and CMRR. By selecting the proper external discrete amplifier to perform the I-V conversion, the user can choose an amplifier with lower bias current and offset voltage specifications along with excellent CMRR, making the I-V conversion more accurate. The internal amplifier can then be configured as a simple inverting gain stage.

Selection of resistor  $R_{FB}$  still depends on the gain through the system as described in the [AD5933/AD5934](#) data sheet.

## Optimized Signal Chain for High Accuracy Impedance Measurements

Figure 1 shows a proposed configuration for measuring low impedance sensors. The ac signal is high-pass filtered and re-biased before buffering with a very low output impedance amplifier. The I-V conversion is completed externally before the signal returns to the [AD5933/AD5934](#) receive stage. Key specifications that determine the required buffer are very low output impedance, single-supply capability, low bias current, low offset voltage, and excellent CMRR performance. Some suggested parts are the [AD4528-1](#), [AD8628/AD8629](#), [AD8605](#), and [AD8606](#). Depending on board layout, use a single-channel or dual-channel amplifier. Use precision 0.1% resistors for both the biasing resistors (50 k $\Omega$ ) and gain resistors (20 k $\Omega$  and  $R_{FB}$ ) to reduce inaccuracies.

## CIRCUIT EVALUATION AND TEST

The schematic in Figure 1 was developed to improve impedance measurement accuracy, and some example measurements were taken. The AD8606 dual channel amplifier buffers the signal on the transmit path and converts the receive signal from current to voltage. For the three examples shown, the gain factor is calculated for each frequency increment to remove frequency dependent errors. A complete design package including schematics, bill of materials, layout, and Gerber files is available for this solution at <http://www.analog.com/CN0217-DesignSupport>. The software used is the same software that is available with evaluation boards and is accessible from the AD5933 and AD5934 product pages.

### Example 1: Low Impedance Range

**Table 1. Low Impedance Range Setup for VDD = 3.3 V Supply Voltage**

Parameter	Value
V p-p	1.98 V (Range 1)
Number of Settling Time Cycles	15
MCLK	16 MHz
R <sub>CAL</sub>	20.1 Ω
R <sub>FB</sub>	20.0 Ω
Excitation Frequency Range	30 kHz to 30.2 kHz
Unknown Impedances	R1 = 10.3 Ω, R2 = 30.0 Ω, C3 = 1 μF (Z <sub>c</sub> = 5.3 Ω at 30 kHz)

The results of the low impedance measurements are shown in Figure 3, Figure 4, and Figure 5. Figure 5 is for the 10.3 Ω measurement and is shown on an expanded vertical scale.

The accuracy achieved is very much dependent on how large the unknown impedance range is relative to the calibration resistor, R<sub>CAL</sub>. Therefore, in this example, the unknown impedance of 10.3 Ω measured 10.13 Ω, an approximate 2% error. Choosing an R<sub>CAL</sub> closer to the unknown impedance achieves a more accurate measurement; that is, the smaller the unknown impedance range is centered around R<sub>CAL</sub> is, the more accurate the measurement. Consequently, for large unknown impedance ranges, it is possible to switch in various R<sub>CAL</sub> resistors to break up the unknown impedance range using external switches. The R<sub>ON</sub> error of the switch is removed by calibration during the R<sub>CAL</sub> gain factor calculation. Using a switch to select various R<sub>FB</sub> values can optimize the dynamic range of the signal seen by the ADC.

Also note that to achieve a wider range of measurements a 200 mV p-p range was used. If the unknown Z is a small range, a larger output voltage range can be used to optimize the ADC dynamic range.

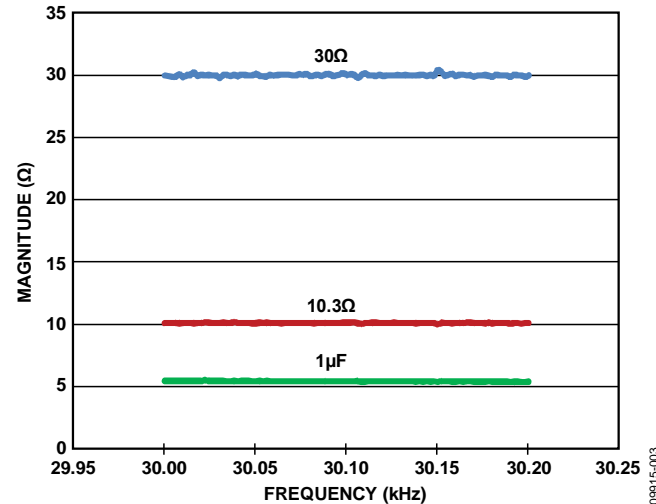

Figure 3. Measured Low Impedance Magnitude Results

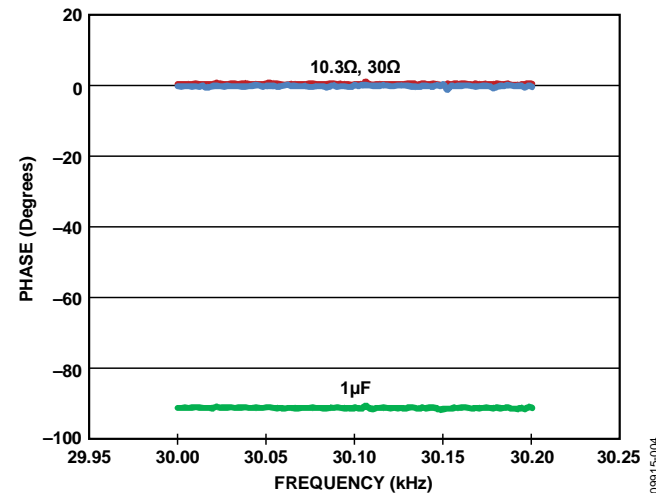

Figure 4. Measured Low Impedance Phase Results

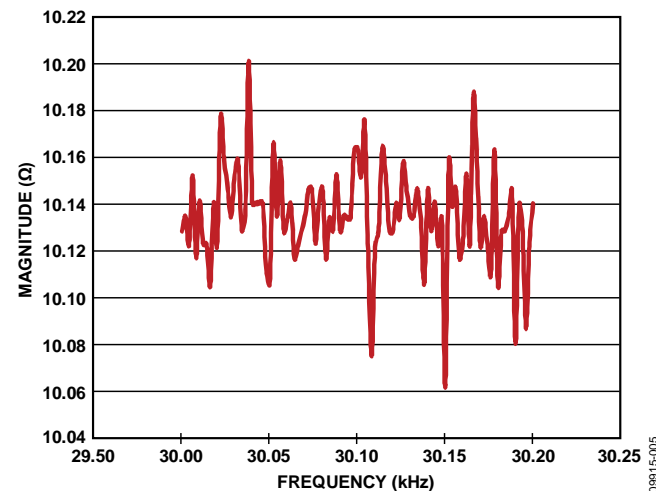

Figure 5. Measured 10.3 Ω Magnitude Results (Expanded Scale)

**Example 2: kΩ Impedance Range**

Using an  $R_{CAL}$  of 99.85 kΩ, a wide range of unknown impedances were measured according to the setup conditions listed in Table 2. Figure 6 to Figure 10 document accuracy results. To improve the overall accuracy, select an  $R_{CAL}$  value closer to the unknown impedance. For example, in Figure 9, an  $R_{CAL}$  closer to the  $Z_C$  value of 217.5 kΩ is required. If the unknown impedance range is large, use more than one  $R_{CAL}$  resistor.

**Table 2. kΩ Impedance Range Setup for VDD = 3.3 V Supply Voltage**

Parameter	Value
V p-p	0.198 V (Range 4)
Number of Settling Time Cycles	15
MCLK	16 MHz
$R_{CAL}$	99.85 kΩ
$R_{FB}$	100 kΩ
Excitation Frequency Range	30 kHz to 50 kHz
Unknown Impedances	R0 = 99.85 kΩ R1 = 29.88 kΩ R2 = 14.95 kΩ R3 = 8.21 kΩ R4 = 217.25 kΩ C5 = 150 pF ( $Z_C = 26.5$ kΩ at 40 kHz) C6 = 47 pF ( $Z_C = 84.6$ kΩ at 40 kHz)

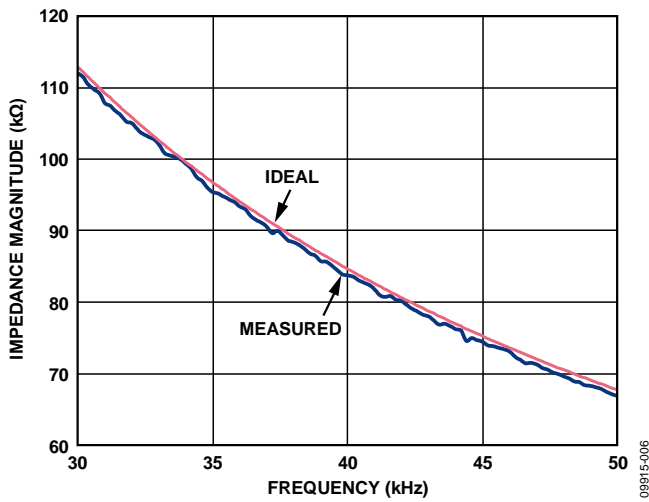

Figure 6. Magnitude Result for  $Z_C = 47$  pF,  $R_{CAL} = 99.85$  kΩ

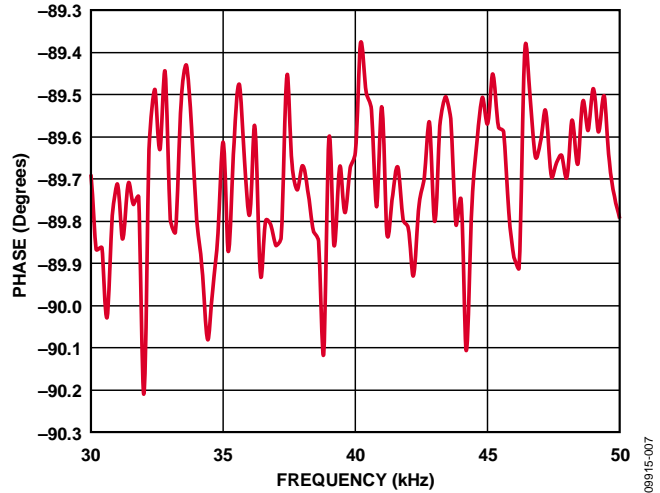

Figure 7. Phase Result for  $Z_C = 47$  pF,  $R_{CAL} = 99.85$  kΩ

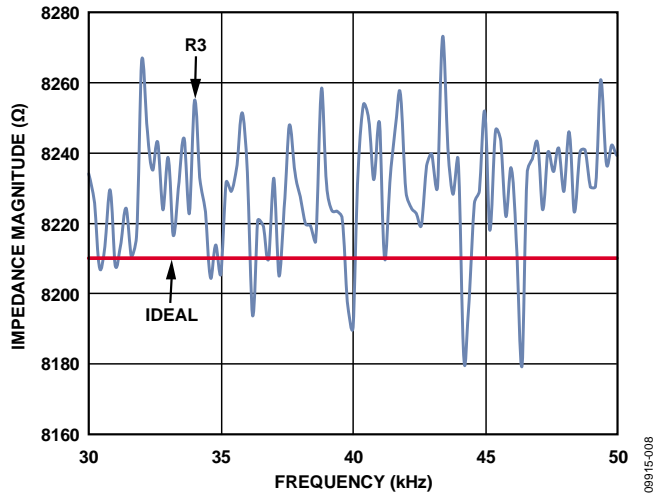

Figure 8.  $Z_C = 8.21$  kΩ,  $R_{CAL} = 99.85$  kΩ

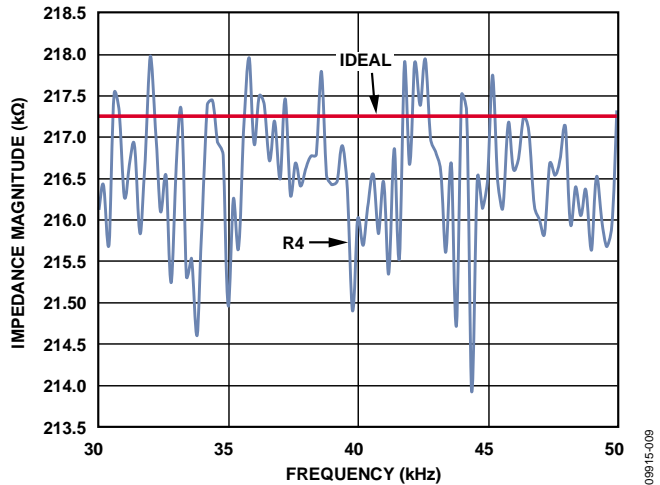

Figure 9.  $Z_C = 217.25$  kΩ,  $R_{CAL} = 99.85$  kΩ

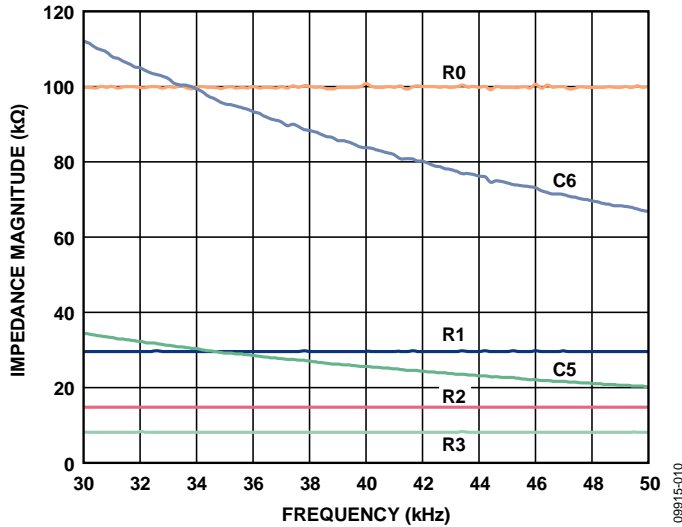

Figure 10. Magnitude Results for Example 2: R1, R2, R3, C5, C6

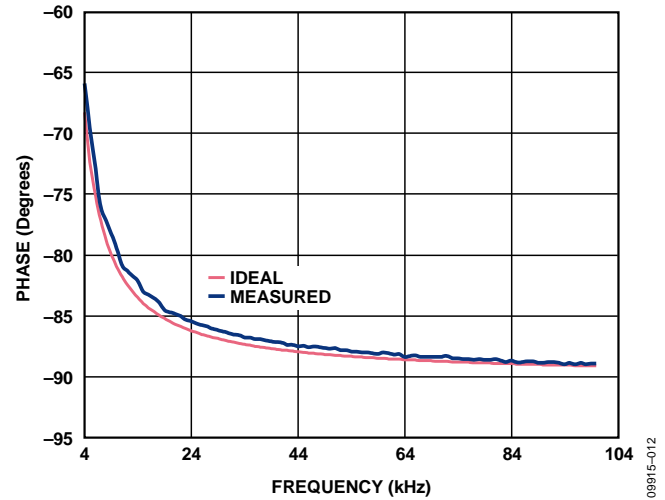

Figure 12. Phase Results for  $Z_C = 10\text{ k}\Omega \parallel 10\text{ nF}$ ,  $R_{CAL} = 1\text{ k}\Omega$

**Example 3: Parallel R-C (R||C) Measurement**

An R||C type measurement was also made using the configuration, using an  $R_{CAL}$  of 1 kΩ, an R of 10 kΩ, and a C of 10 nF, measured across a frequency range of 4 kHz to 100 kHz. The magnitude and phase results versus ideal are plotted in Figure 11 and Figure 12.

**Table 3. R||C Impedance Range Setup for VDD = 3.3 V Supply Voltage**

Parameter	Value
V p-p	0.383 V (Range 3)
Number of Settling Time Cycles	15
MCLK	16 MHz
$R_{CAL}$	1 kΩ
$R_{FB}$	1 kΩ
Excitation Frequency Range	4 kHz to 100 kHz
Unknown Impedance R  C	R = 10 kΩ C = 10 nF

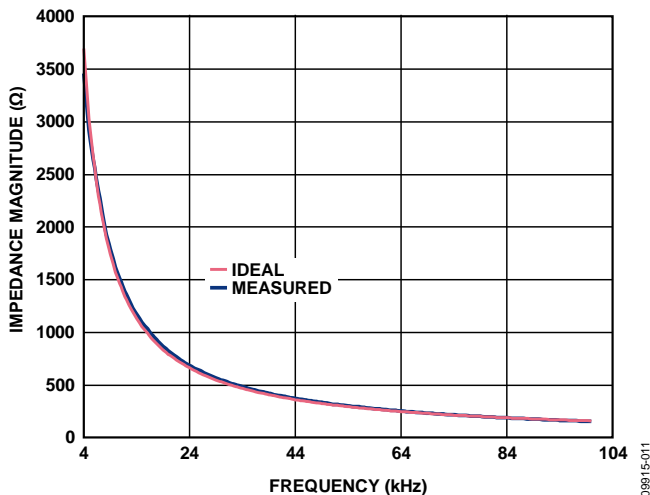

Figure 11. Magnitude Results for  $Z_C = 10\text{ k}\Omega \parallel 10\text{ nF}$ ,  $R_{CAL} = 1\text{ k}\Omega$

**Setup and Test**

The EVAL-CN0217-EB1Z software is the same as that used on the EVAL-AD5933EBZ application board. Please refer to the technical note available on the CD provided for details on the board setup. Note that there are alterations to the schematic. Link connections on the EVAL-CN0217-EB1Z board are listed below in Table 4. Also note that the location for RFB is located at R3 on the evaluation board, and the location for  $Z_{UNKNOWN}$  is C4.

**Table 4. Link Connections for EVAL-CN0217-EB1Z**

Link Number	Default Position
LK1	Open
LK2	Open
LK3	Open
LK4	Insert
LK5	Insert
LK6	A

**COMMON VARIATIONS**

Other op amps can be used in the circuit, such as the [AD4528-1](#), [AD8628](#), [AD8629](#), [AD8605](#), and the [AD8608](#).

**Switching Options for System Applications**

For this particular circuit, the  $Z_{UNKNOWN}$  and  $R_{CAL}$  were interchanged manually. However, in production, a low on-resistance switch should be used. The choice of the switch depends on how large the unknown impedance range is and how accurate the measurement result needs to be. The examples in this document use just one calibration resistor, and so a low on-resistance switch such as the [ADG849](#) can be used as shown in Figure 13. Multichannel switch solutions such as the quad

ADG812 can also be used. The errors caused by the switch resistance on the  $Z_{\text{UNKNOWN}}$  are removed during calibration, but by choosing a very low  $R_{\text{ON}}$  switch, the effects can be further minimized.

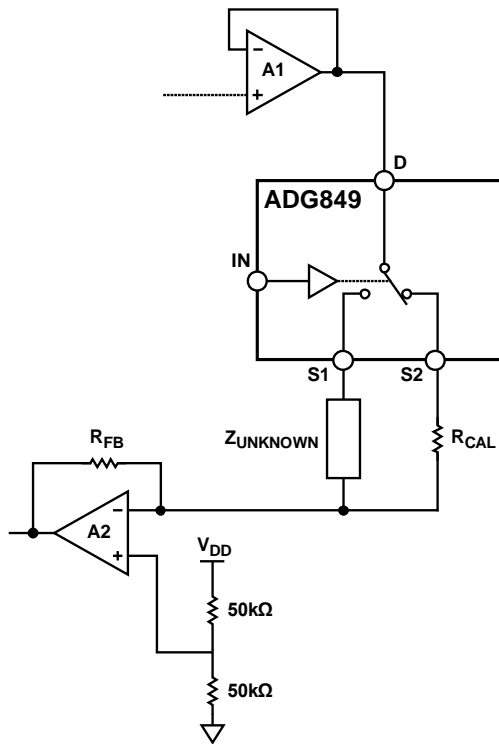

Figure 13. Switching Between  $R_{\text{CAL}}$  and Unknown  $Z$  Using the ADG849 UltraLow  $R_{\text{ON}}$  SPDT Switch (Simplified Schematic, All Connections and Decoupling Not Shown)

## LEARN MORE

CN-0217 Design Support Package:

<http://www.analog.com/CN0217-DesignSupport>

MT-085 Tutorial, "Fundamentals of Direct Digital Synthesis (DDS)," Analog Devices.

Riordan, Liam, "AD5933 Evaluation Board Example Measurement," AN-1053 Application Note, Analog Devices.

Buchanan, David, "Choosing DACs for Direct Digital Synthesis," AN-237 Application Note, Analog Devices.

ADIsimDDS Design and Evaluation Tool

AD5933/AD5934 Demonstration and Design Tool

## Data Sheets and Evaluation Boards

[AD5933 Data Sheet](#)

[AD5933 Evaluation Board](#)

[AD5934 Data Sheet](#)

[AD5934 Evaluation Board](#)

[AD8606 Data Sheet](#)

[ADG849 Data Sheet](#)

[ADG812 Data Sheet](#)

## REVISION HISTORY

6/11—Revision 0: Initial Version

(Continued from first page) Circuits from the Lab circuits are intended only for use with Analog Devices products and are the intellectual property of Analog Devices or its licensors. While you may use the Circuits from the Lab circuits in the design of your product, no other license is granted by implication or otherwise under any patents or other intellectual property by application or use of the Circuits from the Lab circuits. Information furnished by Analog Devices is believed to be accurate and reliable. However, "Circuits from the Lab" are supplied "as is" and without warranties of any kind, express, implied, or statutory including, but not limited to, any implied warranty of merchantability, noninfringement or fitness for a particular purpose and no responsibility is assumed by Analog Devices for their use, nor for any infringements of patents or other rights of third parties that may result from their use. Analog Devices reserves the right to change any Circuits from the Lab circuits at any time without notice but is under no obligation to do so.