



# SSF26 Series

## High temperature internal fitting switch



- Temperature to 200°C
- Stainless steel 316L
- Internal mount via 3/8" BSP
- User configurable N/O (make on rise) or N/C (make on fall)

### Technical Specification

Mounting style	Internal	Cable length - standard	35cm
Mounting thread	3/8" BSP	Cable size	17/0.10 - AWG22
Float & Stem material	316 grade SS	Cable conductor material	Tinned copper
Maximum Temperature	200°C	Cable sheath material	XLPE
Maximum pressure	10 bar	Cable temperature rating	200°C
Float SG	0.55	Sealing gasket	Not supplied
Minimum fluid SG	0.65	Tightening torque for fixing nut	2.0kg/cm

### Electrical Specification

Contact Form		N/O (N/C)
Switching Power Max	VA	50
Switching Voltage AC Max	V	300
Switching Voltage DC Max	V	300
Switching Current Max	A	0.5

All ratings are for resistive load only.

The SSF26 is a vertically mounted float switch designed to give reliable switching at temperatures up to 200°C.

Mounting is in the top or bottom of the tank from the inside, so requires access to the inside of the tank.

These are manufactured in 316 grade stainless steel and will work in liquids of SG 0.65 minimum.

The switch action may be reversed by removing the float, inverting and then refitting it to the stem.

Typical application is in deep frying oil tanks.

### Standard Parts

Standard Parts	Material	Max Power	Leadouts
SSF26X035	SS 316	50VA	50cm XLPE 17/0.1 wires

Custom versions can be made for particular applications. Please contact Cynergy3 with your requirements.

### Mechanical Dimensions

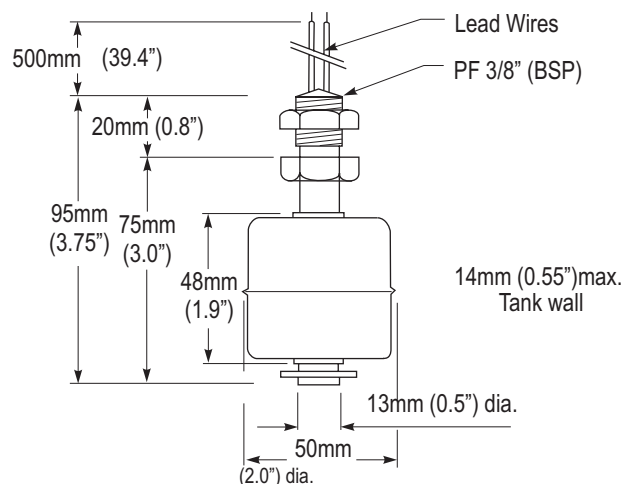

Cynergy3 Components Ltd.  
 7 Cobham Road  
 Ferndown Industrial Estate  
 Wimborne, Dorset BH21 7PE  
 Telephone +44 (0) 1202 897969

Email: sales@cynergy3.com

ISO9001 CERTIFIED

www.cynergy3.com