



# **HAKKO 373** **SELF FEEDER**

## **SELF FEEDER**

# **Instruction Manual**



Thank you for purchasing the HAKKO 373 Self Feeder.  
Please read this manual carefully before operating the HAKKO 373.  
Store the manual in a safe, easily accessible place for future reference.



## **TABLE OF CONTENTS**

PRECAUTIONS .....	1
SPECIFICATIONS .....	1
PART NAMES .....	2
ASSEMBLY .....	3
OPERATION .....	6
TROUBLESHOOTING .....	9
REPLACEMENT PARTS.....	10
OPTIONS & REPLACEMENT PARTS .....	11
PARTS LIST .....	13

# PRECAUTIONS

## CAUTION

- Setting up should be done while the soldering iron is cool, or you may get burnt.
- Do not force the guide pipe bend or turn as this may result in damage.
- Do not operate with tube bending or holding in sharp angle. It may cause to clogging.
- Input of switching is no-voltage input. Do not apply voltage to the jack for switch.
- Periodically, remove the guide pipe and clean out clogged flux.
- Do not force the adjustment screw to adjust the amount of solder return. It may cause to damage.
- This appliance is not intended for use by persons (including children) with reduced physical, sensory or mental capabilities, or lack of experience and knowledge, unless they have been given supervision or instruction concerning use of the appliance by a person responsible for their safety.
- Children should be supervised to ensure that they do not play with the appliance.

# SPECIFICATIONS

## ● Specifications

Power Consumption	6 W
Motor Rate	DC 24 V 3.2W
Solder Feed Time	0~7 sec.
Solder Feed Speed	4.5~26 mm (0.14~1 in.)/sec.
Solder Feed Quantity	0~182 mm (0~7.2 in.)
Solder Return Quantity	0~5 mm (0~0.2 in.) (Fixed Speed)
Outer Dimensions	107(W) x 110(H) x 215(D)
Weight	Approx.1.5 kg/3.3 pounds

\* This product is protected against electrostatic discharge. (See page 9 “CAUTION”)

\* Specifications and design are subject to change without notice.

## ● Usable Solder

Usable solders are as follows. Some of the parts should be changed according to the diameter of solder desired to use.

### CAUTION

1.6 mm dia. lead free solder is not available for use.

## ● Usable Soldering Iron

Soldering Iron
HAKKO 900M (For HAKKO 926, 927, 928)
HAKKO 900L (For HAKKO 926, 927, 928)
HAKKO 902 (For HAKKO 931)
HAKKO 903 (For HAKKO 939)
HAKKO 904 (For HAKKO 929)
HAKKO DASH
HAKKO MACH-I*
HAKKO 907 (For HAKKO 936, 937)
HAKKO 908 (For HAKKO 936, 937)
HAKKO FM-2027 (For HAKKO FM-202, 203, 204, 205)
HAKKO FM-2028 (For HAKKO FX-950, 951, 952)
HAKKO 912 (Long nipple)
HAKKO FX-8301 (For HAKKO FX-838)

\*Operationable only with Foot Switch

Dia. of solder	(mm)	0.6, 0.65, 0.8, 1.0, 1.2, 1.6
	(inch)	0.024, 0.025, 0.031, 0.039, 0.047, 0.063

Maximum quantity of usable solder is 1 kg (2.2 pounds).

# PART NAMES

- ① Jack for Switch
- ② Feed Speed Control Knob
- ③ Feed Time Control Knob
- ④ Mode Switch
- ⑤ Power Switch
- ⑥ Release Lever
- ⑦ Securing Screw
- ⑧ Tension Adjustment Knob
- ⑨ Tension Gear Guide Shaft

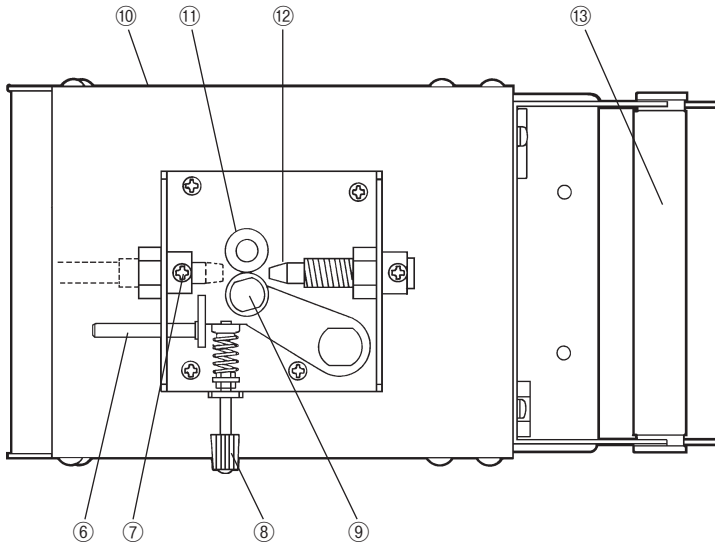
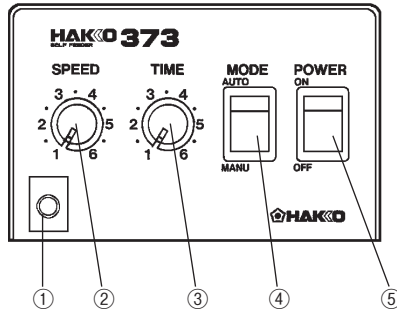

- ⑩ Adjustment for the amount of solder return
- ⑪ Feed Gear
- ⑫ Supply Nozzle
- ⑬ Solder Bobbin Shaft
- ⑭ Solder Dia. Adjustment Ring
- ⑮ Tension Gear

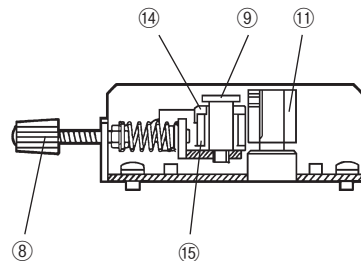

# ASSEMBLY

Make sure the selected guide pipe assembly or tube unit matches the soldering iron and solder diameter to be used.

## 1. Install the Solder Dia. Adjustment Ring

1. Remove the tension gear guide shaft.
2. Attach the solder dia. adjustment ring according to the diameter of your desired solder and attach the tension gear guide shaft.

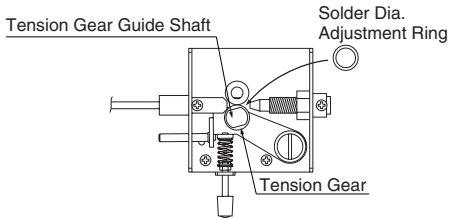

## 2. Attaching the Guide Pipe Assembly

Attach the guide pipe assembly between the nipple (or nut) and handle, and secure it. Washer may need depend on the type of iron. Please refer to the following figure.

HAKKO 900, HAKKO DASH SERIES & 907, 908  
Guide Pipe Assembly

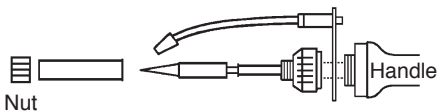

HAKKO 902, 903, 904

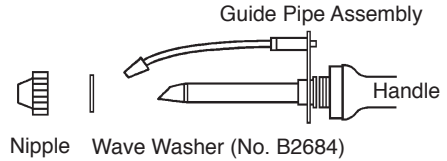

HAKKO MACH-I SERIES

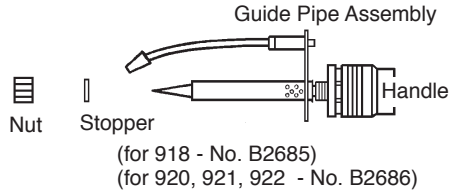

HAKKO FM-2027, FM-2028, FX-8301, 912

Please insert the guide pipe assembly directly in the tube unit, and tighten lightly with a hex wrench (M3).

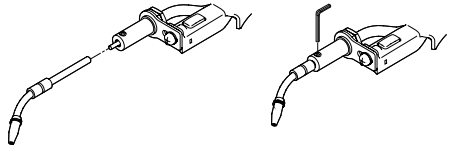

### 3. Attaching the Tube Unit

(a) Attach the Tube to Guide Pipe Assembly.

The tube is double structure. Insert the inside tube into the joint and pass the outer tube over the outside of the joint so that it covers the threaded portion. Do not bend the tube.

(b) Attach the Attachment to the Soldering Iron.

1. Decide from which side of the attachment you will pass the tube. Then, position the attachment so that the tube connects to the guide pipe as straight as possible.

Rear view of attachment

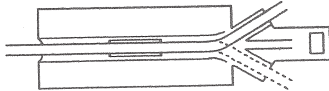

The tube can be passed through either the left or the right side of the attachment. When changing the tube, be careful not to damage the internal wiring.

2. Secure the attachment with the handle and the adhesive tape on the rear of the attachment.

Refer to the following figure and be sure to attach the attachment and the guide pipe at the correct angle.

### 4. Connect the Feed Nozzle

Insert the feed nozzle into the feed unit on the top of the station and tighten the set screw. Do not tighten the set screw excessively or you may crack the tube.

### 5. Connect the Mini Plug

Insert the mini plug into the jack on the front of the station. When use the Mach-I, insert the footswitch plug into the jack on the front of the station.

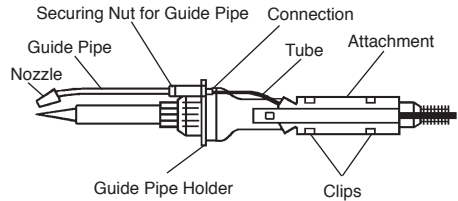

**NOTE** The attachment is not necessary when using the HAKKO Mach I.

# ASSEMBLY

## 6. Setting the Solder

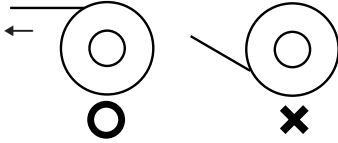

## 7. Changing the Solder Diameter

If there is any solder in the tube, remove it before installing the new solder.

- Pass the solder bobbin shaft through the solder bobbin and attach the shaft to the rear of the station. As shown left, attach the shaft so that the solder is fed from the top of the bobbin.
- Pass the solder through the supply nozzle.
- With pressing release lever, put the inserted solder of approx. 10 mm (0.4 in.) into the feed nozzle through between tension gears.
- Turn the power switch ON and set the mode to **MANUAL**.
- Pressing the feed switch (or footswitch), and feed the solder.

The following parts may need to be changed in order to accommodate a change in the solder diameter or type of soldering iron used.

- |  |                                    |
|--|------------------------------------|
| <input type="checkbox"/> Solder dia. adjustment ring | <input type="checkbox"/> Nozzle    |
| <input type="checkbox"/> Guide pipe assembly         | <input type="checkbox"/> Tube unit |

Change these parts as necessary according to the procedure below.

- Power switch off. Open the release lever and roll back the left solder to the bobbin.
- Remove the tension gear guide shaft, and replace the solder dia. adjustment ring according to desired solder dia. Remove the tension gear guide shaft turning with a spanner or pliers.
- Replace the guide pipe assembly if it is necessary.

## 8. Vertical Mounting

The HAKKO 373 can be mounted vertically. Mount as shown in the figure.

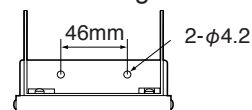

# OPERATION

Solder will be fed by pressing the feed switch (or foot switch).

## ■ MODE

AUTO MODE

If you press the feed switch, solder will be fed with set time and speed independently of length of pressing time.

MANUAL MODE

Solder will be fed with set speed during pressing the feed switch.

## ■ Adjustment of the Nozzle Position

If there is a solder in the guide pipe, pull it out of the pipe and then adjust the nozzle position.

- (a) Loosen the pipe securing nut, turn the guide pipe to adjust the nozzle position, and then tighten the loosened pipe securing nut.

### CAUTION

Do not over tighten the pipe securing nut. Otherwise, the guide pipe can break. This adjustment must be done during the iron tip is cold. Otherwise, you may suffer burns.

## ■ Setting for Feed Time and Feed Speed

Set the speed before the time. For the setting speed, both **AUTO** & **MANUAL** are effective, but only **AUTO** is effective for setting time.

## ■ Adjustment of Tension

When adjust the tension, be sure that not the gear to be slipped during feed solder, or do not force to feed solder slipping gear when solder clog.

Set the tension gear loosely for fine solder ( $\phi 0.6\text{mm}$ ,  $0.8\text{mm}/0.024\text{ in.}$ ,  $0.031\text{ in.}$ ).

Refer to the following chart.

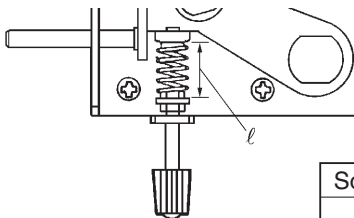

Solder Dia.	$\phi 0.6\text{mm}$	$\phi 1.0\text{mm}$	$\phi 1.6\text{mm}$
$l$	maximum	14mm	10mm

# OPERATION

## ■ Adjustment for the Amount of Solder Return

After feed solder, the specified length of solder can be returned. Soldering robots may need this solder return function. Amount of solder return is adjustable within 0~5 mm (0~0.2 in.). Solder should be taken up if the amount of solder return is bigger than the amount of solder feed. Please set the amount of solder return as small as possible. If the tip of the returning solder reaches to the nozzle, flux will easily accumulate on it. Do not set the return amount causing this condition. To adjust the return amount, insert a driver into a adjustment hole on the side of the station. Turn the driver left for smaller or turn it right for bigger amount.

## ■ Usage of Iron Holder

- HAKKO 926

If you use HAKKO 926, refer to the following figure to set the iron holder. (As for the HAKKO 926, the setting is available only on its left.)

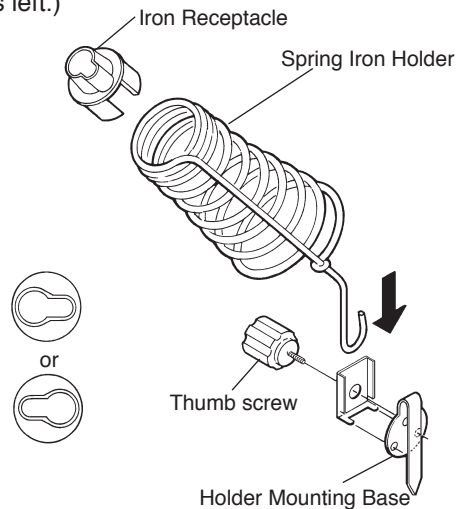

Set the iron receptacle in the spring iron holder keeping the iron tip and the guide pipe horizontally.



- HAKKO 631

- HAKKO 907, 908

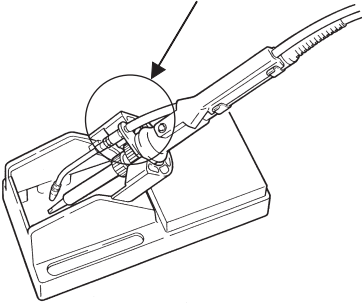

- Iron holder for the FM-2027, FM-2028, FX-8301, 912

Simply replace the iron holder if you use with iron holder HAKKO 631 for except HAKKO 926.

Place the soldering iron in the iron holder so that the right side of the guide pipe holder fits to the right side of the iron receptacle.

When you want to fit it to the left side of the iron receptacle, remove the securing nut for the guide pipe and the connection; then reattach them in the opposite side.

Replace the spring holder with the spring holder included in the set before placing the iron in the iron holder.

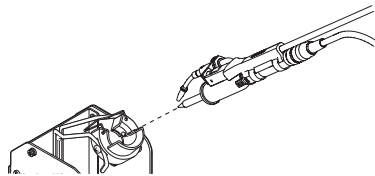
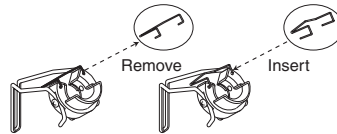

# TROUBLESHOOTING

If the solder can not be fed smoothly, please check following points.

- Are you using proper parts according to the diameter of solder?
- Did you adjust the tension properly?
- Is the tube bent or transformed?
- Is solder adhered at the feed gear or the tension gear?
- Is the nozzle clogged with flux?
- Is the mini-plug correctly connected?
- Is the fuse blown?
- Is the power cord correctly connected?

## CAUTION

This product includes such features as electrically conductive plastic parts and grounding of the handpiece and station as measures to protect the device to be soldered from the effects of static electricity. Be sure to observe the following instructions:

1. The handle and other plastic parts are not insulators, they are conductors.  
When replacing parts or repairing, take sufficient care not to expose live electrical parts or damage insulation materials.
2. Be sure to ground the unit during use.

### ■ 中國RoHS: 產品中有毒有害物質或元素的名稱及含量

部件名稱	有毒有害物質或元素					
	鉛(Pb)	汞(Hg)	鎘(Cd)	六價鉻 (Cr(VI))	多溴聯苯 (PBB)	多溴二苯醚 (PBDE)
馬達	×	○	○	○	○	○
輸送組合	×	○	○	○	○	○
錫線軸	×	○	○	○	○	○
插頭	×	○	○	○	○	○
保險絲支架	×	○	○	○	○	○
電路板	×	○	○	○	○	○

○ : 表示該有毒有害物質在該部件所有均質材料中的含量均在SJ/T 11363-2006標準規定的限量要求以下。  
× : 表示該有毒有害物質至少在該部件的某一均質材料中的含量超出SJ/T 11363-2006標準規定的限量要求。

※ 各言語（日本語、英語、中國語、フランス語、ドイツ語、韓国語）の取扱説明書は以下のURL、HAKKO Document Portalからダウンロードしてご覧いただけます。  
（商品によっては設定の無い言語がありますが、ご了承ください）  
\* 各國語言(日語、英語、中文、法語、德語、韓語)的使用說明書可以通過以下網站的HAKKO Document Portal 下載參閱。  
（有一部分的產品沒有設定外語對應，請見諒）  
\* Instruction manual for the language, Japanese, English, Chinese, French, German and Korean can be downloaded from the following URL, HAKKO Document Portal.  
(Please note that some language may not be available depending on the product.)

  
<https://doc.hakko.com>

# REPLACEMENT OF PARTS

## 1. When you change the Solder Diameter

Please replace the parts indicated on the following chart when you change solder diameter.

Changing matter	Solder Dia. Adjustment Ring	Nozzle	Guide Pipe	Tube Unit
From the range of 0.6~1.0mm to the range of 0.6~1.0mm	replace	replace	same	same
From the range of 1.2~1.6mm to the range of 1.2~1.6mm	replace	replace	same	same
From the range of 0.6~1.0mm to the range of 1.2~1.6mm	replace	replace	replace	replace
From the range of 1.2~1.6mm to the range of 0.6~1.0mm	replace	replace	replace	replace

## 2. When you change the Soldering Iron

Please replace the tube unit and guide pipe assembly, when you change the soldering iron. It is not necessary to replace the parts if the items are in the same frame in the following chart. Foot switch is necessary if you use the HAKKO MACH-I.

Tube Unit	900M, 900L, N452, N453, N454	902, 903, 904	918, 920, 921, 922	907, 908
Guide Pipe Assembly	N452, N453, 900M	N454, 900L	920, 921, 922	918 902, 903, 904
				907 908

# OPTIONS & REPLACEMENT PARTS

Part No.	Part Name	Dia. of Solder	Soldering Iron
B1626	Solder Dia. Adjustment Ring	0.6, 0.65mm	-
B1627	Solder Dia. Adjustment Ring	0.8mm	-
B1628	Solder Dia. Adjustment Ring	1.0mm	-
B1629	Solder Dia. Adjustment Ring	1.2mm	-
B1630	Solder Dia. Adjustment Ring	1.6mm	-
B1631	Tube Unit A/with Switch	0.6~1.0mm	900M, 900L, DASH
B1672	Tube Unit B/with Switch	1.2~1.6mm	
B1632	Tube Unit C	0.6~1.0mm	MACH-I
B1673	Tube Unit D	1.2~1.6mm	
B1957	Tube Unit E/with Switch	0.6~1.0mm	902, 903, 904
B1958	Tube unit F/with Switch	1.2~1.6mm	
B2143	Tube Unit J/with Switch	0.6~1.0mm	907, 908
B2144	Tube Unit K/with Switch	1.2~1.6mm	
B3477	Tube unit M/with Switch	0.6~1.0mm	FM-2027,FM-2028
B3478	Tube unit N/with Switch	1.2mm	
B3479	Tube unit P/with Switch	0.6~1.0mm	912
B3480	Tube unit Q/with Switch	1.2mm	
B3563	Tube unit R/with Switch	0.6~1.0mm	FX-8301
B3564	Tube unit S/with Switch	1.2~1.6mm (373) 1.2mm (374)	
B3565	Tube unit T/with Switch	1.6mm (374)	
B1674	Guide Pipe Asse'y	0.6, 0.65mm	900M, N452, N453
B1675	Guide Pipe Asse'y	0.8mm	
B1676	Guide Pipe Asse'y	1.0mm	
B1677	Guide Pipe Asse'y	1.2mm	
B1678	Guide Pipe Asse'y	1.6mm	
B1679	Guide Pipe Asse'y	0.6, 0.65mm	900L, N454
B1680	Guide Pipe Asse'y	0.8mm	
B1681	Guide Pipe Asse'y	1.0mm	
B1682	Guide Pipe Asse'y	1.2mm	
B1683	Guide Pipe Asse'y	1.6mm	
B1684	Guide Pipe Asse'y	0.6, 0.65mm	920, 921, 922
B1685	Guide Pipe Asse'y	0.8mm	
B1686	Guide Pipe Asse'y	1.0mm	
B1687	Guide Pipe Asse'y	1.2mm	
B1688	Guide Pipe Asse'y	1.6mm	
B1689	Guide Pipe Asse'y	0.6, 0.65mm	918
B1690	Guide Pipe Asse'y	0.8mm	
B1691	Guide Pipe Asse'y	1.0mm	
B1692	Guide Pipe Asse'y	1.2mm	
B1693	Guide Pipe Asse'y	1.6mm	
B1694	Guide Pipe Asse'y	0.6, 0.65mm	902, 903, 904
B1695	Guide Pipe Asse'y	0.8mm	
B1696	Guide Pipe Asse'y	1.0mm	
B1697	Guide Pipe Asse'y	1.2mm	
B1698	Guide Pipe Asse'y	1.6mm	
B2146	Guide Pipe Asse'y	0.6, 0.65mm	907
B2147	Guide Pipe Asse'y	0.8mm	
B2148	Guide Pipe Asse'y	1.0mm	
B2149	Guide Pipe Asse'y	1.2mm	
B2150	Guide Pipe Asse'y	1.6mm	

Part No.	Part Name	Dia. of Solder	Soldering Iron
B2151	Guide Pipe Asse'y	0.6, 0.65mm	908
B2152	Guide Pipe Asse'y	0.8mm	
B2153	Guide Pipe Asse'y	1.0mm	
B2154	Guide Pipe Asse'y	1.2mm	
B2155	Guide Pipe Asse'y	1.6mm	
B3481	Guide Pipe Asse'y	0.6mm	FM-2027, FM-2028, 912
B3482	Guide Pipe Asse'y	0.8mm	
B3483	Guide Pipe Asse'y	1.0mm	
B3484	Guide Pipe Asse'y	1.2mm	
B3566	Guide Pipe Asse'y	0.6, 0.65*mm	FX-8301
B3567	Guide Pipe Asse'y	0.8mm	
B3568	Guide Pipe Asse'y	1.0mm	
B3569	Guide Pipe Asse'y	1.2mm	
B3570	Guide Pipe Asse'y	1.6mm (373)	
B3571	Guide Pipe Asse'y	1.6mm (374)	
B1699	Nozzle	0.6, 0.65mm	-
B1700	Nozzle	0.8mm	-
B1701	Nozzle	1.0mm	-
B1702	Nozzle	1.2mm	-
B1703	Nozzle	1.6mm	-
B1704	Guide Pipe A	0.6~1.0mm	900M, 920, 921, 922
B1705	Guide Pipe B	1.2~1.6mm	N452, N453, 907
B1706	Guide Pipe C	0.6~1.0mm	900L, 918, N454, 908
B1707	Guide Pipe D	1.2~1.6mm	902, 903, 904
B1708	Guide Pipe E	0.6~1.0mm	
B1709	Guide Pipe F	1.2~1.6mm	FM-2027, FM-2028, 912
B3485	Guide Pipe J	0.6~1.0mm	
B3486	Guide Pipe K	1.2mm	902, 904
B2684	Wave washer	-	
B2685	Stopper	-	918
B2686	Stopper	-	920, 921, 922
B1647	Spring Iron Holder A	-	926
B1648	Spring Iron Holder B	-	927, 928, 929, 931
B1649	Foot Switch	-	-
B1650	Clip A/1 pc.	-	900M, 900L, DASH
B1956	Clip B/1 pc.	-	902, 903, 904
B2158	Clip C/1 pc.	-	907, 908, FX-8301
B3487	Clip D/1 pc.	-	FM-2027, FM-2028
B3488	Clip E/1 pc.	-	912
B3489	Retaining clip	-	FH-100, FH-200
631-07	HAKKO631 Iron Holder	-	DASH, MACH-I
B1863	Mini-plug	-	-
B1805	Iron Receptacle	-	-
C1234	Feeder Pen A	0.6~1.0mm	-
C1235	Feeder Pen B	1.2~1.6mm	-
B2124	Feeder Switch	-	-
B1290	Joint band/5 bands	-	-

\*Dia. of solder 0.65mm is available for HAKKO 373 only.

■ 900M, 900L are Iron Parts for HAKKO 926, 927, 928.

■ 902 is Iron Part for HAKKO 931.

■ 903 is Iron Part for HAKKO 929, 939 (120V).

■ 904 is Iron Part for HAKKO 929 (100, 110, 220, 230, 240V).

■ 918, 920, 921, 922 are Parts No. of HAKKO MACH-I series. MACH-I means applicable for all items of HAKKO MACH-I series.

■ N452, N453, N454 are Parts No. of HAKKO DASH series. DASH means applicable for all items of HAKKO DASH series.

■ 907, 908 are Iron Parts for HAKKO 936, 937.

# PARTS LIST

Item No.	Part No.	Part Name	Description
1	B1897	Cover for Feeding Unit	
2	B1882	Tension Gear Guide Shaft	
3	B1626	Solder Dia. Adjustment Ring	for 0.6, 0.65mm
	B1627	Solder Dia. Adjustment Ring	for 0.8mm
	B1628	Solder Dia. Adjustment Ring	for 1.0mm
	B1629	Solder Dia. Adjustment Ring	for 1.2mm
	B1630	Solder Dia. Adjustment Ring	for 1.6mm
4	B1885	Tension Gear	
5	B1886	Tension Lever Fixing Shaft	
6	B1908	Washer	for Wave Washer
7	B1894	Tension Lever	w/Screw
8	B1883	Tension Spring	
9	B1881	Feed Gear	w/Screw
10	B1887	Washer	for Tension Lever Fixing Guide
11	B1888	Tension Lever Fixing Guide	
12	B1889	Tension Lever Fixing Washer	
13	B1890	Nozzle Support	w/Nut, Screw
14	B1892	Supply Nozzle	
15	B1891	Motor Fixing Plate	
16	B1893	Release Lever	w/Washer
17	B1884	Tension Adjustment Knob	w/Nuts
18	B1880	Motor	
19	B1898	Cover	
20	B1900	Transformer	100V-24V
	B1909	Transformer	110V-24V
	B1910	Transformer	120V-24V
	B1911	Transformer	220, 230V-24V
	B1912	Transformer	240V-24V
21	B1901	Solder Bobbin Shaft	
22	B1902	Solder Bobbin Support	
23	B1899	P.W.B.	w/Potentiometers
24	B1041	Fuse Holder	w/o Fuse
	B1134	Fuse Holder (S)	w/o Fuse
25	B1907	Fuse	125V-1A/100,110,120V
	B1138	Fuse	250V-1A/220,230,240V
	B1139	Fuse	250V-1A (S)/220,230V
26	B1895	Chassis Support Plate	w/Rubber Stoppers
27	B1904	Knob	
28	B1903	Mini Jack	
29	B1906	Switch	
30	B1487	Power Switch	100-120V
	B2604	Power Switch	220-240V
31	B1197	Potentiometer for Feed Speed Control	5K $\Omega$ , w/Nut
32	B1905	Potentiometer for Feed Time Control	1M $\Omega$ , w/Nut
33	B1896	Chassis	w/Rubber Stoppers
34	B1037	Rubber Stopper	Set of 4
35	B1114	Locking Spacer	Set of 4
36	B1208	Cord Stopper	
37	B1163	3 wired cord & American plug	100V
	B1007	3 wired cord but no plug	
	B1168	3 wired cord & American plug	For U.S.A.
	B1169	3 wired cord & European plug	
	B1214	3 wired cord & Australian plug	
	B1964	3 wired cord & BS plug	
	B2087	3 wired cord & BS plug	CE
	B3509	3 wired cord & American plug	
38	B2684	Wave Washer	

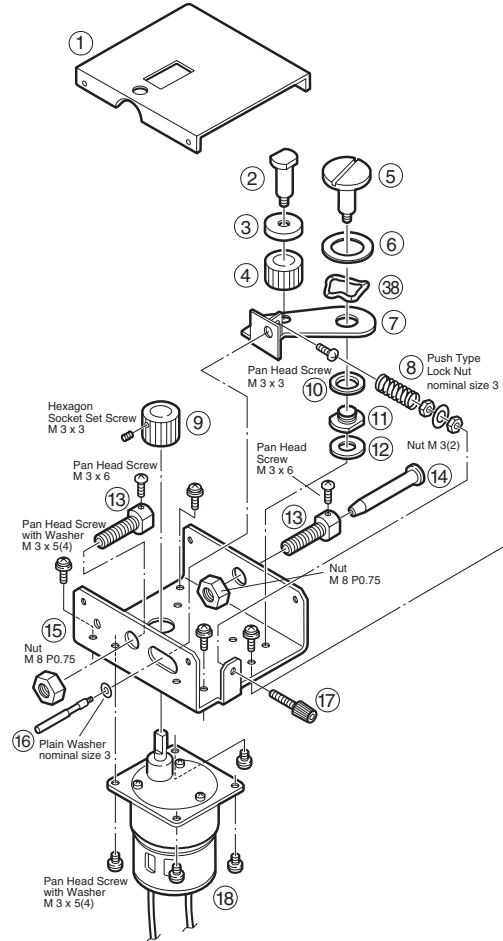

Note: Spare or repair parts do not include mounting screws, if they are not listed on the description. Screws must be ordered separately.

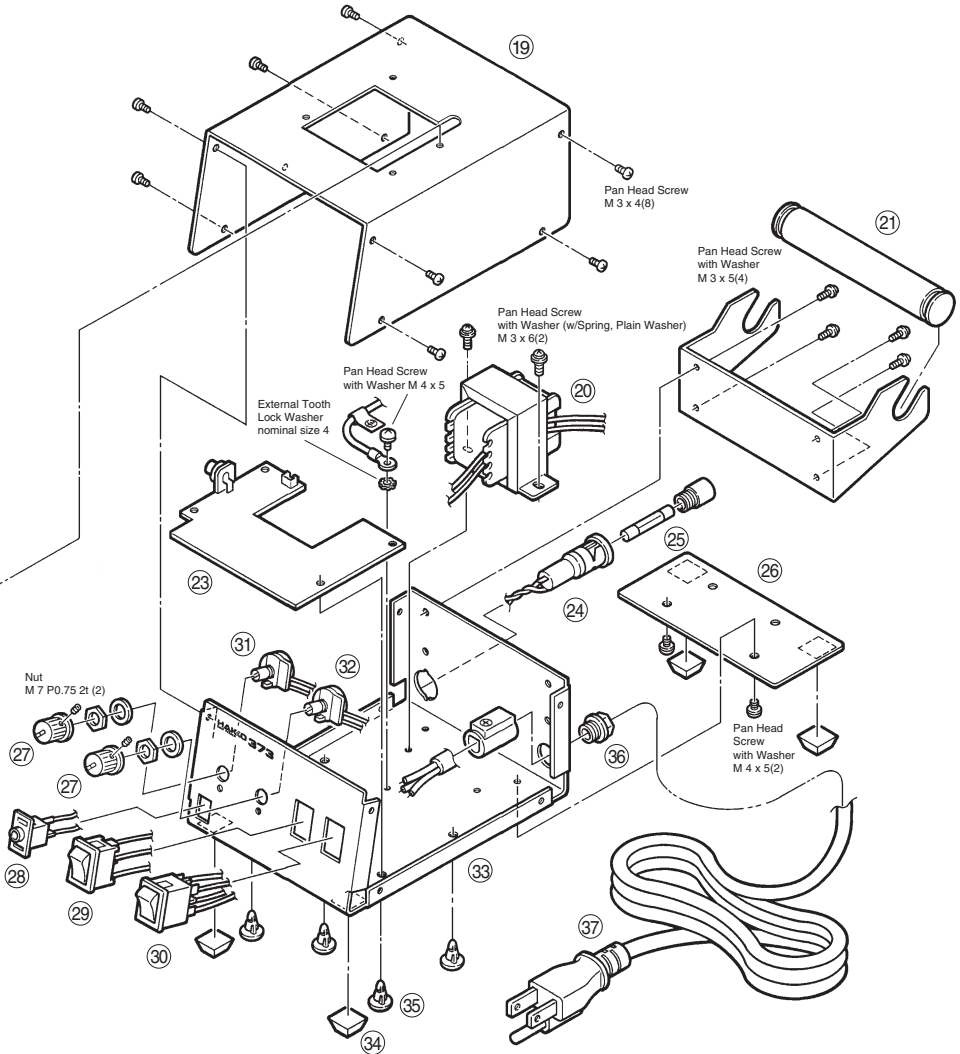



**HAKKO CORPORATION**

**HEAD OFFICE**

TEL: +81-6-6561-3225 FAX: +81-6-6561-8466  
<http://www.hakko.com> E-mail: [sales@hakko.com](mailto:sales@hakko.com)

**OVERSEAS AFFILIATES**

**U.S.A.: AMERICAN HAKKO PRODUCTS, INC.**  
TEL: (661) 294-0090 FAX: (661) 294-0096

Toll Free (800)88-HAKKO  
4 2 5 5 8  
<http://www.hakkousa.com>

**HONG KONG: HAKKO DEVELOPMENT CO., LTD.**

TEL: 2811-5588 FAX: 2590-0217

<http://www.hakko.com.hk>  
E-mail: [info@hakko.com.hk](mailto:info@hakko.com.hk)

**SINGAPORE: HAKKO PRODUCTS PTE., LTD.**

TEL: 6748-2277 FAX: 6744-0033

<http://www.hakko.com.sg>  
E-mail: [sales@hakko.com.sg](mailto:sales@hakko.com.sg)

Please access to the following address for the other Sales affiliates.

**<http://www.hakko.com>**