

N Coaxial Connectors

The Amphenol N connectors with screw coupling are fully interchangeable with N connectors made to the MIL-C-39012 specification. Designed for use in all systems where very good R.F. and mechanical performance is critical, whether it be at low or high frequencies.

Plating for intermodulation problems

Intermodulation problems have long been a serious concern for the telecommunications market. The elimination of all nickel plating on N series connectors has gone a long way to solve this problem. Amphenol offers both silver-plated (no nickel undercoat on body or under 30 μ " gold center contact) and Nexcote-plated connectors. Nexcote is our trade name for the popular white bronze plating, and is fully compatible with all other commercial tri-alloy platings on the market.

Electrical Specifications

Impedance	50 ohm nominal
Frequency	0-11 GHz
Voltage Rating	1500 Volts peak
Dielectric Withstanding Voltage	2500 Volts rms
VSWR	1.3 max. 0-11 GHz
Contact Resistance	Center contact 1.0 milliohm Outer contact 0.2 milliohm
Insulation Resistance	5000 megohms (min)

Note: 75 ohm series connectors are not intermateable with the 50 ohm series.

Material Specifications

Parts Name		Material	Finish
Center Contact	Male	Brass	Gold or Silver plated
	Female	Phosphor Bronze (nominal) or Beryllium Copper	Gold or Silver plated
Metal parts		Brass	Nickel*
Insulators		Teflon	None
Clamp gaskets		Sillicone rubber, Synthetic rubber	None
Crimp ferrules		Annealed copper	Nickel*

N Coaxial Connectors

Interface mating dimensions

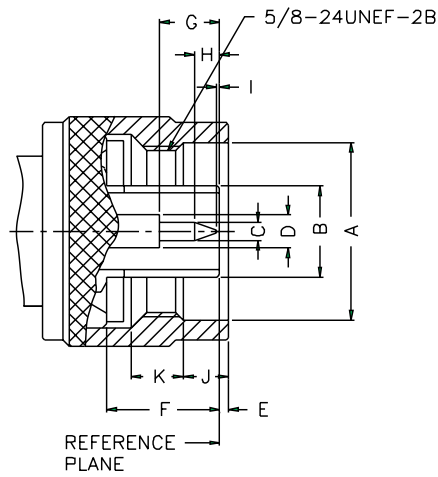

Plug

Letter	Millimeters [Inches]	
	Minimum	Maximum
A	16.00 [.630]	-
B	-	8.38 [.330]
C	1.60 [.063]	1.68 [.066]
D	3.00 [.118]	3.15 [.124]
E	0.41 [.016]	1.52 [.060]
F	10.11 [.398]	10.46 [.412]
G	5.33 [.210]	5.84 [.230]
H	3.30 [.130]	4.32 [.170]
I	0.08 [.003]	-
J	4.01 [.158]	4.27 [.168]
K	4.50 [.177]	5.00 [.197]

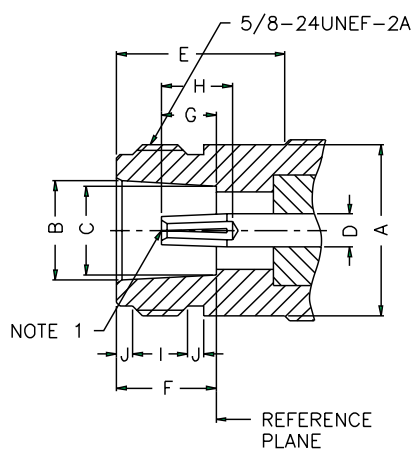

Jack

Letter	Millimeters [Inches]	
	Minimum	Maximum
A	-	15.93 [.628]
B	8.53 [.336]	8.74 [.344]
C	8.03 [.316]	8.13 [.320]
D	3.00 [.118]	3.15 [.124]
E	10.72 [.422]	-
F	9.04 [.356]	9.19 [.362]
G	4.75 [.187]	5.26 [.207]
H	5.33 [.210]	-
I	4.37 [.172]	5.13 [.202]
J	1.19 [.047]	1.96 [.077]

All connector bodies, unless otherwise noted, are nickel plated and all contacts are gold plated 3µ".
 All insulators are Teflon.
 Silver plating is available. Please contact Amphenol for samples and quotes.
 All dimensions are in millimeters and [inches].

Crimp Attachment for Flexible Cable and Direct Solder for Semi-Rigid Cable

Straight Crimp Plug - Captive Contact - Standard Cable

P.N.	Cable Group	Plt.	Ins.	Imp.	Crimp Tool
N1121A1-NT3G-1-50	01	Nickel	Teflon	50	4
N1121A1-NT3G-1A-50	01A	Nickel	Teflon	50	*
N1121A1-NT3G-1B-50	01B	Nickel	Teflon	50	4
N1121C1-NT3G-2-50	02	Nickel	Teflon	50	4
N1121A1-NT3G-3-50	03	Nickel	Teflon	50	4
N1121G1-NT3G-5-50	05	Nickel	Teflon	50	1
N1121G1-NT3G-5A-50	05A	Nickel	Teflon	50	1
N1121A1-NT3G-7-50	07	Nickel	Teflon	50	6
N1121A1-NT3G-7A-50	07A	Nickel	Teflon	50	6 + 4
N1121A1-NT3G-7B-50	07B	Nickel	Teflon	50	4
N1121A2-002-NT3G-7C-50	07C	Nickel	Teflon	50	6
N1121A2-NT3G-7D-50	07D	Nickel	Teflon	50	6
N1121A1-NT3G-8-50	08	Nickel	Teflon	50	5
N1121A4-003-NT3G-17-50	17	Nickel	Teflon	50	.610 hex
N1121A1-NT3G-1839-50	Gore 1839	Nickel	Teflon	50	5
N1121C5-NT3G-LMR500-50	Times LMR500	Nickel	Teflon	50	.610 hex

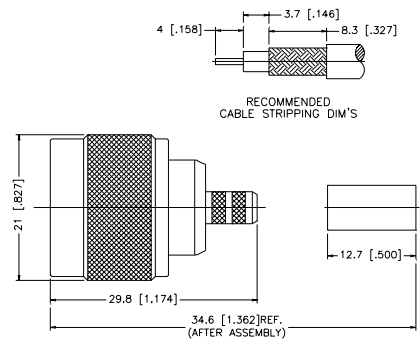

Assembly Instruction J - page 232

Straight Solder Plug - Semi-Rigid Cable

P.N.	Cable Group	Plt.	Ins.	Imp.	Crimp Tool
N1181A1-3G/NT3G-10-50	10	Nickel/Gold	Teflon	50	N/A
N1181B1-3G/NT3G-11-50	11	Nickel/Gold	Teflon	50	N/A
N1181A2-3G/NT3G-12-50	12	Nickel/Gold	Teflon	50	N/A

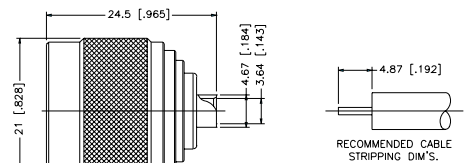

Assembly Instruction G - page 229

Crimp Attachment for Flexible Cable and Direct Solder for Semi-Rigid Cable

Crimp Plug - Ethernet Cable

P.N.	Cable Group	Plt.	Ins.	Imp.	Crimp Tool
N1121A1-NT3G-9880-50	9880	Nickel	Teflon	50	6
N1121A1-NT3G-89880-50	89880	Nickel	Teflon	50	6

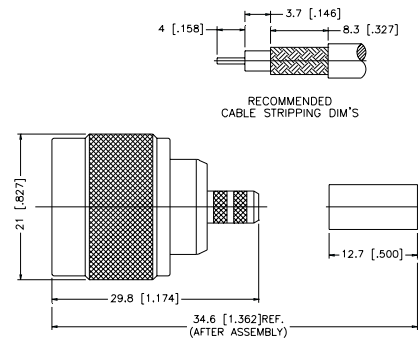

Assembly Instruction J - page 232

Right Angle Crimp Plugs - Standard Cable

P.N.	Cable Group	Plt.	Ins.	Imp.	Crimp Tool
N1112B1-001-NT3G-1-50	01	Nickel	Teflon	50	3 or 4
N1112B1-001-NT3G-1A-50	01A	Nickel	Teflon	50	3 or 4
N1112B1-NT3G-1B-50	01B	Nickel	Teflon	50	3 or 4
N1112A1-NT3G-3-50	03	Nickel	Teflon	50	4
N1112E2-NT3G-5-50	05	Nickel	Teflon	50	3
N1112E1-NT3G-5A-50	05A	Nickel	Teflon	50	1 or 2
N1112B2-002-NT3G-7-50	07	Nickel	Teflon	50	6
N1112B2-001-NT3G-7A-50	07A	Nickel	Teflon	50	6
N1112B2-NT3G-7B-50	07B	Nickel	Teflon	50	4
N1112B4-NT3G-17-50	17	Nickel	Teflon	50	.610 hex
N1112B4-NT3G-LMR500-50	LMR500	Nickel	Teflon	50	.600 hex

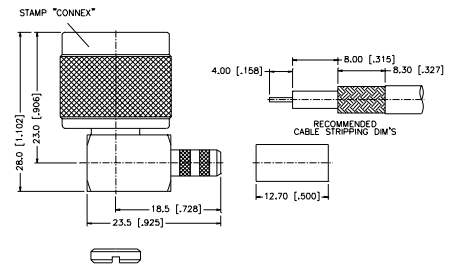

Assembly Instruction I - page 231

Right Angle Solder Plug - Semi-Rigid Cable

P.N.	Cable Group	Plt.	Ins.	Imp.	Crimp Tool
N1182A1-NT3G-10-50	10	Nickel	Teflon	50	N/A
N1182A1-NT3G-11-50	11	Nickel	Teflon	50	N/A
N1182A1-NT3G-12-50	12	Nickel	Teflon	50	N/A

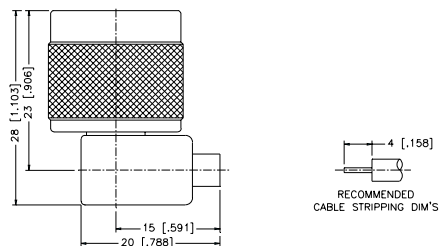

Assembly Instruction D - page 226

Crimp Jack - Captive Contact - Standard Cable

P.N.	Cable Group	Plt.	Ins.	Imp.	Crimp Tool
N6121A1-NT3G-1-50	01	Nickel	Teflon	50	4
N6121A1-NT3G-1A-50	01A	Nickel	Teflon	50	4
N6121A1-NT3G-1B-50	01B	Nickel	Teflon	50	4
N6121A1-NT3G-3-50	03	Nickel	Teflon	50	4
N6121G1-NT3G-5-50	05	Nickel	Teflon	50	1
N6121G1-NT3G-5A-50	05A	Nickel	Teflon	50	2 + 1
N6121A1-NT3G-7-50	07	Nickel	Teflon	50	6
N6121A1-NT3G-7A-50	07A	Nickel	Teflon	50	6 + 4
N6121A1-NT3G-7B-50	07B	Nickel	Teflon	50	4
N6121A2-NT3G-7C-50	07C	Nickel	Teflon	50	6
N6121A4-001-NT3G-17-50	17	Nickel	Teflon	50	.610 hex
N6121C5-NT3G-LMR500-50	LMR500	Nickel	Teflon	50	.600 hex

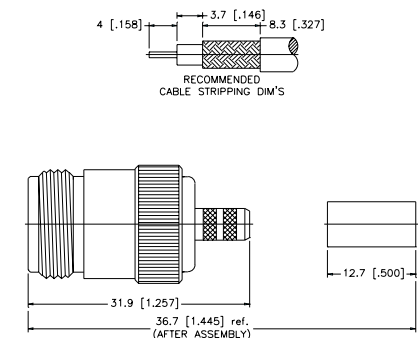

Assembly Instruction J - page 232

Crimp Attachment for Flexible Cable and Direct Solder for Semi-Rigid Cable

Solder Jack - Semi-Rigid Cable

P.N.	Cable Group	Plt.	Ins.	Imp.	Crimp Tool
N6181A1-N/3GT3G-10-50	10	Nickel/Gold	Teflon	50	N/A
N6181A1-N/3GT3G-11-50	11	Nickel/Gold	Teflon	50	N/A

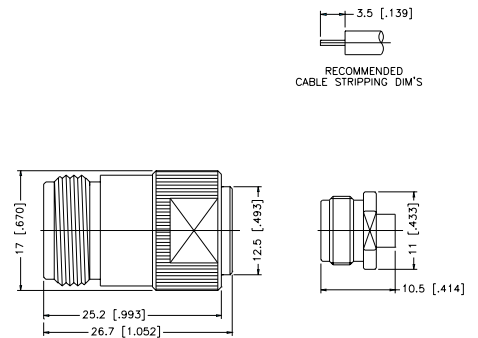

Assembly Instruction G - page 229

Bulkhead Crimp Jack - Captive Contact - Standard Cable

P.N.	Cable Group	Plt.	Ins.	Imp.	Crimp Tool
N6421A1-NT3G-1-50	01	Nickel	Teflon	50	3 or 4
N6421A1-NT3G-1A-50	01A	Nickel	Teflon	50	4
N6421A1-NT3G-1B-50	01B	Nickel	Teflon	50	4
N6421C1-001-NT3G-2-50	02	Nickel	Teflon	50	4
N6421C1-001-NT3G-3-50	03	Nickel	Teflon	50	4
N6421G1-NT3G-5-50	05	Nickel	Teflon	50	1 or 2
N6311A1-NT3G-5-50	05	Nickel	Teflon	50	1
Front Mount					
N6421G1-001-NT3G-5A-50	05A	Nickel	Teflon	50	2
N6421A1-NT3G-7-50	07	Nickel	Teflon	50	6 + 1
N6421A1-NT3G-7A-50	07A	Nickel	Teflon	50	6 + 1
N6421A1-NT3G-7B-50	07B	Nickel	Teflon	50	4
N6421A2-NT3G-7C-50	07C	Nickel	Teflon	50	6
N6421A4-NT3G-17-50	17	Nickel	Teflon	50	.610 hex
N6421C5-NT3G-LMR500-50	LMR500	Nickel	Teflon	50	.600 hex

Remark: Rear Mount, except where indicated

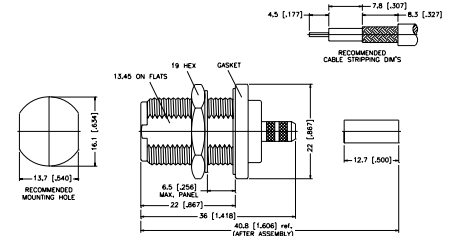

Assembly Instruction J - page 232

Bulkhead Solder Jack - Semi-Rigid Cable

P.N.	Cable Group	Plt.	Ins.	Imp.	Crimp Tool
N6481A2-001-NT3G-10-50	10	Nickel	Teflon	50	N/A
N6381A1-N/3GT3G-10-50	10	Nickel/Gold	Teflon	50	N/A
Front Mount					
N6481A2-NT3G-11-50	11	Nickel	Teflon	50	N/A
N6381A1-N/3GT3G-11-50	11	Nickel/Gold	Teflon	50	N/A
Front Mount					
N6481A2-NT3G-12-50	12	Nickel	Teflon	50	N/A

Remark: Rear Mount, except where indicated

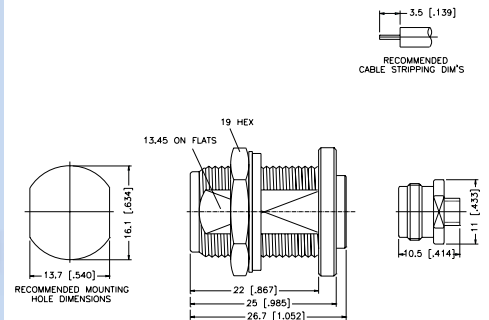

Assembly Instruction G - page 229

Bulkhead Crimp Jack - Ethernet Cable

P.N.	Cable Group	Plt.	Ins.	Imp.	Crimp Tool
N6421A1-NT3G-9880-50	9880	Nickel	Teflon	50	6
N6421A1-NT3G-89880-50	89880	Nickel	Teflon	50	6

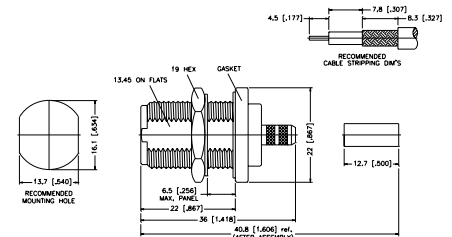

Crimp On
Assembly Instruction J - page 232

Crimp Attachment for Flexible Cable and Direct Solder for Semi-Rigid Cable

Bulkhead Clamp Jack - Rear Mount - Miniature Cable

P.N.	Cable Group	Plt.	Ins.	Imp.	Crimp Tool
N6441H1-001-NT30G-5-50 Rear Mount Flatwasher	05	Nickel	Teflon	50	N/A
N6441H1-002-NT30G-5-50 Rear Mount Starwasher	05	Nickel	Teflon	50	N/A

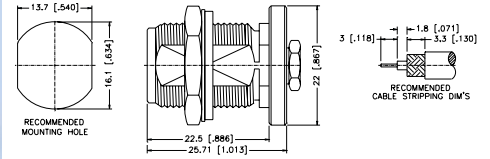

Assembly Instruction N - page 236

Bulkhead Clamp Jack - Front Mount - Miniature Cable

P.N.	Cable Group	Plt.	Ins.	Imp.	Crimp Tool
N6341A1-001-NT3G-5-50	05	Nickel	Teflon	50	N/A

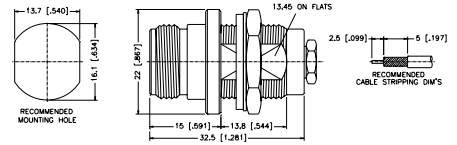

Assembly Instruction N - page 236

Straight Crimp Panel Jack - Captive Contact - Flexible Cable

P.N.	Cable Group	Plt.	Ins.	Imp.	Crimp Tool
N6521A1-NT3G-1-50	01	Nickel	Teflon	50	4
N6521A1-NT3G-1A-50	01A	Nickel	Teflon	50	4
N6521A1-NT3G-1B-50	01B	Nickel	Teflon	50	4
N6521G1-NT3G-5-50	05	Nickel	Teflon	50	1 or 2
N6521G1-NT3G-5A-50	05A	Nickel	Teflon	50	2
N6521A1-NT3G-7-50	07	Nickel	Teflon	50	4
N6521A1-NT3G-7A-50	07A	Nickel	Teflon	50	6

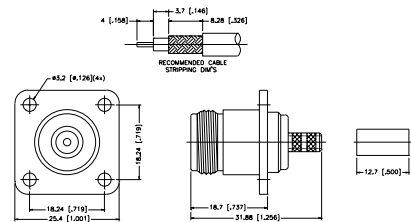

Assembly Instruction J - page 232

Straight Solder Panel Jack - Semi-Rigid Cable

P.N.	Cable Group	Plt.	Ins.	Imp.	Crimp Tool
N6581A1-NT3G-10-50	10	Nickel	Teflon	50	N/A
N6581A1-NT3G-11-50	11	Nickel	Teflon	50	N/A

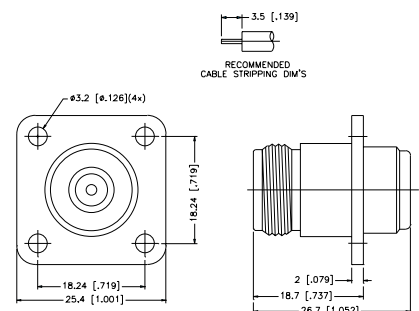

Assembly Instruction E - page 227

Clamp Attachment for Flexible Cable

Straight Solder Plug - Captive Contact - Standard Cable

P.N.	Cable Group	Plt.	Ins.	Imp.	Crimp Tool
N1141A1-NT3G-1-50	01	Nickel	Teflon	50	N/A
N1141A1-NT3G-3-50	03	Nickel	Teflon	50	N/A

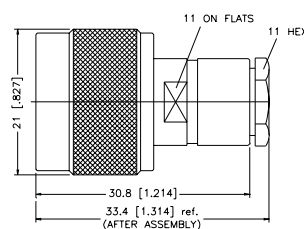
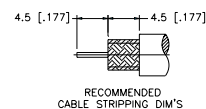

Assembly Instruction M - page 235

P.N.	Cable Group	Plt.	Ins.	Imp.	Crimp Tool
N1141A2-NT3G-7-50	07	Nickel	Teflon	50	N/A

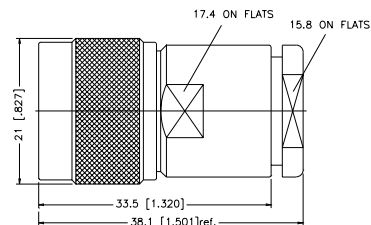
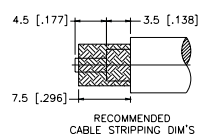

Assembly Instruction M - page 235

Straight Solder Jack - Captive Contact - Standard Cable

P.N.	Cable Group	Plt.	Ins.	Imp.	Crimp Tool
N6141A1-NT3G-1-50	01	Nickel	Teflon	50	N/A
N6141A1-NT3G-3-50	03	Nickel	Teflon	50	N/A

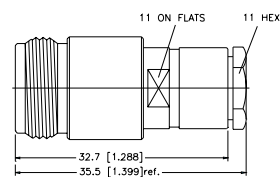
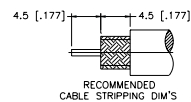

Assembly Instruction M - page 235

P.N.	Cable Group	Plt.	Ins.	Imp.	Crimp Tool
N6141A2-NT3G-7-50	07	Nickel	Teflon	50	N/A

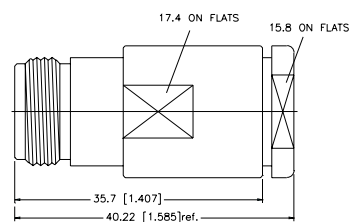
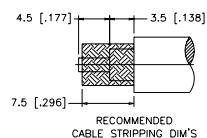

Assembly Instruction M - page 235

Bulkhead Mount Solder Receptacles

Bulkhead Receptacle - Front Mount

P.N.	Cable Group	Plt.	Ins.	Imp.	Crimp Tool
N6351A1-NT3G-50	N/A	Nickel	Teflon	50	N/A

Remark: Non-hermetic

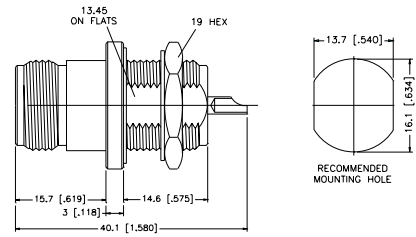

Bulkhead Receptacle - Front Mount

P.N.	Cable Group	Plt.	Ins.	Imp.	Crimp Tool
N6351B1-005-NT3G-50	N/A	Nickel	Teflon	50	N/A

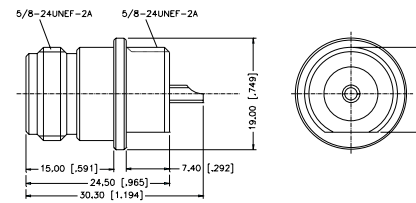

Panel Mount/Solder Receptacles

Panel Receptacle Jack - Exposed TFE Type

P.N.	Cable Group	Plt.	Ins.	Imp.	Crimp Tool
N6551E1-NT3G-50	N/A	Nickel	Teflon	50	N/A
N6551E1-015-NT20G-50	N/A	Nickel	Teflon	50	N/A

Remark: With gasket.
Extended Teflon insulation available in various lengths.
Contact Amphenol for part number and availability.

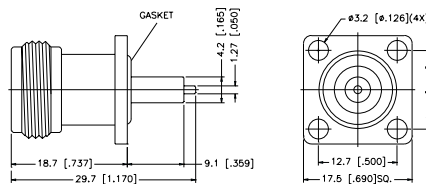

Panel Receptacle Plug - Exposed TFE Type

P.N.	Cable Group	Plt.	Ins.	Imp.	Crimp Tool
N1551E1-NT3G-50	N/A	Nickel	Teflon	50	N/A

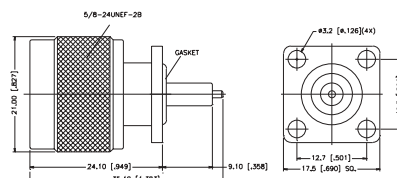

Panel Receptacle Plug - Solder Cup Terminal

P.N.	Cable Group	Plt.	Ins.	Imp.	Crimp Tool
N1551A1-NT3G-50	N/A	Nickel	Teflon	50	N/A

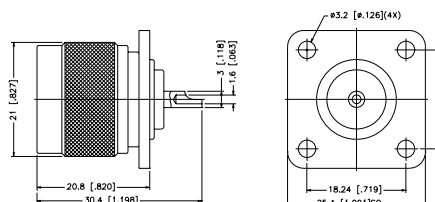

Panel Receptacle Jack - Solder Cup terminal

P.N.	Cable Group	Plt.	Ins.	Imp.	Crimp Tool
N6551A1-NT3G-50	N/A	Nickel	Teflon	50	N/A
N6551A1-017-NT3G-50	N/A	Nickel	Teflon	50	N/A
Captive Center Contact					
N6551A1-015-NT3G-50	N/A	Nickel	Teflon	50	N/A
Flush Rear					

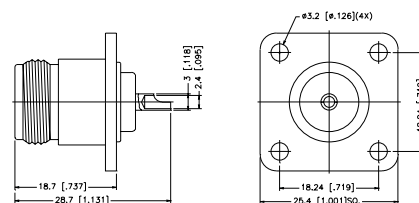

Panel Mount/Solder Receptacles

Panel Receptacle Jack - Solder Cup Terminal - Round Flange

P.N.	Cable Group	Plt.	Ins.	Imp.	Crimp Tool
N6551A1-013-NT3G-50	N/A	Nickel	Teflon	50	N/A

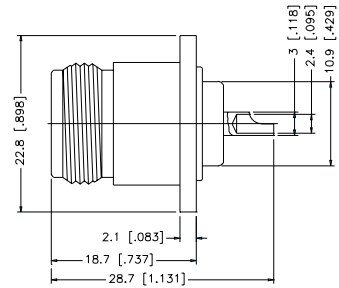

Panel Receptacle Plug - Slot Terminal

P.N.	Cable Group	Plt.	Ins.	Imp.	Crimp Tool
N1551C1-NT3G-0.3-50 Slot width: 0.3 mm, 0.5 mm, 0.7 mm, 0.9 mm	N/A	Nickel	Teflon	50	N/A
N1551M1-001-NT3G-50 Flat Tab	N/A	Nickel	Teflon	50	N/A

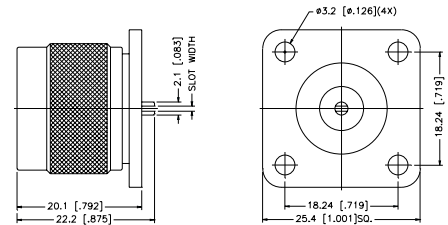

Panel Receptacle Jack - Slot Terminal

P.N.	Cable Group	Plt.	Ins.	Imp.	Crimp Tool
N6551C1-NT3G-0.3-50 Slot width: 0.3 mm, 0.5 mm, 0.7 mm, 0.9 mm	N/A	Nickel	Teflon	50	N/A
N6551E3-001-NT3G-50 2-Hole Flange Blunt Post	N/A	Nickel	Teflon	50	N/A
N6551C1-002-NT3G-50 .5 Flange Slotted Post	N/A	Nickel	Teflon	50	N/A
N6551C1-003-NT3G-50 .118 Diameter Contact Slotted Post	N/A	Nickel	Teflon	50	N/A
N6551C2-001-NT3G-50 .690 Flange Slotted Post	N/A	Nickel	Teflon	50	N/A

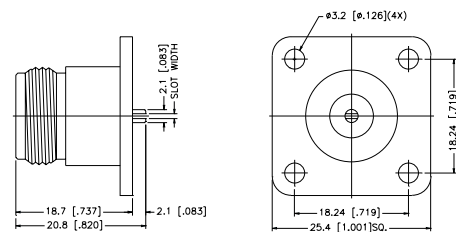

Panel Receptacle Jack - Extended Teflon

P.N.	Cable Group	Plt.	Ins.	Imp.	Crimp Tool
N6551A1-004-NT3G	N/A	Nickel	Teflon	50	N/A

Remark: Contact Amphenol for various lengths availability

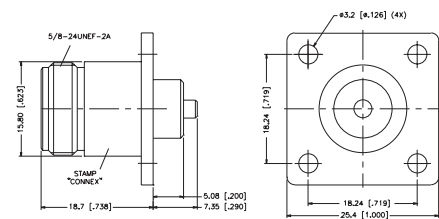

Panel Mount/Solder Receptacles

Panel Receptacle Jack - Extended Body

P.N.	Cable Group	Plt.	Ins.	Imp.	Crimp Tool
N6551A1-012-NT3G-50 Blunt Post	N/A	Nickel	Teflon	50	N/A
N6551A1-019-NT3G-50 Extended Teflon	N/A	Nickel	Teflon	50	N/A



N6551A1-012-NT3G-50

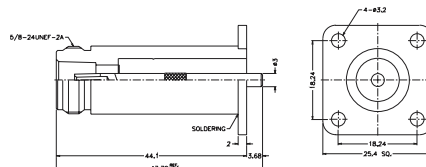

N6551A1-019-NT3G-50

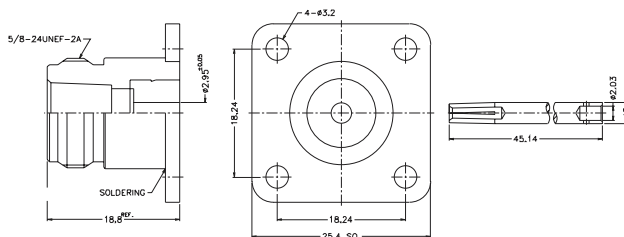

Panel Receptacle Jack - Extended body - Post Contact

P.N.	Cable Group	Plt.	Ins.	Imp.	Crimp Tool
N6551E1-020-NT3G-50	N/A	Nickel	Teflon	50	N/A

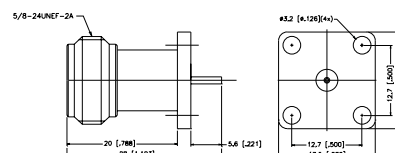

Panel receptacle Jack - Tab Post

P.N.	Cable Group	Plt.	Ins.	Imp.	Crimp Tool
N6551M1-001-NT3G-50	N/A	Nickel	Teflon	50	N/A

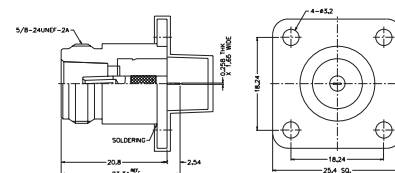

Printed Circuit Board Connectors

Straight P.C. Board Receptacle - Four Legs

P.N.	Cable Group	Plt.	Ins.	Imp.	Crimp Tool
N645100-003-T/NT3G-50 PCB Legs, Bright Tin	N/A	Nickel	Teflon	50	N/A

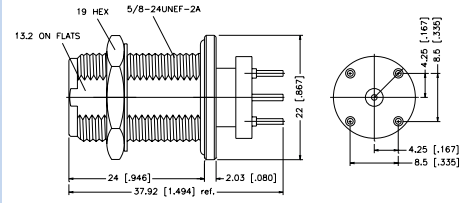

Push Fit Receptacle

P.N.	Cable Group	Plt.	Ins.	Imp.	Crimp Tool
N6051A1-001-NT3G-50	N/A	Nickel	Teflon	50	N/A

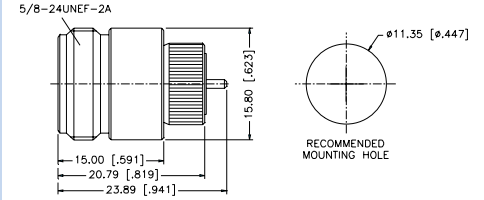

Right Angle P.C. Board Receptacle

P.N.	Cable Group	Plt.	Ins.	Imp.	Crimp Tool
N625200-001-TT30G-50	N/A	Tin Lead	Teflon	50	N/A

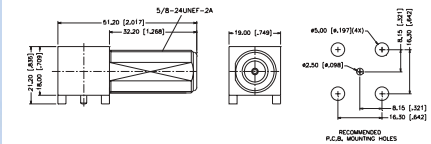

In-Series Adapters

Plug-to-Plug Adapter

P.N.	Cable Group	Plt.	Ins.	Imp.	Crimp Tool
N2071A1-NT3G-50	N/A	Nickel	Teflon	50	N/A
NM-RNM-NT3G-50 N Plug Reverse Polarized to N Jack	N/A	Nickel	Teflon	50	N/A
NF-RNF-NT3G-50 N Jack Reverse Polarized to N Plug	N/A	Nickel	Teflon	50	N/A

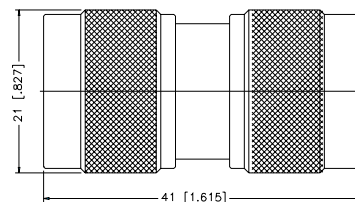

Jack-to-Jack Adapter

P.N.	Cable Group	Plt.	Ins.	Imp.	Crimp Tool
N7071A1-NT3G-50	N/A	Nickel	Teflon	50	N/A

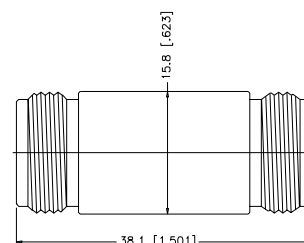

Jack-to-Jack Bulkhead Adapter

P.N.	Cable Group	Plt.	Ins.	Imp.	Crimp Tool
N7471A1-NT3G-50	N/A	Nickel	Teflon	50	N/A

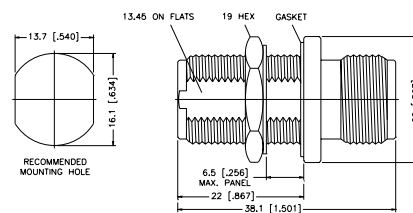

In-Series Tee Adapters

Tee Adapter - Jack-to-Plug-to-Jack

P.N.	Cable Group	Plt.	Ins.	Imp.	Crimp Tool
N9073A1-NT3G-50	N/A	Nickel	Teflon	50	N/A

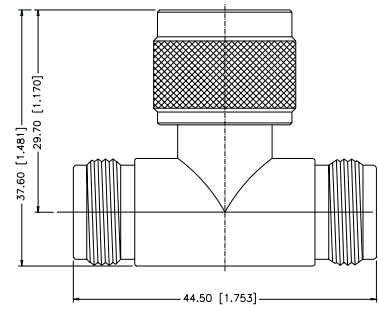

Tee Adapter - Jack-to-Jack-to-Jack

P.N.	Cable Group	Plt.	Ins.	Imp.	Crimp Tool
N8073A1-NT3G-50	N/A	Nickel	Teflon	50	N/A

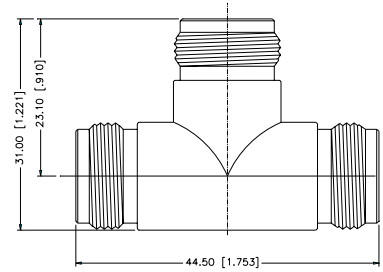

Tee Adapter - Plug-to-Jack-to-Jack

P.N.	Cable Group	Plt.	Ins.	Imp.	Crimp Tool
N9073A1-001-NT3G-50	N/A	Nickel	Teflon	50	N/A

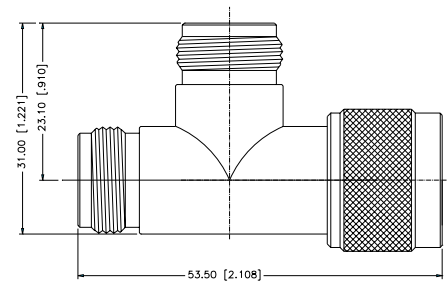

In-Series Angle Adapters

Angle Adapter - Plug-to-Jack

P.N.	Cable Group	Plt.	Ins.	Imp.	Crimp Tool
N5072A1-NT3G-50	N/A	Nickel	Teflon	50	N/A
N5072A2-NT3G-50	N/A	Nickel	Teflon	50	N/A
High Performance					

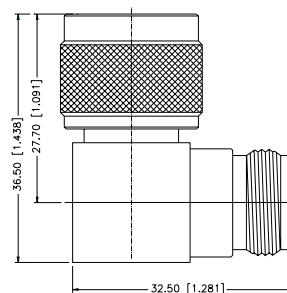

Angle Adapter - Plug-to-Plug

P.N.	Cable Group	Plt.	Ins.	Imp.	Crimp Tool
N2072A1-NT3G-50	N/A	Nickel	Teflon	50	N/A

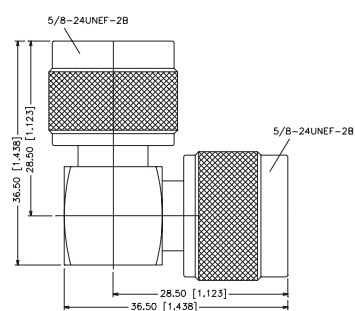

Terminators

Terminator Plug

P.N.	Cable Group	Plt.	Ins.	Imp.	Crimp Tool
N1004A1-NT3G-50R-1W	N/A	Nickel	Teflon	50	N/A
N1004A2-NT3G-50R-0.01-1W	N/A	Nickel	Teflon	50	N/A
High Frequency					

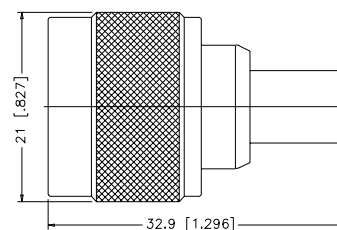

Terminators

Terminator Jack

P.N.	Cable Group	Plt.	Ins.	Imp.	Crimp Tool
N6004A1-NT3G-50R-0.05-1W	N/A	Nickel	Teflon	50	N/A

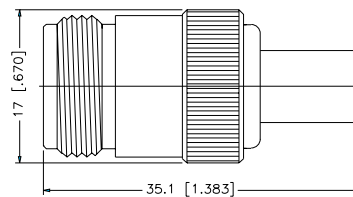

Accessories

Male Cap & Chain

P.N.	Cable Group	Plt.	Ins.	Imp.	Crimp Tool
U1005A1-N	N/A	Nickel	N/A	N/A	N/A

Remark: Chain length 100 [3.94]

