



IDEAL POWER
IDEAL POWER SOLUTIONS

SPECIFICATION FOR APPROVAL

Ideal Power

CUSTOMER: _____

DESCRIPTION: I.T.E POWER SUPPLY REV: (A1)

MODEL NO: HK-AJ-050A300-CP PART NO: HKSC-110369
ROHS Compliance

DESIGNED NO: 110369-0317 DATE: JUN.17th.2011

CUSTOMER APPROVED SIGNATURES			VENDOR APPROVED SIGNATURES		
					

MODEL NO. :	HK-AJ-050A300-CP	PAGE NO. :	1 OF 12
PART NO. :	HKSC-110369	ISSUED DATE:	2011.06.17
DESCRIPTION :	I.T.E POWER SUPPLY	REV:	(A1)

CONTENTS

1. INTRODUCTION
2. INPUT REQUIREMENTS
3. OUTPUT REQUIREMENTS
4. EFFICIENCY
5. LINE REGULATION
6. HOLD UP TIME
7. TURN ON TIME
8. TEMPERATURE COEFFICIENT
9. DIELECTRIC STRENGTH (Hi-Pot) TEST
10. INSULATION RESISTANCE
11. PROTECTION
12. ENVIRONMENTAL CONDITIONS
13. EMI/ EMC
14. RELIABILITY AND QUALITY CONTROL
15. SAFETY
16. OVERALL DRAWING
17. USE SPECIFICATION
18. PACKING
19. MARKING

MODEL NO. :	HK-AJ-050A300-CP	PAGE NO. :	2 OF 12
PART NO. :	HKSC-110369	ISSUED DATE:	2011.06.17
DESCRIPTION :	I.T.E POWER SUPPLY	REV:	(A1)

1.0 INTRODUCTION

This document specifies a switching power supply with a output of +5V, and electronic process. The switching power supply will provide power for technology equipments including electrical business equipment. The adaptor meets the requirement of lead free and RoHS.

2.0 INPUT REQUIREMENTS

2.1 Input Voltage Range: 100(-10%)VAC to 240(+10%)VAC

2.2 Input Frequency Range: 47 Hz to 63 Hz

2.3 Input Power Consumption at no-load : 0.3W Max

2.4 Input In-rush Current: 50A Max

2.5 Input Current: 0.8A Max

3.0 OUTPUT REQUIREMENTS

3.1 Output Voltage: +5V

3.2 Output Regulation: 4.75-5.25V

3.3 Output Load Range: 3.0A

3.4 Output Ripple & Noise: 200mV Max @20MHz bandwidth with
10UF/50V capacitance and 104/50V ceramic capacitor.

4.0 EFFICIENCY: $\geq 76.41\%$ @ average of 25/50/75/100% loads & 115/230VAC input

5.0 LINE REGULATION: 2% maximum

6.0 HOLD UP TIME: 10ms Min at 110VAC full load.

7.0 TURN ON TIME: 2S Max at 110VAC full load.

MODEL NO. :	HK-AJ-050A300-CP	PAGE NO. :	3 OF 12
PART NO. :	HKSC-110369	ISSUED DATE:	2011.06.17
DESCRIPTION :	I.T.E POWER SUPPLY	REV:	(A1)

8.0 TEMPERATURE COEFFICIENT: 0.05%/°C

9.0 DIELECTRIC STRENGTH (Hi-Pot) TEST

9.1 Finished product withstands AC 3.0KV, for 2 second, 4mA Max primary to secondary.

9.2 Finished product withstands AC 3.0KV, for 2 second, 4mA Max primary to case.

10.0 INSULATION RESISTANCE

Primary to secondary: 50M OHM to 500VDC.

11.0 PROTECTION

11.1 Input Protection

The switching power supply has a 2 Amps inner current fuse to protect itself.

11.2 Output Protection

11.2.1 Output Current:

Overload conditions shall decrease the output voltage Removal of an output overload shall provide automatic recovery for the output voltage.

11.2.2 Short Circuit Protection: Auto Recovery.

MODEL NO. :	HK-AJ-050A300-CP	PAGE NO. :	5 OF 12
PART NO. :	HKSC-110369	ISSUED DATE:	2011.06.17
DESCRIPTION :	I.T.E POWER SUPPLY	REV:	(A1)

16. OVERALL DRAWING

UNIT: mm

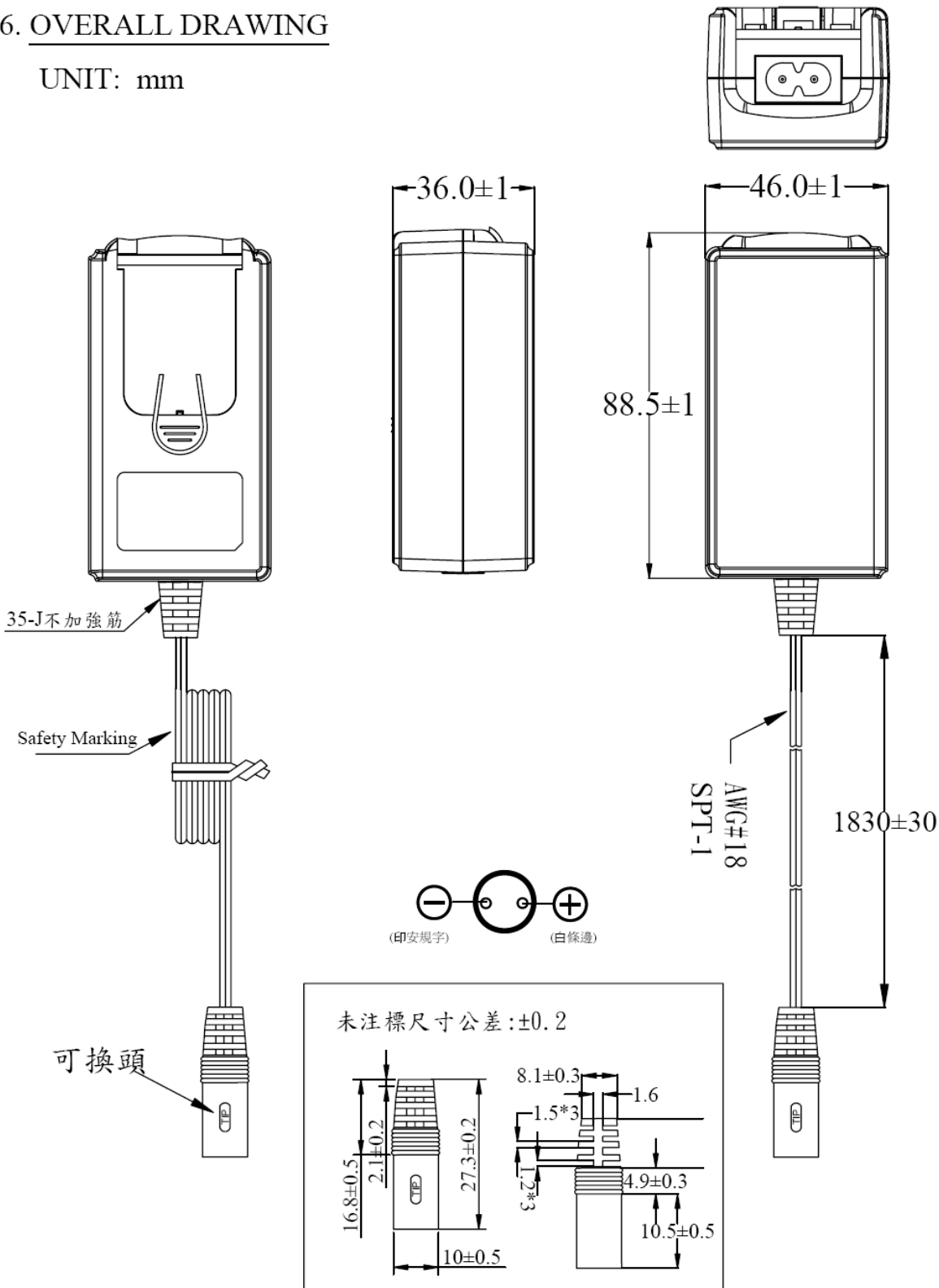

MODEL NO. :	HK-AJ-050A300-CP	PAGE NO. :	6 OF 12
PART NO. :	HKSC-110369	ISSUED DATE:	2011.06.17
DESCRIPTION :	I.T.E POWER SUPPLY	REV:	(A1)

UNIT: mm

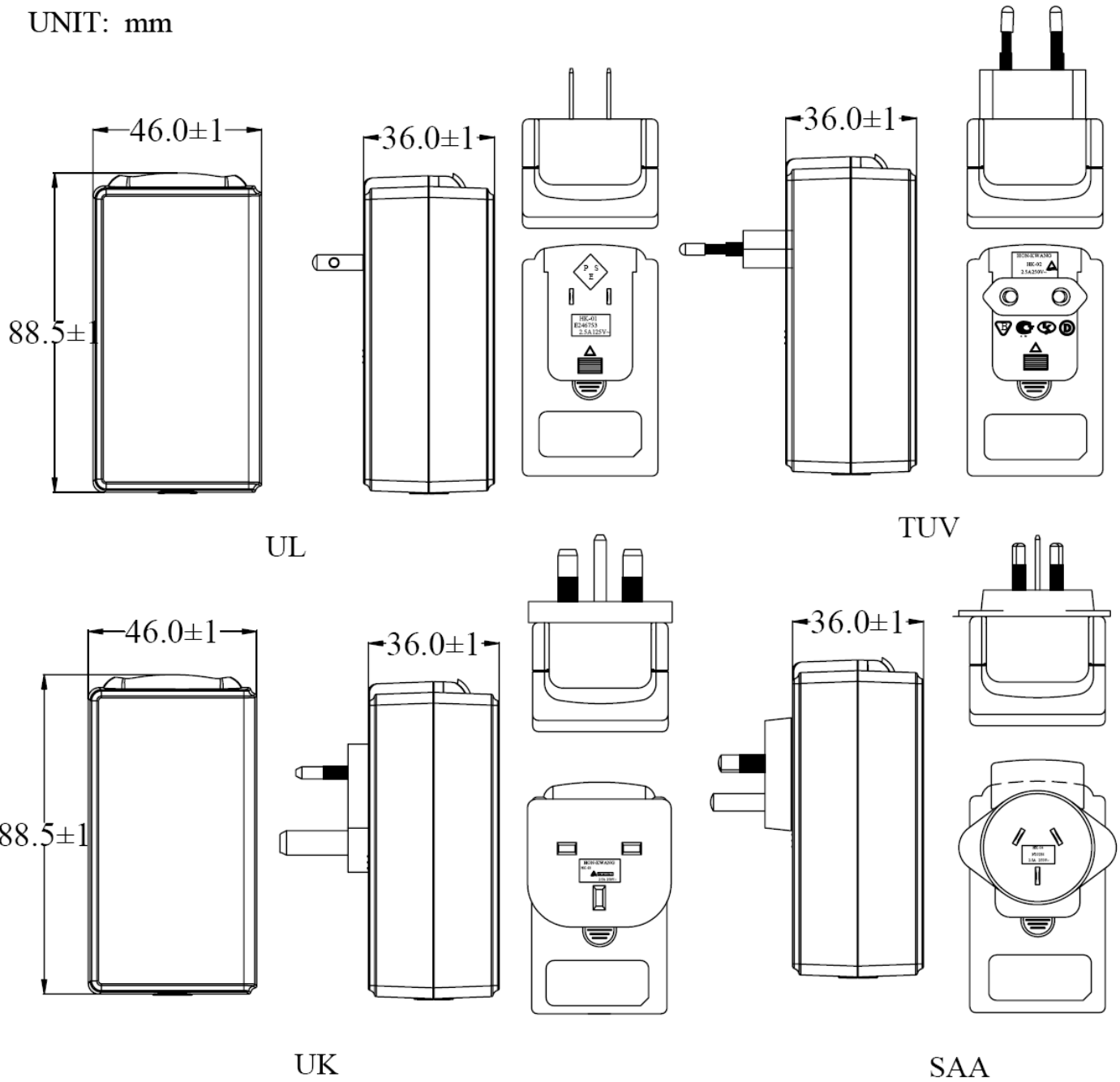

MODEL NO. :	HK-AJ-050A300-CP	PAGE NO. :	7 OF 12
PART NO. :	HKSC-110369	ISSUED DATE:	2011.06.17
DESCRIPTION :	I.T.E POWER SUPPLY	REV:	(A1)

UNIT: mm

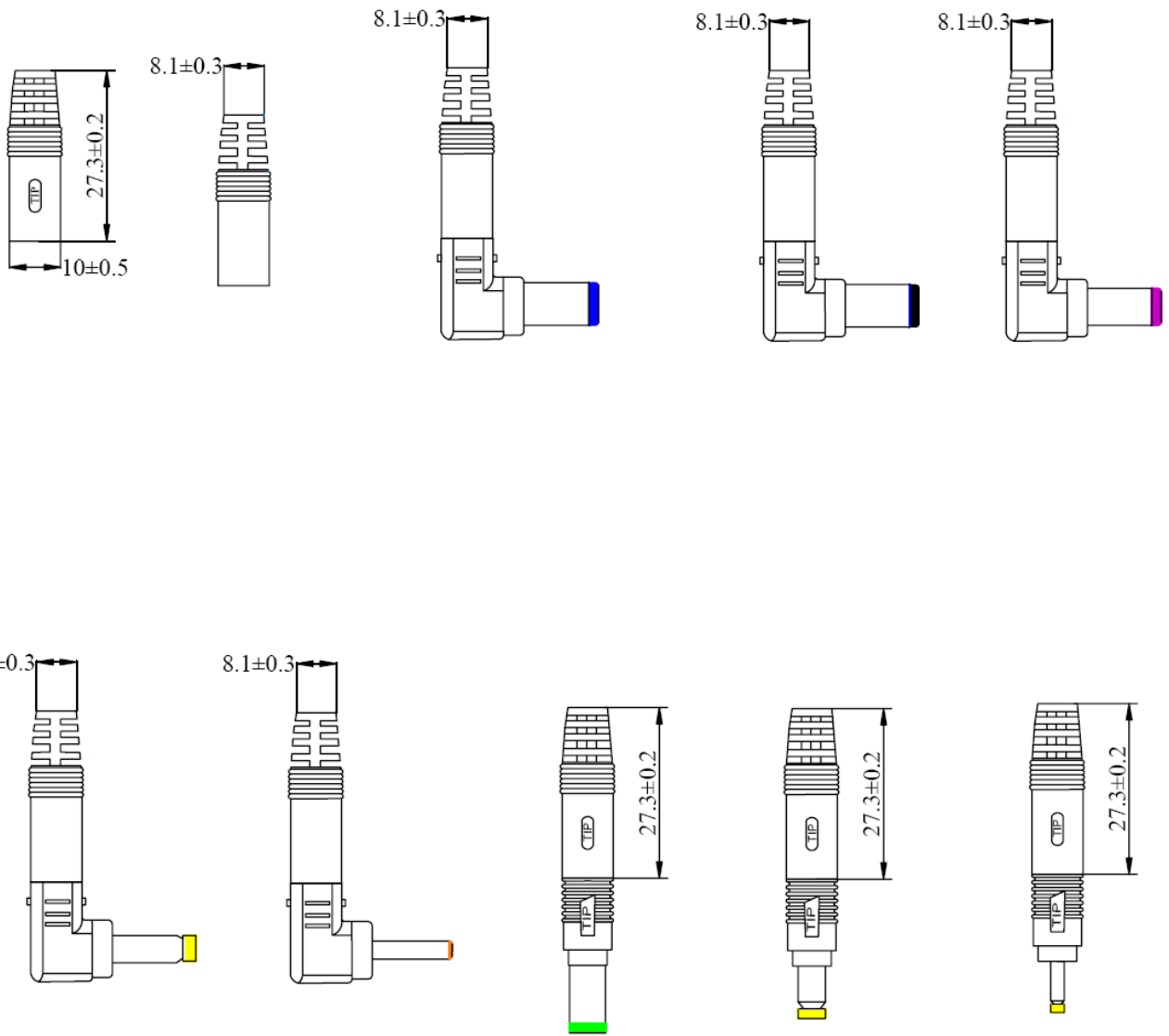

MODEL NO. :	HK-AJ-050A300-CP	PAGE NO. :	8 OF 12
PART NO. :	HKSC-110369	ISSUED DATE:	2011.06.17
DESCRIPTION :	I.T.E POWER SUPPLY	REV:	(A1)

17. USE SPECIFICATION

WARNING!

Please don't insert article alone at the wall.

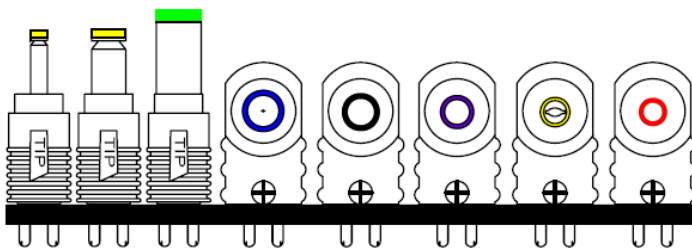
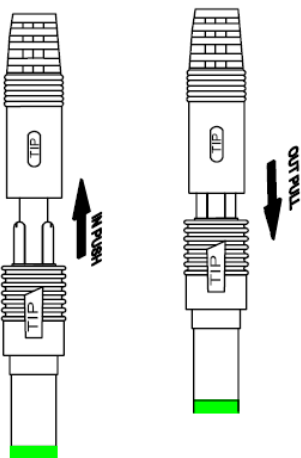
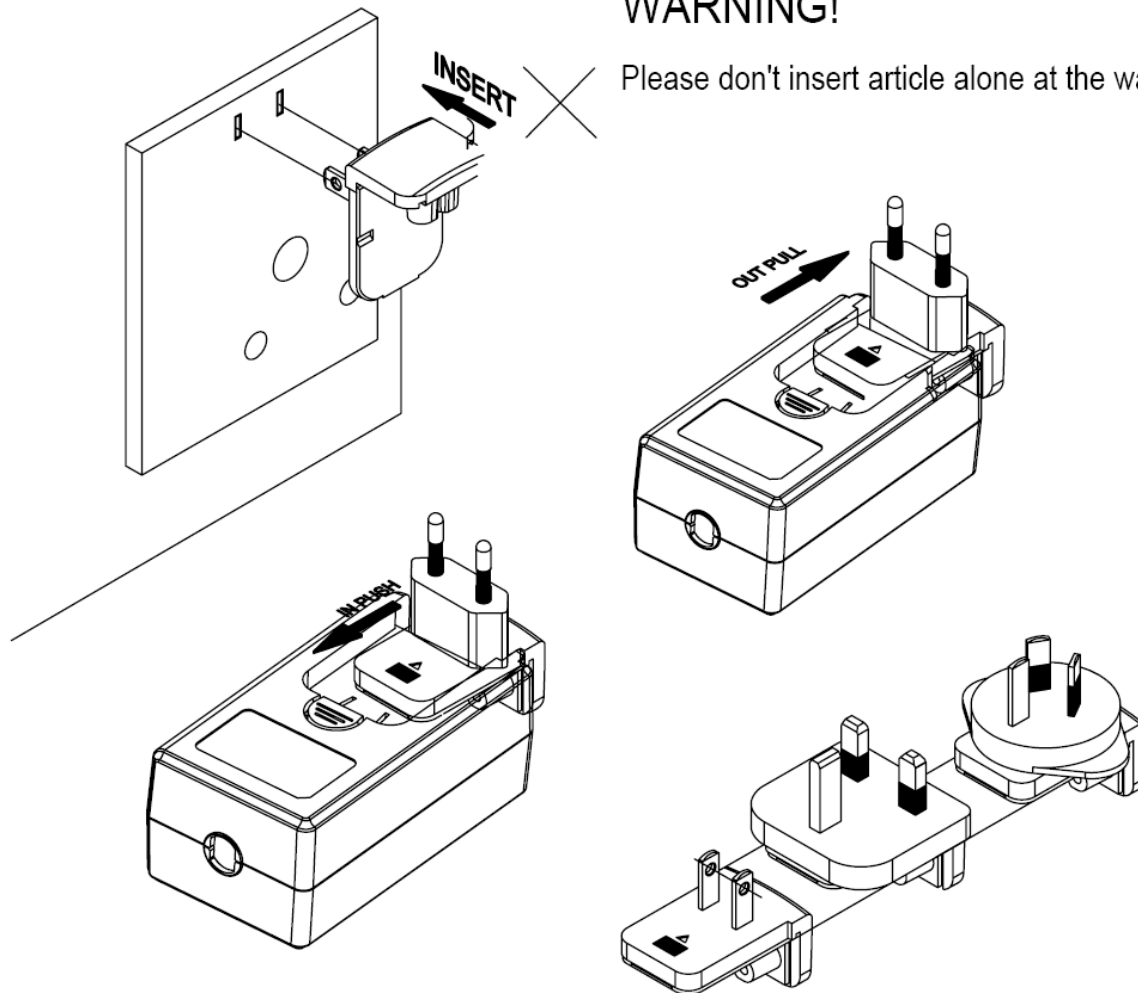

MODEL NO. :	HK-AJ-050A300-CP	PAGE NO. :	9 OF 12
PART NO. :	HKSC-110369	ISSUED DATE:	2011.06.17
DESCRIPTION :	I.T.E POWER SUPPLY	REV:	(A1)

18. PACKING

18.1 Inner Box

UNIT: mm



PE BAG

Length :

Width :

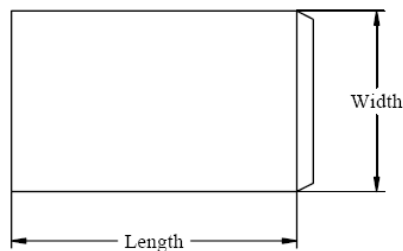

BUBBLE BAG

Length:

Width:

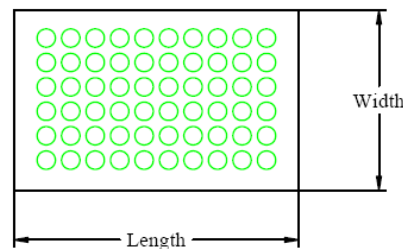

BOX(Normal BOX Corrugated BOX)

Length: 145

Width: 75

Height: 65

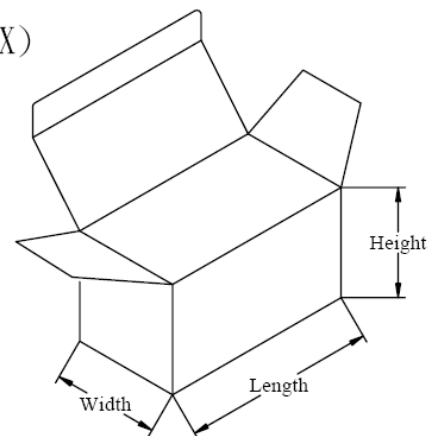

NOTICE:

Its probably different from the white box of the sample and the figure dimension. The white box is used to pack during product.

注意: 樣品使用的小白盒尺寸可能與此圖面尺寸不同, 此圖面尺寸是用于生產時的包裝.

MODEL NO. :	HK-AJ-050A300-CP	PAGE NO. :	10 OF 12
PART NO. :	HKSC-110369	ISSUED DATE:	2011.06.17
DESCRIPTION :	I.T.E POWER SUPPLY	REV:	(A1)

18. PACKING

18.2 Carton

UNIT: mm

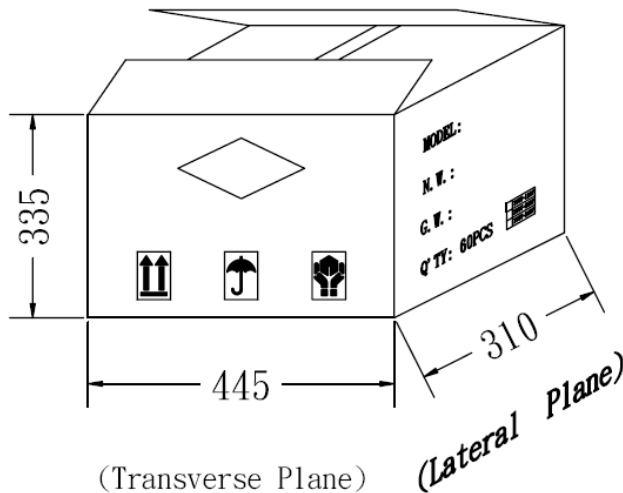
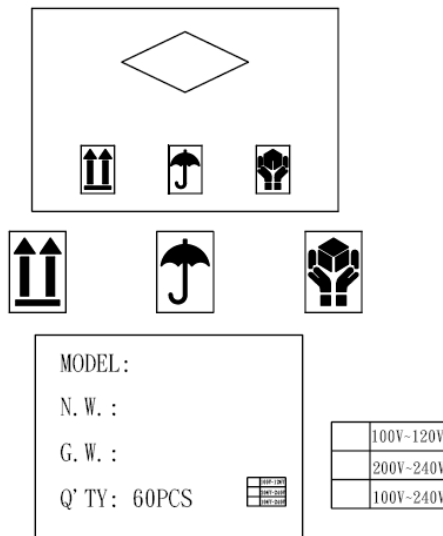

MODEL NO. :	HK-AJ-050A300-CP	PAGE NO. :	11 OF 12
PART NO. :	HKSC-110369	ISSUED DATE:	2011.06.17
DESCRIPTION :	I.T.E POWER SUPPLY	REV:	(A1)

19. MARKING

0.2mm 變色龍 NAME-PLATE:SILVER CHARACTERS BLACK BACKGROUND.

UNIT: mm

