

AC-AC Plugtop Adaptors

Features

- 230Vac Mains Input Voltage only
- Mains Vac to low Vac converter/adaptor
- Attractive black plastic case
- UK and Euro plug parts from stock
- 1.8Meter O/P lead
- 2.1mm or multipack O/P plugs
- 1 Year Warranty

More Information

Our AC-AC UK & Euro Plugtop Adaptors are high quality and high reliability units which operate in Europe and countries running 230VAC 50Hz mains voltage. As standard they come in a black plastic case but this along with many other features can be modified for a custom order for very specific individual customer requirements. These units are manufactured in China and comply with EN60950-1, CE, EMC and safety requirements.

Please Note: Many AC-AC adaptors are not very energy efficient and can not meet Level IV and V energy efficiency requirements as set out in European law, however there are many exemptions. Please make sure you bear this in mind when you design new products or are looking to source our AC-AC Adaptors.



Product Selection Chart with electrical specifications

UK Plug Range										
Part Number	Voltage (On load)	Voltage (Off Load)	Current	Insulation (@500VDC)	Hi-Pot Test (IP-OP)	Magnetising Current	Thermal Fuse	O/P Connector	Case Size.	Weight (Kg)
S2252ST	9Vac	10.8Vac	300mA	100Mohm.	4200VAC	40mA	130°C	6-pack	EI-35	0.23
S2072ST	9Vac	10.7Vac	600mA	100Mohm.	3750VAC	50mA	130°C	6-pack	EI-41	0.35
S2074ST	9Vac	10.39Vac	1000mA	100Mohm.	3750VAC	40mA	130°C	6-pack	EI-48	0.46
T2525ST	9Vac	10.39Vac	1000mA	100Mohm.	3750VAC	40mA	130°C	2.1x5.5x12	EI-48	0.46
T3004ST	12Vac	14.5Vac	500mA	100Mohm	3750VAC	60mA	130°C	2.1x5.5x12	EI-41	0.36
S2270ST	12Vac	14.5Vac	500mA	100Mohm	4200VAC	60mA	130°C	6-pack	EI-41	0.36
S2232ST	12Vac	14.2Vac	1000mA	100Mohm	3750VAC	50mA	130°C	6-pack	EI-48	0.48
T2524ST	12Vac	14.2Vac	1000mA	100Mohm	3750VAC	50mA	130°C	2.1x5.5x12	EI-48	0.46
S2234ST	15Vac	18.6Vac	500mA	100Mohm	3750VAC	50mA	130°C	6-pack	EI-41	0.36
S2073ST	18Vac	20.1Vac	500mA	100Mohm	4200VAC	50mA	130°C	6-pack	EI-48	0.49
T2840ST	25Vac	27Vac	500mA	100Mohm	3750VAC	60mA	130°C	6-pack	EI-48	0.50

Euro Plug Range										
Part Number	Voltage (On load)	Voltage (Off Load)	Current	Insulation (@500VDC)	Hi-Pot Test	Magnetising Current	Thermal Fuse	O/P Connector	Case Size.	Weight (Kg)
S2254ST	12Vac	14.5Vac	500mA	100Mohm	4200VAC	50mA	130°C	6-pack	EI-41	0.33
T3485ST	24Vac	27Vac	500mA	100Mohm	4200VAC	60mA	130°C	6-pack	EI-48	0.48

Other voltages, current ratings and mains wall-pins (USA, AZ etc.) also available on request.



Stontronics Ltd

Chancerygate Business Centre, Cradock Road, Reading, Berkshire, RG2 0AH.

Tel: +44 (0) 118 931 1199 • Fax: +44 (0) 118 931 1145 • Email: info@stontronics.co.uk • Web: www.stontronics.co.uk

Please Note: Image shown is representative of entire range. Individual PSU image &/or drawings or data sheets available on request.

Stontronics Ltd accepts no responsibility for typographical errors in the production of this leaflet. Product specifications are subject to change without notice.

AC-AC Plugtop Adaptors

O/P Plug Configurations

- 6-Pack Set Details:

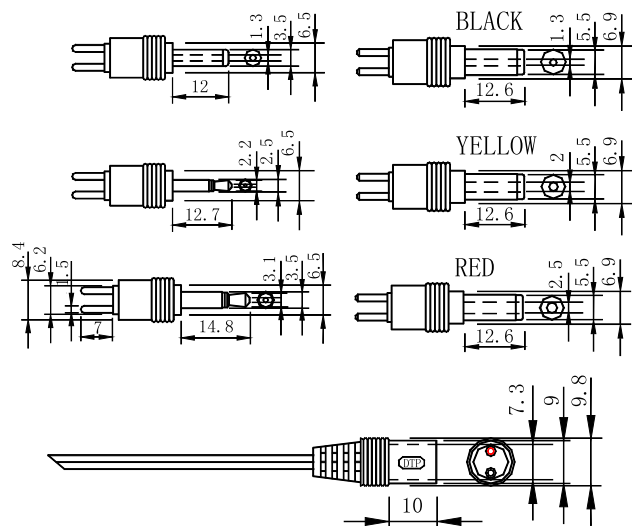

- 2.1 x 5.5 x 12mm Details:

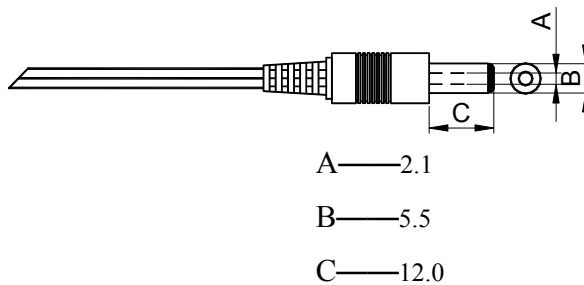

Case Drawings

- EI-35-BS Details:

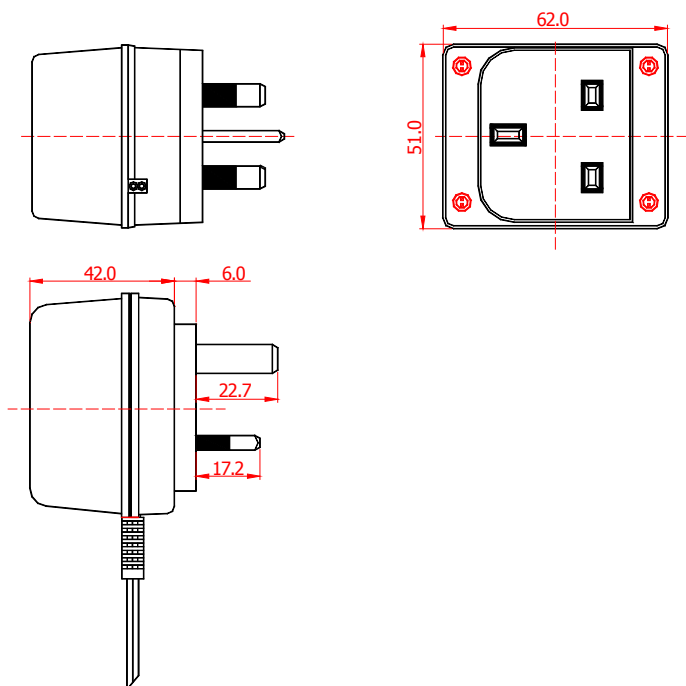

- EI-41-BS Details:

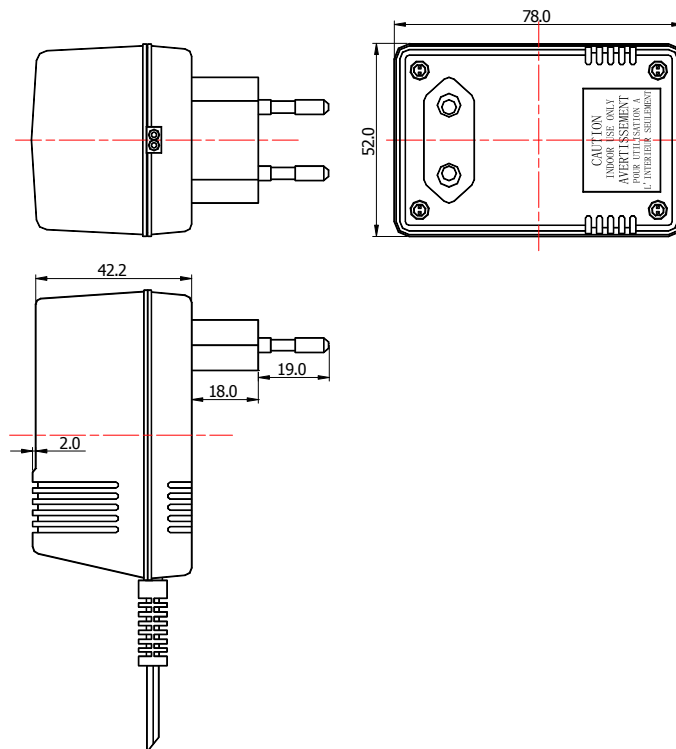

Stontronics Ltd

Chancerygate Business Centre, Cradock Road, Reading, Berkshire, RG2 0AH.

Tel: +44 (0) 118 931 1199 • Fax: +44 (0) 118 931 1145 • Email: info@stontronics.co.uk • Web: www.stontronics.co.uk

Please Note: Image shown is representative of entire range. Individual PSU image &/or drawings or data sheets available on request.

Stontronics Ltd accepts no responsibility for typographical errors in the production of this leaflet. Product specifications are subject to change without notice.

AC-AC Plugtop Adaptors

Case Drawings

• EI-48-BS Details:

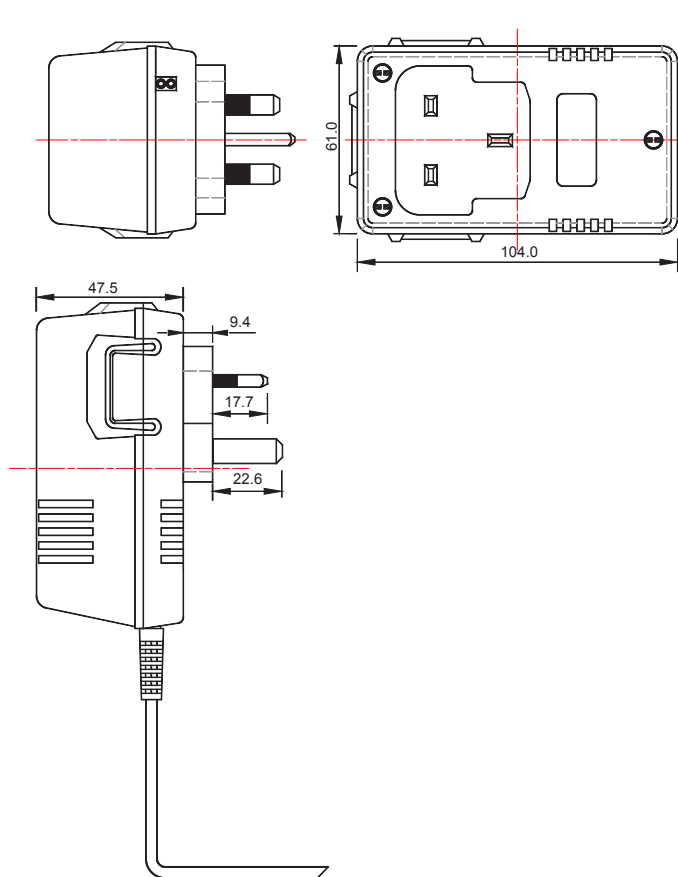

• EI-41-EU Details:

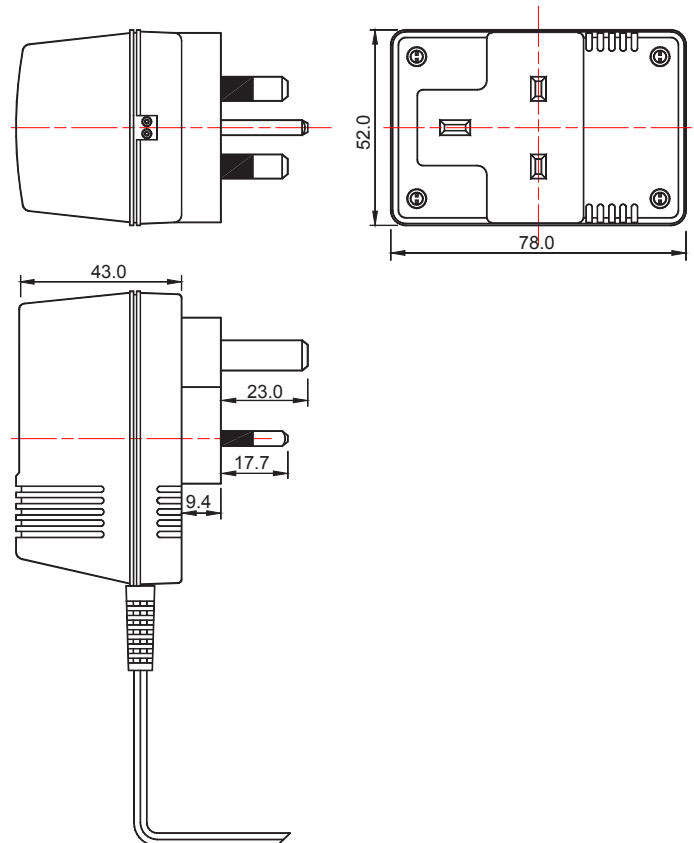

• EI-48-EU Details:

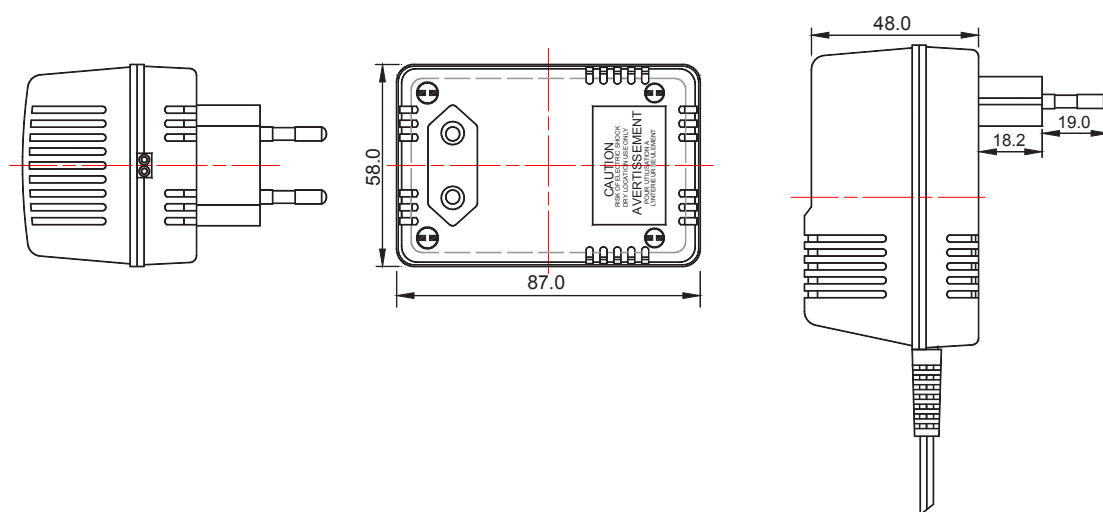

Stontronics Ltd

Chancerygate Business Centre, Cradock Road, Reading, Berkshire, RG2 0AH.

Tel: +44 (0) 118 931 1199 • Fax: +44 (0) 118 931 1145 • Email: info@stontronics.co.uk • Web: www.stontronics.co.uk

Please Note: Image shown is representative of entire range. Individual PSU image &/or drawings or data sheets available on request.

Stontronics Ltd accepts no responsibility for typographical errors in the production of this leaflet. Product specifications are subject to change without notice.