



5011639801-4A01

# ELC-485APTR

## Instruction sheet

### RS-485 Interface Adpater

#### ⚠ WARNING

- ELC-485APTR is an OPEN-TYPE. Please place the module in an enclosure away from airborne dust or high humidity and prevent electric shock or sudden collision on ELC-485APTR. Also, it is equipped with protective methods such as some special tool or key to open the enclosure, so as to avoid the hazard to users or any damage to the module.
- I/O terminal screws should be tightened to between 1.95 kg-cm (1.7 lb-in). Use copper conductor only, 60 oC / 75oC.
- Warning – Do not disconnect while circuit is live unless area is known to be non-hazardous.
- Power, input and output (I/O) wiring must be in accordance with Class 1, Div. 2 wiring methods - Article 501-10(B)(1) of the National Electrical Code.
- Suitable for use in class 1, division 2, groups A, B, C, D or Non-Hazardous locations only.
- Warning – Explosion hazard - Substitution of components may impair suitability for Class 1, Division 2.
- Warning – Explosion hazard - Do not disconnect equipment unless power has been switched off or the area is known to be Non-Hazardous.

1

#### INTRODUCTION

ELC-485APTR is mainly designed to connect Eaton product by RS-485 interface. It is equipped with surge absorber and limited current protection to ensure safe connection of different devices. Also, a switch enabled built-in terminator ( $120\Omega$ ).

#### Environmental Specification:

Operation	0°C ~55°C (Temperature), 50~95%(Humidity), pollutant degree 2
Storage	-25°C ~70°C (Temperature), 5~95% ( Humidity )
UL Class 1 Div.2	Ambient Temperature 55°C , Operating temperature code: T5
Vibration/Shock resistance	International Standard: IEC61131-2, IEC 68-2-6 ( TEST Fc ) / IEC61131-2 & IEC 68-2-27 (TEST Ea)

#### Product profile:

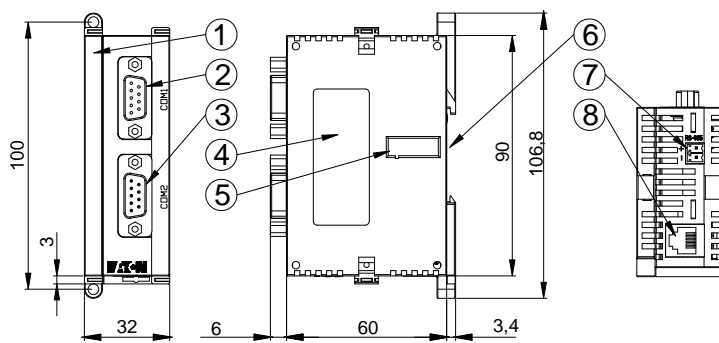

Units: mm

Fig.1: Profile and Dimensions

1. Mounting plate
2. COM 1 (DB9 female)
3. COM 2 (DB9 male)
4. Nameplate
5. ON/OFF of termination resistor (factory setting: OFF)
6. DIN rail (35mm)
7. RS-485 port
8. RJ12 port

2

#### ELC-485APTR Connection with Eaton Products

Connection of ELC-485APTR and AC Motor Drive (please see AC motor drive user manual for detail information)

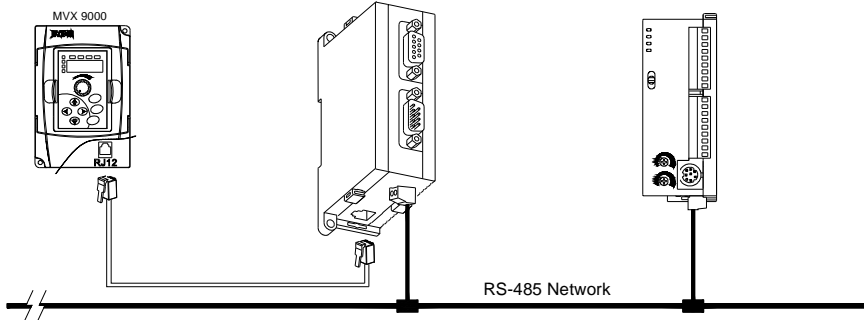

Fig.2: ELC controller connection with MVX9000

**Compact Installation reference:**

See Fig. 3a in lower left, when ELC-485APTR is separated from mounting plate, it can be used as the last extension module with its RS-485 port connecting to ELC controller's (see Fig. 3b for illustration). This connection is feasible for ELC controller to connect AC Motor Drive within 5 meters.

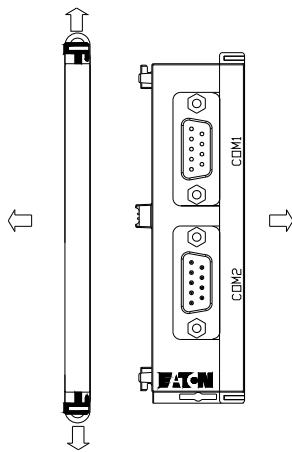

Fig. 3a

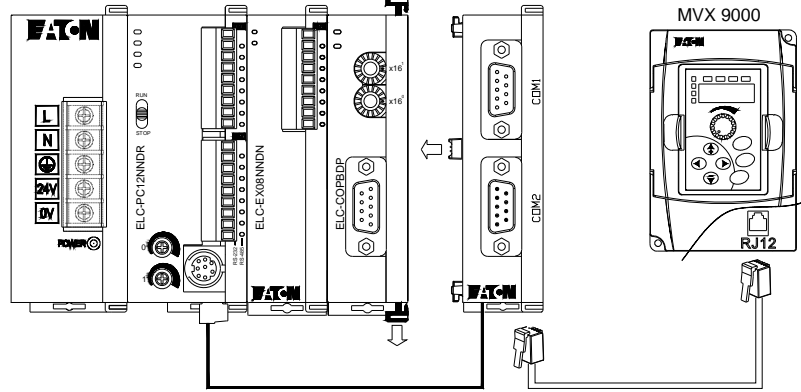
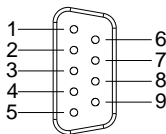

Fig. 3b

**PIN Explanation of COM1, COM2, and RJ12**

COM1-DB9 female



PIN	Definition
1	RS485-
2	RS485+
3	RS485+
4	RS485-
5-9	NC

RJ12 of AC Motor Drive side

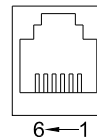

PIN	Definition
1	+15V
2	GND
3	SG-
4	SG+
5, 6	Reserved

COM2-DB9 male

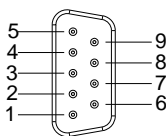

PIN	Definition
3, 6	RS485-
8	RS485+
5, 9	GND
1, 2, 4, 7	NC

RJ12 of ELC-485APTR side

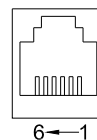

PIN	Definition
3	RS-485+
4	RS-485-
5	GND
1, 2, 6	NC

**3 ELC-485APTR Termination Resistor Application**

In all RS-485 installations, the cable must be correctly terminated with two sets of resistors, one set at each end of the network (4,000 feet maximum total cable length). This applies even if you are only using one slave node connected to one master device. The terminating resistors prevent reflection problems that can interfere with data transmission. The resistance value of the terminating resistors should match the characteristic impedance of the cable. A typical value is 120 ohms. The terminating resistors must be placed at the two farthest ends of the RS-485 network, regardless of where the master device is. In some cases master device RS-485 ports have built in or optional terminating resistors. Beware of your network (whether it has one node or 32 nodes) having only two sets of terminating resistors.

ELC-485APTR's Termination Resistor Switch is located inside of the adapter's extension port.

Switch ON the termination resistor for ELC-485APTR on the both ends only and switch OFF (factory setting) for the modules between both ends when modules are connecting in parallel.

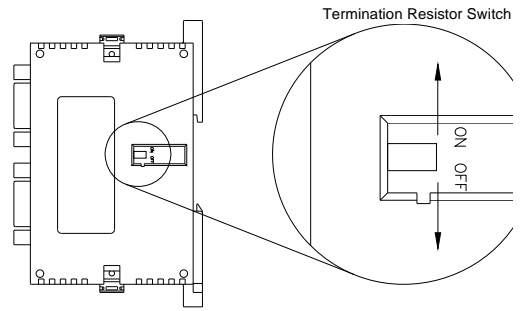

Fig. 4