

Double-Pole Rocker Switch WR Series

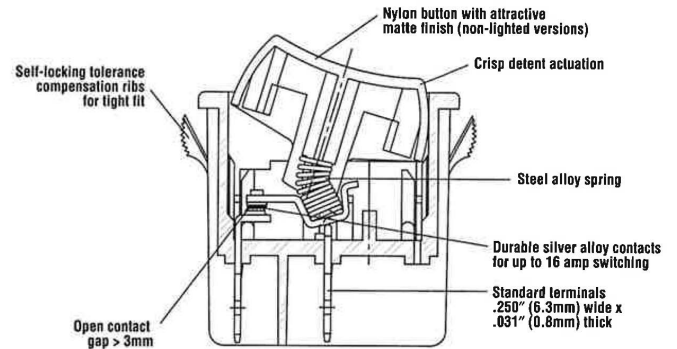

Features

- Rugged design for 2-pole high current designs
- Lighted and non-lighted
- Maintained action and momentary
- Single pole and double pole

Electrical Ratings				
Switch Series	EN61058 Rating	UL1054 Rating	Electrical Life at Rated Load	
			According to VDE (Min. Operations)	According to UL (Min. Operations)
WR	16(4)A, 250V, 10(2)A 250VAC, T125 5E4	16A, 125/250VAC; 1/4HP@125/250 VAC, 3/4HP @250VAC	10,000	6,000

Electrical Specifications		Material Specifications	
Ratings:	16A, 125/250VAC; 1/4HP@125/250VAC; 3/4HP@250 (UL) 16A, 125/250VAC; 1/4HP@125/250VAC (CSA) 16(4)A, 250V~, 10(2) 250VAC, T125 5E4 (VDE)	Actuator (non-lighted): (lighted):	Nylon 66 94V-2 Polycarbonate
Dielectric Strength:	1000VAC for 1 minute	Base:	Nylon 66 94V-2
Insulation Resistance:	100M ohms min at 500VDC	Spring:	Steel Wire
Initial Contact Resistance:	0.020 ohms max	Contacts:	Silver Alloy
Temperature Range:	-20°C to + 65°C	Movable Arm:	Silver-Plated Copper Alloy
		Terminals:	Tin-Plated Copper Alloy

RoHS Compliant
 UL File No: E23301



Specifications subject to change without notice.



Double-Pole Rocker Switch

WR Series

Dimensions inches (mm)

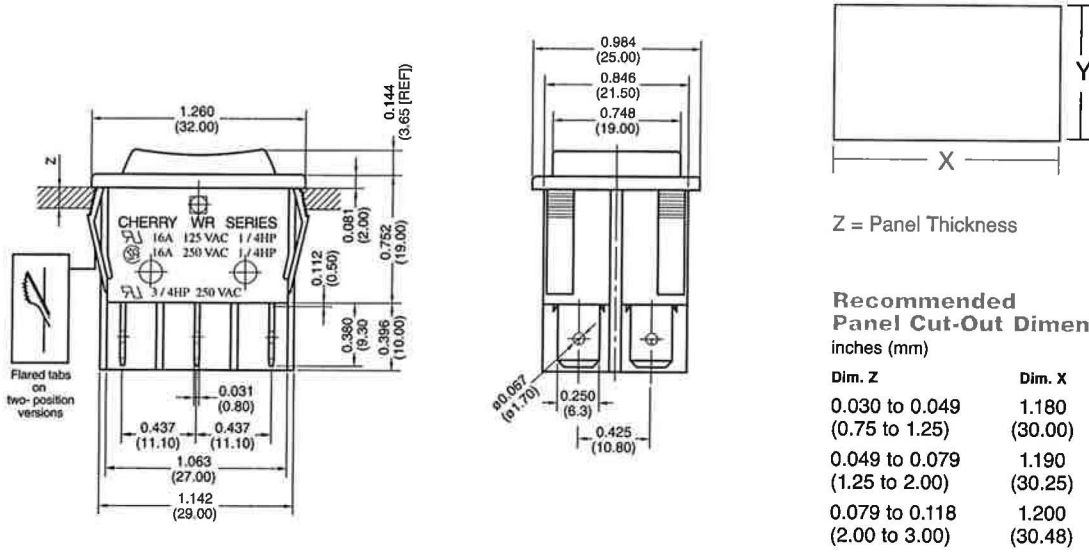

Recommended Panel Cut-Out Dimensions

inches (mm)

Dim. Z	Dim. X	Dim. Y
0.030 to 0.049 (0.75 to 1.25)	1.180 (30.00)	0.867 (22.02)
0.049 to 0.079 (1.25 to 2.00)	1.190 (30.25)	0.867 (22.02)
0.079 to 0.118 (2.00 to 3.00)	1.200 (30.48)	0.867 (22.02)

Ordering Information

Code	Contact Rating
G	16A, 125/250VAC; 1/4 HP (UL & CSA); 3/4 HP 250VAC (UL) 16(8)A, 250V~, T125/55 1E4 (VDE) 10(2)A, 250V~, T125/55 50E3(VDE)

Code	Terminal type inches (mm)
A	0.189" (4.8) QC
F	0.250" (6.3) QC

Code	Switch Function
2	On - Off
3	On - On
5	(On) - Off
6	(On) - On

Code	Actuator Type
2	Curve
5	Flat Actuator

Code	Actuator Marking
B	Blank
C	⏏
D	⏏
E	O I
F	O -

Code	Housing Color
B	Black
W	White
Y	Grey

Code	Actuator Color
A	Amber
B	Black
G	Green
R	Red
W	White
Y	Grey

Code	Lighted
N	Non-Lighted
L	Lighted (Bulb 125VAC)
E	Lighted (Bulb 250VAC)
F	Lighted 5VDC Incandescent
G	Lighted 6VDC Incandescent
H	Lighted 12VDC Incandescent

Code	Splashproof
N	No Rocker Boot

Rocker boot sold separately P/N: 0015-0646

Examples of Common Part Numbers and Descriptions inches (mm)

Part Number	Circuitry	Switch Function	Terminal Type	Actuator/Housing Color	Legend Marking	Contact
WRG32F2FBBNN		On - Off	0.250 (6.3) Quick-Connect	Black/Black		Call, fax or visit our Website for more information. ZF Electronics Corporation 11200 88th Avenue Pleasant Prairie, WI 53158 Phone: 262.942.6500 Web: www.cherrycorp.com Email: cep_sales@zf.com Fax: 262.942.6566
WRG32F2BBRLN		On - Off/Lighted	0.250 (6.3) Quick-Connect	Red/Black		The manufacturer accepts no liability for errors or non-availability, and reserves the right to change specifications without prior notice. Technical data relates to product specifications only. Features may differ from those described. Only drawings combined with product specifications shall be deemed binding.

© 2007 ZF Electronics Corporation

Last Updated: 11/16/11

