



Cigarette Lighter Torch.

A removable flashlight in the car cigarette lighter gives car manufacturers the possibility to extend brand awareness to the customer by focusing on increased comfort and multi useable standard accessories.

Battery challenge.

Weight, reliability, thickness and optimum diameter is one of the most important features for removable flashlight as well as long shelf life respectively steady availability in charged state with high stability against overcharging. The battery must supply high discharge currents to drive the LED for about 1h usage time.

Technical solution

The V18HRT cell out of the powerful85 family of Ni-MH button cells from VARTA Microbattery is specially designed for high discharge currents and extended temperature.

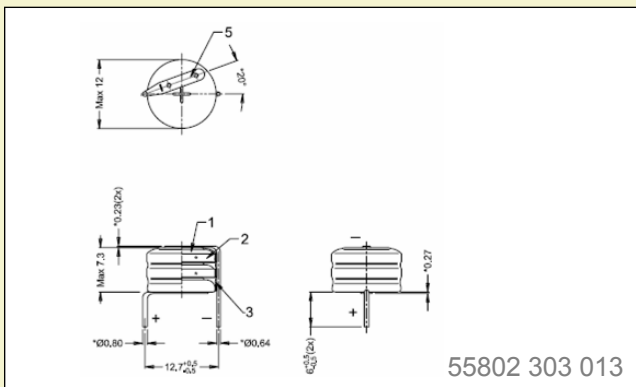

Characteristics	3/V18HRT Battery
Voltage level	3.6V (other voltages possible)
Capacity	19mAh
Overcharge capability	0.6mA for 5 years @ RT
Weight	3.0g
Discharge Temperature Range	-20 to +85° C
Dimension	Ø 12mm x 7.3mm

Cigarette Lighter Battery

VARTA Microbattery's Ni-MH HRT batteries (Powerful85C family) offer rechargeable battery solutions with reliable power for supplying automotive light applications with an independent power source. Configurations: 3/V18HRT to 6/V18HRT

- wide temperature range from -20 to +85° C
- long lifetime – up to 10 years
- high reliability – by special sealing construction with new plastic materials
- high current capability
- design flexibility on voltage level from 1.2V to 6.0V
- design flexibility on battery shape side-by-side or stacked
- simple charging system – continuous charging possible
- UL recognized cell
- environmentally friendly Ni-MH technology

Cigarette lighter torch

VARTA Microbattery GmbH
Daimlerstraße 1
73479 Ellwangen/Germany
Tel +49 79 61 921-280

www.varta-microbattery.com